

FAYETTEVILLE PUBLIC WORKS COMMISSION

**SPECIFICATIONS AND BID DOCUMENTS FOR
ONE 67KV Delta to 13.09Y/7.56KV Wye with LTC**

24/32/40MVA POWER TRANSFORMERS

FOR THE CUMBERLAND ROAD SUBSTATION

ISSUED FOR BIDS April 13, 2022

**FAYETTEVILLE PUBLIC WORKS COMMISSION
SPECIFICATIONS AND BID DOCUMENTS FOR
67KV Delta to 13.09Y/7.56KV Wye with LTC
24/32/40MVA POWER TRANSFORMERS**

TABLE OF CONTENTS

TITLE	PAGE NO.
NOTICE TO PROSPECTIVE BIDDERS	N1
DEFINITIONS	D 1-2
INSTRUCTIONS TO BIDDERS	IB 1-6
GENERAL CONDITIONS	GC 1-5
MATERIALMAN'S PROPOSAL	P 1-8
NORTH CAROLINA BID BOND	P 9
SALE OF GOODS AGREEMENT	C 1-6
 TECHNICAL SPECIFICATIONS	
1.0 Scope	S1
2.0 General Conditions	S1
3.0 Special Conditions	S2
4.0 Standards	S3
5.0 Drawings	S3
6.0 Shipping of Transformer	S5
7.0 Manufacturer's Field Representative	S6
8.0 Transformer	S6
9.0 Additional Features	S 21
10.0 Tests	S 23
11.0 Guarantees	S 26
12.0 Transformer Bid Evaluation	S 27
13.0 Transformer Accessories	S 28
14.0 Transformer Cabinet and Wiring	S 29
15.0 Transformer Tank and Oil Preservation	S 30
16.0 Transformer Winding and Core Construction	S 30
17.0 Transformer Paper Insulation for Conductor Insulation	S 31
18.0 Final Test	S 32

APPENDICES

- 1 - Typical current Transformer Arrangement for Power Transformers
- 2 - Power Transformer Neutral Support Bracket Detail
- 3 - Minimum clearance for Power Transformers
- 4 - Vicinity Map
- 5- DGA Specification

FAYETTEVILLE PUBLIC WORKS COMMISSION

NOTICE TO PROSPECTIVE BIDDERS

Pursuant to N.C.G.S 143-129, Sealed Proposals will be received by the Fayetteville Public Works ("PWC") Commission, Fayetteville, North Carolina until 2:00 p.m., local time, Thursday, May 5, 2022, at the Fayetteville Public Works Commission Administration Building, 955 Old Wilmington Rd., Fayetteville, North Carolina 28301, Outside by the Entrance Doors, at which time they will be publicly opened and read for the purchase of:

**One 67KV Delta to 13.09Y/7.56KV Wye with LTC
24/32/40MVA POWER TRANSFORMERS**

Specifications and Proposal forms may be obtained from the PWC Procurement Department at, <https://www.faypwc.com/purchasing> and in the Fayetteville Public works Commission's Procurement Department, 1st Floor, PWC Administration Building, 955 Old Wilmington Rd, Fayetteville, NC between the hours of 8:00 a. m. and 5:00 p. m., Monday through Friday.

Each Proposal shall be accompanied by cash, cashier's check, or certified check drawn on a bank insured by the Federal Deposit Insurance Corporation or Savings Association Insurance Fund in an amount not less than five percent (5%) of the total bid as a guarantee that a Contract, if awarded, will be entered into. In lieu thereof, a Bid Bond which conforms to the provisions of G.S. 143-129 as amended by Chapter 1104 of Public Laws of 1951 may be submitted by the Bidder.

Proposals must be enclosed in a sealed envelope and marked "PROPOSAL FOR **One 67KV Delta to 13.09Y/7.56KV LTC POWER TRANSFORMERS**, NOT TO BE OPENED UNTIL 2:00 P.M., LOCAL TIME, May 5 , 2022". Bidders are to mail or deliver their Proposals as follows: Fayetteville Public Works Commission, 955 Old Wilmington Rd., Attention: Carla Wint, Procurement Advisor, Fayetteville, NC 28301.

All late Bids shall be returned unopened to the sender. Regardless of the bidder's chosen means of delivery, a bidder assumes responsibility for deliver to the advertised location by the advertised deadline. If the delivery service cannot deliver the bid to the proper location by the deadline, the bid must be rejected as untimely, and shall be returned unopened to the sender.

PWC reserves the right to reject any or all bids and to waive all formalities concerning bid, and award bid to the lowest responsive, responsible Bidder or Bidders taking into consideration quality, performance, and the time specified in the proposals for the performance of the Contract.

FAYETTEVILLE PUBLIC WORKS COMMISSION
FAYETTEVILLE, NORTH CAROLINA

By Trent Ensley
Procurement Manager

Date: April 13, 2022

DEFINITIONS

Whenever in these “Instructions to Bidders”, “Materialman’s Proposal”, “Technical Specifications”, “Agreement”, “Bond”, etc., the following terms or pronouns in place of them are used, the intent and meaning shall be interpreted as follows:

Commission or Owner or PWC	Fayetteville Public Works Commission
General Manager	Elaina Ball or her authorized designee.
COO Electric Systems	Jonathan Rynne, PE or his authorized designee.
Substation Manager	Joel Valley or his authorized designee.
Procurement Manager	Trent Ensley, or his authorized designee.
Observer	An authorized representative of the Commission assigned to make any or all necessary observations of work performed and equipment and/or apparatus furnished by the Materialman.
Bidder or Materialman	Any individual, firm, or corporation submitting a Proposal for the work contemplated, acting directly or through a duly authorized representative.
Subcontractor	An individual, firm, or corporation who contracts with the Materialman to perform part of or, upon Commission approval, all of Materialman’s Contract.
Surety	The body, corporate or individual, approved by the Commission which is bound with and for the Materialman, who is primarily liable, and which engages to be responsible for its acceptable performance of the work for which it has contracted.
Proposal	The approved prepared form on which the Bidder is to submit or has submitted his Proposal for the work contemplated.
Bid Deposit	To all bids there shall be attached cash, cashier's check, or certified check of the Bidder upon a bank authorized to do business in North Carolina, or in lieu thereof, a Bid Bond.
Plans	All drawings or reproductions of drawings pertaining to the constructions under the Contract.
Technical Specifications	The directions, provisions, and requirements contained herein pertaining to the method and manner of performing the work or to the quantities and qualities of material to be furnished under the Contract.

Contract or Agreement	The Sales of Goods Agreement covering the furnishing of equipment and/or apparatus and the performance of the work. The Contract shall include the “Materialman’s Proposal”, “Plans”, “Technical Specifications”, “Acknowledgements” and any other Contract Documents.
Work	The performance of the project is covered by the Specifications or the furnishing of labor, machinery, equipment, tools, or any other article or thing being purchased by the Commission.
Emergency	A temporary, unforeseen occurrence or combination of circumstances which endangers life and property and calls for immediate action or remedy.

The subheadings in these Contract Documents are intended for convenience or reference only and shall not be considered as having any bearing on the interpretations thereof.

INSTRUCTIONS TO BIDDERS

1.0 Proposals

- 1.1 Only those Proposals made in accordance with these instructions will be considered.
- 1.2 Proposals must be made on the Contractor's Proposal provided herein and must not be altered, erased, or interlined in any manner. The Contractor shall fill in the Contractor's Proposal as detailed in the instructions. The Bidder may retain one (1) copy, but the original, fully executed, must be inserted in or attached to the Specifications and Bid Documents. In addition, one (1) copy of all executed forms and supporting information shall be submitted with original.
- 1.3 Proposals must be enclosed in a sealed envelope, addressed to the attention of Nikole Bohannon, Procurement Advisor. The outside of the envelope must be marked as required in the "Notice to Prospective Bidders" and the Bidder's name, bid opening date and time must shown thereon. All Proposals must be made on the blank forms provided in the Contractor's Proposal.
- 1.4 Proposals shall include a Form of Exceptions utilizing forms provided which shall itemize each and every exception from the Technical Specifications. The Form of Exceptions shall state the section, subsection, and paragraph designations from the part of the Specifications to which exception is taken and explain in detail the nature of the exception. A copy of this Form of Exceptions is included in the Contractor's Proposal section. Exceptions will not necessarily eliminate a Bidder from consideration, even if bids without exceptions are received from others. The treatment of exceptions will be based entirely on the overall best interests of PWC.
- 1.5 Invoice shall list the appropriate state sales tax as a separate item.
- 1.6 The prices as quoted herein:
 - a. Are firm unless otherwise stated.
 - b. Do include the cost of delivery to the site at the Bidder's Risk.
- 1.7 Modifications to bids must be by removal of the Bidder's original bid and the submittal of a completely revised bid package in full compliance with the Plans, Technical Specifications, and Bid Documents. This is required prior to the time of opening bids. No oral or telephonic Proposals will be accepted.
- 1.8 The Materialman represents and acknowledges that it has reviewed, familiarized itself, and has a complete necessary understanding for any Work at Site of Project. Materialman further represents and acknowledges that it has examined the Technical Specifications for the work and the Contract Documents relative thereto, read all special provisions furnished prior to the opening of the bids, and satisfied himself relative to the work to be performed.

- 1.9 The materials will conform to the Technical Specifications sections attached hereto and made a part hereof.
- 1.10 Should the Bidder find discrepancies in or omissions from the Drawings or Contract Documents or should he be in doubt as to their meaning, he shall at once notify Trent Ensley with PWC, who will send written instructions to all Bidders. Neither PWC nor the Engineer will be responsible for any oral instructions. If Plans and Specifications are found to disagree after Contract is awarded, the PWC shall be the judge as to what was intended. The Successful Bidder is hereby made responsible for the furnishing of the necessary labor, tools and equipment reasonably inferred or evidently necessary for the proper execution and completion of the work; for any additional work involved in the correction of apparent errors or inconsistencies, and in executing the true intent and meaning of the Drawings and Specifications as interpreted by PWC and all such labor and equipment shall be provided at the Contractor's expense, and under no condition will any such labor and equipment be allowed as an extra.
- 1.11 After opening, bids may only be withdrawn in accordance with N.C.G.S. 143-129.1.

2.0 Payment

- 2.1 Payment by the Commission to the Successful Bidder shall be made in accordance with the milestone payment schedule as follows:
- Milestone Payment Schedule:
10% upon approval of submitted drawings
30% upon receipt of copper and core steel at the factory
35% upon shipment of transformer to owner
20% after delivery to site, setting on pad, dressed, and tested
5% retainage up to 60 days after delivery
- Milestone Percentages, less retainage, to build transformer and after it is demonstrated that the equipment meets the Specifications.
- 2.2 In accordance with N.C.G.S. 143-134.1, the Commission will retain five percent (5%) of the amount of each monthly periodic payment. The Commission, after fifty percent (50%) of the work has been completed, will consider waiving further retainage on the project upon the following conditions: (1) written consent of surety is received; (2) satisfactory progress is being made on the Project; and (3) prior to fifty percent (50%) completion, any nonconforming work identified in writing by the Engineer has been corrected by the Contractor and accepted by the Engineer. If retainage is discontinued or reduced, the Commission reserves the right to reinstate retainage up to the five percent (5%) level if the Contractor performs unsatisfactorily. Furthermore, the Commission reserves the right to continue to retain payment, even in the event the Contractor's work is satisfactory, in order to ensure a total of two and one-half percent (2.5%) retainage over the life of the project. The Commission reserves the right to withhold additional payments for unsatisfactory job progress, defective construction not remedied, disputed work, or third-party claims filed against the Commission or reasonable evidence that a third-party claim will be filed.

- 2.3 The address for submittal of all invoices is Fayetteville Public Works Commission, 955 Old Wilmington Road, Fayetteville, North Carolina 28301, Attention: Joel Valley.

3.0 Bid Security

- 3.1 Each Proposal shall be accompanied by a cash deposit, cashier's check, or certified check drawn on a bank or trust company insured by the Federal Deposit Insurance Corporation or Savings Association Insurance Fund, or a Bid Bond in an amount not less than five percent (5%) of the Proposal. Said deposit will be retained by PWC as liquidated damages in the event of failure of the successful Bidder to execute the Contract within ten (10) days after the award.
- 3.2 Bid Bond shall be conditioned that the Surety will, upon demand, forthwith make payment to the Obligee upon said Bond if the Bidder fails to execute the Contract in accordance with the Bid Bond, and that upon failure to forthwith make payment, the Surety shall pay to the Obligee an amount equal to double the amount of said Bond.
- 3.3 Only one (1) Bid Bond is required, the amount of which shall be based on the total amount of the bid. The value for the Bid Bond shall be based on the Bid Schedule of maximum total amount.

4.0 Bulletins and Addenda

Any bulletins or addenda to the Specifications issued during the time of bidding are to be considered covered in the Proposal, and in executing a Contract, they will become a part thereof. Receipt of addenda shall be acknowledged by the Bidder.

5.0 Delivery of Equipment

The base prices quoted for each power transformer shall include delivery of the transformer FOB Point of Delivery, Fayetteville, North Carolina.

Transformer site location for the transformer will be our Cumberland Road Substation. The address of site is 2336 Carbine Street, Fayetteville, NC 28306. All delivery sites will be located within the service territory of PWC in and surrounding Fayetteville, North Carolina. PWC will provide reasonable roadworthy access to each final destination.

Delivery of all items of equipment shall be made to permit unloading between the hours of 9:00 a.m. and 3:00 p.m., Monday through Thursday, holidays excluded. The Materialman shall give forty-eight (48) hours' notice of all deliveries.

Quoted prices for materials and equipment shall include shipment to the substation site. Each power transformer will be delivered by the Materialman complete with crane services unloading and rigging transformer onto a permanent concrete pad. Once the transformer is completely unloaded by the Materialman, manufacturer and its labor or contractor, at the appropriate time, will assemble any parts removed for shipment. The Materialman will furnish the services of a field service engineer for the supervision of this reassembly as specified under the manufacturer's field service requirements.

Coordinated shipment shall be made to reduce storage by PWC and to facilitate the accumulation of component parts. **Partial shipments at scattered times will not be acceptable.** In the event that delays occur, the Materialman shall be responsible for all shipping demurrage, unless such delays are caused solely by the Commission.

Receipt of "Approval Drawings" by the Materialman constitutes an authorization for manufacture only, predicated upon the Drawings and corrections found thereon. Tentative release for shipment is to be granted by either PWC or PWC's Engineer, based upon the following:

1. Twenty-one (21) consecutive days prior notification of tests so that PWC may have a representative present to witness the tests.
2. Furnishing of the requested number of copies of the Final Drawings as called for in the Contract Documents.
3. Coordination of manufacturing and delivery with Commission's construction schedule as may be noted in the Contract Documents.
4. Thirty (30) days' notification of tentative shipping schedule and forty-eight (48) hours' notification prior to all deliveries.

6.0 Award of Contract

- 6.1 The Award of Contract will be made to the lowest, responsive, responsible Bidder as soon as practicable, taking into consideration quality, performance, and the time specified in the proposals for the performance of the contract. Commission reserves the right to reject any and all bids.
- 6.2 The Commission reserves the right to waive minor irregularities or minor errors in any Proposal if it appears to the Commission that such irregularities or errors were made through inadvertence.
- 6.3 In evaluating bids for award of the contract, the Commission will consider pricing submitted by the bidder and the following factors:

1. Equipment delivery date.
2. Adherence to the Plans and Technical Specifications.
3. Suitability of materials and equipment.
4. Firm prices.
5. Additional extended warranty.
6. Standardization of equipment.
7. Long-range economy.
8. History of prior delivery performance.
9. No-Load and Load Loss Evaluation.
10. Accessibility of service facilities and personnel.
11. History of prior equipment and service personnel performance.

6.4 The required deliveries are shown in the Proposal. Strict adherence to the quoted delivery schedule is required. Special attention should be given to the stipulations for delivery outlined in the General Conditions section of this document. Furthermore, the Materialman shall match its scheduled deliveries to the schedule preferred by the Commission if noted in the Proposal section.

6.5 In the event that the Bidder proposes any change or deviation from the Engineer's Plans and Specifications, such Proposal changes or deviations must be submitted at the time bids are opened. The Commission reserves the right to reject any such proposed changes or deviations. All exceptions must be stated on the Form of Exceptions. Failure to submit a Form of Exceptions will establish strict adherence to the Plans and Specifications.

6.6 The Commission reserves the right to accept any schedule, combination of schedules, or any portion of a schedule.

7.0 Performance Bond/Payment Bond

A Performance Bond/Payment Bond is not required for this project.

8.0 Examination of Conditions

Prior to submission of the Proposal, the Bidder shall make and shall be deemed to have made a careful examination of the Plans and Technical Specifications on file with the Commission and with the Engineer and all other matters that may affect the cost and the time of completion of the work.

9.0 Bids to be Retained

No bid may be withdrawn after the scheduled closing time for the receipt of bids for a period of sixty (60) days pending the execution of a Contract by the Successful Bidder.

11.0 Materialman's Proposal Form

Those bids not received on Fayetteville PWC Materialman's Proposal Form contained herein will be considered non-responsive. **All forms and sections shall be filled out completely.** Any omissions may cause the entire Proposal to be rejected.

12.0 Questions

Questions regarding this bid must be submitted in writing to the attention of Carla Wint, Procurement Advisor at carla.wint@faypwc.com no later than **5:00 p.m., April 22, 2022.**

Bidders are **prohibited** by contacting any PWC official, employee, or agent other than as listed above. Failure to comply with this provision will result in disqualification of the Bidder.

13.0 Additional Purchase Clause

The Commission reserves the right to purchase additional units as specified herein within a one year period of contract award, upon the agreement of both parties.

GENERAL CONDITIONS

1.0 Drawings and Contract Documents

The Drawings and Contract Documents are complementary, one to the other. That which is shown on the Drawings or called for in the Contract Documents shall be as binding as if it were both called for and shown. The intention of the Drawings and Contract Documents is to include all labor, materials, transportation, equipment, and all other things necessary to do a complete job. In case of discrepancy or disagreement in the Contract Documents, the order of precedence shall be: Contract, Technical Specifications, Large-Scale Detail Drawings, Small-Scale Drawings.

2.0 Clarifications and Detail Drawings

In cases where the nature of the work requires clarification by the Engineer, such clarification shall be furnished by the Engineer with reasonable promptness by means of written instructions or Detail Drawings or both. Clarifications and Drawings shall be consistent with the intent of Contract Documents and shall become a part thereof.

3.0 Copies of Drawings and Contract Documents

PWC will furnish free of charge to the Materialman two (2) copies of Plans and Contract Documents, whichever is applicable.

4.0 Ownership of Drawings and Contract Documents

All Drawings and Contract Documents are instruments of service and remain the property of the Engineer whose name appears thereon. The use of these instruments on work other than this Contract without permission is prohibited. All copies of Drawings and Contract Documents other than Contract copies shall be returned to the Engineer upon request after completion of the work.

5.0 Royalties, Licenses, and Patents

It is the intention of the Commission that the work covered in the Contract Documents will not constitute in any way an infringement on any patent whatsoever. The Materialman shall protect and save harmless the Commission against suit on account of alleged or actual infringement. The Materialman shall pay all royalties and/or license fees required on account of patented articles or processes, whether or not the patent rights are evidenced hereinafter.

6.0 Uncorrected Faulty Work

Should a correction of faulty or damaged work be considered inadvisable or inexpedient by the Commission or the Engineer, the Commission shall be reimbursed by the Materialman for the same by a deduction in the Contract price. This deduction shall be arrived at by a fair estimate of the probable cost of correction, approved by all parties.

7.0 Delays and Extension of Time

7.1 The time to be allowed for delivery shall be stated on the Materialman's Proposal bound with the Contract Documents. The Materialman, upon Notice of Award of Contract, shall prepare a construction schedule based on the allowed time and submit such schedule to the Engineer for approval.

7.2 If Materialman is delayed at any time in the progress of the work by any act of negligence by the Commission or by changes ordered in the work, the time of completion shall be extended for such reasonable time as the Commission may decide.

7.3 No extension of time for completion will be made for ordinary delays and accidents. Extensions may be granted for delays ordered by the Engineer if the request has been made in writing within forty-eight (48) hours after the order to cease work has been given.

8.0 Guarantee

The Materialman shall guarantee their materials and workmanship against defect due to faulty materials or faulty workmanship or negligence for a period of five (5) years following final acceptance of the material and equipment. Materialman shall make good any defective materials or workmanship and any damage resulting therefrom without cost to the Commission.

9.0 PCB Dielectrics

All oil-filled materials and equipment shall be certified in writing and by permanently-affixed nameplates to have a non-detectable level of PCB dielectrics, i.e., less than 2 ppm, in compliance with Federal Register (44FR31514), May 31, 1979.

10.0 Assignments

The Materialman shall not assign any portion of this Contract nor Subcontract in its entirety except as fully explained in the Materialman's Proposal and accepted by the Commission. No funds or sums of money due or to become due the Materialman under this Contract may be assigned.

11.0 Change in Plans and/or Contract Documents

The Commission, or the Engineer on behalf of the Commission, may make changes to Plans and/or Specifications after award of the Contract or while construction is in progress. The compensation for such changes shall be agreed upon in writing between the Materialman and the Commission prior to commencement of work involving the change. No payment shall be made to the Materialman for correcting work not in compliance with the Specifications.

12.0 Reserved

13.0 Special Conditions

13.1 Defective Materials, Equipment, and Workmanship

13.1.1

All materials and equipment furnished hereunder shall be subject to the inspection, tests, and approval of the Commission and the Materialman shall furnish all information required concerning the nature or source of any materials and equipment and provide adequate facilities for testing and inspecting the materials and equipment at the plant of the Materialman.

13.1.2 Basic Right of Rejection

The materials and equipment furnished hereunder shall become the property of the Commission when delivered at the point to which shipment is to be made, provided, however, that the Commission may reject any such materials and equipment that do not comply with the Specifications and warranties of the Materialman and manufacturers. Recognition and subsequent rejection of any defective materials and equipment may occur either before or after incorporation of such materials and equipment into the facilities, provided such rejection is made within 60-days of date of energization of the materials and equipment. Upon any such rejection, the Materialman shall replace the rejected materials and equipment with materials and equipment complying with the Technical Specifications and warranties, F.O.B. truck at suitable destination. The Commission shall return the rejected materials F.O.B. truck at the same destination.

The Uniform Commercial Code UCC § 2-601 and 2-602 will be the guideline for the "Perfect Tender Rules" for such terms as "rejection, acceptance, and inspection".

In the event of the failure of the Materialman to so replace rejected materials and equipment, the Commission may make such replacement and the cost and expense thereof shall be paid by and recoverable from the Materialman.

13.1.3 The transformer to be provided herein shall include a full five (5) year warranty on the complete transformer together with all parts. This warranty shall extend for five (5) years from the date of delivery.

14.0 Equal Employment Opportunity

During the performance of this Contract, the Materialman agrees as follows:

1. The Materialman will not discriminate against any employee or applicant for employment because of race, color, religion, sex, national origin, political affiliation or belief, age, or physical handicap. The Materialman will take affirmative action to ensure that applicants are employed and that employees are treated during employment without regard to race, color, religion, sex, national origin, political affiliation or belief, age, or physical handicap. Such action shall include but not be limited to the following: employment, upgrading, demotion or transfer, recruitment or recruitment advertising, layoff or termination, rates of pay or other forms of compensation and selection for training, including apprenticeship. The Materialman agrees to post in conspicuous places available to employees and applicants for employment notices setting forth the provisions of the nondiscrimination clause.
2. The Materialman will, in all solicitations or advertisements for employees placed by or on behalf of the Materialman, state that all qualified applicants will receive consideration for employment without regard to race, color, religion, sex, national origin, political affiliation or belief, age, or physical handicap.
3. The Materialman will send to each labor union or representative of workers with which it has a collective bargaining agreement or other Contract or other understanding, a notice advising the labor union or workers' representative of the Materialman's commitments under the Equal Employment Opportunity Section of this Contract and shall post copies of the notice in conspicuous places available to employees and applicants for employment.
4. In the event of the Materialman's noncompliance with the nondiscrimination clauses of this Contract or with any of such rules, regulations, or orders, this Contract may be canceled, terminated, or suspended in whole or in part and the Materialman may be declared ineligible for further Commission contracts.
5. The Materialman will include the provisions of this section in every subcontract unless exempted by rules, regulations, or orders of PWC so that such provisions will be binding upon each Subcontractor.

15.0 Iran Divestment Act

As mandated by NCGS 147-86.59(a), Materialman hereby certifies that it is not listed on the Final Divestment List created by the North Carolina State Treasurer pursuant to NCGS 147-86.58. Consultant further certifies that in accordance with NCGS 147-86.59(b) that it shall not utilize any sub-consultant found on the State Treasurer's Final Divestment List. Consultant certifies that the signatory to this Contract is authorized by the Materialman to make the foregoing statement.

16.0 The Materialman shall complete the attached Form of Exception which clearly states any deviance to Technical Specifications proposed by the Bidder. Failure to state any deviance in the Materialman's Proposal from the Technical Specifications assumes complete and total compliance with the requirements of the Technical Specifications.

17.0 Change of Contract Price

A. The Contract Price may only be changed by a Change Order. The value of any Work covered by a Change Order or of any Claim for an adjustment in the Contract Price shall be determined as follows:

1. Where the Work involved is covered by unit prices contained in these Contract Documents, by application of such unit prices to the quantities of the items involved; or
2. Where the Work involved is not covered by unit prices contained in these Contract Documents, by mutually agreed unit prices or lump sum (which may include an allowance for overhead and profit); or
3. Where the Work involved is not covered by unit prices contained in these Contract Documents and agreement to a unit price or lump sum is not reached, on the basis of the Cost of the Work plus a CONTRACTOR's fee for overhead and profit.

B. CONTRACTOR shall establish and maintain records in accordance with generally accepted accounting practices and submit in a form acceptable to OWNER an itemized cost breakdown together with supporting data. OWNER may audit CONTRACTOR's records related to such costs during normal business hours.

C. The CONTRACTOR's total fee for overhead and profit shall not exceed 15% of the value of the additional work.

D. No increase in Contract Price shall be granted for Inexcusable Delays, unless otherwise agreed to by OWNER.

**FAYETTEVILLE PUBLIC WORKS COMMISSION
SPECIFICATIONS AND BID DOCUMENTS FOR
67KV Delta to 13.09Y/7.56KV Wye with LTC
24/32/40MVA POWER TRANSFORMERS**

MATERIALMAN'S PROPOSAL

TO: Fayetteville Public Works Commission (hereinafter called the "Commission")

The undersigned (hereinafter called the "Materialman") hereby proposes to sell and deliver to the Commission, upon the terms and conditions herein stated, the materials and equipment (hereinafter called the "Material") specified in the following schedule or schedules attached hereto and by this reference made a part hereof (hereinafter called the "Schedules") in accordance with the Bid Schedule and:

1. Technical Specifications for the Materials and Equipment for **67KV Delta to 13.09Y/7.56kV LTC Power Transformers.**
2. Instructions to Bidders.
3. Manufacturer's Specifications both as set forth herein and in manufacturer's literature (two sets) attached hereto or furnished separately as provided for in the "Instructions to Bidders."
4. Contract Documents.

The prices quoted herein:

1. Are firm.
2. Are FOB, substation transformer pad, at each substation site to be designated by the Commission and located within the Commission's service area in and surrounding Fayetteville, North Carolina.
3. The price shall include crane services, unloading, handling, rigging, and placement of each transformer on an existing cribbing or foundation at the site to be designated by the Commission.
4. The transformers shall be assembled (dressed out) and electrically tested by manufacturer.
5. Show North Carolina sales tax as a separate item.
6. Include service of the Manufacturers' Field Service Engineer for the number of days stated in the Materialman's Proposal with additional days or reimbursement for unused days at the daily rate stated in the Proposal.

The Materialman declares that it has examined the Technical Specifications for the work and the Contract Documents relative thereto, read all special provisions furnished prior to the opening of the bids, and satisfied himself relative to the work to be performed.

The Materialman proposes and agrees that if the following schedule or schedules of this Proposal are accepted, it will contract with the Fayetteville Public Works Commission, in the form of a Contract specified, to furnish all necessary materials and equipment, except materials and equipment specified to be furnished by the Commission, complete and in accordance with the Plans, Specifications, and Contract Documents, to the full and entire satisfaction of the Commission, with a definite understanding that no money will be allowed for extra work except as set forth in the General Conditions and Contract Documents, and as cited on Change Order Forms.

The following information is supplied regarding the materials and equipment on which this bid is based:

Manufacturer: _____

Manufacturer of LTC: _____

Type or Model: _____

Location or Manufacturing Facility: _____

Nearest Repair Facility: _____

Percent of Failure of last 100 power transformers at the factory testing: _____

Percent of Failure of last 100 power transformers after installed in field: _____

Other Utilities Purchasing Recent Units of Same Design: _____

MATERIALMAN'S PROPOSAL

SCHEDULE NO. 1

Description	Quantity	Price (Lump Sum Payment)
One Power transformers, rated 24/32.0/40.0 MVA LTC, 67 kV delta primary voltage, 13.09/7.56 kV grounded wye secondary voltage, including specified five-(5) year warranty, all in accordance with the Contract Documents. Shipment to occur on June 8, 2023, to the Cumberland Road Substation at 2336 Carbine Street, Fayetteville, NC 28306.	1	\$ _____
North Carolina Sales Tax		\$ _____
Total Unit Cost		\$ _____

Notes:

MAXIMUM GUARANTEED LOSSES

SCHEDULES 1⁽¹⁾

	<u>LTC 1R Pos</u>	<u>LTC⁽²⁾ Avg. 15R & 16R Pos.</u>
Maximum guaranteed no-load kW losses, 100% voltage, 75°C, 24MVA ⁽³⁾	_____ kW	_____ kW
Maximum guaranteed load kW losses, (not total losses) at 24MVA ⁽³⁾	_____ kW	_____ kW
Maximum guaranteed Total kW losses, at 24MVA, 75°C ⁽³⁾	_____ kW	_____ kW
Auxiliary kW losses, first stage cooling	_____ kW	_____ kW
Auxiliary kW losses, second stage cooling	_____ kW	_____ kW
Impedance %		_____ %

(1) All transformers in all bid schedules shall conform to these losses.

(2) These levels will be considered in evaluating the bids.

(3) No-load and total losses are to be guaranteed per ANSI or IEEE standards.

	Delivery (Weeks)*	
	Bid Schedule No. 1	
Approval Drawings **		
Final Drawings**		
Delivery* *		

1. The prices of Materials set forth herein do not include any sums which are or may be payable by the Materialman on account of County or North Carolina sales tax upon the sale, purchase, or use of the Materials hereunder. The amount thereof shall be added to the purchase price and paid by the Commission after the Materialman has ascertained the actual sales tax to be included.
2. The Materials will conform to the "Technical Specifications for 67KV to 13.09 x 7.56kV LTC Power Transformers" attached hereto and made a part hereof.

3. The prices quoted in the Materialman's Proposal shall be firm.
4. The prices quoted shall include delivery of the materials and equipment by truck or rail FOB Pad, Fayetteville, North Carolina, as outlined in the Instructions to Bidders. The point of delivery for each transformer will be designated by the Commission at least thirty (30) days prior to the scheduled delivery of each transformer.
5. The prices of the materials and equipment set forth herein shall include the cost of delivery to the site at the Materialman's risk. The time of delivery shall be as shown in this Proposal.

The time for delivery shall be extended for the period of any reasonable delay due exclusively to causes beyond the control and without fault of the Materialman, including but not limited to, acts of God, fires, floods, strikes, and delays in transportation.

Delivery of all items of equipment to the Commission's designated delivery point shall be made to permit unloading between the hours of 9:00 a.m. and 3:00 p.m., Monday through Thursday, holidays excluded.

6. Receipt of Approval Drawings by the Materialman constitutes authorization for manufacture predicated upon the Drawings and corrections found thereon. After the return of Approval Drawings, release for shipment is to be granted by either the Commission or its Engineer based upon the manufacturer's compliance with the following:
 - a. Fourteen (14) consecutive days prior notification of tests so the Commission may have a representative present to witness the tests.
 - b. Furnishing of the requested number of copies of the Final Drawings as called for in the Contract Documents.
 - c. Coordination of manufacturing and delivery with the Commission's construction schedule as may be noted in the Contract Documents.
 - d. Thirty (30) days' notification of the tentative shipping schedule and forty-eight (48) hours' notification prior to all deliveries.
 - e. The base quotation shall include the services of a Manufacturer's Field Service Engineer for the time outlined below per unit. Extra days (or credit for days not used) shall be supplied at a daily rate as quoted below:

Item	No. of Days Per Unit	<u>Daily Rate*</u>
LTC Power Transformer	_____	\$ _____

*Adjustment for exceeding five (5) days or credit for less than three (3) days.

7. Title to the materials and equipment shall pass to the Commission upon delivery on the pad, to the point specified above, and subject to successful final field testing and acceptance by the Commission or the Engineer.
8. This Proposal is made pursuant to the provisions of the Notice and Instructions to Bidders and the Technical Specifications, and the Materialman agrees to the terms and conditions thereof.
9. The Materialman warrants the accuracy of all statements contained in the Bidder's qualifications, if any shall be submitted, and agrees that the Commission shall rely upon such accuracy as a condition of the Contract in the event that this Proposal is accepted.
10. The Materialman warrants that the materials will conform to the performance data and guarantees which are attached hereto and by this reference made a part hereof.
11. NON-COLLUSIVE BIDDING CERTIFICATION - By the submission of this bid, the Materialman certifies that:
 - a. The bid has been arrived at by the Materialman independently and has been submitted without collusion with any other Materialman or Subcontractor of materials or equipment of the type described in the Notice to Prospective Bidders or the Technical Specifications.
 - b. The contents of the bid have not been communicated by the Materialman or, to its best knowledge and belief, by any of its employees or agents to any person not an employee or agent of the Materialman or its Surety on any Bond furnished herewith and will not be communicated to any person prior to the official opening of the bid.
 - c. The undersigned further agrees that in case of failure on its part to execute said Contract within ten (10) consecutive calendar days after written notice Notice of Award of Contract has been given, the check, cash, or Bid Bond accompanying this bid and the monies payable thereon shall be paid into the funds of the Commission account set aside for this project as liquidated damages for such failure; otherwise, the check, cash, or Bid Bond accompanying the Proposal shall be returned to the Undersigned.
12. The Materialman shall complete the attached Form of Exception which clearly states any deviance from the Contract Documents proposed by the Bidder. Failure to state any deviance in the Materialman's Proposal from the Contract Documents assumes complete and total compliance with the requirements of the Contract Documents.

Use this space for attaching check or cash:

FAYETTEVILL PUBLIC WORKS COMMISSION
FAYETTEVILLE, NORTH CAROLINA

One 67KV Delta to 13.09Y/7.56KV LTC POWER TRANSFORMERS

FORM OF EXCEPTIONS

BIDDER: _____

MANUFACTURER: _____

INSTRUCTIONS: The following is a list of exceptions to the Contract Documents and/or Technical Specifications pertaining to the furnishing of the subject materials. Bidders shall identify each exception by page and paragraph number on this form. The omission of exceptions implies complete compliance with Plans and Contract Documents.

CONTRACT DOCUMENT/

**PAGE NO. AND
PARAGRAPH**

EXCEPTION/VARIATION

_____	_____
_____	_____
_____	_____
_____	_____
_____	_____
_____	_____
_____	_____
_____	_____
_____	_____
_____	_____
_____	_____
_____	_____
_____	_____
_____	_____
_____	_____
_____	_____
_____	_____
_____	_____
_____	_____
_____	_____
_____	_____
_____	_____
_____	_____
_____	_____
_____	_____
_____	_____

1. If, in submitting this Proposal, the Materialman has made any exceptions to bid documents, the Materialman understands that the Commission will evaluate the effect of such exceptions in determining the award of the contract.

Respectfully submitted this _____ day of _____, 2022.

Name of Bidder

By _____

TITLE

Address of Bidder:

Manufacturer of Proposed
Equipment:

Place of Manufacture:

NORTH CAROLINA BID BOND

KNOW ALL MEN BY THESE PRESENT, THAT WE

as Principal, and _____ as Surety, who is duly licensed to act as Surety in North Carolina, are held and firmly bound unto the Fayetteville Public Works Commission, as Obligee, in the penal sum of _____ DOLLARS (\$ _____) (5% Bid Bond), lawful money of the United States of America, for the payment of which, well and truly to be made, we bind ourselves, our heirs, executors, administrators, successors, and assigns, jointly and severally, firmly by these present.

SIGNED, Sealed and dated this _____ day of _____, 2022.

WHEREAS, the said Principal is herewith submitting Proposal for

A 67KV Delta to 13.09Y/7.56 KV WITH LTC 24/32/40MVA POWER TRANSFORMERS

and the Principal desires to file this Bid Bond in lieu of making the cash deposit as required by N.C.G.S. §143-129;

NOW, THEREFORE, THE CONDITION OF THE ABOVE OBLIGATION is such that if the Principal shall be awarded the Contract for which the bid is submitted and shall execute the Contract and give Bond for the faithful performance thereof within ten (10) days after the award of same to the Principal, then this obligation shall be null and void; but if the Principal fails to so execute such Contract and give Bond as required by N.C.G.S. §143-129, , the Surety shall, upon demand, forthwith pay to the Obligee the amount set forth in the first paragraph hereof, and upon failure to forthwith make such payment, the Surety shall pay the Obligee an amount equal to double the amount of this Bid Bond as set forth in the first paragraph herein. Power of Attorney from the Surety to its Attorney-in-Fact is attached hereto.

Principal

By _____ (SEAL)

Corporate Surety

By _____ (SEAL)

SALE OF GOODS AGREEMENT

This Sale of Goods Agreement (“Agreement” or “Contract”) is made by and between the City of Fayetteville (the “City”), by and through the Fayetteville Public Works Commission (“PWC”), a North Carolina public authority, and

_____ [insert seller’s full legal name] (“Seller”), a
_____ [identify the type of legal entity and State in which
formation was accomplished] (each of PWC and Seller is a “Party” and both are collectively the “Parties”) as of the date of execution last written below (the “Effective Date”). The Parties agree as follows:

1. Sale of Goods. Seller shall sell to PWC and PWC shall purchase from Seller the following specifically manufactured good(s): One 67KV Delta to 13.09Y/7.56KV WITH LTC 24/32/40MVA POWER TRANSFORMERS (the “Goods”). PWC may issue a purchase order for the Goods that specifies any additional applicable terms and conditions set forth for the purchase (a “Purchase Order”), but such Purchase Order is subject to the terms of this Agreement. In the event of a conflict between the provisions of this Agreement and the provisions of any Contract Documents or attachment or exhibit or Purchase Order made pursuant to this Agreement, the terms of this Agreement shall govern.

2. Contract Documents. “Contract Documents” means the following documents that were either made available to Seller by PWC during the bid solicitation process (including Drawings) or executed by the Parties, or both, which are all incorporated by reference herein:

- a. This Agreement
- b. Notice to Prospective Bidders
- c. Definitions
- d. Instructions to Bidders
- e. General Conditions
- f. Materialman’s Proposal
- g. Bid Bond
- h. Technical Specifications
- i. Addenda as applicable
- j. Purchase Order

3. Delivery of Goods. Seller shall deliver the Goods as agreed in writing by the Parties (the “Delivery Date”). Timely delivery of the Goods is of the essence. If Seller fails to deliver the Goods on or before the Delivery Date, PWC may, without any liability to Seller, terminate this Agreement immediately by providing written notice to Seller. Unless otherwise specified in an applicable Purchase Order or the Contract Documents, excluding this Agreement, all Goods shall be delivered to PWC’s Warehouse at 955 Old Wilmington Road, Fayetteville, North Carolina 28301 (the “Delivery Point”) during PWC’s normal business hours. Delivery shall be made FOB Delivery Point.

4. Title and Risk of Loss. Title of the Goods passes to PWC upon delivery of the Goods to the Delivery Point. Seller bears all risk of loss or damage to the Goods until delivery of the Goods to the Delivery Point.

5. Packaging. Seller shall properly pack, mark, and ship the Goods as instructed by PWC and otherwise in accordance with applicable law and industry

standards and shall provide PWC with all shipment documentation showing the quantity of pieces in shipment, the number of cartons or containers in shipment, Seller's name, the airway bill or bill of lading number, and the state of origin.

6. Inspection and Rejection of Nonconforming Goods. PWC has the right to inspect the Goods on or after the Delivery Date. PWC, at its sole option, may inspect all or a sample of the Goods, and may reject all or any portion of the Goods if it determines the Goods are nonconforming or defective. If PWC rejects any portion of the Goods, PWC has the right, effective upon written notice to Seller, to: (a) terminate this Agreement in its entirety and require Seller to remove the Goods in a commercially reasonable time period or pay the full cost and expense to have the rejected Goods returned to Seller; or (b) reject the Goods and require replacement of the rejected Goods at Seller's sole expense. If PWC requires replacement of the Goods, Seller shall, at its sole expense and in the lesser of ninety (90) days or the number of days between any applicable Purchase Order of PWC and the Delivery Date, replace the nonconforming Goods and pay for all related expenses, including, but not limited to, transportation charges for the return of the defective goods and the delivery of replacement Goods. Any inspection or other action by PWC under this section shall not reduce or otherwise affect Seller's obligations under this Agreement, including Seller's warranties, and PWC shall have the right to conduct further inspections after Seller has carried out its remedial actions.

7. Price. PWC shall purchase the Goods from Seller in the total amount of \$_____ ("Price"). The Price includes all packaging, transportation costs to the Delivery Location, insurance, fees, and applicable taxes, including, but not limited to, all sales, use, or excise taxes. No increase in the Price is effective, whether due to increased material, labor, transportation costs or otherwise, without the prior written consent of PWC.

8. Billing and Payment. Seller shall invoice PWC within thirty (30) days after the completion of the delivery of the Goods. PWC shall pay the undisputed portion of the invoice within forty-five (45) calendar days after PWC's receipt of the invoice. All payments from PWC to Seller shall be transferred electronically to Seller's designated financial institution, and Seller shall, prior to delivery of its invoice to PWC, supply the name of Seller's financial institution, routing number, and account number on the form available from PWC and provide to PWC a completed and signed IRS Form W-9. Seller has the right to impose a late payment charge of one percent (1%) per month for amounts unpaid by PWC by the date due.

9. Warranties. Seller warrants to PWC that for a period of twenty-four (24) months from the Delivery Date, all Goods will: (a) be free from any defects in workmanship, material and design; (b) conform to applicable specifications, drawings, designs, samples and other requirements set forth in the Contract Documents or as specified by PWC and agreed to by Seller; (c) be fit for their intended purpose and operate as intended; (d) be free and clear of all liens, security interests, or other encumbrances; and (e) not infringe or misappropriate any third party's patent or other intellectual property rights. These warranties survive any delivery, inspection, acceptance or payment of or for the Goods by PWC. These warranties are cumulative and in addition to any other warranty provided by law or equity. Any applicable statute of limitations runs from the date of PWC's discovery of the noncompliance of the Goods with the foregoing warranties. If PWC gives Seller notice of noncompliance with this Section 9, Seller shall, at its own cost and expense, within thirty (30) days replace or repair the defective or nonconforming Goods and pay for all related expenses, including, but not limited to, transportation charges for the return of the defective or nonconforming goods to Seller and the delivery of repaired or replacement Goods to PWC.

10. Termination. Notwithstanding any other or additional remedies that may be provided under this Agreement, PWC may terminate this Agreement with immediate effect upon written notice to the Seller, either before or after the acceptance of the Goods, if: (a) Seller repudiates, or threatens to repudiate, any of its obligations under this Agreement; (b) Seller is in breach of, or threatens to breach, any representation, warranty, or covenant of Seller under this Agreement and either the breach cannot be cured or, if the breach can be cured, it is not cured by Seller within a commercially reasonable period of time under the circumstances, in no case exceeding seven (7) days following Seller's receipt of Notice of such breach; (c) Seller fails to, or threatens to fail to, timely deliver Goods conforming to the requirements of, and otherwise in accordance with, the terms and conditions of this Agreement; or (d) Seller becomes insolvent, files a petition for bankruptcy, or commences or has commenced against it proceedings relating to bankruptcy, receivership, reorganization, or assignment for the benefit of creditors. PWC shall be obligated to pay Seller only for work performed and reasonable expenses incurred until delivery of the notice of termination.

11. Insurance. During the term of this Agreement and for a period of three (3) years after the date of this Agreement, Seller shall, at its own expense, maintain and carry insurance in full force and effect that includes, but is not limited to, commercial general liability (including product liability) with limits no less than \$1,000,000 for each occurrence and \$3,000,000 in the aggregate and umbrella liability in a sum no less than \$5,000,000, which insurance shall be placed with insurance companies authorized to do business in the State of North Carolina and rated A minus VII or better by the current edition of Best's Key Rating Guide or otherwise approved in writing by PWC. Prior to delivering any Goods, Seller shall deliver to PWC certificates of insurance confirming each such coverage, and Seller shall direct its insurers to provide annually to PWC certificates confirming each such coverage during the coverage period. PWC shall be named as an additional insured in the insurance policy. Seller shall not reduce or allow the required insurance coverages to lapse without PWC's prior written approval. All policies for insurance must be endorsed to contain a provision giving PWC a thirty (30) calendar day prior written notice by certified mail of any cancellation of that policy or material reduction in coverage. Should a notice of cancellation be issued for non-payment of premiums or any part thereof, or should Seller fail to provide and maintain certificates as set forth herein, PWC shall have the right, but not the obligation, to pay such premium to the insurance company or to obtain such coverage and to deduct such payment from any sums that may be due or become due to Seller, or to seek reimbursement for said payments from Seller. Any such sums paid by PWC shall be due and payable immediately by Seller upon notice from PWC. The insurance provisions of this Agreement shall not be construed as a limitation on Seller's responsibilities and liabilities pursuant to the terms and conditions of this Agreement.

12. Indemnification. Seller shall indemnify, defend, and hold harmless PWC and its Commissioners, officers, employees, agents, and representatives (collectively, "Indemnitees") from and against all claims, actions, liabilities, damages, losses, costs, and expenses (including, without limitation, injury to or death of any persons and damage to property, economic and consequential damages and attorneys' fees) asserted by one or more third parties against one or more of the Indemnitees arising out of negligent or willful acts, violations of law, infringement of any patent, trademark, trade secret, copyright, or other intellectual property right of a third party, or omissions or breach of the obligations set forth in this Agreement by Seller or any of its employees, agents, representatives, and subcontractors. Seller's obligation to indemnify, defend, and hold harmless the Indemnitees shall survive the termination of this Agreement and shall include the duty to

pay for the reasonable attorney's fees and costs associated with defending the Indemnitee(s) by the legal counsel of each Indemnitee's choice.

13. Notices. Any notice which either Party is required or desires to give the other shall be deemed sufficiently given if, in writing, it is delivered personally, or sent by certified U.S. mail, return-receipt requested, postage prepaid, to the addresses listed hereinbelow, or such other address as either Party shall give to the other Party by written notice in accordance herewith. Any notice given herein by personal delivery shall be deemed delivered when received. Any properly addressed notice given herein by certified mail shall be deemed delivered on the third Business Day after the same is deposited in an official United States Post Office, postage prepaid, or if sooner upon the date when the return receipt therefor is signed, or refusal to accept the mailing by the addressee is noted thereon by the postal authorities.

To PWC:
Fayetteville Public Works Commission
Attn: Elaina L. Ball, CEO/General Manager
PO Box 1089
Fayetteville, NC 28302

To Seller:
[INSERT MAILING ADDRESS]

14. Compliance. Seller hereby acknowledges that "E-Verify" is the federal E-Verify program operated by the US Department of Homeland Security and other federal agencies which is used to verify the work authorization of newly hired employees pursuant to federal law and in accordance with Article 2, Chapter 64 of the North Carolina General Statutes. Seller further acknowledges that all employers, as defined by Article 2, Chapter 64 of the North Carolina General Statutes, must use E-Verify and after hiring an employee to work in the United States, shall verify the work authorization of the employee through E-Verify in accordance with NCGS §64-26(a). Seller hereby pledges, attests, and warrants through execution of this Agreement that Seller complies with the requirements of Article 2, Chapter 64 of the North Carolina General Statutes and further pledges, attests, and warrants that all subcontractors currently employed by or subsequently hired by Seller to provide services for PWC shall comply with all E-Verify requirements. Failure to comply with the above requirements shall be considered a breach of this Agreement. Seller hereby further acknowledges that the execution and delivery of this Agreement constitutes Seller's certification to PWC and to the North Carolina State Treasurer that, as of the Effective Date, Seller is not listed on (a) the Final Divestment List created and maintained by the North Carolina Department of State Treasurer pursuant to the Iran Divestment Act of 2015, Chapter 147, Article 6E of the General Statutes of North Carolina (the "Iran Divestment Act"); or (b) the list of companies that the North Carolina State Treasurer determines to be engaged in a boycott of Israel in accordance with Article 6G of Chapter 147 of the General Statutes of North Carolina. Seller represents and warrants to Commission that Seller, and all persons and entities owning (directly or indirectly) an ownership interest in it: (i) are not, and will not become, a person or entity with whom a party is restricted from doing business with under regulations of the Office of Foreign Asset Control ("OFAC") of the Department of the Treasury (including, but not limited to, those named on OFAC's Specially Designated and Blocked Persons list) or under any statute, executive order (including, but not limited to, the September 24, 2001, Executive Order 13224 Blocking Property and Prohibiting Transactions with Persons Who Commit, Threaten to Commit, or Support Terrorism), or other governmental action; and (ii) are not knowingly engaged in, and will not knowingly engage in, any dealings or transactions or be otherwise associated with such persons or entities described in clause (i) above. Seller

also shall at all times during the term of this Agreement comply with Executive Order 11246, including but not limited to the Equal Opportunity Clause requirements set forth in 41 C.F.R. § 60-1.4. Seller shall abide by the requirements of 41 CFR 60-300.5(a) and 60-741.5(a) prohibiting discrimination against qualified individuals on the basis of protected veteran status or disability and requiring affirmative action by covered prime contractors and subcontractors to employ and advance in employment qualified protected veterans and individuals with disabilities.

15. Cumulative Remedies. All rights and remedies provided in this Agreement are cumulative and not exclusive, and the exercise by either Party of any right or remedy does not preclude the exercise of any other rights or remedies that may now or subsequently be available at law or in equity.

16. Miscellaneous Provisions. Seller is and shall remain an independent contractor. Nothing contained in this Agreement shall be deemed or construed to create the relationship of principal and agent or of partnership or of joint venture or of any association whatsoever between the Parties. No breach or non-performance of any term of this Agreement shall be deemed to be waived by either Party unless said breach or non-performance is waived in writing and signed by the Parties. No waiver of any breach or non-performance under this Agreement shall be deemed to constitute a waiver of any subsequent breach or non-performance, and for any such breach or non-performance each Party shall be entitled to such remedies as provided by law. No consent or waiver by a Party shall be effective unless it is in writing and then only to the extent specifically stated. The invalidity, illegality, or un-enforceability of any portion or provision of this Agreement shall in no way affect the validity, legality, and/or enforceability of any other portion or provision of this Agreement. Any invalid, illegal, or unenforceable provision of this Agreement shall be deemed severed from this Agreement, and the balance of the Agreement shall be construed and enforced the same as if the Agreement had not contained any portion or provision which was invalid, illegal, or unenforceable; provided, however, severability shall not prevent this entire Agreement from being void in the event any portion or provision of this Agreement that is of the essence of this Agreement shall be void. This is the entire agreement of the Parties on the subject matter hereof, and all prior negotiations, representations, proposals, letters, agreements, understandings, or other communications between the Parties, whether written or oral, are hereby merged into the Agreement and superseded by this Agreement. This Agreement shall not be modified unless such modifications are evidenced in writing, signed by both Parties. Nothing herein shall be construed to give any right or benefits hereunder to anyone other than the Parties. This Agreement shall be governed by the laws of the State of North Carolina without the application of the laws of any other state. The exclusive venue for all mediations and litigation and any other legal proceedings regarding this Agreement shall be the State and Federal Courts serving Cumberland County, North Carolina, and Seller consents to personal jurisdiction in such courts. Seller irrevocably waives, to the fullest extent permitted by law, any objection that it may now or hereafter have to the laying of the venue of any such suit, action or proceeding in any such court serving Cumberland County or that any such suit, action or proceeding brought in any such court serving Cumberland County has been brought in an inconvenient forum. This Agreement may be executed in counterparts with the same effect as if the signatures to each counterpart were upon a single instrument, and all such counterparts together shall be deemed an original of this Agreement. For purposes of this Agreement, a facsimile copy or scanned copy or photocopy of a party's signature shall be sufficient to bind such party. This Agreement shall be subject to execution by electronic means in accordance with Article 40 of Chapter 66 of the North Carolina General Statutes. The titles of the paragraphs throughout this Agreement are for convenience only and the words contained therein shall in no way be

held to explain, modify, amplify, or aid in the interpretation, construction, or meaning of the provisions of this instrument.

17. Conflicts. Except with PWC's knowledge and prior written consent, the Seller shall not engage in any activity or accept any employment, interest or contribution that would reasonably appear to compromise the Seller's professional judgment with respect to the Goods. The Seller shall disclose to PWC any business or personal relationship with any Commissioner, officer, director, manager, or supervisor of PWC.

IN WITNESS WHEREOF, the Parties have executed this Agreement by their duly authorized representatives.

Fayetteville Public Works Commission
[NAME]

[INSERT SELLER'S FULL LEGAL

By: _____

By:

Elaina L. Ball, CEO/General Manager

[Title]

[Printed Name]

Date: _____

Date:

This instrument has been preaudited in the manner required by the Local Government Budget and Fiscal Control Act (N.C. Gen. Stat. § 159-1 et seq.).

By: _____
Rhonda Haskins, Chief Financial Officer

Approved as to form:

James P. West, Chief Legal Officer

FAYETTEVILLE PUBLIC WORKS COMMISSION

One 67KV Delta to 13.09Y/7.56KV WITH LTC 24/32/40MVA POWER TRANSFORMERS

TECHNICAL SPECIFICATIONS

1.0 Scope

The Fayetteville Public Works Commission seeks firm quotations for power transformers based upon placement of orders in 2022. One (1) bid schedule has been established to achieve the following:

Purchase of (1) 24MVA LTC power transformer to be shipped by Manufacturer on June 8, 2023. Firm quotations should be based upon placement of an order within sixty (60) days from bid date.

Bid Schedule No. 1:

The Commission has the right to select or reject any or all schedules, adders, or deducts (or combination thereof) listed in the Proposal. The Commission intends to place orders for one (1) transformer within sixty (60) days from the bid opening date.

Base quotations for each transformer shall include the Materialman's risk of delivery, unloading, handling, rigging, and placement of the transformer onto the Commission's foundation pad or foundation piling at each site to a substation site located within the Commission's service area in and surrounding Fayetteville, North Carolina. The Commission will designate the specific delivery site for each transformer at least thirty (30) days prior to the Manufacturer's scheduled delivery. The Commission will provide reasonable roadworthy access to each site.

2.0 General Conditions

- 2.1 All materials and equipment shall be new.
- 2.2 The Technical Specifications describe the type, size, and characteristics of the various materials and equipment required to be furnished. The Drawings indicate general arrangement, equipment location, and spacing.
- 2.3 Strict adherence to the Technical Specifications and Drawings is requested to facilitate checking and consideration of the Proposal.

- 2.4 Proposals shall include the following:
- 2.4.1 Catalog numbers, manufacturer, ratings, characteristics, types, sizes, etc., of all major removable materials and equipment included. A simple statement that all necessary materials and equipment will be provided is not satisfactory.
 - 2.4.2 Performance data and evidence of short circuit testing for similar designs for the several items as set forth in the Detailed Specifications.
 - 2.4.3 The Bidder shall state in its Proposal the manner in which the transformers will be shipped, namely, truck or rail; whether units shall be shipped oil-filled; and whether bushings will be installed or removed.
 - 2.4.4 Prices shall include the cost of delivery to the substation site and unloading onto the pad as per Instructions to Bidders.
 - 2.4.5 It is the intent of these Technical Specifications that the transformer shall be complete and fully operable. Any details not mentioned in the Technical Specifications but required for satisfactory operation shall be furnished and installed by the Materialman including top off oil.
 - 2.4.6 Station power available at the Commission's substation will be 120/240 volts, 60 Hz, single-phase. Control DC voltage at the substation sites will be 48 volts. The equipment on the transformers shall coordinate with these voltages as appropriate.

3.0 Special Conditions

3.1 Defective Materials, Equipment, and Workmanship

3.1.1 All materials and equipment furnished hereunder shall be subject to the inspection, tests, and approval of the Commission and the Materialman shall furnish all information required concerning the nature or source of any materials and equipment and provide adequate facilities for testing and inspecting the materials and equipment at the plant of the Materialman.

3.1.2 Basic Right of Rejection

The materials and equipment furnished hereunder shall become the property of the Commission when delivered at the point to which shipment is to be made, provided, however, that the Commission may reject any such materials and equipment that do not comply with the Technical Specifications and warranties of the Materialman and manufacturers. Recognition and subsequent rejection of any defective materials and equipment may occur either before or after incorporation of such materials and equipment into the facilities, provided such rejection is made within sixty (60) days of date of energization of the materials and equipment. Upon any such rejection, the Materialman shall replace the rejected materials and equipment with materials and equipment complying with the Technical Specifications and warranties, F.O.B. truck at suitable destination. The Commission shall return the rejected materials F.O.B. truck at the same destination.

The Uniform Commercial Code UCC §§ 2-601 and 2-602 will be the guideline for the "Perfect Tender Rules" for such terms as "rejection, acceptance, and inspection".

In the event of the failure of the Materialman to so replace rejected materials and equipment, the Commission may make such replacement and the cost and expense thereof shall be paid by and recoverable from the Materialman.

3.1.3 The transformer to be provided herein shall include a full five (5) year warranty on the complete transformer together with all parts. This warranty shall extend for five (5) years from the date of delivery.

3.2 Miscellaneous

The Materialman shall hold harmless and indemnify the Commission, its agents, and its employees from any and all claims, suits, and proceedings for infringement of any patent or patents covering materials and equipment purchased hereunder. The Materialman shall defend any suit or proceeding brought against the Commission, its agents, or its employees based upon a claim that the materials and equipment or any part thereof constitute an infringement of any patent, or if the Materialman shall fail to defend such suit or proceeding, the Commission may do so and the Materialman shall make reimbursement for the expense of such litigation. If the materials and equipment or any part thereof are held to constitute infringement and the use thereof is enjoined, the Materialman shall, at its own expense, either procure for the Commission the right to continue to use the materials and equipment or such part thereof or shall replace the materials and equipment or such part thereof with non-infringing materials and equipment.

4.0 Standards

All equipment and materials covered by the Technical Specifications and all tests applied thereto shall, unless otherwise stated herein, be in accordance with the applicable provisions of the latest editions of the Standards of the ASTM, ANSI, AEIC, IEEE, NEMA, NESC, and OSHA.

Where the term "Standards" is used in the Specifications it shall be understood to refer to the above Standards.

5.0 Drawings

5.1 Preliminary

Before proceeding with fabrication, the manufacturer shall submit for approval sufficient Drawings to demonstrate that all parts conform to the requirements and intent of the Technical Specifications. The Drawings shall include four (4) copies each of Outline, Nameplate, Detail, Control, Elementary, and Control Wiring Drawings. All Drawings submitted shall be a minimum of a "D" (24" x 36") size print. Submittal of Drawings smaller than "D" size will be immediately returned stamped "not approved" and proper size Drawing will have to be submitted. All Drawings shall be dimensioned in feet and inches; metric measurements alone will not be acceptable. However, dual dimensioning in feet and inches and centimeters will be acceptable. Approval Drawings shall be submitted directly to the Commission, Fayetteville PWC, 955 Old Wilmington Road, Fayetteville, North Carolina 28301, and Attention: Joel C. Valley

The Outline Drawing shall show dimensions of equipment including bushings, radiators and cooling equipment, base, and all other important external features. These Drawings shall show weights, bushing catalog numbers, ampere ratings, and descriptions of top bushing terminals and arrangement of all external accessory devices, as well as the complete transformer rating.

Approval of Drawings shall not be held to relieve the Materialman of obligations to meet all requirements of the Technical Specifications, of responsibility for correctness of the Drawings, or of responsibility to meet original shipping promise on basis of Commission's Engineer being allowed two weeks for approval.

Receipt of Approval Drawings by the Materialman constitutes authorization for manufacture only, based upon the corrections found thereon. The Commission's Engineer reserves the right to request resubmittal of Drawings as deemed appropriate prior to authorizing manufacture.

5.2 Final Drawings

Contingent upon Approval Drawing review and product manufacture, the Bidder shall issue final documentation for the transformer as follows:

- 5.3 One (1) complete set of all Drawings, revised to "as-built" status, released on paper media.
- 5.4 Two (2) complete sets of all Drawings, revised to "as-built" status, released on two (2) separate CD-ROMs, compatible with AutoCad, Release 2010.
- 5.5 Four (4) copies of applicable instruction books, including one (1) print each of all Drawings representing physical and electric details as furnished per paragraph 5.2.1.
- 5.6 Two (2) copies of certified test reports corresponding to functional performance measurements after final assembly.
- 5.7 All Drawings are to be certified correct and supplied within a reasonable length of time prior to shipment of the equipment. Each set of Drawings and documentation shall include the following information:
 - 5.8 Outline and Assembly Drawings showing size and location of major components and all principal dimensions.
 - 5.9 Control cabinet front view.
 - 5.10 Details of bushing and bushing terminal connectors.
 - 5.11 Diagram of bushing current transformers, connection, number of turns, polarity marking, ratios, and bushing orientation.
 - 5.12 Current transformer performance characteristic curves and data for all relay accuracy CT's.

- 5.13 Details of control housing.
- 5.14 Panel connection diagram showing exact connection for all components furnished.
- 5.15 AC and DC elementary circuit diagrams for all relay and control equipment furnished.
- 5.16 Wiring control and schematic diagrams.
- 5.17 Instruction books, including LTC operations manual(s), if so equipped.
- 5.18 Renewal parts catalog.
- 5.19 Two (2) copies of certified test reports.

6.0 Shipping of Transformer

- 6.1 Each transformer shall be shipped to a substation site to be specifically designated by the Commission at least thirty (30) days prior to the Manufacturer's scheduled delivery date. The Manufacturer shall furnish adequate capacity crane for unloading, handling, rigging, and placement of the transformer onto the Commission's foundation.
- 6.2 Before shipment, transformer shall be completely assembled to determine if all parts fit properly. Parts removed for shipment shall be marked to permit easy identification when reassembling. Assembly of any component parts removed for shipment will be performed by manufacture's field labor or a hired contractor by the manufacture and to be under the supervision of the manufacturer's field service engineer.
- 6.3 Method of packing and loading shall ensure protection of all parts from dampness, corrosion, breakage, or vibration injury that might reasonably be encountered in transportation, storage, and handling.
- 6.4 Release for shipment is to be granted by either the Commission or the Commission's Engineer based upon the manufacturer's compliance with the following:
Fourteen (14) consecutive days prior notification of tests, so the Commission may have a representative present for witness of the tests.
- 6.5 Furnishing of the requisite number of copies of the Final Drawings as called for in the Specifications.
- 6.6 Thirty (30) days' notification of tentative shipping schedule and forty-eight (48) hours' notification prior to delivery.
- 6.7 A three-direction impact recorder with GPS shall be installed to travel on the transformer for shipment and shall remain on the unit until it is unloaded unless the Materialman is relieved of this requirement by the Commission's Engineer. The impact recorder shall be read prior to unloading, at the rail siding prior to unloading if applicable, on the trailer prior to transportation to the site, and after arrival at the site.

- 6.8 Transformer may be shipped oil-filled with the low-voltage bushings installed unless otherwise stated at the time of bid. The Materialman shall state method of shipment, and this shall be evaluated when awarding the Contract. The Commission prefers that the transformer be shipped oil-filled with the low-voltage bushings installed. Materialman must provide top off oil for when adding radiators.
- 6.9 If the transformer is not shipped oil-filled, it shall be shipped dry-air-filled and equipped with proper pipe connections for checking and filling under vacuum. The oil shall be shipped by tanker with the unloading facility (pump) furnished. The unloading facility shall have been flushed free of undesirable contaminants by flushing with the same type oil provided for the transformer. The Materialman shall furnish all equipment and supervision required for filling, and the Materialman shall coordinate timing and arrangements.
- 6.10 The Materialman's bid will be evaluated as having a forty-thousand-dollar (\$40,000) adder if complete oil-filling of the transformer is not provided in their base quote.
- 6.11 Type of shipment (oil-filled or dry-air-filled) shall be specified in the Proposal.

7.0 Manufacturer's Field Representative

The manufacturer shall provide the services of a Field Service Engineer for a period of up to five (5) working days per unit. The duties of the Field Service Engineer shall be to supervise a contractor hired or provide field labor by the manufacture of the transformer for the installation of component parts removed for shipment, including but not limited to bushings, radiators, surge arresters, and top off oil. He shall supervise installation of all control and auxiliary wiring of contractor. Once re-assembled, the transformer will be completely field tested by the Field Service Engineer as may be noted in Section 10.0 of these Technical Specifications. Additional time required shall be performed at the per-day rate quoted in the Proposal. This same rate shall apply as a deduction for any days included in the base bid which are not used.

8.0 Transformer

8.1 Type and Rating

- 8.1.1 The transformer shall be three-phase, 60 Hertz, two-winding, suitable for outdoor service at an altitude less than one kilometer (3300 feet) above sea level.
- 8.1.2 High voltage shall be 67,000 volts delta at 350 kV BIL and low voltage shall be 13,090/7,560 volts wye, 110 kV BIL. High voltage shall lead low voltage by 30° phase angle. The transformer will be operated with the neutral tied solidly to ground. All windings shall be copper and circular in design; where the High Voltage (HV) windings are made of Strand wire copper and Continuously Transposed Copper CTC copper is suitable design, such as; parallel winding for the Low Voltage side (LV) but is not required in all multiple conductors turns.
- 8.1.3 The transformer shall be oil-immersed for continuous self-cooled/forcedair-cooled operation ONAN/ONAF/ONAF with two (2) stages of cooling and shall be furnished complete with oil. Fans shall be included with the transformer. The operating voltage for fans shall be 240 volts, single phase.

- 8.1.4 Transformer ratings, when loaded in accordance with IEEE C57.92 (1981 ed.) "Guide for Loading Oil-Immersed Distribution and Power Transformers," shall be as follows:

<u>Schedule No 1</u>	
55°C rise, ONAN	24,000 kVA
65°C rise, ONAN	26,800 kVA
55°C rise, ONAN/ONAF	32,000 kVA
65°C rise, ONAN/ONAF	35,840 kVA
55°C rise, ONAN/ONAF/ONAF	40,000 kVA
65°C rise, ONAN/ONAF/ONAF	44,800 kVA

- 8.1.5 The transformer shall be capable of carrying rated load continuously at five percent (5%) above rated secondary voltage without exceeding an average winding temperature rise of 55°C above a 40°C maximum ambient and 30°C average ambient over twenty-four (24) hours.
- 8.1.6 The transformer shall be 55/65°C construction where the winding temperature rise by resistance will not exceed 65°C; hottest-spot winding temperature rise will not exceed 80°C. The transformer shall be suitable for loading in accordance with IEEE C57.92 (current edition) "Guide for Loading Oil-Immersed Distribution and Power Transformers."
- 8.1.7 The transformer shall be suitable for loading in accordance with the latest revision of NEMA "Guide for Loading Oil-Immersed Power Transformers with 65°C Average Winding Rise," Pub. No. TR98.

8.2 High-Voltage Taps

- 8.2.1 The transformer shall have full-capacity, high-voltage taps at maximum rated kVA provided as follows:

70,600 Volts
 68,800 Volts
 67,000 Volts
 65,200 Volts
 63,400 Volts

- 8.2.2 A weatherproof, hand-operated, tap-changing mechanism shall be provided suitable for de-energized operation of the high-voltage taps, with an external handle that may be operated from the transformer base level and have provision for locking in any position. An external indicator shall clearly display the tap position which is set.

8.3 Low-Voltage

- 8.3.1 The transformer shall have a single-voltage secondary winding, grounded Wye, providing full capacity at maximum kVA:

8.4 Tank and Cover

- 8.4.1 To achieve uniformity and compliance with the Commission's standard design for substation facilities, each transformer tank design shall observe the following criteria for location of external equipment and accessory hardware:
- 8.4.2 The control cabinet housing all low voltage wiring associated with current transformer secondary's, automatic fan control, alarms, LTC control, etc. shall be located on the side of the tank in Segment 1 as identified by IEEE C57.12.10.
- 8.4.3 The LTC compartment shall be located on the side of the tank in either Segment 2 as identified by IEEE C57.12.10-(current edition).
- 8.4.4 The control cabinet and the LTC compartment must be positioned to provide any substation operator a clear and unobstructed view of the LTC position indicator while standing at the control cabinet operating panel.
- 8.4.5 Auxiliary cooling equipment including USA manufactured radiators, USA manufactured fans, and pumps, shall be located on the side of the tank in either Segment 2 or Segment 3 as identified by IEEE C57.12.10. Placement of radiators shall not obstruct the operator's view of any indicating dial or gauge located within Segment 1 of the transformer.
- 8.4.6 Final placement of the control cabinetry, LTC compartment, LTC position indicator, radiators, and all other external auxiliary equipment shall be subject to the approval of the Commission. Relocation of these components will be required only as necessary to physically comply with the Commission's standard facilities design for foundations, oil containment systems, and surrounding substation structures.
- 8.4.7 The tank shall be designed and braced for full vacuum and shall be suitable for filling with oil under a vacuum of twenty-eight inches (28") of mercury in the field.
- 8.4.8 Containing tank shall not leak oil. Welded joints and seams shall be employed wherever practicable. Tank must not have seams on corners of tank.
- 8.4.9 Main transformer cover shall be welded. Gasketed joints for manhole covers, bushings, and other bolted attachments shall be sealed with a durable and reusable gasket material (ordinary cork or corkprene not approved) and shall be designed to permit their being made oil-tight in reassembly. Mechanical stops shall be provided to prevent crushing (controlled compression).

- 8.4.10 Transformer base shall be suitable for sliding the transformer in a direction parallel to either center line of the tank and shall be capable of supporting the transformer on two (2) pier foundations.
- 8.4.11 All surfaces of case and covers, both exterior and interior, shall be thoroughly cleaned by means of shot-blasting or by any other equally effective method. At least three (3) coats of exterior paint are to be applied. Total paint thickness on the transformer tank and control box shall be 5 mils, minimum. The hot-dipped galvanized coatings shall be 2.16-mils. minimum thickness on all transformer radiators.
- 8.4.12 The exterior surface of all bolts, nuts, and washers shall be primed and painted as above or such parts shall be stainless steel or galvanized. No exposed cadmium-plated or zinc chromate-plated parts will be allowed.
- 8.4.13 Paint shall be standard light gray, ANSI No. 70, and certified as lead free.
- 8.4.14 The bottom of the transformer tank shall not bear on the concrete pad in the finished installation. The bottom shall be primed and painted as described above. Flat-bottom transformers shall be furnished with supporting spacer beams. The dimensions and locations of these beams shall be shown in the manufacturer's Drawings.
- 8.4.15 The transformer tank shall be furnished with support brackets to mount a grounding/neutral bus of 4" x 1/4" (minimum) copper. The copper shall be tinned at all connection points and the copper bar shall be painted with ANSI Gray 70 paint. The grounding bus shall be supplied by the manufacturer and designed for attachment to the Xo neutral bushing, the base of all surge arresters, and to tank ground pads (loop configuration). Support points shall be at four feet maximum spacing from the tank base to the top surface, on two (2) diagonal corners. (See the attached Drawing identified as Appendix 2 for a typical grounding layout.)

8.5 Impedance

The LTC transformer impedance at the base rating shall be nine percent (9%) at 75°C with ANSI or IEEE standard tolerances for 67,000 volts, 350 kV BIL.

8.6 Sound Level

- 8.6.1 The transformer will be designed so that the average sound level will be in accordance with the latest revision of NEMA TR-1.
- 8.6.2 The sound level at the 24MVA self-cooled rating shall not exceed 72 dBA when factory-tested in accordance with the procedure stated in NEMA TR1-9.04.

8.7 Bushings and Terminals

- 8.7.1 The transformer shall be provided with three (3) primary and four (4) secondary cover-type bushings constructed of high-strength, wet-process porcelain.

- 8.7.2 All high-voltage bushings shall be Lapp or ABB manufactured oil-filled and dimensionally interchangeable between circuit breakers and transformers according to latest revisions of IEEE Standard. High-voltage bushings shall be rated 69 kV, 350 kV BIL, 1,200 amperes bottom connection C76, with C1 test ports. Low-voltage bushings shall be rated 27 kV, 150 kV BIL, **3,000** amperes bottom connection. All bushings shall be light gray, standard creepage. The High Voltage bushings shall be condenser-type and have provisions for power factor testing on C1.
- 8.7.3 Primary and secondary bushings shall be provided with copper thread studs sited in accordance with their respective current ratings. A connection suitable for flat spade connection with NEMA four-hole drilling shall be either built into the bushing or furnished as a separate item. High-voltage and low-voltage terminal studs and flat spade terminal connectors shall have silver-plated contact surfaces.
- 8.7.4 Secondary neutral bushing shall be provided with a connection for flat spade connections with NEMA four-hole drilling and connected to a 4" x 1/4" (minimum) copper bus extending from the terminal to a tank ground pad for direct connection to the station ground system. Refer to Appendix 2 for a typical grounding layout.
- 8.7.5 The bushings shall be spaced to comply with or exceed minimum phase-to-phase and phase-to-ground external clearances between live parts in accordance with IEEE and NESC Standards, and as per dimensions outlined in Appendix 3.

8.8 Auxiliary Cooling

- 8.8.1 Cooling equipment shall be furnished in accordance with ANSI or IEEE standards for transformer self-cooled and forced-cooled ratings of ONAN/ONAF/ONAF.
- 8.8.2 All cooling radiators shall be hot dipped galvanized, manufactured in the USA by Menks or Trantech, and mounted either in Segment 2 or Segment 3 as identified by IEEE C57.12.10, and as described in subparagraph 8.4.1 of these Technical Specifications. Final location of the radiators on the tank wall shall be subject to the approval of the Commission or the Commission's Engineer.
- 8.8.3 Provisions shall be made for cooling radiators to be mounted independently of one another on the transformer and individually removable from the transformer tank. Radiators shall be designed and braced to withstand all vibration and operating forces. The Commission would like radiators mount on separate support rack to elevate stress on the radiators.
- 8.8.4 Radiator mounting flanges on the transformer tank shall each be equipped with double flanged valves to permit the removal or replacement of an individual cooling radiator without loss of either oil or gas above oil in the transformer tank.

- 8.8.5 Each cooling radiator shall be equipped with a fill valve at the top and a drain valve at the bottom of the unit.
- 8.8.6 All cooling fans (and/or pumps) shall be USA manufactured and utilize the SEL 2414 transformer monitor to provide the operation of all cooling stages based on the sensing of transformer winding temperature. Each fan (and/or pump) shall be driven by an enclosed waterproof induction motor rated 240 volts AC, single phase, and 60-hertz. Each motor shall be equipped with thermal overload protection. Each fan (and/or pump) shall be dynamically balanced for vibration-free operation. All fan guards shall be stainless steel and shall meet OSHA safety standards.
- 8.8.7 Automatic control of all electrically powered cooling systems shall be accomplished by the closure of contacts within a thermally operated winding temperature relay. The first set of contacts shall initiate the first stage of cooling. The second set of contacts shall initiate the second stage of cooling. A third set of contacts shall be wired to a control cabinet terminal block for use by the Commission for tripping.
- 8.8.8 The cooling systems shall provide a control switch for the transfer of cooling operation from automatic to manual control. All cooling system controls shall be enclosed in the transformer control cabinet, complete with all conduit and inner wiring to the fans.

8.9 Current Transformers (CT)

- 8.9.1 Provisions shall be made in the power transformer for installing bushing-type current transformers mounted inside the main case on terminals H1, H2, H3, X1, X2, X3, and X0 with leads brought to identified terminals in a control cabinet. Current transformers will be sourced from USA headquartered companies only and have copper windings. Terminal blocks shall have short-circuiting devices which will allow a continuous CT secondary circuit while CT tap positions are being changed. Each CT shall be connected to a separate six-point terminal block. Terminal designations shall comply with the attached drawings designated Appendix 1.
- 8.9.2 Current transformers (CT) to be furnished on terminals shall be as follows:
 - a. Provide six (6) 600/5 ampere, with standard BCT multi-ratio, 5 leads, C800 relaying accuracy current transformer, two (2) each on H1, H2 and H3 with taps for 50, 100, 150, 200, 250, 300, 400, 450, 500, and 600 to 5 ampere ratios.
 - b. Provide one (1) 600/5 ampere, with standard BCT multi-ratio, 5 leads, C200 relaying accuracy current transformer in the neutral of the secondary (X0) with taps for 50, 100, 150, 200, 250, 300, 400, 450, 500, and 600 to 5 ampere ratios.
 - c. Provide six (6) 2000/5 ampere, with standard BCT multi-ratio, 5 leads, C800 relaying accuracy current transformers, two (2) each on X1, X2 and X3 with taps for 300, 400, 500, 800, 1100, 1200, 1500, 1600, and 2000 to 5 ampere ratios.

Appendix 1: A stainless steel metal CT diagram instruction plate shall be provided. Turns progression and accuracy class of bushing current transformers shall be shown on the nameplate.

8.10 Control Cabinet

- 8.10.1 A weatherproof painted stainless-steel control cabinet with 3-point latch shall be furnished enclosing control circuits, signal circuits, protective relays, individual transformer alarm indicators, interior lighting, convenience outlet, and a suitable 240-volt, 60 Hertz, heater with double-pole thermal circuit breaker. All wire into the control cabinet shall have 600-volt, flame-resistant, moisture-proof insulation and shall be enclosed in metallic conduit. All control conductors shall be tinned copper. All control wires into the control cabinet shall terminate on clearly marked and properly identified terminal blocks. All wires shall be identified by showing the other end it came from and the landing designation. A swing out panel shall be provided to mount an SEL 2414 transformer monitor.
- 8.10.2 Terminal blocks for CT leads shall be shorting-type and each CT shall be connected to a separate six-point terminal block. All the secondary leads of the current transformers shall be extended to shorting type terminal blocks (GE EB-27 or equivalent) in the control cabinet. CT wiring shall be No. 10 AWG minimum and be terminated with insulated ring lugs.
- 8.10.3 The weatherproof control panel shall be centrally located in Segment 1 per IEEE C57.12.10 near the bottom of the tank at a location to be approved by the Commission. The cabinet door shall be completely weatherproof and shall have a handle with triple latching mechanism, hinged on the left side. Handle/latch mechanism shall be furnished with padlocking provisions. Bolted door covers will not be acceptable. Window shall be UV protected safety glass.
- 8.10.4 A dead-front control panel in the control cabinet shall contain the necessary switches, circuit breakers, relays, indicating lamps, etc. Target relays or indicating lamps shall be visible through an UV protected safety glass window in the front door of the cabinet.
- 8.10.5 The control cabinet heater shall be equipped with guards and thermostatically controlled so that the guard temperature cannot exceed 120°F. The 240-volt electric terminals of the heater shall also be covered.
- 8.10.6 All cabinets attached to the transformer shall be solidly grounded to the transformer case.
- 8.10.7 Conduit entrance provisions shall be provided in the bottom of the cabinet.

8.11 Wiring

8.11.1 All power wiring shall be made with #12 AWG stranded tinned copper wire or larger sized wire. The primary insulation jacket of all wiring shall be 600 volt, 105°C, water, oil, and flame resistant. Control wiring shall be 45 or 65 mil stranded cable and not smaller in size than #14 AWG tinned copper wire, with the exception that wiring to alarm auxiliary relays and indicating lights may be smaller in size. SIS control wire is recommended. All current transformer leads are to be #10 AWG stranded tinned copper.

- a. Power wiring shall be sized as required in accordance with the National Electrical Code.
- b. All connections for wiring shall be made using silicon bronze, split-type lock-washers.
- c. All wires shall be identified at each end with legible permanent labels. Wire identification shall show both placement and where it came from.
- d. Wiring connections between fixed and hinged sections shall be minimum 41-stranded wire.
- e. Seven-stranded control wire is not acceptable.
- f. All terminal connections for conductor sizes #10 AWG in size and smaller shall be made with pre-insulated, full-ring tongue, crimp-type lugs. Lugs shall be AMP, Inc., "Pre-Insulated Diamond-Grip" (PIDG) with nylon or PVC sleeves or approved equivalent. Spade-type terminals or slip-on connectors are not acceptable.
- g. All terminal connections for conductor sizes #2 AWG through #9 AWG shall be made with Burndy Insulug Type YAEV or approved equivalent.
- h. All terminal connections for conductor sizes larger than #2 AWG shall be made with two-hole, long-barrel, double-indent, crimp-type lugs: Burndy Hylug Type YA or approved equivalent. (Single-hole lugs may be used only where necessary).

8.11.2 Grommets shall be provided for all openings in metal barriers used for wiring.

8.11.3 Un-insulated exposed conductor or terminal lug shall not extend beyond the sides of the terminal block or its insulating barriers.

8.11.4 All leads for multi-ratio current transformers shall be wired to terminal blocks in the control cabinet. If junction boxes are required in wiring between current transformer and control cabinet, terminal blocks shall be used for wiring connections. In-line-type disconnecting terminals such as American Petroleum Institute (API) No. 32488 or Burndy No. YZ10 will not be acceptable.

April 2022

S-13

8.11.5 If accidental short circuiting of certain wires can result in malfunction of equipment, these wires shall not be terminated on adjacent terminal block points.

8.11.6 Two (2) wires per terminal point maximum are permissible with opposite lay of terminal lug.

8.12 Terminal Blocks and Fuse-holders

8.12.1 Molded-type terminal blocks, rated 600 volts and 30 amperes, for all external control connections shall be provided. Terminal blocks with self-contained pressure-type connectors are not acceptable.

8.12.2 Marathon 1600 DJ series of Buchanan or equivalent Type HD or XHD terminal blocks shall be provided furnished with white marking strips for identification of terminal wires for all connections except current transformers. The terminals shall be identified with legible permanent markings.

8.12.3 Marathon 1600 SC series terminal blocks or equivalent shall be provided for current transformer leads with at least three shorting screws per terminal block. A separate short-circuit-type terminal block shall be provided for each set of current transformer leads. A States terminal block is not an acceptable substitution.

8.12.4 One three-pole terminal block sized for #6 to #2/0 AWG wire for Commission's single-phase, three-wire, 120/240 volt; control power leads shall be furnished.

8.12.5 A minimum of fifteen percent (15%) spare (but not less than 12 points) terminal points shall be provided in the control cabinet. These terminal points shall be furnished with all screws and lock-washers.

8.12.6 Circuit breakers shall be ABB or Square D Industrial series (non-residential) and philips/straight-slotted silicon bronze screws on each terminal, or approved equivalent.

8.13 Alarms and Relays

8.13.1 The transformer shall be equipped with various alarms wired to an SEL-2414 transformer monitor to provide indication of abnormal conditions as designated herein. Each alarm shall be in the form of a normally open contact wired to the SEL 2414 via terminal blocks in the transformer control cabinet via paired wire leads. The SEL 2414 shall be flush-mounted on the swing panel within the transformer control cabinet. The model number of the SEL 2414 shall be 241422CCC9XCC3C1431 Key Code 1116.

- 8.13.2 The following alarms are to be wired to the SEL 2414:
- a. Transformer Sudden Pressure (63FP)
 - b. Transformer Liquid Level - Main Tank (71Q)
 - c. Transformer Liquid Level - LTC (71 QLTC)
 - d. Transformer Pressure Relief (63PR)
 - e. Transformer Under-Voltage (auxiliary power) (27-1)
 - f. Transformer Fan Failure (49-88F)
 - g. Transformer Gas System - High Pressure (63G-HI)
 - h. Transformer Gas System - Low Pressure (63G-LO)
 - i. Transformer Gas System (63G)
 - j. LTC Raise Limit (33R)
 - k. LTC Lower Limit (33L)

8.14 Fault Pressure Relay

A fault pressure relay shall be provided and installed on the transformer and will be independently connected to the station "lock-out" relay. The fault pressure relay is to be provided with a pair of normally open, isolated contacts for tripping and alarms complete with all auxiliary relays necessary to make it capable of activating the substation protection scheme as well as alarming this condition. Fault pressure relay shall be complete with auxiliary hand reset and target relay similar Qualitrol 909-300-01 or equal to General Electric Type HAA-16B. The sudden pressure relay shall be Qualitrol Series 900 or 910 with auxiliary relays as required. The fault pressure relay shall be located on the transformer to avoid false tripping during through-fault conditions. The fault pressure relay shall be located on the side of the transformer tank to permit testing without removing the unit from service. Relay shall be accessible from ground level.

8.15 Oil and Winding Temperature Measurement

- 8.15.1 Visual indication of transformer top oil temperature and winding temperature shall be provided by a SEL 2414 transformer monitoring system. The monitoring system shall be provided with 100 Ohm platinum resistance temperature detector (RTD) and winding temperature current transformer per IEEE standards. In lieu of a thermal sensing bulb and capillary tube, the RTD shall be installed in the thermal well located in the hottest oil near the top of the transformer tank.
- 8.15.2 The SEL 2414 transformer monitoring system shall provide a local display of the transformer top oil temperature and the simulated winding temperature. The top oil temperature display shall be capable of measuring and displaying a range of 0° to 120° Celsius in 1° increments. The winding temperature display shall be capable of measuring and displaying a range of 0° to 180° Celsius in 1° increments.
- 8.15.3 The SEL 2414 transformer monitoring system shall provide all relays necessary to automatically actuate first and second stage auxiliary cooling, based upon measurement of the winding temperature.

- 8.15.4 The power supply for the SEL 2414 transformer monitoring system shall be configured for 48 VDC input to maintain stability of the temperature data during ac power system disturbances.
- 8.15.5 The SEL 2414 transformer monitoring system shall be completely installed as an integral component of the power transformer.

8.16 Surge Arresters

- 8.16.1 Surge arresters shall be of the station-class-type, transformer-mounted for the high and low voltage side on each phase of the three-phase transformer.

The arresters rating shall be:

System Voltage	Conventional Arrester Rating	Metal Oxide MCOV Arrester Rating
67 kV, 350 kV BIL	72 kV	57 kV
13.09/7.56kV, 110 kV BIL	10 kV	8.4 kV

- 8.16.2 Metal oxide surge arresters are rated either in terms of maximum continuous operating voltage (MCOV) or by the conventional arrester rating which they replace. MCOV ratings are assumed here for metal oxide arresters. However, metal oxide arresters which are given conventional ratings may be furnished if the MCOV equivalent ratings are as specified here.
- 8.16.3 The surge arresters shall be located with relation to one another and the bushings to comply with, or exceed, minimum phase-to-phase and phase-to-ground clearances between live parts in accordance with Appendix 3.
- 8.16.4 The surge arresters shall be provided with connections to the line-side bushing terminals with connections equivalent to double 500 kcmil copper minimum. Ground conductors equivalent at minimum to 4" x 1/4" copper bus shall also be furnished and carried to the transformer ground pads with loop configuration as shown on Drawing Appendix 2. The copper shall be tinned at all connection points and the copper bar shall be paint with ANSI Gray 70 paint.
- 8.16.5 The body of the surge arresters shall be wet-process porcelain, light gray, ANSI No. 70.
- 8.16.6 The surge arresters shall comply with IEEE Standard C62.1. Arrester spark-over* and discharge voltages shall not be greater than:

* Or equivalent ANSI or IEEE parameter for metal-oxide arresters.

8.17 Positive Pressure System

8.17.1 The transformer shall be equipped with a positive pressurizing system utilizing nitrogen gas to protect the transformer oil in the main tank from oxidation and moisture absorption. The system shall consist of a nitrogen gas supply (cylinder) complete with supply pressure gauge, multi-stage pressure reduction assembly, and associated piping and valves to control the flow of gas to and from the tank. The system shall provide alarms for low gas supply, high tank pressure, and low tank pressure conditions. The nitrogen supply cylinder, supply pressure gauge, and multi-stage pressure reduction assembly shall be housed in a weatherproof enclosure.

8.17.2 The system shall maintain transformer tank pressure at 0.5 psi minimum and 5.0 psi maximum, with appropriate fill and bleed-off regulation. Gas system alarms shall actuate whenever pressure falls below 0.5 psi or rises above 5.5 psi or whenever supply pressure falls below 100 psi.

8.18 Transformer Oil Inhibitor

All oil is to be Type II insulating transformer oil supplied shall have antioxidant oil inhibitor added. The manufacturer may supply 0.3% wt. DBPC or 0.3% wt. DBP inhibitor. Installation of inhibitor shall be in accordance with newest version of IEEE C57.106.

8.19 Load Tap Changing for Transformer

8.19.1 The transformer to be furnished shall be provided with a Reinhausen Type RMV-II on-load tap changing unit equipment in addition to all provisions described heretofore for all. Be reactive vacuum with all arcing during tap change occurs in vacuum bottle. This requires a reactor for bridging taps during tap changer operation. The tap changing equipment for the transformer must be capable of parallel operation with a second LTC-equipped transformer. Method of parallel operation to be in accordance with IEEE C57.15 standard circulating current method or as agreed to by the Owner.

8.19.2 The load tap changing equipment shall be furnished to provide the characteristics and features outlined herein. The equipment shall be designed to withstand full-voltage short-circuit conditions and also to initiate and complete any desired tap change under full-voltage short-circuit conditions. The manufacturer, if it so desires, may submit an alternate Proposal for vacuum switching. The manufacturer will state in its Proposal the guaranteed minimum number of maintenance-free LTC operations of the unit. Units guaranteeing less than 500,000 operations before maintenance will be evaluated as unresponsive.

8.19.3 The load tap changing equipment covered by the Technical Specifications and all tests applied thereto shall conform to the latest standards of the IEEE, NEMA, NESC, and ANSI.

- 8.19.4 The LTC circuit and components shall be arranged so that with a constant voltage held on any high voltage rated kVA tap, the tap changer will operate to provide \pm voltage regulation of the low-voltage transformer terminals in sixteen (16) 5/8% steps above and below rated voltage. For voltages above rated position, the transformer will deliver rated kVA. For voltages below rated position, the transformer will deliver at its terminals a current equal to the current at rated kVA and rated voltage.
- 8.19.5 The LTC taps may be located wherever necessary in the windings or circuits to produce the desired result. A series transformer may be used if necessary. However, the physical location of the load tap changing compartment must provide an unobstructed view of the LTC position indicator to any operator attending the main control compartment. The final location of the LTC compartment shall be subject to the approval of the Owner or the Owner's Engineer. Provision for manual operation with electrical interlock with drive motor must be used.
- 8.19.6 The main transformer tank shall include:
- a. Series transformer (if required by design).
 - b. Preventive reactor.
 - c. Current transformer for line-drop compensator. Primary current determined by rating and design. Secondary current 0.2 amps.
 - d. Hot spot temperature indicator.
- 8.19.7 The separate oil-filled compartment shall include:
- a. Tap selector switch and contactor mechanism, with reversing or transfer switch.
 - b. Mechanical stops at limits of switch movement.
 - c. LTC Compartment breather will be a Qualitrol STB000 LTC Smart Transformer Dehydrating Breather.
 - d. Liquid-level gauge similar to gauge used on transformer tanks.
 - e. Drain and filling valve: one-inch (1") screw-end globe valve.
- 8.19.8 The separate air-filled compartment shall include:
- a. Microprocessor control equipment, including:
 1. Voltage-level circuit adjustment
 2. Bandwidth circuit adjustment
 3. Time-delay circuit adjustment
 4. Line-drop compensator with resistance and reactance adjustment
 5. Reactance reversing switch
 6. Band-edge test lights and switch
 7. Potential circuit breaker
 8. Output-voltage test terminals
 9. Potential supply input terminals and disconnect switch
 10. Space for mounting individual parallel switch for parallel operation

- b. Motor control equipment, including:
1. Drive motor 240 volts single-phase to be supplied from station power supply.
 2. Provision for manual operation with electrical interlock with drive motor.
 3. Automatic-manual switch with raise and lower.
 4. Position indicator equipped with electrically resettable drag hands and with electrical limit switches. The position indicator shall be graduated for each step position (16L-0-16R), and shall be located for unobstructed visibility to any personnel attending the main control compartment of the transformer.
 5. The electrical limit switches shall be interconnected to the motor control circuit for automatic cutoff at the end of the raise and lower tap range. The limit switch at either end of the range shall also provide one spare normally-open contact for annunciation of end-of-range LTC position.
 6. Neutral indicator LED lamp.
 7. Motor drive power-supply switch with thermal breaker.
 8. Operation counter.
 9. Lamp with manual switch for compartment illumination.
 10. Convenience outlet.
 11. Strip heater.
 12. Terminal blocks for customer connection.
 13. Conduit entrance in bottom of compartment.
 14. Current transformers for parallel operation.
 15. Voltage control circuitry and circulating current protection for automatic parallel operation of two (2) units on the same substation bus. Circulating current CT's shall be provided in the line-drop compensator circuit to permit this and other similar units at this location to operate in parallel automatically with minimum circulating current.
 16. Necessary terminal blocks and wiring.

8.19.9 Remote LTC Control - The load tap changer shall be quoted including the installation of equipment for remote operation and indication by a supervisory system. The necessary contacts and/or devices shall be included to provide the following functions or indications:

- a. Indication of maximum raise and lower positions as an alarm condition to the supervisory system.
- b. Integrity control failure alarm (vacuum unit only).
- c. Vacuum contact failure alarm (vacuum unit only).
- d. Three-step automatic voltage reduction control with steps at three percent (3%), five percent (5%), and seven percent (7%), controlled by supervisory system.

- e. Remote position indicator for monitoring tap changer position in the substation control house. This device shall be a Selsyn® type telemetry providing a rotary position between the transmitter and receiver, such as; an Incon 1292 Synchro-transmitter and an Incon 1250 Tap Position monitor. The position of the shaft shall not be lost or reset each time power is applied. Remote indicator shall be analog, a digital monitor will be considered less responsive. The transmitter unit shall be installed and connected to the tap changer operating shaft.
- f. Provisions for the selection of local or remote operation of the tap changer motor circuit. The circuitry shall be designed so that the "remote" operating mode will override local automatic LTC operation and enable remote raise and lower commands as described below. Selection of the "local" mode at the LTC control will override any position selected at the remote location.
- g. Provisions for the remote initiation of "raise" or "lower" commands to the LTC control. The circuitry shall be designed so as to allow remote raise and lower only when the LTC control is set for remote control.
- h. Provisions for the connection of a remote indicator LED lamp to annunciate the position of the local/remote switch in the "remote" position through the SEL transformer monitor.
- i. Provisions for the connection of a remote indicator LED lamp to annunciate the actuation of the LTC motor contactor pick-up for each tap change during remote operation through the SEL 2414 transformer monitor.

8.20 Special Control Requirement

8.20.1 Voltage regulation control of the LTC shall be provided, including voltage regulation and compensation module, LTC paralleling module, circulating overcurrent protection module, and overvoltage protection module. Modules shall be manufactured by Beckwith Electric Company and shall consist of:

M-2001D Tap Changer Control (w/Ethernet fiber ports)
M-0115A Parallel Balance Module
M-0127 AC Current Relay
M-0169 Auxiliary CT
M-0329 Backup Relay
Incon 1292 Synchro-Transmitter

8.20.2 The manufacturer must clearly indicate on the Form of Exceptions any substitutions to the Beckwith equipment. Should the manufacturer elect to substitute alternate controls, one (1) spare of each substitute module must be included in the base bid.

8.20.3 The control panel shall be of unit construction to allow its removal from the LTC control cabinet by disconnecting of polarized disconnect jack plugs.

8.20.4 The voltage regulating relay shall be capable of no-load voltage settings between 100 and 135 volts inclusive, having a ratio of 120-to-1 potential transformer secondary on a phase-to-neutral basis.

8.20.5 The bandwidth adjustment shall be capable of holding a regulated voltage bandwidth from plus or minus 1.5 volts to plus or minus 3 volts. A bandwidth indicating meter shall be furnished which provides an indication as to whether the input panel voltage is within the bandwidth.

8.20.6 Line-drop compensation shall have a minimum of 0-24 volts each for resistance and reactance. Test terminals for load and voltage shall be located for convenient testing. The time delay relay shall be capable of settings between ten (10) and ninety (90) seconds inclusive. All leads to the control shall be either color-coded or labeled for easy identification.

8.20.7 The control shall be equipped with an accessory that limits the maximum voltage or minimum voltage output. This accessory shall be adjustable from 120 to 135 volts maximum and 105 to 120 volts minimum.

8.20.8 All control modules shall have DNP 3.0 protocol and fiber optic ports.

8.21 Current Transformers

The current transformer ratio for line-drop compensation shall be noted in the proposal.

8.22 Potential Transformers

Sensing voltage for the LTC control panel will be supplied by an Owner-furnished externally mounted potential transformer having a line-to-neutral voltage ratio of 60:1. The materialman will provide terminal block provision for the two-wire external leads from external PT to be landed for sensing voltage.

9.0 Additional Features

The transformer shall include but is not limited to the following mechanical and electrical features:

- 9.1 Two (2) NEMA 2-hole ground pads per IEEE C57.12-17.99 or latest version for connectors for 4/0 through 500 kcmil stranded copper conductor.
- 9.2 Main transformer core ground shall be accessible from ground level.
- 9.3 6-inch dial face liquid-level gauge with alarm and trip contacts and liquid temperature indicator, compatible with the SEL 2414.
- 9.4 Qualitrol 104 SCADA Capillary Based oil liquid temperature indicator model, compatible with the SEL 2414.
- 9.5 Pressure vacuum gauge and bleeder device such as Qualitrol 070 Series with sampling and purging valve. Gauge shall be mounted at eye level.
- 9.6 Qualitrol XPRD pressure relief device with alarm contacts and 8" aluminum discharge pipe, compatible with the SEL 2414.
- 9.7 Upper valve for filter-press connection and a filling connection, both one inch (1").

- 9.8 Lower valve for combination filter-press connection, two-inch (2"), with 3/8" oil drain and sampling device and vacuum fittings.
- 9.9 Pressure Vacuum Bleeder
- 9.10 Manhole (eighteen inches (18") diameter minimum) and, if required, one or more hand holes (eight inches (8") diameter minimum).
- 9.11 Lifting lugs on tank capable of lifting the entire transformer completely assembled, lifting eyes on cover, and provisions for jacking. Location of jack bosses shall be a minimum of thirteen inches (13") above the transformer base line and capable of supporting entire weight of transformer completely assembled.
- 9.12 Stainless steel nameplate in accordance with ANSI Standards, located on the main tank near the control cabinet.
- 9.13 Metal diagram instruction plate shall be stainless steel. Turn progression and accuracy class of bushing current transformers shall be shown on nameplate.
- 9.14 Lightning Arrester Mounting. Tank mounted lightning arrester brackets shall be provided as follows: Three (3) removable tank mounted brackets for mounting the specified station class arresters near each high voltage bushing. Three (3) brackets for mounting the specified low side arresters near each low voltage bushing.
- 9.15 Support brackets, conductor, and connectors for the transformer grounding system, as outlined in paragraph 8.16.4 and as shown on Drawing Appendix 2.
- 9.16 Under-Voltage relay for all phases of cooling power.
- 9.17 All valves shall have silicone rubber (or better) packing to prevent leaking.
- 9.18 No tripping relays shall be mounted on a swinging panel. All tripping relays shall have covers.
- 9.19 Insulating oil with associated PCB certification and nameplate, per General Conditions.
- 9.20 Forced-air cooling fans shall be single phase, 60 Hertz, 240 volts with stainless steel OSHA guards.
- 9.21 Three (3) 600:5 multi-ratio current transformers of C800 relaying accuracy on each high-voltage phase bushing with leads brought down to shorting terminal blocks in control cabinet.
- 9.22 One (1) 600:5 multi-ratio current transformer of C200 relaying accuracy on the neutral low-side bushing, with leads brought down to shorting terminal blocks in control cabinet.
- 9.23 Six (6) 2000:5 multi-ratio current transformers of C800 relay accuracy on each low-voltage phase bushing with leads brought down to shorting terminal blocks in control cabinet.
- 9.24 Fault pressure relay with leads and auxiliary relays as specified.

- 9.25 All alarm contacts shall be suitable for 48V DC with separate wiring from all terminals of each device to a terminal block located in the transformer control cabinet and shall be compatible with the SEL 2414. All control wiring and CT terminals to be equipped with non-magnetic split-type lock washers and ring-type compression lugs. All current transformer leads to be #12 or larger and terminated on separate six-point shorting-type terminal blocks in the control cabinet.
- 9.26 Each cooler (removable radiator) shall be provided with drain and vent plugs connected at top and bottom and valves for detachable radiators, coolers, and/or pumps.
- 9.27 All equipment required for positive pressure gas regulation system, including alarms.
- 9.28 Tap changer instruction nameplate, stainless steel.
- 9.29 Core ground pocket bushing with protective cover shall be accessible from the ground.
- 9.30 Install Vaisala Model OPT100-OPTIMUS A1A3N0N0N0B1N0N0N1A0 DGA gas monitor wired to transformer control cabinet connected to a SEL 2414 using DNP. A CAT6 Ethernet cable between the Vaisala OPT100 and the main control cabinet. Mounting to include isolating valves and galvanized materials are not permitted. **Materialmen must purchase the field commissioning of the OPT100.**
- 9.31 Fall-Arrest System – provide DBI SALA 8516691 Portable Fall Arrest System and 8517565 Carrying/Storage bag. Manufacture will weld bare steel plate DBI SALA Model 8517412 and then paint to match transformer ANSI 70 Gray.

<http://www.aikencolon.com/dbi-sala-8516691-advanced-portable-fall-arrest-post-system#3>

10.0 Tests

- 10.1 Transformer shall receive standard commercial tests in accordance with ANSI/IEEE Standards.
- 10.2 Transformer shall receive standard ANSI/IEEE impulse tests, including full wave and chopped wave on each high-voltage line terminal and on each low-voltage line terminal. Copies of oscillography and a formal report will be submitted as a record of the tests.
- 10.3 Transformer shall receive a Sweep Frequency Response Analysis (SFRA) during factory testing on the neutral taps. Frequency of 15, 30, 45, 60, 145, 230, 315, and 400 Hertz shall be used. This test shall be repeated during site testing. Results shall be compared and a report provided with explanation for any differences in results.
- 10.4 The loss measurement system used to measure losses shall state in the test report the measurement error traceable to the National Bureau of Standards (NBS) by means of a procedure described in NBS Technical Note 1204 or an approved equivalent procedure. This shall be applicable to the test system used to measure both the no-

load and load losses for the transformers specified herein. The approach outlined in NBS Technical Note 1204 or an approved equivalent procedure shall be used to insure the traceability of measurements. The measurement error determined through the procedure outlined in Technical Note 1204 or an equivalent procedure will be added to the measured losses determined during the test prior to the determining if the loss guarantee has been met. Should the Bidder (manufacturer) be unable to comply with this provision, it shall clearly so state in the section entitled "Form of Exceptions".

- 10.5 All transformer losses, including auxiliary losses, shall be shown on the test reports.
- 10.6 In addition to the standard ANSI/IEEE tests, the Commission shall select one of the following corona tests:
 - a. First, the transformers shall be corona-tested at the full induced test-voltage level. Equipment and general method used will be in accordance with IEEE Transformer Committee Report: IEEE Transactions PAS 86 No. 12, December 1967, "Tests for Damaging Corona on Oil-Insulated Power Transformers."
 - b. Second, the corona test shall be made after all other insulation tests are completed. The RIV readings shall not exceed one hundred (100) microvolts for the following test procedure:
 - c. The corona tests shall be made as follows: one with the cooling oil-circulation pumps shut down and one with all pumps running. Only one (1) corona test will be required where no pumps are required for cooling.
 - d. For each test, RIV readings at one hundred seventy percent (170%) of rated maximum voltage to the transformer terminal shall be recorded for at least five (5) seconds, after which the test voltage should be reduced to one hundred fifty percent (150%) of rated maximum voltage and held for one (1) hour. Should the corona RIV reading increase in the last twenty (20) minutes of the test, the test-time shall be extended beyond one (1) hour to allow time for the RIV readings to stabilize or decrease. If the RIV readings continue to increase, the test shall be considered to indicate a transformer failure. Further investigation shall be made to determine the problem and to correct it.
 - e. Corona shall be monitored continuously throughout the test and recorded every five (5) minutes. This shall be made a part of the certified test reports. A frequency of 120 Hertz is recommended for each test.
- 10.7 The Materialman shall clearly state any exceptions of lack of capability to perform either of the above corona tests.
- 10.8 Insulation power factor tests shall be made and shall be one percent (1%) or less corrected to 20°C by the IEEE temperature correction curve.
- 10.9 Prior to shipment, the assembled transformer shall be liquid-filled and pressure-tested for at least eight (8) hours at the maximum operating pressure for detecting the presence of leaks.

- 10.11 The transformer sound level shall be tested in accordance with NEMA TRI-9.04, "Audible Sound Level Tests."
- 10.12 No transformer will be accepted for shipment until approved by the Commission or the Commission's Engineer.
- 10.13 The Commission reserves the option of having a representative witness any or all tests.
- 10.14 All impedances between windings shall be shown on the test reports.
- 10.15 The manufacturer's field engineer or hired testing firm shall perform a series of tests on the transformer after installation at the substation. These tests shall include Sweep Frequency Response Analysis, transformer turns ratio tests for all tap positions, insulation Megger tests, current transformer checks (polarity, turns ratio, and connections), and oil tests as follows: specific gravity, dielectric, moisture content, acidity, interfacial tension, and PCB content. The manufacturer shall provide a complete dissolved gas in oil analysis on the oil installed in the transformer after final assembly. Directions for collection of the samples and the recording of temperature of oil at time of collection and shipping containers shall come with the bombs. The manufacturer shall conduct a complete DGA on each sample and send the results to the Commission engineer or designated person. Each Sample shall be tested for specific gravity, moisture content, acidity, and interfacial tension.
- 10.16 The manufacturer's field engineer shall give approval for energizing the transformer, and a manufacturer's representative shall be on site to observe the entire energization process.
- 10.17 The transformer core ground strap is to be made accessible from ground level so that it may be removed when making the core ground tests. Tests for core grounds are to be performed after tanking and just prior to leaving the factory using a 1000-volt Megger. Resistances measured are to be included in a certified test report and reported to the Engineer prior to shipment. The Bidder may offer in its quotation deductions for substitution of manufacturers' standard tests in lieu of those specified. However, the basic quotation must include all tests specified.
- 10.18 The Commission reserves the option of having a representative present to inspect the core and coils prior to tanking and to witness any or all tests.
- 10.19 Without limiting in any way any obligation of the Bidder under this agreement, the Bidder shall demonstrate to the satisfaction of the Commission that the transformer proposed to be furnished under the Technical Specifications shall have sufficient mechanical strength to withstand without failure all fault currents. The Bidder shall demonstrate that the transformers meet this requirement by one of the following methods:
 - 10.19.1 Certified test data showing that a transformer with a core and coil identical in design and construction and identical or similar with respect to kVA capacity, kV ratings, BIL, losses, impedance and voltage taps has been tested without failure for short-circuit strength. A description of the test code under which the transformer was tested for short-circuit strength will be provided by the Bidder to the Commission.

- 10.19.2 A history of successful experience with transformers of identical or similar ratings, design, and construction. The Bidder shall list all transformers in service with core and coils which are essentially identical in design, construction, and manufacture to the transformer covered by this specification and provide information on the date of installation, location, and failures, if any. Where such transformers have not been built or the cumulative service record is less than twenty (20) transformer years, a list of transformers in service which represent the closest approximation to the transformer covered by this specification shall be submitted. The information submitted shall be representative of the total experience of the manufacturer with the design of the transformer it proposes to furnish and shall include the dates of installation or shipping, the ratings of the transformers, and the failures and causes of failure, if any have been experienced.
- 10.19.3 The Bidder shall submit with its Proposal a complete listing of all full-size transformers of its manufacture, in ratings 12,000 through 50,000 kVA, which have been short-circuit tested. The list shall include all full-size units tested, whether they were development tests or tests of customer units. Complete ratings shall be given of each unit and each shall be noted as to whether copper or aluminum windings were used for comparison with that winding material offered on this bid. In addition, if an OLTC was installed.
- 10.19.4 In the case of units tested for or by the ultimate customer, indication shall be given on each unit as to whether the test was successful or unsuccessful and, if tested more than once, each subsequent test shall be so listed and appropriate comments given as to design changes made, if any.
- 10.20 If the Bidder cannot furnish such test data, it shall so state on the Proposal.

11.0 Guarantees

Included with the transformer data to be submitted by the Materialman with its Proposal shall be the following:

- 11.1 Efficiencies at 1/4, 1/2, 3/4, and full load at unity power factor and 75°C.
- 11.2 No-load loss in watts. (Include losses at 1-raise and the average of 15-raise and 16-raise)
- 11.3 Total full-load loss in watts at each rating and temperature rise, plus auxiliary losses (shown separately), at:

Schedule No. 1

24,000 kVA	_____ Watts @ 55°C ONAN
26,800 kVA	_____ Watts @ 65°C ONAN
32,000 kVA	_____ Watts @ 55°C ONAN/ONAF
35,800 kVA	_____ Watts @ 65°C ONAN/ONAF
40,000 kVA	_____ Watts @ 55°C ONAN/ONAF/ ONAF
42,800 kVA	_____ Watts @ 65°C ONAN/ONAF/ ONAF

Include losses at 1-raise and the average of 15-raise and 16- raise

S - 26

- 11.4 Full-load regulation at one hundred percent (100%) and eighty percent (80%) power factor.
- 11.5 Exciting current at rated frequency in percentage of the rated voltage and rated kVA.
- 11.6 Cooling fans and pumps, H.P. rating, and voltage. 11.7 Net weight of transformer, including insulating oil. 11.8 Shipping weight of transformer.
- 11.9 Gallons of oil required per transformer.
- 11.10 Limiting dimensions of transformer.
- 11.11 Copies of the transformer test reports shall be furnished to the Commission at the time the transformers are shipped.
- 11.12 All oil-filled materials and equipment shall be certified in writing and by permanently-affixed nameplates to have a non-detectable level of PCB dielectrics, i.e., less than 2 ppm, in compliance with Federal Register (44FR31514), May 31, 1979.

12.0 Transformer Bid Evaluation

Bids submitted shall be evaluated for "Equivalent First Cost" utilizing initial cost, transformer losses, and the cost of financing over a twenty-year (20-year) evaluation of ownership. The formalization is as follows:

$$\text{"Equivalent First Cost"} = (\text{Unit Cost*}) + (\text{No-Load Losses} \times A) + (\text{Winding Losses} \times B)$$

*Including any, cost of insurance (1) if less than a five-year warranty is quoted, or other adjustments to quoted prices are necessary to evaluate equal offerings.

For the purpose of evaluating transformer losses for award and determination of compliance after manufacturing and testing, the following will apply for no-load and winding losses:

No-load and winding losses:

No-load losses will be evaluated using the average of quoted losses at LTC 1R position and LTC average 15R and 16R positions.

Winding losses will be evaluated using the quoted losses at LTC average 15R and 16R positions

The Cost of Losses will be evaluated using the following kW charge:

	<u>24MVA Base Rating</u>
No-Load Loss (A)	\$ 5,200 per kW
Winding Loss (B)	\$ 1,800 per kW

The Commission reserves the right to change at any time the no-load loss and winding loss charge values given above insofar as these values are used to evaluate bids. Such changes might be necessary to reflect changed conditions and are not expected to be more than $\pm 20\%$ of the values shown above. Nevertheless, liquidated damages as described below will be based on the values given above. If bids total cost evaluations are within five percent (5%) of each other at total cost of ownership the Commission reserves the right to go back to lowest cost transformer as the awarded bidder.

The no-load and winding losses quoted by the Bidder are of the essence of the Contract. Should the Materialman neglect, refuse, or fail to meet the quoted losses herein provided, the Commission shall have the right to deduct from and retain out of such monies which may be then due or which may become due and payable to the Materialman the sum equal to the difference in quoted loss values and the actual loss values as verified by the certified test reports provided after manufacture computed in dollars utilizing the no-load loss and winding loss values listed above as liquidated damages and not as a penalty. In no event shall the adjustment factor under this provision result in a net price increase to the Commission. If the amount due and to become due from the Commission to the Materialman is insufficient to pay in full any such liquidated damages, the Materialman shall pay to the Commission the amount necessary to affect such payment in full, provided, however, that the Commission shall promptly notify the Materialman in writing of the manner in which the amount retained, deducted, or claimed as liquidated damages was computed.

For the purpose of evaluation, those manufacturers who fail to provide prompt and thorough responses to installation or service problems will be assessed a penalty. This penalty will be assessed for present and future problems. It is in the best interest of the Commission to receive equipment which is placed into service easily and does not continue to experience service problems. The current adder for evaluation is five percent (5%), which will be added to the purchase price of those manufacturers, who in the exclusive opinion of the Commission have documented installation and service problems.

13.0 Transformer Accessories

The following accessories shall be installed in the location as specified in IEEE C57.12.10.

- Transformer shall be equipped with a weatherproof, hand-operated, tap changing mechanism suitable for de-energized operation of the high voltage taps.
- Removable without breaking tank seal dial-type winding temperature indicator with resettable drag hand and adjustable alarm and trip contacts.
- Removable dial-type liquid oil thermometer indicator with resettable drag hand and adjustable alarm and trip contacts.
- Removable dial type magnetic liquid level gage with alarm contacts.
- Cover-mounted mechanical pressure relief device with automatic resealing-resetting operation alarm contacts and mechanical signal for indication of device operation.
- Thermal plate for remote winding temperature and liquid temperature gages.
- Thermal current transformer located on the X2 bushing for winding temperature indicator.

- A diagrammatic nameplate per IEEE C57.12.00 which shall have a bar code giving the size, manufacturer's identification number, and the serial number.
- Base designed for rolling, provision for pulling in directions of center lines of each segment.

S-28

- Lifting lugs for lifting complete transformer.
- Jacking facilities at four corners of the base.
- Lifting eyes for cover only.
- Facilities for lifting core and coil assembly from tank.
- Two ground pads with tapped NEMA two-hole drilling for tank grounding located on diagonally opposite corners.
- Two manholes in the cover.
- The transformer core shall be grounded to the transformer tank. To facilitate testing of the core clamp insulation, the core ground shall be accessible through a 1.2 KV bushing located in a terminal box on the top of the tank cover or accessible from the ground.
- (3) Upper valve, 2" globe type.
- (2) Lower valve, 2" globe type.
- Main tank drain valve, 2" globe type with plug.
- Pressure vacuum bleeder for monitoring units shipped dry air.
- All gaskets shall be reusable nitrile rubber with means provided for controlled compression.
- Installed transformer shall be filled with ASTM Type II insulating transformer oil with an inhibitor per IEEE C57.106. All oil and inhibitor shall be furnished and installed by the manufacturer.
- A Sudden Pressure Relay a Qualitrol 900 oil fault pressure relay located at eye level flange connected on the side of the transformer tank to allow testing without having to take the unit out of service and the output shall be interconnected to the station "Lock-out relay". Seal in relay (QUALITROL 909-300) for latching alarm or trip signal is required.
- Install Vaisala Model OPT100-OPTIMUS A1A3N0N0N0B1N0N0N1A0 DGA gas monitor wired to transformer control cabinet connected to a SEL 2414 using DNP. Mounting to include isolating valves and galvanized materials are not permitted. A CAT6 Ethernet cable between the Vaisala OPT100 and the main control cabinet. Materialmen must purchase the field commissioning of the OPT100.

14.0 Transformer Control Cabinet and Wiring

The control cabinet shall be a NEMA 3R and suitable for outdoor use and shall be integrally mounted to the transformer tank and contain all control circuits, auxiliary relays and terminal Boards as required to provide a single interface location for all PWC field wiring to the transformer. The door hinge pins shall be stainless steel with a three-point latching system. All factory installed wiring shall be 600 volt and 105° C with stranded, tinned copper conductor. Control and alarm circuits and power circuits shall be #14 AWG and CT circuits shall be #12 AWG. All conductors shall be identified at point of termination and all wiring on the exterior shall be routed in galvanized electrical steel conduit fastened to tank using approved fittings. The control cabinet shall contain a thermostatically controlled heater of sufficient size to prevent condensation. The cabinet shall contain a duplex receptacle and interior light and be wired for 120/240 VAC, single-phase, 3-wire service. The bottom plate of the cabinet shall have a minimum clearance to the base of the transformer of sixteen inches (16") with a field drillable removable bottom plate.

15.0 Transformer Tank and Oil Preservation

The sealed steel tank shall be formed and fabricated with a welded cover supplied with an inorganic gasket permanently located between the cover and the tank flange to prevent entrance of weld splatter during welding. All welds shall meet or exceed the requirements of the American Welding Standards (AWS). The tank shall be designed and braced for full vacuum and shall be suitable for filling with oil under a vacuum. To maintain a positive pressure, the tank shall be an **Automatic Gas-Control Design** to maintain an atmosphere of dry nitrogen under a slight pressure between the top oil and the cover. The gas-control shall have a pressure gage, nitrogen low-pressure alarm switch, gas cylinder, regulator, and all associated control equipment.

Removable radiators mounted on the transformer shall be provided. A shut off valve shall be furnished at each radiator connection for isolating individual radiators with a double flanged valve. A drain connection and a filling connection shall be supplied on each individual radiator.

Cooling fans shall be single phase, 60 hertz, and 240 volts with standard stainless-steel guards to meet OSHA safety requirements. Fan blades shall be carefully balanced to keep sound levels to a minimum. Fans shall be furnished with watertight connections and have motors that are totally enclosed non-ventilated with automatic reset thermal protectors.

16.0 Transformer Winding and Core Construction

All transformer windings shall be copper with circular coil design and circular core and shall be suitably clamped and harnessed with mechanical means at the top and bottom to prevent shifting under short circuit conditions as specified in the standard IEEE C57.12.00 latest revision. The paper covered rectangular copper wire is to be oxygen-free copper rod and shall be extruded or drawn by a mold. Transformer winding leads shall be connected to porcelain apparatus bushings using cable connections or bare copper bars with flexible links.

All core steel shall be low loss grain oriented electrical steels that come from the following approved companies: AK Steel – USA, or ThyssenKrupp Steel. Transformer core and windings shall be suitably harnessed in the tank to prevent movement during faults, shipping or installation. The installed core and coil assembly shall receive a Vapor Phase drying process to minimize moisture content.

Bid proposal shall describe the type of core and winding construction, including clamping design. Windings are to be copper in a circular coil, other designs, including rectangular core and coil design, will not be considered.

Solid insulation within the windings and clamping structure shall be of a high density Weidmann USA and/or ABB Pucaro transformer-board manufactured in accordance to IEC 60641-3 B.3.1.A.

Solid insulation within the windings and clamping structure shall be of a suitable cellulosic high density transformer-board supplied by a manufacturer with a proven history (15 or more years' experience supported by technical development and testing) and shall comply with current applicable industry standards for dielectric integrity, short circuit, thermal requirements, loss of life, and emergency loading.

Transformer-board will be produced using an electrical grade pulp specified by the transformer-board manufacturer.

Transformer-board to be produced using unbleached softwood Weidmann USA Kraft pulp with key properties and testing methods clearly specified by the transformer-board manufacturer.

Transformer is to be manufactured using only Weidmann USA and/or ABB Pucaro Transformer-board for solid, non-paper insulation components.

17.0 Transformer Paper Insulation for Conductor Insulation

Conductors shall be insulated with Weidmann USA 12HCC or 22HCC Crepe paper or M-250 flat paper thermally stabilized using the INSULDUR™ system. Solid insulation paper used to insulate the conductor between layers in the coil shall be thermally upgraded Kraft paper as defined by IEEE C57.100 as Cellulose based paper which has been chemically modified to reduce the rate at which the paper decomposed. Values for nitrogen content of acceptable thermally upgraded papers shall be between 1 and 4 percent (1-4%) when measured in accordance with ASTM D-982. Paper is to be supplied by a paper manufacturer from the **United States or Canada** with a proven record of no less than fifteen (15) years supplying this material for this application to be oil-filled, transformer industry.

18.0 Factory Tests:

The transformer shall receive at the factory those tests identified in IEEE Standard C57.12.00 latest revision section on "Routine Tests". All tests are to be performed at 60 hertz.

The transformer shall be designed and built to meet the short-circuit design requirements of IEEE C57.12.00 latest revision and the Short-circuit test code of IEEE C57.12.90 latest revision.

PWC shall be notified two (2) weeks in advance so that its representative can witness the following factory routine tests without causing any delays in factory schedules:

Preliminary Tests

- Ratio, Polarity and phase relationship
- Winding capacitance and Insulation dissipation factors
- CT polarity check and Hi-Pot in cover assembly
- Winding and core insulation resistance

Final Tests

- Oil test -PCB
- Particle count
- Moisture content
- Gas in oil analysis before final tests
- Total gas content
- IEEE 1816 Dielectric breakdown- BS-5874@1.0mm Gap
- Core insulation resistance
- Winding insulation resistance
- Winding capacitance and Insulation Dissipation Factors - Insulation P. F. = 0.4% (ANSI)
- Resistances per phase in ohms at 75°C.
- No load loss and exciting current after demagnetization -Repeat after impulse tests
- Operational test on LTC at 110% of operating voltage at No load-Chart required
- Lightning Impulse
- Applied Potential- HV and LV for 1 minute
- Induced Potential
- Guaranteed maximum μV , (RIV) < 10
- Gas in oil analysis -two samples
- Load Loss and Impedance
- Operational test on LTC at maximum current of maximum rating with Chart
- Winding capacitance and Insulation Power Factors - Doble- <0.4%
- Power Factor (Doble) excitation at 1L, N, 1R-+ 16R
- Measure losses of fans
- Sweep Frequency Response Analysis (SFRA) during factory testing on the neutral taps. Frequency of 15, 30, 45, 60, 145, 230, 315, and 400 Hertz shall be used.

Appendix 1

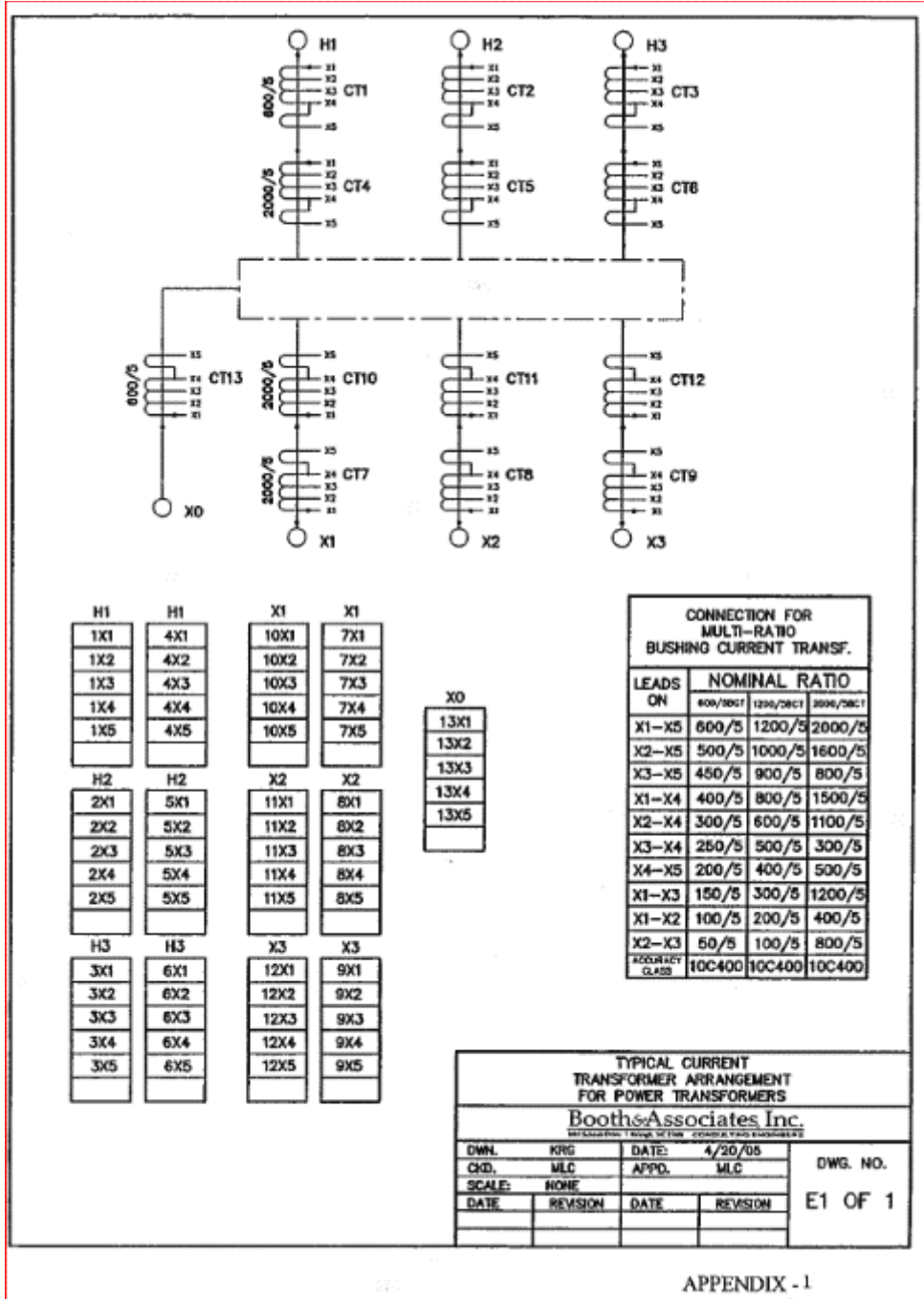

Appendix 2

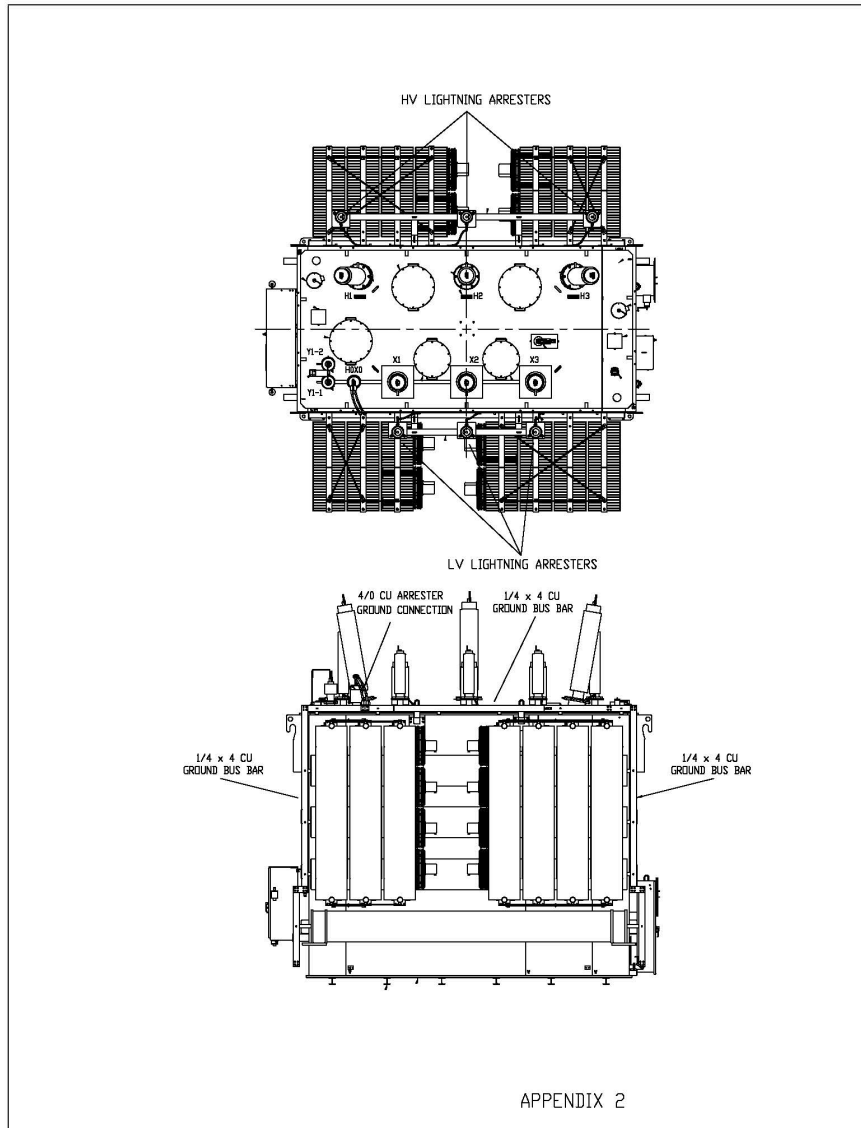

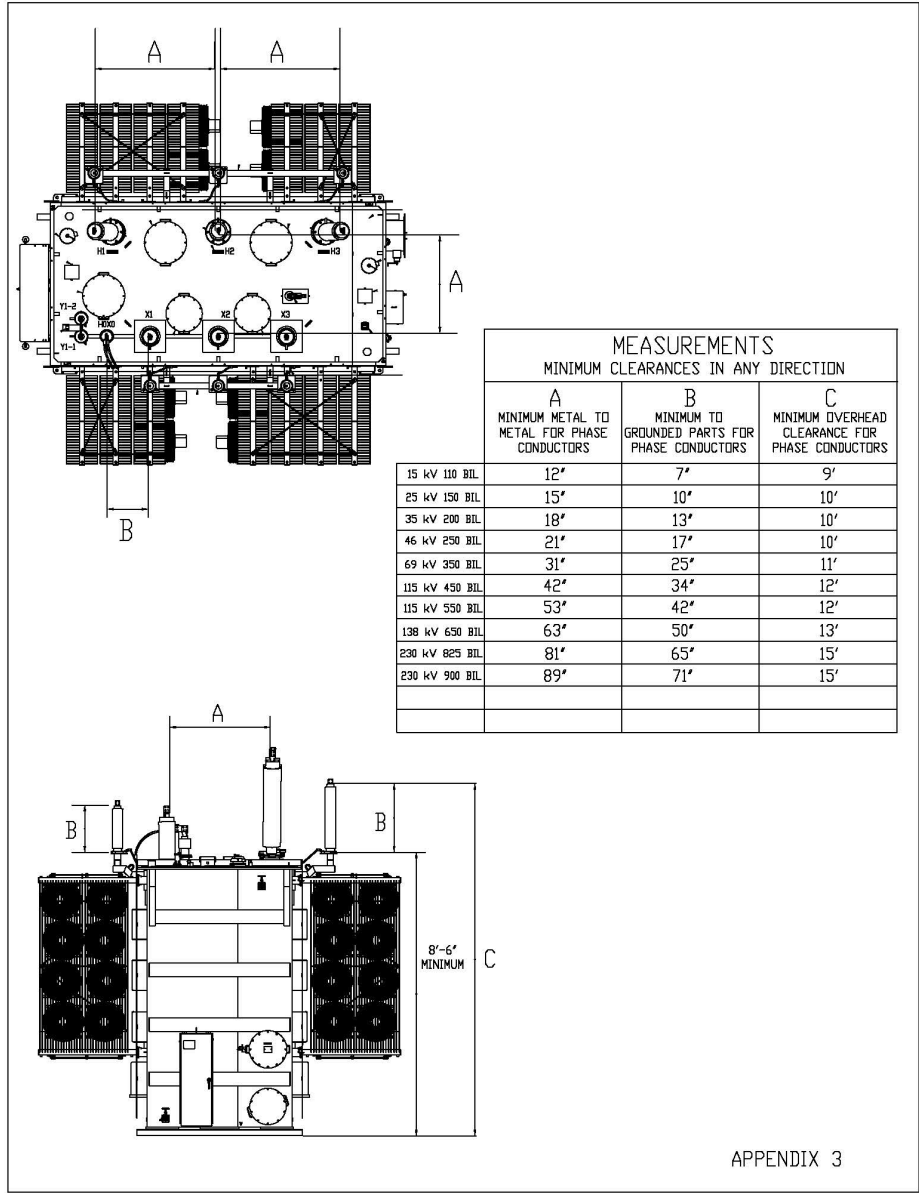

Appendix 3

Appendix 4

Yadkin 15 Substation at 4205 Legend Ave., Fayetteville, NC 28303

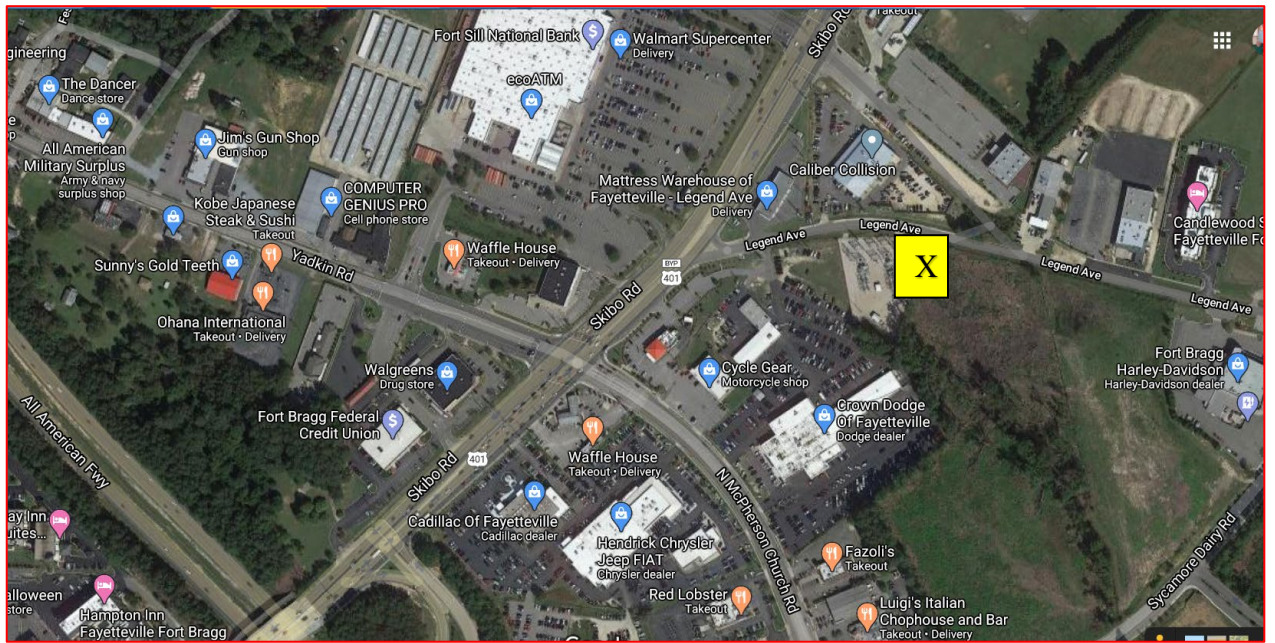

Appendix 5

DGA Specification

1. The online DGA must at a minimum measure the following parameters in the transformer oil
 - Hydrogen
 - Methane (CH₄)
 - Ethane (C₂H₆)
 - Ethylene (C₂H₄)
 - Acetylene (C₂H₂)
 - Carbon monoxide (CO)
 - Carbon dioxide (CO₂)
 - Moisture
2. Construction of the DGA is such that no plastic components are in contact with transformer oil.
3. All measurement components must be hermetically sealed to prevent leakage of transformer oil or gases. Oil Temperature Range: -40 to +120 °C
4. Measured DGA gases must not be vented to the atmosphere.
5. The online DGA shall not require any regular factory calibration or consumable gasses during its service lifetime.
6. The online DGA must have an autocalibration capability which must be made without use of any calibration gases or other consumables.
7. Measurement cycle shall not take longer than 2 hours in regular operations.
8. The measurement system of carbon gases must be optical and based on Non-Dispersive infrared (NDIR) technology.
9. The receiver of NDIR measurement system must not contain any mechanical parts such as microphones or mechanical chopper wheels or rotating filters.
10. NDIR measurement system must have ability to define its maximum IR transmission and compensate for any decrease in light source intensity.
11. No external pumps shall be needed to ensure flow of oil into the DGA.
12. Gases shall be extracted from the transformer oil using vacuum extraction method.
13. Use of membranes for gas separation from oil shall not be acceptable.
14. The online DGA must have integrated data logging capability for data storage up to 10 years. The on-line monitoring system shall be able to provide alarms based on single index increments.
15. The online system can be connected to SCADA using known protocols such as Modbus, DNP3 or IEC61850. It must support RS232, RS485, fiber-optic serial, fiber-optic ethernet, 4G, Ethernet carriers and include 3 x LED Indicators (Power, Service, Alarm) and Alarm relay contacts.

The on-line monitoring system shall be able to:

- Provide PD output in a single line energy trend which can be trended together with Load, H₂ production and all relevant indexes for diagnostic correlations;
 - Initiate a DGA sample based on PD readings
16. Installation should be able to be performed without an outage if required.
17. With regards to specific Dissolved Gas Analysis, the monitoring system shall have a user interface which provides the following Dissolved Gas Analysis:
- DGA Graph Trending
 - DGA Instantaneous Values
 - DGA Scheduling
 - DGA Online Monitor Alarm Management
 - Cross Data Trending
 - Data Export to User device
18. The supplier shall be capable of providing a team of transformer experts to support and enhance the customer experience providing monitor support and technical transformer service. Costs for these services will be agreed with the customer in advance based on a per project or transformer basis.
19. The supplier should also be able to support OEM Design for specification review and acceptance tests and provide training across all aspects of transformer operational life.
20. The online DGA enclosure must be rated to IP66. Enclosure to be constructed of 304 SS stainless steel that is white powder coated.
- The enclosure shall be further protected with a rain shield lip covering swing door.
21. A factory calibration test-report for the online DGA must be included during the delivery.
22. The unit shall be capable to tolerate vacuum and overpressure.
23. The DGA must have an automatic recovery after power outage without any user intervention
24. Sensor Specifications

For Hydrogen

Measurement range (in oil)	:	5 to 5000 ppm
Accuracy (in oil temp. range -20 ... +60 °C)	:	15%of reading or 25 ppm (whichever is greater)
Repeatability	:	10% of reading or 15 ppm (whichever is greater)
Typical long-term stability	:	3 %of reading / year
Cross Sensitivity to Other gases	:	< 2 %(CO ₂ , C ₂ H ₂ , C ₂ H ₄ , CO)
Sensor	:	Catalytic Solid-State Sensor

For Methane (CH₄)

Measurement Range	:	20 - 50 000 ppm
-------------------	---	-----------------

Accuracy : 10 ppm or 10 % of reading
Repeatability : 10 ppm or 5 % of reading

For Ethane (C₂H₆)

Measurement Range : 0 - 10 000 ppm
Accuracy : 10 ppm or 10 % of reading
Repeatability : 10 ppm or 5 % of the average of 5 reading

For Ethylene (C₂H₄)

Measurement Range : 5 - 90 000 ppm
Accuracy : 10 ppm or 10 % of reading
Repeatability : 10 ppm or 5 % of reading

For Acetylene (C₂H₂)

Measurement Range : 2 - 5 000 ppm
Accuracy : 2 ppm or 5 % of reading
Repeatability : 1 ppm or 10 % of reading

For Carbon monoxide (CO)

Measurement Range : 25 - 20 000 ppm
Accuracy : 10 ppm or 10 % of reading
Repeatability : 10 ppm or 5 % of reading

For Carbon dioxide (CO₂)

Measurement Range : 0 ... 10 000 ppm
Accuracy : 10 ppm or 10 % of reading
Repeatability : 10 ppm or 5 % of reading

For Moisture

Measurement Range : 5 to 95 %RS / Water Activity
0 to 1/ non-condensing
Accuracy (including non-linearity, hysteresis and repeatability) : ±2 ppm or ±10% of reading
Sensor : Capacitive Polymer
Calibration : Lowest calibration point <2%RH
Certificate supplied.

25. The online DGA must be able to operate in the following environment

Operating humidity range : 5 to 95%RH, non-condensing
Operating Temperature Range : -40 to +55 °C

Manufacturer's test report for Ingress Protection reports must be submitted with the proposal.

26. The online DGA must have the following communications output options

- RS485 which support Modbus RTU and DNP3 ethernet
- TCP/IP which supports Modbus TCP/IP, DNP3, and HTTP
- include 3 x LED Indicators (Power, Service, Alarm) and Alarm relay contacts
- support RS232, RS485, Fiber optic, Fiber-optic Ethernet, 4G cellular, Ethernet carriers

27. No additional software than a Browser shall be required for commissioning and data interpretation. All advanced diagnostic charts (Duval's Triangle, Bushing Polar Plot, Trends...) should be visible without installing any desktop software or server, but just using a Browser (IE10, Chrome, Firefox). The Overall Dashboard must display in one single page the gas levels, temperatures (top oil, environmental, tap changer and LTC differential if equipped), and load values.
28. The Web browser-based user interface shall contain the following information from the DGA
 - All measured parameters in graph format
 - All measured parameters in tabular format showing most recent measured values, 1-day average values, 1-day rate of change and 30 days rate of changes
29. The user must be able to download this data in comma separated values (.csv) format directly from the web browser
30. The user must be able to start and stop the measurement of the online DGA using the web browser interface.
31. The user must be able to configure the relays directly from the web browser.
32. Declaration of Conformity or Certificate for EMC & safety type tests according to IEC standards must be provided.
33. Operating power of the unit shall be 60 hertz single-phase 120-240 AC voltage. Other operating voltages allowed is 48-volt DC.