



CONTRACT DOCUMENTS &

TECHNICAL SPECIFICATIONS

PWC2223051

AST SYSTEM CONVERSION TO UST SYSTEM

ISSUED FOR BID

MAY 2023

Fayetteville Public Works Commission

Administrative Building

955 Old Wilmington Road

Fayetteville, NC 28301

TABLE OF CONTENTS

SECTION A – PROJECT SPECIFICS

General

Advertisement for Bids

00100 – Instructions to Bidders

Bid Submittal Documents

Bid Schedule – Performance and Delivery

Bid Checklist

00300 – Bid Pricing Form

Contractor Qualification Forms

Bid Supplemental Forms and Attachments

City of Fayetteville Small Business Enterprise Program

SDBE Program

SDBE Program Forms

SECTION B – CONTRACT EXECUTION DOCUMENTS

Notice of Award

Acceptance of Award

Construction Agreement

PWC General Conditions

Contract Supplemental Forms and Attachments

Notice to Proceed

SECTION C – ADMINISTRATIVE PROVISIONS

DIVISION 1 – GENERAL REQUIREMENTS

01000 – Supplementary Conditions

01025 – Measurement and Payment

01300 – Submittals

01400 – Quality Control

01700 – Project Closeout

16231 - Standby Power Systems – Lift Stations *rev 1.1.10*

APPENDICES

Appendix A – AST System Conversion to UST System Drawings

Appendix B – Permit

Appendix C – Sales Tax Form

SECTION A – PROJECT SPECIFICS GENERAL

***** THIS PAGE WAS INTENTIONALLY LEFT BLANK *****

**ADVERTISEMENT FOR BID
FAYETTEVILLE PUBLIC WORKS COMMISSION
AST SYSTEM CONVERSION TO UST SYSTEM**

**Cumberland County
North Carolina**

Pursuant to N.C.G.S 143-129, sealed bids are solicited and will be received at Fayetteville Public Works Commission, Administration Building, Conference Room 107, 955 Old Wilmington Road, Fayetteville, NC 28301, until **Tuesday May 23, 2023 @ 2:00pm** which time they will be publicly opened and read for construction of:

Remove the existing 20,000-gallon Gasoline and 10,000-gallon Diesel Fuel Above Ground Storage Tanks at Fayetteville Public Works Commission, 955 Old Wilmington Road, Fayetteville, North Carolina 28301. Provide and install new 20,000-gallon Underground Storage Tanks for Gasoline and Diesel Fuel as shown and specified on the plans titled "AST System Conversion to UST System". This work includes but is not limited to the removal of existing gasoline/fuel tanks, concrete containment, valves, piping, pumps, disposal of the existing above-ground storage tanks, installation of the new tanks as shown and specified, restoration, and all incidentals necessary to complete the specified repairs.

The foregoing description shall not be construed as a complete description of all work required. All work shall be done in accordance with PWC technical specifications and standard contract terms.

A **NON-MANDATORY** pre-bid meeting will be held on **Tuesday May 16, 2023 @ 10:00am**, in the Conference Room 107, Fayetteville Public Works Commission, Administrative Building, 955 Old Wilmington Road, Fayetteville, NC 28301. Representatives of the Owner and Engineer will be available to answer questions. Any formal bid submitted by a Bidder that fails to attend this meeting will be considered an unresponsive bid.

Questions will be fielded at the pre-bid meeting and all prospective bidders are required to attend the meeting. Individual telephone inquiries are prohibited. The PWC assumes no responsibility to fully inform absentees of clarifications not issued by addendum.

Bids must be enclosed in a sealed envelope addressed to Shelby Lesane, Procurement Advisor, Fayetteville Public Works Commission, 955 Old Wilmington Road, Fayetteville, North Carolina 28301. The outside of the envelope must be marked **SEALED BID: AST SYSTEM CONVERSION TO UST SYSTEM** and shall indicate the name, address and state license number of the bidder. Bids shall be submitted on the printed forms, or exact copies thereof, contained in the Contract Documents.

Each bid shall be accompanied by a bid bond of five percent (5%) of the bid executed by a surety company licensed under the laws of North Carolina to execute the Contract in accordance with the bid bond and upon failure to forthwith make payment, the surety shall pay the obligee an amount equal to the amount of said bond. Said deposit shall be retained by the Owner as liquidated damages in event of failure of the successful bidder to execute the Contract within ten (10) days after the Notice of Award or give satisfactory surety as required by law.

Performance and Payment Bonds are required in the amount of 100% of the Contract amount and shall be furnished by the Contractor.

All Contractors are notified that North Carolina Statutory provisions as to licensing of Contractors will be followed as applicable in receiving and evaluating bids and in reading and awarding the Contract (Chapter 87 of the North Carolina General Statutes).

The license classification shall be:

Part 1: Unclassified - Unlimited

Plans and Specifications including Contract Documents will be available online for viewing and downloading on or about **Friday May 5, 2023**, on the PWC Procurement website at <https://www.faypwc.com/purchasing>. In addition, the documents will be available from the Fayetteville State University Construction Resource Office (FSU CRO) at <https://www.uncfsu.edu/academics/colleges-schools-and-departments/broadwell-college-of-business-and-economics/outreach-centers/construction-resource-office>. In collaboration with the North Carolina Institute of Minority Economic Development, the FSU CRO offers services and support to help small, minority, veteran, and women-owned businesses identify and compete for construction-related projects.

At the FSU CRO, potential bidders may:

- Research, view and print project drawings to scale free of charge;
- Use available software to prepare their bid; and
- Receive certification and pre-qualification assistance.

Please email the FSU CRO to make an appointment: fsucro@uncfsu.edu

Plans and Specifications are also being furnished to ISQFT (www.isqft.com) for online posting. Purchase of the documents is not required to bid.

Fayetteville Public Works Commission reserves the right to reject any or all bids for any reason determined by PWC to be in its best interest, or to award the bid to the lowest responsible bidder or bidders, taking into consideration quality, performance, and the time specified in the bids for the performance of the contract.

The bidder to whom the contract may be awarded must comply fully with the requirements of North Carolina General Statutes Section 143-129, as amended.

No bids may be withdrawn after the scheduled Bid Opening for a period of ninety (90) calendar days.

FAYETTEVILLE PUBLIC WORKS COMMISSION
Tanga Anderson-Solomon
Procurement Manager

**00100 - INSTRUCTIONS TO BIDDERS
FAYETTEVILLE PUBLIC WORKS COMMISSION
AST SYSTEM CONVERSION TO UST SYSTEM**

A. DEFINED TERMS

Terms used in these Instructions to Bidders are defined in the Definitions and Terminology sections of the PWC General Conditions.

B. COPIES OF BIDDING DOCUMENTS

1. Complete sets of the Bidding Documents as stated in the Invitation to Bidders, may be obtained from the PWC Procurement Department.
2. Complete sets of Bidding Documents shall be used in preparing Bids. PWC assumes no responsibility for errors or misinterpretations resulting from the use of incomplete sets of Bidding Documents.

C. EXAMINATION OF CONTRACT DOCUMENTS, OTHER RELATED DATA, AND PROJECT SITE

1. Before submitting a Bid, each Bidder shall (a) examine the Contract Documents thoroughly, (b) visit the site and become familiar with the site and any local conditions that may in any manner affect the cost, progress, or performance of the Work, (c) be familiar with federal, state and local laws, ordinances, rules and regulations that may in any manner affect cost, progress or performance of the Work, and (d) study and carefully correlate Bidder's observations with the Contract Documents, and (e) give the PWC Procurement Advisor written notice of all conflicts, errors or discrepancies in the Contract Documents.
2. Bidders should consult the Specifications for the identification of those reports of investigations and tests of subsurface and latent physical conditions at the site or reports that otherwise may affect cost, progress, or performance of the Work which may have been utilized in the preparation of the Drawings and Specifications. PWC will make copies of such reports if available at the cost (non-refundable) of reproduction to any Bidder requesting them. These reports are not intended to constitute any explicit or implicit representation as to the nature of the subsurface and latent physical conditions, which may be encountered at the site or to constitute explicit or implicit representations as to any other matter, contained in any report. Such reports are not guaranteed as to accuracy or completeness and are not part of the Contract Documents. Before submitting a Bid, each Bidder will, at its own expense, make such investigations and tests as the Bidder may deem necessary to determine his Bid for the performance of the Work in accordance with the Contract Documents.
3. On request (minimum 48 hours advance notice), PWC will provide each Bidder access to the site to conduct such investigations and tests, as each Bidder deems necessary for submission of its Bid.
4. The lands upon which the Work is to be performed, right-of-way for access thereto, and other lands available for use by the Contractor in performing the Work are identified in the Contract Documents.

5. The submission of a Bid constitutes an incontrovertible representation by the Bidder that it has complied with every requirement of this Section and that the Contract Documents are sufficient in scope and detail to indicate and convey an understanding of all terms and conditions for the performance of the Work.

D. INTERPRETATIONS AND ADDENDA

1. All questions about the meaning or intent of the bid or Contract Documents shall be submitted in writing to Shelby Lesane, Procurement Advisor, by email to shelby.lesane@faypwc.com. In order to receive consideration, questions must be received by **Thursday May 18, 2023, by 5:00pm**. Any interpretations of questions so raised, which in the opinion of the Project Engineer require interpretations, will be issued by Addenda via email or posted online by the Owner and/or Design Engineer. An Addendum extending the Bid Opening date may be issued up to five (5) business days before the Bid Opening date. An Addendum withdrawing the Invitation for Bid may be issued any time prior to the Bid Opening date. The Owner and Design Engineer will not be responsible for oral interpretations or clarifications, which anyone presumes to make on their behalf.

Bidders are expressly prohibited from contacting any PWC official or employee associated with this project, except as noted above. Violation of this prohibition is grounds for the immediate disqualification of the bidder.

2. PWC may issue such additional Addenda as may be necessary to clarify, correct, or change the Contract Documents. Such Addenda, if any, will be issued in the manner and within the time stated in Paragraph 1 of this Section.
3. Each Bidder shall be responsible for determining that all Addenda issued by PWC have been received before submitting a Bid for the Work.
4. Each Bidder shall acknowledge the receipt of each Addendum on the Bid Form.

E. SUBSTITUTE MATERIAL AND EQUIPMENT

The Contract, if awarded, will be on the basis of material and equipment described in the Drawings or required in the Specifications without consideration of possible substitute or "or-equal" items. The procedure for submittal of substitute or "or-equal" items for consideration is set forth in the PWC General Conditions.

F. CONTRACTOR'S LICENSE

1. No General Contractor shall engage in contracting work in the State of North Carolina unless it has been licensed under in accordance with North Carolina law.
2. Bidders are prohibited from contracting for, or bidding upon, the construction, removal, repair or improvements to or upon real property owned, controlled or leased by Fayetteville Public Works Commission without a North Carolina Contractor's License.
3. Each bidder shall indicate its North Carolina Contractor's License number on the bid envelope and the Bid Form.
4. License Classification shall be:

- Unclassified: Unlimited

G. SUBCONTRACTORS

1. Contractor shall subcontract no more than 49 percent (49%) of the value of the Contract.
2. Each Bidder shall submit to PWC with its bid the List of Subcontractors, Suppliers, other persons, and organizations proposed for those portions of the Work for which such identification is required. If PWC, after due investigation has reasonable objection to any proposed Subcontractor, Supplier, other person or organization, PWC may, before Notice of Award is given, request apparent Successful Bidder to submit an acceptable substitute without an increase in the Bid.
3. If the apparent Successful Bidder declines to make such a substitution, PWC may award the Contract to the next lowest responsive, responsible Bidder that proposes to use acceptable Subcontractors, Suppliers, and other persons, and organizations. The declining to make requested substitutions will not constitute grounds for sacrificing the bid security of any Bidder. If PWC does not make written objection to a Bidder's list of Subcontractors, Suppliers, other persons, or organizations prior to giving Notice of Award, the list will be considered acceptable, subject to revocation as provided in the PWC General Conditions.

H. SMALL LOCAL SUPPLIER (SLS) PROGRAM / SMALL DISADVANTAGED BUSINESS ENTERPRISE PROGRAM

1. PWC is committed to promoting the utilization of small, local businesses in the Fayetteville Metropolitan Statistical Area (MSA) by increasing opportunities for those businesses to participate in PWC procurements. The MSA consists of Cumberland County, Hoke County, and Harnett County. PWC requires Bidders to report efforts to utilize Small Disadvantaged Business Enterprises (SDBEs) and Historically Underutilized Businesses (HUBs) for specific projects and encourages all Bidders to report all such efforts for SDBEs, HUBs, and small, local businesses regardless of the requirements of a specific project. Bidders should document any good-faith efforts and utilization in the SDBE forms provided within the Contract Documents.
2. NCDOT Disadvantaged Business Enterprise (DBE) and NC Department of Administration (DOA) Historically Underutilized Business (HUB) firms with current certifications are acceptable for listing in the bidder's submittal of SDBE participation and will be considered to meet any necessary contract goal. Firms that are certified through NCDOT are listed at the "Vendor Directory" which can be accessed through the following: <https://www.ebs.nc.gov/VendorDirectory/default.html>. Firms that are certified through NC DOA are listed at the "HUB Vendor Search" which can be accessed through the following <https://www.doa.state.nc.us/HUB/searchhub.htm>.
3. Bidder shall submit, with their bid, the SDBE documentation required in the Contract Documents. It is strongly recommended that the Bidder attend the Pre-Bid Meeting, as important information will be reviewed.

I. SUBMISSION OF BIDS

1. All Bidders shall use the enclosed Bid Forms, or exact copies thereof, in submitting their

bid prices. PWC will not accept oral Bids or Bids received by telephone, email, or telecopier (FAX machine) for this Bid.

2. All prices must be F.O.B. delivered to the point as indicated by this Bid. PWC will grant no allowance for boxing, crating, or delivery unless specifically provided for in this Bid.
3. The Bid Form must be completed in black ink. Black or blue pen ink is acceptable if handwritten. Discrepancies between amounts shown in words and amounts shown in figures will be resolved in favor of the amounts shown in words. Discrepancies in the multiplication of units of Work and the unit prices will be resolved in favor of the correct multiplication of the unit prices. Discrepancies between the indicated sum of any column of figures and the correct sum thereof will be resolved in favor of the correct sum.
4. Bid submittals sent by mail should be registered mail. The sealed Bid, marked as indicated above, should be enclosed in an additional sealed envelope similarly marked and addressed to:

Fayetteville Public Works Commission
Attn: Shelby Lesane, Procurement Advisor
955 Old Wilmington Road
Fayetteville, North Carolina 28301

5. Mark the envelope in the lower left-hand corner with the project title, hour and due date of Bid, and the Bidder's North Carolina contractor registration number.
6. Bids sent by mail and arriving after the time for the opening of Bids shall not be considered valid Bids. In such instances, the Bidders shall have no claim against PWC.
7. All items contained in the Bid Checklist shall be completely filled out and submitted with the bid. Failure to submit any of the items requested with the Bid Form may be just cause for rejection of the Bid by PWC.
8. All erasures, insertions, additions, and other changes made by the Bidder to the Bid Form shall be signed or initialed by the Bidder. Bids containing any conditions, omissions, erasures, alterations, or items not called for in the Bid, may be rejected by PWC as being incomplete or nonresponsive.
9. The Bid Form must be signed in order to be considered. If the Bidder is a corporation, the Bid must be submitted in the name of the corporation, not simply the corporation's trade name. In addition, the Bidder must indicate the corporate title of the individual signing the Bid.
10. The Bid Form, the Bid security, if any, and any other documents required, shall be enclosed in a sealed opaque envelope. Any notation or notations on the exterior of the envelope purporting to alter, amend, modify, or revise the bid contained within the envelope shall be of no effect and shall be disregarded.
11. All Bids received in the Procurement Department by the deadline indicated will be kept sealed until the time and date of the Bid Opening.
12. All late Bids shall be returned unopened to the sender.

J. BID BOND

1. Each Bid shall be accompanied by an acceptable Bid bond in the amount of five percent (5%) of the Bid amount, and made payable to Fayetteville Public Works Commission, North Carolina.
2. The Bid bond is a guarantee that if the contract is awarded by PWC to the Bidder, the Bidder shall enter into the contract with PWC for the work mentioned in this Bid or forfeit the Bid bond to PWC, not as a penalty, but as liquidated damages.
3. No forfeiture under a Bid bond shall exceed the lesser of (a) the difference between the Bid for which the Bid bond was written and the next low Bid of another Bidder, or (b) the face amount of the Bid bond.
4. All bonds shall be executed by a surety company selected by the Bidder, which is legally authorized to do business in the State of North Carolina (NCGS §44 A-26), and the bond shall be the same in both form as well as substance as AIA Document A310, Bid Bond.
5. The Bidder shall require the attorney-in-fact, who executed the required bond on behalf of the surety company, to affix thereto a certified and current copy of the power of attorney.
6. The bond premium shall be paid by the Bidder and the cost shall be included in the Bid price.
7. Any inspection of procurement transaction records shall be subject to reasonable restrictions to ensure the security and integrity of the records.

K. OPENING OF BIDS

1. Bids will be opened publicly and read aloud on the date and time set for the Bid Opening in the Notice to Bidders.
2. Any Bidder, upon request, shall be afforded the opportunity to inspect Bid records within a reasonable time after the opening of all Bids but prior to award, except in the event that PWC decides not to accept any of the Bids and to reopen the contract. Otherwise, bid records shall be open to public inspection only after the award of the Contract.
3. Any inspection of procurement transaction records shall be subject to reasonable restrictions to ensure the security and integrity of the records.

L. MODIFICATION OF BIDS

1. A Bid may be modified or withdrawn by the Bidder at any time prior to the time and date set for the Bid Opening. The Bidder shall notify the PWC Procurement Department in writing of its intentions.
2. Modified and withdrawn Bids may be resubmitted to the PWC Procurement Department up to the time and date set for the Bid Opening.

M. WITHDRAWAL OF BID DUE TO ERROR

1. If the Bidder desires to withdraw its Bid, the Bidder must do so before the time fixed for the opening, without prejudice, by communicating its purpose in writing to PWC. After bids are open, bids may only be withdrawn in strict accordance with N.C.G.S. Section 143-129-

N. BIDS TO REMAIN OPEN

1. All Bids shall remain open for ninety (90) calendar days after the day of the Bid Opening.

O. ESTIMATED QUANTITIES

1. The estimated quantities contained herein in certain items in the Bid are for the purpose of comparing bids, and while they are believed to be close approximations, they are not guaranteed, and settlement will be made on the basis of the work as actually executed at the unit prices in the Bid as accepted. PWC further reserves the right to delete any single line item or combination of items from the bid and cannot guarantee that all quantities listed in the Contract Documents will be utilized.
2. The Contractor should verify quantities before submitting a bid. Due to conditions that may be found under pavement such as the accurate location of existing water lines, sewer lines, gas lines, and structure services of all types, quantities are subject to change during construction, but this contingency shall not be used for a claim to change unit prices submitted in the Bid.

P. AWARD OF CONTRACT

1. PWC reserves the right to reject any and all Bids, to waive any and all informalities, and to disregard all nonconforming, nonresponsive, or conditional Bids. PWC reserves the right to request additional information from any or all bidders for evaluation purposes. Failure or refusal to furnish additional information as requested may result in the rejection of the bid.
2. In case of a tie Bid, the tie shall be decided by lot.
3. It is the intent of the PWC to recommend the award of this contract to the lowest responsive, responsible Bidder provided the Bid has been submitted in accordance with the requirements of the Bidding Documents and does not exceed the funds available. In determining the lowest responsible Bidder, PWC may consider, among other criteria, the Bidder's past performance conduct on other contracts, and other information provided by the Bidder as noted below.
4. In determining the lowest responsive Bidder, PWC will evaluate the Bidder's proposed Bid price and the completeness of the submitted bid in accordance with the requirements of the Contract Documents.
5. PWC may consider the operating costs, maintenance considerations, performance date, and guarantees of materials and equipment.
6. PWC may conduct such investigations as deemed necessary to assist in the evaluation of any Bid and to establish the responsibility, qualifications and financial ability of the Bidders, as well as other considerations, to include but not limited to resources available to the Bidder to perform the work effectively, proposed Subcontractors and other persons and organizations to do the work in accordance with the Contract Documents to PWC's satisfaction within the prescribed time.

7. PWC reserves the right to reject the Bid of any Bidder who does not pass any such evaluation to PWC's satisfaction.
8. If the Contract is to be awarded, PWC will give the Successful Bidder a Notice of Award within ninety (90) days after the day of the Bid Opening.
9. The Bidder to whom the contract is awarded shall, within ten (10) days after prescribed documents are presented for signature, execute and deliver the Contract Documents and any other forms or bonds required by the Bid to PWC.
10. The Bidder is required to complete the attached forms that will allow PWC to verify that the Bidder is qualified to perform the Work described in these Contract Documents. All forms shall be completed and submitted with the Bid. Failure to submit all the required forms shall be considered grounds for PWC to reject the bid.

PWC will review all of the bids and qualification data to determine the lowest responsive, responsible Bidder. PWC reserves the right to not award the Contract to the lowest bidder if the information provided is not complete, does not meet the satisfaction of PWC, or has been falsified. PWC will not request any additional information in order to allow the Contractor to complete bid.

11. During the evaluation phase, bid submittals will be reviewed to ascertain which bids technically and otherwise address all the requirements of these Contract Documents. Bid submittals determined to be technically non-responsive or not sufficiently responsive may be disqualified.

The Bidder shall address each of the Evaluation Criteria as requested in the Technical Evaluation Criteria Form located within Section A Project Specifics Bid Submittal Documents. To be considered substantive, the information must respond to all requirements.

12. PWC may conduct such investigations/verifications as deemed necessary to establish the responsibility, qualification and financial ability of the Bidder. Should PWC find that the apparent low bidder is not the lowest responsive, responsible bidder by integrity of the information furnished, said apparent low bidder will be so notified and its bid bond shall be returned without prejudice. Failure or refusal to furnish any items of information requested by PWC shall be considered as non-responsive and therefore basis for rejection of the bid.

Q. TAXES

1. The Successful Bidder shall pay all county, city, state and federal taxes required by laws in effect at the time Bids are received and resulting from the Work or traceable thereto, under whatever name levied.
2. Said taxes shall not be in addition to the contract price between PWC and the Successful Bidder. The taxes shall be an obligation of the Successful Bidder and not of PWC. PWC shall be held harmless from same by the Successful Bidder.

R. PERFORMANCE AND OTHER BONDS

1. The PWC General Conditions set forth PWC's requirements as to Performance and other Bonds.

S. E-VERIFY REQUIREMENTS

1. Contractor hereby acknowledges that "E-Verify" is the federal E-Verify program operated by the US Department of Homeland Security and other federal agencies which is used to verify the work authorization of newly hired employees pursuant to federal law and in accordance with Article 2, Chapter 64 of the North Carolina General Statutes.
2. Contractor further acknowledges that all employers, as defined by Article 2, Chapter 64 of the North Carolina General Statutes, must use E-Verify and after hiring an employee to work in the United States, shall verify the work authorization of the employee through E-Verify in accordance with NCGS §64-26(a).
3. Contractor hereby pledges, attests and warrants through execution of this Agreement that Contractor complies with the requirements of Article 2, Chapter 64 of the North Carolina General Statutes and further pledges, attests and warrants that any subcontractors currently employed by or subsequently hired by Contractor shall comply with any and all E-Verify requirements. Failure to comply with the above requirements shall be considered a breach of this Agreement.

T. IRAN DIVESTMENT ACT

1. As mandated by N.C.G.S. 147-86.59(a), the Contractor hereby certifies that it is not listed on the Final Divestment List created by the North Carolina State Treasurer pursuant to N.C.G.S. 147-86.58. Contractor further certifies that in accordance with N.C.G.S. 146-86.58(b) that it shall not utilize any subcontractor found on the State Treasurer's Final Divestment List. Contractor certifies that the signatory to this Purchase Order authorized by the Contractor to make the foregoing statement.

*** END OF SECTION ***

**SECTION A – PROJECT SPECIFICS
BID SUBMITTAL DOCUMENTS**

**BID SCHEDULE – PERFORMANCE AND DELIVERY
FAYETTEVILLE PUBLIC WORKS COMMISSION
AST SYSTEM CONVERSION TO UST SYSTEM**

Pre-Bid Meeting:	10:00am, Tuesday, May 16, 2023
(NON - MANDATORY)	Fayetteville Public Works Commission Administrative Bldg. Conference Room 107 955 Old Wilmington Road Fayetteville, NC 28301
Deadline for Questions from Bidders ¹	5:00pm, Thursday May 18, 2023
Deadline for Addenda issued by PWC Procurement Department and Project Engineer ²	5:00pm, Friday, May 19, 2023
Bid Opening (Submittal Deadline)	2:00pm, Thursday, May 23, 2023
	Fayetteville Public Works Commission Administrative Building Conference Room 107 955 Old Wilmington Road Fayetteville, NC 28301
Contract Time:	60 Calendar Days from Notice to Proceed
Liquidated Damages:	\$250.00 per day for each day beyond the Final Completion Date
Bid Acceptance Period	Within ninety (90) Calendar Days unless otherwise noted

-
1. Questions regarding this bid must be submitted in writing to the attention of Shelby Lesane, Procurement Advisor, by email to shelby.lesane@faypwc.com.

Bidders are expressly prohibited from contacting any FPWC official or employee associated with this Invitation to Bid, except as noted above. Violation of this prohibition is grounds for the immediate disqualification of the bidder.

2. Any addenda to these Contract Documents will be issued by the Project Engineer no later than the date and time stated above.

BID SUBMITTAL CHECKLIST

- 1. Enter Contractor's License Number where called for in the Bid Form and on the outside of the sealed envelope containing the Bid.
- 2. Photocopy of Contractor's License.
- 3. Bid Bond
- 4. Bid Forms Section 00300.
- 5. Provide the responsible North Carolina Registered Agent for Insurance Claims. Include contact information.
- 6. Provide the proposed responsible Bonding Company name. Include contact information.
- 7. List of proposed Subcontractors and material suppliers exceeding 5% of the Contract Value.
- 8. Non-Collusive Affidavit.
- 9. Nondiscrimination Clause.
- 10. Affidavit of Organization and Authority and Sworn Statement.
- 11. Equal Employment Opportunity Acknowledgment.
- 12. Certification regarding Debarment, Proposed Debarment, and other Responsible Matters.
- 13. FTA Certification Regarding Lobbying.
- 14. Identification of Minority Business Participation Form.
- 15. Affidavit A – Listing of Good Faith Efforts, et al.
- 16. Affidavit B – (Only if the Contractor will perform **ALL ELEMENTS OF THE WORK** on this project with their own forces **AND** will complete **ALL ELEMENTS OF THIS PROJECT WITHOUT THE USE OF SUBCONTRACTORS, MATERIAL SUPPLIERS, OR PROVIDERS OF PROFESSIONAL SERVICES.**

FAILURE TO SUBMIT THE ABOVE FORMS WITH THE BID FORM MAY BE JUST CAUSE FOR REJECTION OF THE BID BY THE OWNER

***** THIS PAGE INTENTIONALLY LEFT BLANK *****

00300 - BID FORM

TO: **Fayetteville Public Works Commission**
Attn: Shelby Lesane, Procurement Advisor
955 Old Wilmington Road
Fayetteville, North Carolina 28301

PROJECT: **AST SYSTEM CONVERSION TO UST SYSTEM**

FROM: BIDDER _____

ADDRESS _____

DATE OF BID _____, 20 ____

- A. The undersigned BIDDER proposes and agrees, if this Bid is accepted, to enter into a Contract with OWNER in the form included in the Contract Documents to perform and furnish all Work (as that term is defined in the Construction Agreement) specified or indicated in the Contract Documents for the Contract Price and within the Contract Time indicated in this Bid and in accordance with the Contract Documents.
- B. BIDDER accepts all of the terms and conditions of the Instructions to Bidders, including, without limitation, those dealing with the disposition of payment and performance bonds, and insurance certificates. This bid will remain open for ninety (90) calendar days after the day of Bid opening. BIDDER will sign the Contract and submit the Contract Security and other documents required by the Contract Documents within ten (10) days after the date of receipt by the BIDDER.
- C. In submitting this Bid, Bidder represents, as more fully set forth in the Contract, that:
 - 1. BIDDER has examined copies of all the Contract Documents and of the following addenda, receipt of all which is acknowledged on the bid summary page:
 - 2. BIDDER has examined the site and locality where the Work is to be performed, the legal requirements (federal, state, and local laws, ordinances, rules and regulations) and the conditions affecting cost, progress of performance of the work and has made such independent investigations as BIDDER deems necessary.
 - 3. BIDDER acknowledges that OWNER does not assume responsibility for the accuracy of dimensions or completeness of information and data shown or indicated in the Bidding Documents with respect to existing facilities.
 - 4. BIDDER has carefully studied all reports of explorations and tests of subsurface conditions at or contiguous to the site of the Work (except underground facilities) and all drawings of physical conditions in or relating to existing surface or

subsurface structures, pipelines, and utilities at or contiguous to the site are provided within these Contract Documents. Geotechnical Reports and other information regarding subsurface conditions are identified in the attached appendices and detailed in Article V of the PWC General Conditions. BIDDER acknowledges that the OWNER does not assume responsibility for the accuracy or completeness of information and data shown or indicated in the Bidding Documents with respect to underground facilities at or contiguous to the site of Work. BIDDER had obtained and carefully studied (or assumes responsibility for have done so) all such additional or supplementary examinations investigations, explorations, tests, studies, and data that are necessary to identify and understand conditions (surface, subsurface, and underground facilities) at or contiguous to the site of Work or otherwise which may affect cost, progress, performance, or furnishing the Work or which relate to any aspect of means, methods, techniques, sequences, and procedures of construction to be employed by Bidder and safety precautions and programs incident thereto. BIDDER waives all rights to claim that any additional examinations, investigations, explorations, tests, studies, or data are necessary for the proper submission of the Bid for the performance and furnishing of the Work in accordance with the Contract Time, Contract Price, and other terms and conditions of the Contract Documents.

5. BIDDER hereby certifies that, if awarded the Contract for construction of the Project, it will take all possible actions to minimize costs to the OWNER which are related to any disruptions in any part of the Work resulting from unforeseeable conditions which may be encountered and work changes or additions which may be made.
6. BIDDER has correlated the information known to BIDDER, information and observations obtained from visits to the site, reports and drawings identified in the Contract Documents, and all additional examinations, investigations, exploration, tests, studies, and data with the Contract Documents.
7. BIDDER has given OWNER written notice of all conflicts, errors, ambiguities, or discrepancies that BIDDER has discovered in the Contract Documents and the written resolution thereof by OWNER is acceptable to BIDDER, and the Contract Documents are generally sufficient to indicate and convey understanding of all terms and conditions for performing and furnishing the Work for which this Bid is submitted.
8. By bidding in response to this invitation, the BIDDER represents that in the preparation and submission of this Bid, said BIDDER did not, either directly or indirectly, enter into any combination or arrangement with any person, firm or corporation or enter into any agreement, participate in any collusion, or otherwise take any action in the restraint of free, competitive bidding in violation of the Sherman Act (15 U.S.C. Section 1).
9. Bid form must be completed in blue or black ink or by typewriter. The Bid price of each item on the form must be stated in both words and numerals. In case of a

conflict, words shall take precedence. Discrepancies in the multiplication of units of work and unit prices will be resolved in favor of the correct multiplication of the unit prices. Discrepancies between the indicated sum of any column of figures and the correct sum thereof will be resolved in favor of the correct sum.

10. BIDDER understands that the award of contract will be made on the basis of the total Bid amount which will be determined as the sum of the unit price and lump sum Bid Items.
11. BIDDER understands that quantities are estimated and are not guaranteed; they are solely for comparing Bids and establishing the total Bid amount. The Price will be modified by Change Order, and final payment will be based on the quantities of work actually furnished and installed by the successful BIDDER.
12. BIDDER shall complete the Work for the prices indicated on the next page.

BID PRICING FORM – BASE BID

Having become completely familiar with the local conditions affecting the cost of work at the place where work is to be executed, and having carefully examined the site conditions as they currently exist, and having carefully examined the plans and specifications prepared by Haggett Engineering Associates, Inc. and titled AST System Conversion to UST System dated November 2, 2022 together with Bidding Documents prepared by Fayetteville Public Works Commission and any addenda as listed hereinafter, the undersigned hereby proposes and agrees to provide all labor, materials, plant, equipment, transportation and other facilities as necessary and/or required to execute all of the work described by the aforesaid Bidding Documents for the lump sum consideration of: (Bidder shall write in the amount of the base bid here)

Dollars (\$ _____)

Total of Contingency + \$ 10,000

Total Base Bid _____

said amount being hereinafter referred to as the Total Base Bid or Total Base Bid Proposal.

ALTERNATES:

The undersigned proposes to perform alternates for stated additions to or deductions from the Base Bid. Additions and deductions shall include any modifications of work or additional work that undersigned may be required to perform by reason of the acceptance of any alternate. (Bidder shall write in the amounts for the alternates listed below)

ALTERNATE NO. 1: (none)

Adjust Base Bid by [ADDING or DELETING] _____

_____ Dollars (\$ _____)

ALTERNATE NO. 2: (none)

Adjust Base Bid by [ADDING or DELETING] _____

_____ Dollars (\$ _____)

BID BREAKDOWN:

For the Owner's accounting purposes only, the following Base Bid cost breakdown is provided. It is agreed upon that this information will not be used for any decisions to determine the award of this Contract. This information is required of all applicable Contractors. (Bidder shall write in the amounts for the category breakdown listed)

- BID SUMMARY-

TOTAL BASE BID \$ _____

TOTAL ALTERNATE BID \$ _____

The BIDDER has received, acknowledged, and used the following addenda in completing the Bid. (Initial and Date as appropriate).

Addendum No. 1	Date _____
Addendum No. 2	Date _____
Addendum No. 3	Date _____
Addendum No. 4	Date _____
Addendum No. 5	Date _____
Addendum No. 6	Date _____
Addendum No. 7	Date _____

The undersigned BIDDER certifies that they are licensed as a Contractor under N.C.G.S § 87, and that their license number is _____ (License Number).

The undersigned BIDDER hereby agrees to accept an award of the Contract based on the Total Contract Amount as accepted by the OWNER and as indicated on the Notice of Award.

A. BIDDER agrees that Work shall be completed within the time frame indicated in the Agreement as follow:

1. All work described herein to be complete, including restoration and all punch list items from Notice to Proceed within 60 days.
2. The BIDDER acknowledges that time is of the essence in this Contract and that the OWNER will suffer financial loss if the Work is not complete within the time specified in Paragraph D.1 above plus any extensions thereof allowed in accordance with these Contract Documents. BIDDER also recognizes the delays, expense and difficulties involved in proving in a legal proceeding the actual loss suffered by the OWNER if the Work is not complete on time. The Bidder agrees to diligently pursue all available work and complete all work in an expeditious manner.

B. The following documents are attached to and made part of this bid:

Required Bid Security in the form of either a cashier's check or certified check or Bid Bond in the amount of 5% of maximum Bid price.

C. Communications concerning this Bid shall be addressed to: (CONTRACTOR's Name, Address and Telephone Number)

D. The terms used in this Bid which are defined in Definitions and Terminology Section of the PWC General Conditions or as otherwise specifically defined in the Contract Documents have the meanings assigned to them therein, which are incorporated by reference as if fully set forth herein.

E. An individual contractor is required to furnish his social security number and sole proprietorship, partnership and corporation are required to furnish their employer identification numbers to Fayetteville Public Works Commission. Please indicate this information on this Bid Form as follows:

Social Security Number: _____

Federal Employer Identification Number: _____

SUBMITTED ON ____ day of _____ 2023

AN INDIVIDUAL

BY: _____ (SEAL)

(Individual's Name and Signature)

Doing Business as: _____

North Carolina Contractor Registration Number: _____

Business Address: _____

Phone Number: _____

Subscribed and sworn to before me this ____ day of _____ 2023

NOTARY PUBLIC

My Commission Expires: _____

A PARTNERSHIP

BY: _____ (SEAL)

(Firm Name)

(General Partner and Signature)

North Carolina Contractor Registration Number: _____

Business Address: _____

Phone Number: _____

Subscribed and sworn to before me this ____ day of _____ 2023

NOTARY PUBLIC

My Commission Expires: _____

A CORPORATION

BY: _____
(Corporation Name) (State of Incorporation)

BY: _____ (SEAL)
(Name and Title of Person Authorized to Sign and Signature)

ATTEST: _____
(Secretary or Assistant Secretary and Signature)

North Carolina Contractor Registration Number: _____

Business Address: _____

Phone Number: _____

Subscribed and sworn to before me this ____ day of _____ 2023

NOTARY PUBLIC
My Commission Expires: _____

A JOINT VENTURE

BY: _____
(Name and Signature)

Doing Business as: _____

North Carolina Contractor Registration Number: _____

Business Address: _____

Phone Number: _____

Subscribed and sworn to before me this ____ day of _____ 2023

NOTARY PUBLIC
My Commission Expires: _____

(Each joint venturer must sign. The name of signing for each individual, partnership, and corporation that is a party to the joint venture should be in the manner indicated above.)

LIST OF SUBCONTRACTORS

In compliance with the Instructions to Bidders and the Supplementary Conditions, the undersigned submits the following names of Subcontractors to be used in performing the Work.

The Bidder certifies that all Subcontractors listed are eligible to perform the Work and that all Subcontractors performing more than five percent of the work are listed.

Subcontractor's Work	Subcontractor's Name	Amount of Bid
_____	_____	\$ _____
_____	_____	\$ _____
_____	_____	\$ _____
_____	_____	\$ _____
_____	_____	\$ _____

Bidder's Signature

BID BOND

This is a Bid Bond that is subject to the provisions of Article 3 of Chapter 44A of the North Carolina General statutes.

This Bond is executed on _____, 20 ____ .

The name of the PRINCIPAL is _____ (1)

_____ (2)

The name of the SURETY is _____

Fayetteville Public Works Commission, Fayetteville, North Carolina is the OWNER

The amount of the Bond is _____

_____ (Dollars) (\$ _____)

KNOW BY ALL MEN BY THESE PRESENTS, the Principal and Surety above named are hereby held and firmly bound unto the above named OWNER hereinafter called the OWNER in the penal sum of the amount stated above in lawful money of the United States, for the payment of which, well and truly to be made, we hereby jointly and severally bind ourselves, our heirs, executors, administrators, successors and assigns.

The condition of the above obligation is such that whereas the Principal has submitted to the OWNER a certain Bid, attached hereto and hereby made a part hereof to enter into a Contract in writing, for the construction of:

AST SYSTEM CONVERSION TO UST SYSTEM

NOW, THEREFORE

- (a) If said Bid shall be rejected, or in the alternate,
- (b) If said Bid shall be accepted and the Principal shall execute and deliver a Contract in the Form of Contract attached hereto (properly completed in accordance with said Bid) and shall furnish a bond for his faithful performance of said Contract, and for the payment of all persons performing labor or furnishing materials in connection therewith, and shall in all other respects perform the agreement created by the acceptance of said Bid, then this obligation shall be void, otherwise the same shall remain in force and effect; it being expressly understood and agreed that the liability of the Surety for any and all claims hereunder shall, in no event, exceed the penal amount of this obligation as herein stated.

The Surety, for value received, hereby stipulates and agrees that the obligations of said Surety and its Bond shall be in no way impaired or affected by any extension of the time within which the Owner may accept such Bid; and said Surety does hereby waive notice of any such extension.

IN WITNESS WHEREOF, the Principal and the Surety have hereunto set their hands and seals, and such of them as are corporations have caused their corporate seals to be hereto affixed and these presents to be signed by their proper officers, the day and year first set forth above.

ATTEST:

(Principal Secretary)
(SEAL)

Principal

BY: _____ (3)

(Address)

Witness as to Principal

Surety

(Address)

(Address)

ATTEST:

N.C. Resident Agent
(SEAL)

Witness as to Surety

(Address)

- (1) Correct name of Contractor
- (2) A Corporation, a Partnership or an Individual, as the case may be
- (3) If Contractor is a Partnership, all partners should execute Bond

**POWER OF ATTORNEY
(Attach)**

**AFFIDAVIT OF ORGANIZATION AND AUTHORITY SWORN STATEMENT
AST SYSTEM CONVERSION TO UST SYSTEM**

STATE OF _____

COUNTY OF _____

_____ being the first duly sworn on oath deposes and says that the Bidder on the attached Bid Form is organized as indicated below and that all statements herein made are made on behalf of such Bidder and that this deponent is authorized to make them.

(Fill Out Applicable Paragraph)

1. CORPORATION

The bidder is a corporation organized and existing under the laws of the State of _____ and its President is _____, and its Secretary is _____, and does have a corporate seal. The _____ is authorized to sign construction Contract and Bids for the company by action of its Board of Directors taken _____, a certified copy of which is hereto attached. (Strike out last sentence if not applicable.)

2. PARTNERSHIP

The Bidder is a Partnership consisting of _____ and _____, partners doing business under the name of _____.

3. SOLE TRADER

The Bidder is an individual and if operating under a trade name, such trade name is as follows:

4. ADDRESS

The business address of the Bidder is as follows:

Its phone number is _____

Bidder

By: _____

EQUAL EMPLOYMENT OPPORTUNITY

During the performance of this Contract the Contractor agrees as follows:

- a. The Contractor will not discriminate against any employee or applicant because of race, color, religion, sex, or national origin. The Contractor will take affirmative action to ensure that applicants are employed, and that employees are treated during employment, without regard to race, color, religion, sex, or national origin. Such action shall include but not be limited to the following: employment, upgrading, demotion, or transfer, recruitment or recruitment advertising, layoff or termination, rates of pay or other forms of compensation, and selection for training, including apprenticeship. The Contractor agrees to post in conspicuous places, available to employees and applicants for employment, notices setting forth the provisions of the nondiscrimination clause.
- b. The Contractor will, in all solicitations or advertisements for employees placed by or on behalf of the Contractor, state that all qualified applicants will receive consideration for employment without regard to race, color, religion, sex, or national origin.
- c. The Contractor will send to each labor union or representative of workers with which he has a collective bargaining agreement or other Contract understanding, a notice, to be provided, advising the labor union or worker's representative of the Contractor's commitments under the Equal Employment Opportunity Section of this Contract, and shall post copies of the notice in conspicuous places available to employees and applicants for employment.
- d. In the event of the Contractor's noncompliance with the nondiscrimination clauses of this Contract or with any of such rules, regulations, or orders, this Contract may be canceled, terminated, or suspended in whole or in part and the Contractor may be declared ineligible for further OWNER Contracts.
- e. The Contractor will include the provisions of this section in every subcontract or purchase order unless exempted by rules, regulations, or orders of the OWNER so that such provisions will be binding upon each Subcontractor or vendor.

(Use the following form for signatures by a CORPORATION):

Corporate Name

ATTEST:

(Assistant) Secretary

(Vice) President

(CORPORATE SEAL)

(Use the following form for signatures by and INDIVIDUAL):

BY: _____ (Seal)

WITNESS:

(ACKNOWLEDGEMENT OF THE ABOVE SIGNATURE MUST BE NOTARIZED USING FORM ON FOLLOWING PAGE)

NONDISCRIMINATION CLAUSE

It is specifically agreed as part of the consideration of the signing of this Contract that the parties hereto, their agents, officials, employees or servants will not discriminate in any manner on the basis of age, handicap, race, color, creed, sexual orientation or national origin with reference to the subject matter of this Contract, no matter how remote.

This provision being incorporated for the benefit of Fayetteville Public Works Commission, Fayetteville, North Carolina and its residents may be enforced as set out in said ordinances, enforcement of this provision shall be by action for specific performance, injunctive relief, or other remedy as by law provided.

This provision shall be binding on the successors and assigns of the parties hereto with reference to the subject matter of this Contract.

(Use the following form for signatures by a CORPORATION):

Corporate Name

ATTEST:

(Assistant) Secretary

BY: _____
(Vice) President

(Printed Name)

BY: _____
(Printed Name)

(Corporate Seal)

(Use the following form for signatures by a PARTNERSHIP or INDIVIDUAL):

BY: _____(SEAL)

(Printed Name)

WITNESS:

(Printed Name)

NON-COLLUSIVE AFFIDAVIT

State of _____)
_____)

County of _____)

_____ being first duly sworn,
deposes and says that:

- (1) He is the _____
(Owner, Partner, Officer, Representative or Agent)
of _____ the BIDDER that has
submitted the attached BID;
- (2) He is fully informed respecting the preparation and contents of the attached BID and of all
pertinent circumstances respecting such BID;
- (3) Such BID is genuine and is not a collusive or sham BID;
- (4) Neither the said BIDDER nor any of its officers, partners, Owners, agents, representatives,
employees or parties in interest, including this affiant, have in any way colluded, conspired,
connived or agreed, directly or indirectly, with any other BIDDER, firm, or person to submit
a collusive or sham BID in connection with the Contract for which the attached BID has
been submitted; or to refrain from bidding in connection with such Contract; or have in any
manner, directly or indirectly, sought by agreement or collusion, or communication, or
conference with any BIDDER, firm, or person to fix the price or prices in the attached BID
or of any other BIDDER, or to fix any overhead, profit, or cost elements of the BID price
or the BID price of any other BIDDER, or to secure through any collusion, conspiracy,
connivance, or unlawful agreement any advantage against (Recipient), or any person
interested in the proposed Contract;
- (5) The price or prices quoted in the attached BID are fair and proper and are not tainted by
any collusion, conspiracy, connivance, or unlawful agreement on the part of the BIDDER
or any other of its agents, representatives, Owners, employees or parties in interest,
including this affidavit.

BY _____

ITS _____
(Title)

Subscribed and sworn to before me this _____ day of _____, 20 ____ .

Notary Public

My Commission Expires:

END OF AFFIDAVIT

F.T.A. CERTIFICATION REGARDING LOBBYING

Certification for Contracts, Grants, Loans, and Cooperative Agreements

(To be submitted with each bid or offer exceeding \$100,000)

The undersigned _____ certifies, to the best of his or her knowledge and belief, that:

- (1) No federal appropriated funds have been paid or will be paid, by or on behalf of the undersigned, to any person for influencing or attempting to influence an officer or employee of an agency, a member of Congress, an officer or employee of Congress, or an employee of a member of Congress in connection with the awarding of any federal contract, the making of any federal grant, the making of any federal loan, the entering into of any cooperative agreement, and the extension, continuation, renewal, amendment, or modification of any federal contract, grant, loan, or cooperative agreement.
- (2) If any funds other than federal appropriated funds have been paid or will be paid to any person for making lobbying contacts to an officer or employee of any agency, a member of Congress, an officer or employee of Congress, or an employee of a member of Congress in connection with this federal contract, grant, loan, or cooperative agreement, the undersigned shall complete and submit Standard Form--LLL, "Disclosure Form to Report Lobbying," in accordance with its instructions [as amended by "Government wide Guidance for New Restrictions on Lobbying," 61 Fed. Reg. 1413 (1/19/96). Note: Language in paragraph (2) herein has been modified in accordance with Section 10 of the Lobbying Disclosure Act of 1995 (P.L. 104-65, to be codified at 2 U.S.C. 1601, *et seq.* .)]
- (3) The undersigned shall require that the language of this certification be included in the award documents for all subawards at all tiers (including subcontracts, subgrants, and contracts under grants, loans, and cooperative agreements) and that all subrecipients shall certify and disclose accordingly.

This certification is a material representation of fact upon which reliance was placed when this transaction was made or entered into. Submission of this certification is a prerequisite for making or entering into this transaction imposed by 31, U.S.C. § 1352 (as amended by the Lobbying Disclosure Act of 1995). Any person who fails to file the required certification shall be subject to a civil penalty of not less than \$10,000 and not more than \$100,000 for each such failure.

[Note: Pursuant to 31 U.S.C. § 1352(c)(1)-(2)(A), any person who makes a prohibited expenditure or fails to file or amend a required certification or disclosure form shall be subject to a civil penalty of not less than \$10,000 and not more than \$100,000 for each such expenditure or failure.]

The Contractor, _____, certifies or affirms the truthfulness and accuracy of each statement of its certification and disclosure, if any. In addition, the Contractor understands and agrees that the provisions of 31 U.S.C. A 3801, *et seq.*, *apply* to this certification and disclosure, if any.

_____ Signature of Contractor's Authorized Official

_____ Name and Title of Contractor's Authorized Official

_____ Date

**CERTIFICATION OF PRIMARY PARTICIPANT REGARDING DEBARMENT,
SUSPENSION AND OTHER RESPONSIBILITY MATTERS**

The Primary Participant, _____ (major third party contractor), certifies to the best of its knowledge and belief, that it and its principals:

1. Are not presently debarred, suspended, proposed for debarment, declared ineligible, or voluntarily excluded from covered transactions by any Federal department or agency;
2. Have not within a three-year period preceding this proposal been convicted of or had a civil judgment rendered against them for commission of fraud or a criminal offense in connection with obtaining, attempting to obtain, or performing a public (Federal, State or local) transaction or contract under a public transaction; violation of Federal or State antitrust statutes or commission of embezzlement, theft, forgery, bribery, falsification or destruction of records, making false statements, or receiving stolen property;
3. Are not presently indicted for or otherwise criminally or civilly charged by a governmental entity (Federal, State or local) with commission of any of the offenses enumerated in paragraph (2) of this certification; and
4. Have not within a three-year period preceding this application/proposal had one or more public transactions (Federal, State or local) terminated for cause or default.

(If the primary participant is unable to certify to any of the statements in this certification, the participant shall attach an explanation to this certification.)

THE PRIMARY PARTICIPANT _____ CERTIFIES OR AFFIRMS THE TRUTHFULNESS AND ACCURACY OF THE CONTENTS OF THE STATEMENTS SUBMITTED ON OR WITH THIS CERTIFICATION AND UNDERSTANDS THAT THE PROVISIONS OF 31 U.S.C. SECTIONS 3801 ET. SEQ. ARE APPLICABLE THERETO.

Signature

Title

Printed Name

Date



CITY OF FAYETTEVILLE

**SMALL DISADVANTAGED BUSINESS
ENTERPRISE PROGRAM
FOR
CONSTRUCTION, PROCUREMENT, AND
PROFESSIONAL SERVICES**

**FAYETTEVILLE CITY COUNCIL
433 HAY STREET
FAYETTEVILLE, NORTH CAROLINA 28301**

SMALL DISADVANTAGED BUSINESS ENTERPRISE PROGRAM

TABLE OF CONTENTS

	<u>Page</u>
I. Applicability	1
II. Definitions	1
III. SDBE Program Administration	4
IV. Race- and Gender-Neutral Measures to Ensure Equal Opportunities For All Bidders/Participants	5
V. SDBE Program Eligibility	6
VI. SDBE Goal Setting	7
VII. Counting Participation of SDBEs	7
VIII. Procurement of Architectural, Engineering and Surveying Services	8
IX. Informal Construction and Repair Work	8
X. Formal Construction and Repair Work	8
XI. Contract Performance Compliance Procedures	10
XII. Protest Procedure	12
XIII. Dispute Resolution.....	12
XIV. Penalties.....	12
XV. Program Review	13

SMALL DISADVANTAGED BUSINESS ENTERPRISE PROGRAM

I. Applicability.

(a) This program shall apply to all construction and repair work involving the expenditure of City funds, regardless of the sources of other funds, in the amounts set forth in G.S. 143-129 and G.S. 143-131; this program shall also apply to the procurement of architectural, engineering and surveying services as outlined in G.S. 143-64.31. This program shall not apply to contracts established by the State or any agency of the State.

(b) If any section, subsection, clause or provision of this chapter, including those groups found to be presumptively socially disadvantaged, is held to be invalid by a court of competent jurisdiction, the remainder of the chapter shall not be affected by such invalidity.

II. Definitions.

As used in this part, the following terms shall have the following meanings:

Affiliation - One firm controls or has the power to control the other, or a third party or parties controls or has the power to control both, or an identity of interests exists between such firms. In determining whether firms are Affiliates, the City shall consider all appropriate factors, including common ownership, common management, and contractual relationships. Affiliates must be considered together in determining whether a firm is a Small Business Enterprise.

Bidder/Participant - Any person, firm, partnership, corporation, limited liability company, association or joint venture seeking to be awarded a public contract or subcontract.

Brokering - Filling orders by purchasing or receiving supplies from a third party supplier rather than out of existing inventory, and providing no Commercially Useful Function other than acting as a conduit between a supplier and a customer.

City - The awarding authority for contracts awarded by the City of Fayetteville and the City of Fayetteville Public Works Commission.

City's Marketplace - The geographic and procurement areas in which the City contracts on an annual basis.

Commercially Useful Function - Responsibility for the execution of a distinct element of the work of the contract which is carried out by actually performing, managing, and supervising the work involved, or fulfilling responsibilities as a joint venture.

Contract - A mutually binding legal relationship or any modification thereof obligating the seller to furnish equipment or services and obligating the buyer to pay for them, not including leases or emergency procurements.

Doing Business - Having a physical location from which to engage in for profit activities in the scope(s) of expertise of the firm.

Economically Disadvantaged - An individual whose Personal Net Worth is less than the amount identified in 49 CFR Part 26

Equipment - Materials, supplies, commodities and apparatuses.

Expertise - Demonstrated skills, knowledge, or ability to perform in the field of endeavor in which certification is sought by the firm as defined by normal industry practices, including licensure where required.

Good Faith Efforts - Actions undertaken by a Bidder/Participant to achieve a SDBE goal which, by their scope, intensity, and appropriateness to the objective, can reasonably be expected to fulfill the Program's requirements.

Joint Venture - An association of two or more persons, or any combination of types of business enterprises and persons numbering two or more, proposing to perform a single for profit business enterprise, in which each joint venture partner contributes property, capital, efforts, skill and knowledge, and in which the SDBE is responsible for a distinct, clearly defined portion of the work of the contract and whose share in the capital contribution, control, management, risks, and profits of the joint venture is commensurate with its ownership interest. Joint ventures must have an agreement in writing specifying the terms and conditions of the relationships between the partners and their relationship and responsibility to the contract.

Managers - The City Manager.

Manufacturer - A firm that operates or maintains a factory or establishment that produces, on the premises, the materials, supplies, articles, or equipment required under the contract and of the general character described by the specifications.

Personal Net Worth - The net value of the assets of an individual after total liabilities are deducted. An individual's Personal Net Worth does not include the individual's ownership interest in an applicant or the individual's equity in his or her primary place of residence. An individual's Personal Net Worth includes only his or her share of assets held jointly with the individual's spouse.

Program - The SDBE Program.

Project Specific Goal - The Goal established for a particular project or contract based upon the availability of SDBEs in the scopes of work of the Contract.

Regular Dealer - A firm that owns, operates, or maintains a store, warehouse, or other establishment in which the materials, supplies, articles or equipment of the general character described by the specifications and required under the contract are bought, kept in stock, and regularly sold or leased to the public in the usual course of business. To be a Regular Dealer, the firm must be an established, regular business that engages, as its principal business and under its own name, in the purchase and sale or lease of the products in question. A firm may be a Regular Dealer in such bulk items as petroleum products, steel, cement, gravel, stone, or asphalt without owning, operating, or maintaining a place of business if the firm both owns and operates distribution equipment for the products. Any supplementing of a Regular Dealer's distribution equipment shall be by a long-term lease agreement and not on an *ad hoc* or contract-by-contract basis. Packagers, manufacture representatives, or other persons who arrange or expedite transactions are not Regular Dealers.

Schedule of Participation - The list of SDBEs that the Bidder/Participant commits will be utilized, their scopes of the work, and dollar value or the percentage of the project they will perform.

Socially Disadvantaged - An individual who has been subjected to racial or ethnic prejudice or cultural bias within American society because of his or her identity as a member of a group and without regard to individual qualities. Social disadvantage must stem from circumstances beyond the individual's control. A Socially Disadvantaged individual must be a citizen or lawfully admitted permanent resident of the United States who is either:

- (a) A person whose lifelong cultural and social affiliation is with one of the following groups, which are rebuttably presumed to be Socially Disadvantaged:
 - (i) Blacks/African - Americans (persons having origins in any of the Black racial groups of Africa);
 - (ii) Hispanic - Americans (persons of Mexican, Puerto Rican, Cuban, Dominican, Central or South American, or other Spanish or Portuguese culture or origin, regardless of race);

- (iii) Native - Americans (persons having origins in the original groups of North America);
 - (iv) Asian - Americans (persons having origins in any of the original groups of the Far East, Southeast Asia, the islands of the Pacific or the Indian Subcontinent);
 - (v) Women; or
- (b) Any socially disadvantaged individual as defined by 15 U.S.C. 637.

Small Disadvantaged Business Enterprise (SDBE) - Means a business, including a sole proprietorship, partnership, corporation, limited liability company, joint venture or any other business or professional entity:

- (a) Which is at least 51 percent owned by one or more Socially and Economically Disadvantaged individuals, or in the case of a publicly owned business, at least 51 percent of all classes of the stock of which is owned by one or more Socially and Economically Disadvantaged individuals;
- (b) Whose management, policies, major decisions and daily business operations are independently managed and controlled by one or more such Socially and Economically Disadvantaged individuals;
- (c) Which is a Small Business Enterprise as defined by 13 CFR Part 121;
- (d) Which is Doing Business in the City's Marketplace; and
- (e) Which is certified as a SDBE by the City of Fayetteville.

SDBE Program Coordinator - The person designated by the Managers to administer the Program.

III. SDBE Program Administration.

The Coordinator shall administer the SDBE Program, which duties shall include:

- (a) Formulating, proposing, and implementing rules and regulations for the further development, implementation, and monitoring of the Program.
- (b) Informing SDBEs of City contracting opportunities through outreach activities.
- (c) Providing information and assistance to SDBEs relating to City procurement practices and procedures, and bid specifications, requirements, and prerequisites.
- (d) Certifying businesses as SDBEs, maintaining certification records, and ensuring that all City departments have current certification listings.
- (e) Establishing Project Specific Goals.
- (f) Evaluating Bidder/Participant's achievement of Project Specific Goals or Good Faith Efforts to meet Project Specific Goals.
- (g) Working with City departments to monitor Contracts to ensure prompt payments to SDBEs, compliance with Project Specific Goals and commitments and the Program's operations and objectives.
- (h) Receiving, reviewing, and acting upon complaints and suggestions concerning the Program.

- (i) Collecting data to evaluate the Program.
- (j) Monitoring the Program and reporting to the Managers, the Mayor and the City Council on the administration and operations of the Program.

IV. Race- and Gender-Neutral Measures to Ensure Equal Opportunities for All Bidders/Participants.

The City shall develop and use measures to facilitate the participation of all firms in City contracting activities. These measures shall include, but are not limited to:

- (a) Arranging solicitation times for the presentations of bidding opportunities, which includes quantities, specifications and delivery schedules so as to facilitate the participation of interested firms.
- (b) Dividing requests for bids or proposals into work elements to facilitate the participation of small firms.
- (c) Providing timely information on specific contracting opportunities, contracting procedures, and bid preparation.
- (d) Holding pre-bid conferences, where appropriate, to explain the projects.
- (e) Enforcing prompt payment requirements and procedures, including requiring by contract that prime contractors promptly pay subcontractors.
- (f) Reviewing bonding and insurance requirements to eliminate unnecessary barriers to contracting with the City.
- (g) Maintaining information on all firms bidding on City prime contracts and subcontracts.

V. SDBE Program Eligibility.

- (a) Only businesses that meet the criteria of SDBEs may participate in the Program.
- (b) The City shall apply the certification criteria and procedures of 49 CFR Part 26 to applicants for participation in the Program.
- (c) The City shall certify the eligibility of joint ventures involving SDBEs and non-SDBEs.
- (d) In lieu of conducting its own certifications, the Coordinator may accept formal certifications by other entities as meeting the requirements of the Program, if the eligibility standards of such entities are comparable to those of the City. Certification decisions, including decertification and graduation determinations, by those other entities shall be accepted by the City in its discretion.
- (e) It is the responsibility of the SDBE to notify the Coordinator of any change in its circumstances affecting its continued eligibility for the Program. Failure to do so may result in the firm's decertification.
- (f) A SDBE may be decertified if it submitted inaccurate, false, or incomplete information to the City or failed to comply with requirements of a contract with the City or with the requirements of the Program.
- (g) A third party may challenge the eligibility of a certified firm:
 - (1) The challenge shall be made in writing under oath and shall include all information relied upon by the challenging party.

- (2) The Coordinator shall provide an opportunity to the parties for an informal hearing. The parties may appear and provide documentation or other evidence and be represented by counsel.
 - (3) The Coordinator shall render a written decision within 15 days of the hearing.
 - (4) If the Coordinator determines that the firm is not eligible, it may appeal the determination to the Manager in writing within 7 days of receipt of the written decision. The challenging party shall have no right of appeal from the Coordinator's determination.
 - (5) The Manager shall issue a written decision within 15 days of receipt of the appeal. The Manager's determination shall be final.
- (h) A firm that has been decertified may not reapply for certification for one year from the effective date of its decertification.

VI. SDBE Goal Setting.

The Coordinator shall establish a Project Specific Goal for appropriate Contracts based on normal industry practice as determined in consultation with the appropriate Department, the availability of SDBEs to perform the functions of the Contracts and the City's utilization of SDBEs to date.

VII. Counting Participation of SDBEs.

(a) The entire amount of that portion of a construction Contract that is performed by the SDBE's own forces shall be counted, including the cost of equipment obtained by the SDBE for the work of the Contract, and equipment purchased or leased by the SDBE (except equipment the SDBE subcontractor or Joint Venture partner purchases or leases from the prime contractor or its Affiliate).

(b) The entire amount of fees or commissions charged by a SDBE for providing a *bona fide* service, such as professional, technical, consultant or managerial services, or for providing bonds or insurance specifically required for the performance of the Contract, shall be counted, provided the fee is reasonable and not excessive as compared with fees customarily charged for similar services.

(c) When a SDBE performs as a participant in a Joint Venture, only the portion of the total dollar value of the Contract equal to the distinct, clearly defined portion of the work of the Joint Venture's Contract that the SDBE performs with its own forces and for which it is separately at risk shall be counted.

(d) Only expenditures to a SDBE that is performing a Commercially Useful Function shall be counted. To determine whether a firm is performing a Commercially Useful Function, the City will evaluate the amount of work subcontracted, industry practices, whether the amount the firm is to be paid under the Contract is commensurate with the work it is actually performing and other relevant factors. To perform a Commercially Useful Function, the SDBE must be responsible, with respect to equipment used on the Contract, for negotiating price, determining quality and quantity, ordering the material, installing (where applicable) and paying for the material itself. A SDBE does not perform a Commercially Useful Function if its role is limited to that of an extra participant in the Contract through which funds are passed in order to obtain the appearance of SDBE participation. If a SDBE subcontracts a greater portion of the work of a Contract than would be expected on the basis of normal industry practice, it is presumed not to perform a Commercially Useful Function. When a SDBE is presumed not to be performing a Commercially Useful Function, the SDBE may present evidence to rebut this presumption.

(e) One hundred percent of the cost of the materials or supplies obtained from a SDBE Manufacturer or Regular Dealer shall be counted. One hundred percent of the fees or transportation charges for the delivery of materials or supplies required on a job site shall be counted only if the payment of such fees is a customary industry

practice and are commensurate with fees customarily charged for similar services. The cost of the materials and supplies shall not be counted.

(f) If a firm is decertified during performance of a Contract, the dollar value of work performed under a Contract with that firm after it has been decertified shall not be counted.

(g) In determining achievement of a Project Specific Goal, the participation of a SDBE shall not be counted until that amount has been paid to the SDBE.

VIII. Procurement of Architectural, Engineering and Surveying Services (G.S. 143-64.31)

(a) The City shall use good faith efforts to notify minority firms of the opportunity to submit qualifications for architectural, engineering, surveying and construction management at risk services.

IX. Informal Construction and Repair Work (G.S. 143-131)

(a) The City shall solicit minority participation for construction and repair projects in the amount of five thousand dollars (\$5,000) or more, but less than three hundred thousand dollars (\$300,000). The City shall maintain a record of contractors solicited and shall document efforts to recruit minority business participation in these contracts.

X. Formal Construction and Repair Work (G.S. 143-129)

(a) For all solicitations, the Bidder/Participant shall submit a Schedule of Participation detailing all subcontractors from which the Bidder/Participant solicited bids or quotations, and if a Project Specific Goal has been established, its achievement of the Goal or its Good Faith Efforts to do so. The list of SDBEs provided by the City to a Bidder/Participant establishes the minimum universe from which a Bidder/Participant must solicit SDBEs. The Schedule of Participation shall be due at the time set out in the solicitation documents.

(b) Any agreement between a Bidder/Participant and a SDBE in which the Bidder/Participant requires that the SDBE not provide subcontracting quotations to other bidders/proposers is prohibited.

(c) SDBEs shall respond to relevant requests for quotations.

(d) Where the Bidder/Participant cannot achieve the Project Specific Goal, the Coordinator will determine whether the Bidder/Participant has made Good Faith Efforts. At a minimum, the Bidder/Participant must engage in the following Good Faith Efforts that total at least 50 points for the bid or proposal to be responsive.

(1) Contacting SDBEs from the list provided by the City at least ten days before the bid or proposal date and notifying them of the nature and scope of the work to be performed. The Bidder/Participant shall provide interested SDBEs with timely, adequate information about the plans, specifications, and requirements of the Contract to allow SDBEs to respond to the solicitation. The Bidder/Participant must follow up initial solicitations with interested SDBEs. 10 points.

(2) Providing or making the construction plans, specifications, and requirements available for review by SDBEs at least ten days before the bid or proposals are due. 10 points.

(3) Breaking down or combining elements of work into economically feasible units to facilitate minority participation. 15 points.

(4) Working with SDBE, minority, women, trade, community or contractor organizations identified by the City in the bid documents that provide assistance in recruitment of SDBEs. 10 points.

(5) Attending any prebid meetings scheduled by the City. 10 points.

- (6) Providing assistance in getting required bonding or insurance or providing alternatives to bonding or insurance for subcontractors. 20 points.
- (7) Negotiating in good faith with interested SDBEs and not rejecting them as unqualified without sound reasons based on their capabilities. Evidence of such negotiation includes the names, addresses, and telephone numbers of SDBEs that were contacted; a description of the information provided regarding the plans and specifications for the work selected for subcontracting; and why agreements could not be reached with SDBEs. The Bidder/Participant may not reject SDBEs as being unqualified without sound reasons based on a thorough investigation of their capabilities. Any rejection of a SDBE based on price or lack of qualifications must be documented in writing. 15 points.
- (8) Providing assistance to an otherwise qualified SDBE in need of equipment, loan capital, lines of credit, or joint pay agreements to secure loans, supplies, or letters of credit, including waiving credit that is ordinarily required. Assisting SDBEs in obtaining the same unit pricing with the bidder's suppliers in order to help minority SDBEs to establish credit. 25 points.
- (9) Negotiating joint venture and partnership arrangements with SDBEs to increase opportunities for SDBE participation. 20 points.
- (10) Providing quick pay agreements and policies to enable SDBEs to meet cash-flow demands. 20 points.

(e) In determining whether a Bidder/Participant has made Good Faith Efforts, the performance of other bidders/proposers in meeting the Project Specific Goal may be considered. For example, when the apparent successful Bidder/Participant fails to meet the Project Specific Goal but others meet it, it may be reasonably questioned whether, with additional reasonable efforts, the apparent successful Bidder/Participant could have met the Goal. Similarly, if the apparent successful Bidder/Participant fails to meet the Goal, but meets or exceeds the average SDBE participation obtained by other bidders/proposers, this may be evidence that the apparent successful Bidder/Participant made Good Faith Efforts.

(f) The Coordinator shall timely review the Schedule of Participation prior to award, including the scope of work and the letters of intent from SDBEs. The Coordinator may request clarification in writing of items listed in the Schedule of Participation, provided such clarification shall not include the opportunity to augment listed SDBE participation or Good Faith Efforts.

(g) The Schedule of Participation and supporting documents shall be reviewed by a Bid Selection Committee, composed of the operating departments, Purchasing Department, Coordinator and other representatives as appropriate. If the Bid Selection Committee initially determines the bid to be responsive, it shall recommend award of the Contract to the Managers. If the Bid Selection Committee determines the bid to be non-responsive, it shall confer with the City Attorney prior to recommending the rejection of the bid.

(h) A Bidder/Participant found to be non-responsive may appeal this determination pursuant to the City's bid protest procedures.

XI. Contract Performance Compliance Procedures.

(a) Upon award of a Contract by the City that includes a Project Specific Goal, the Goal becomes a covenant of performance by the Bidder/Participant in favor of the City.

(b) The Bidder/Participant shall provide a listing of all subcontractors to be used in the performance of the Contract, and subcontractor payment information to the City with each request for payment submitted to the City. The Coordinator and the operating department shall monitor subcontractor participation during the course of the Contract and shall have reasonable access to all Contract-related documentation held by the Bidder/Participant. The Bidder/Participant shall submit reports at such times and in such formats as requested by the City.

- (c) The Bidder/Participant shall cooperate with the City in studies and surveys related to the Program.
- (d) The Bidder/Participant cannot make changes to the Schedule of Participation or substitute subcontractors named in the Schedule of Participation without the prior written approval of the Coordinator. Unauthorized changes or substitutions shall be a violation of this program, and may constitute grounds for rejection of the bid or proposal or cause termination of the executed Contract for breach, the withholding of payment and/or subject the Bidder/Participant to Contract penalties or other sanctions.
- (1) All requests for changes or substitutions of the subcontractors named in the Schedule of Participation shall be made to the Coordinator in writing, and shall clearly and fully set forth the basis for the request. A Bidder/Participant shall not substitute a subcontractor or perform the work designated for a subcontractor with its own forces unless and until the Coordinator approves such substitution in writing.
- (2) The facts supporting the request must not have been known nor reasonably should have been known by either party prior to the submission of the Schedule of Participation. Bid shopping is prohibited.
- (3) Substitutions of the subcontractor shall be permitted only on the following basis:
- (i) Unavailability after receipt of reasonable notice to proceed.
 - (ii) Failure of performance.
 - (iii) Financial incapacity.
 - (iv) Refusal by the subcontractor to honor the bid or proposal price.
 - (v) Mistake of fact or law about the elements of the scope of work of a solicitation where agreement upon a reasonable price cannot be reached.
 - (vi) Failure of the subcontractor to meet insurance, licensing, or bonding requirements; or
 - (vii) The subcontractor's withdrawal of its bid or proposal.
- (4) Where the Bidder/Participant has established the basis for the substitution to the satisfaction of the Coordinator, the Bidder/Participant shall make Good Faith Efforts to fulfill the Schedule of Participation if the Project Specific Goals will not otherwise be met. The Bidder/Participant may seek the assistance of the SDBE Office in obtaining a new SDBE subcontractor. If the Project Specific Goal cannot be reached and Good Faith Efforts have been made, the Bidder/Participant may substitute with a non-SDBE.
- (e) If a Bidder/Participant plans to hire a subcontractor on any scope of work that was not previously disclosed in the Schedule of Participation, the Bidder/Participant shall obtain the approval of the Coordinator to modify the Schedule of Participation and must make Good Faith Efforts to ensure that SDBEs have a fair opportunity to bid on the new scope of work.
- (f) The SDBE Compliance Committee, comprised of the Coordinator as the Chair and a representative from the Purchasing Department or any requested representative, shall be responsible for evaluating and reviewing issues and concerns concerning the Program, including whether a Bidder has complied with the Good Faith Efforts.
- (g) If the Bidder/Participant is found to be in noncompliance with the Program or the Contract and fails to correct such noncompliance within ten working days after written notification, the City will withhold 5

percent of the amount of completed work on all monthly payments until the Bidder/Participant has come into compliance.

XII. Protest Procedure.

A Bidder/Participant may protest a decision regarding the implementation of the Program, including the determination that it has not made Good Faith Efforts, by filing a written grievance with supporting evidence with the Coordinator. The Coordinator shall provide a written response within ten working days of receipt of the grievance. The Bidder/Participant may appeal the Coordinator's determination in writing within ten working days of receipt to the Purchasing Director. The Director shall refer the grievance to the SDBE Compliance Committee, which shall hold a hearing and issue a written recommendation within ten working days. The Manager, upon receipt of the SDBE Compliance Committee's recommendation, shall make a final determination within ten working days.

XIII. Dispute Resolution.

Notwithstanding the protest procedures outlined above, mediation shall be required for all parties involved in a dispute under this program prior to initiating litigation concerning the dispute. The procedures for mediation shall be those adopted by City Council Resolution #2002-066 which is incorporated herein by reference as if fully set forth herein.

XIV. Penalties.

(a) Providing false or misleading information to the City in connection with an application for or challenge to certification, recertification or decertification as a SDBE, submission of a bid, responses to requests for qualifications or proposals, Good Faith Efforts documentation, post-award compliance, or other actions in violation of this program may render any bid award or contract void. A contract that is void under this section may continue in effect until an alternative can be arranged when immediate termination would result in harm to the public health or welfare.

(b) A Bidder/Participant is subject to withholding of payments under the Contract, termination of the Contract for breach, Contract penalties, decertification as a SBDE, or being barred or deemed non-responsive in future City solicitations and Contracts for up to two years, if it is found to have:

- (1) Provided false or misleading information in connection with the submission of a bid or proposal or documentation of Good Faith Efforts, post-award compliance, or other Program operations.
- (2) Failed in bad faith to fulfill the Project Specific Goal, thereby materially breaching the Contract.
- (4) Repeatedly failed to comply in good faith with substantive provisions of this program.

(c) The City reserves the right to pursue all remedies available in law or in equity for violations of this program.

XV. Program Review.

(a) The Managers, the Mayor, and the City Council shall receive an annual report from the Coordinator detailing the City's performance under the Program.

(b) The Managers, the Mayor, and the City Council will review this report, including the City's progress towards eliminating discrimination in its contracting activities and marketplace, and revise the Program as necessary to meet legal and Program requirements.

(c) If the Managers, the Mayor, and the City Council find that the objectives of the Program have been achieved, the City Council shall sunset the Program.

**CITY OF FAYETTEVILLE
AND
FAYETTEVILLE PUBLIC WORKS COMMISSION
SDBE/HUB COMPLIANCE PROVISIONS**

SDBE/HUB CONTRACT PROVISIONS

APPLICATION:

The requirements of the Small Disadvantaged Business Enterprise Program (“SDBE”) for participation in the City of Fayetteville’s construction contracts are hereby made a part of the Contract Documents. These requirements shall apply to all contracts regardless of ownership. Copies of the SDBE may be obtained from:

Fayetteville Public Works Commission
Procurement Department/Trent Ensley
P.O. Box 1089 Fayetteville, North Carolina 28302
Phone (910) 223-4333 Fax (910) 483-1429 e-mail: trent.ensley@faypwc.com

NCDOT DBE Directory: www.ebs.nc.gov/VendorDirectory
HUB Directory <https://ncadmin.nc.gov/businesses/hub>

SDBE COMPLIANCE REQUIREMENTS

1. The Bidder shall provide **with the Bid** the properly executed SDBE documents identified below, which signifies that the Bidder understands and agrees to the incorporated SDBE requirements and provisions.
2. The Bidder shall provide **with the bid:**

Provided with Bid Form Proposal

Identification of SDBE/HUB Participation Form
AND
Affidavit A: Listing of Good Faith Efforts

OR

Identification of SDBE/HUB Participation Form
AND
Affidavit B: Intent to Self-Perform with Own Workforce

Provided upon being presented with Notice of Award

Affidavit C: Percentage of SDBE/HUB Participation
OR
Affidavit D: Good Faith Efforts

All written statements, certifications, or intentions made by the Bidder shall become a part of the Agreement between the Contractor and the City of Fayetteville, by and through the Fayetteville Public Works Commission (“PWC”) for performance of the Work. Failure to comply with any of these statements, certifications, intentions, or the SDBE compliance provisions shall constitute a breach of contract. Any such breach may result in termination of the Agreement in accordance with the termination provisions contained in the Contract Documents.

SUBCONTRACTOR PAYMENT REQUIREMENTS:

North Carolina General Statutes (“NCGS”) 143-134.1 states that the percentage of retainage on payments made by the prime contractor to the subcontractor shall not exceed the percentage of retainage on payments made by PWC to the prime contractor. Failure to comply with this provision shall be considered a breach of contract, and the Agreement may be terminated in accordance with the termination provisions of the Contract Documents.

The Contractor shall provide an itemized statement of payments to each SDBE subcontractor before final payment is processed.

The Contractor shall provide an itemized statement of payments to each non-SDBE subcontractor before final payment is processed.

Date: _____

(Name of Company)

(Signature)

Attest: _____
(Above Name Typed or Printed)

(Title)

Affidavit A: Listing of the Good Faith Efforts

Affidavit of _____
(Name of Bidder)

I have made a good faith effort to comply under the following areas checked:
(A minimum of 50 value points must be checked in order to have achieved a "good faith effort")

- (1) Contacting minority businesses that reasonably could have been expected to submit a quote and that were known to the contractor or available on State or local government maintained lists at least 10 days before the bid or proposal date and notifying them of the nature and scope of the work to be performed. Value = Ten (10) points.
- (2) Making the construction plans, specifications and requirements available for review by prospective minority businesses, or providing these documents to them at least 10 days before the bid or proposals are due. Value = Ten (10) points.
- (3) Breaking down or combining elements of work into economically feasible units to facilitate minority participation. Value = Fifteen (15) points.
- (4) Working with minority trade, community, or contractor organizations identified by the Office for Historically Underutilized Businesses and included in the bid documents that provide assistance in recruitment of minority businesses. Value = Ten (10) points.
- (5) Attending any pre-bid meetings scheduled by the public owner. Value = Ten (10) points.
- (6) Providing assistance in getting required bonding or insurance or providing alternatives to bonding or insurance for subcontractors. Value = Twenty (20) points.
- (7) Negotiating in good faith with interested minority businesses and not rejecting them as unqualified without sound reasons based on their capabilities. Any rejection of a minority business based on lack of qualification should have the reasons documented in writing. Value = Fifteen (15) points.
- (8) Providing assistance to an otherwise qualified minority business in need of equipment, loan capital, lines of credit, or joint pay agreements to secure loans, supplies, or letters of credit, including waiving credit that is ordinarily required. Assisting minority businesses in obtaining the same unit pricing with the bidder's suppliers in order to help minority businesses in establishing credit. Value = Twenty-five (25) points.
- (9) Negotiating joint venture and partnership arrangements with minority businesses in order to increase opportunities for minority business participation on a public construction or repair project when possible. Value = Twenty (20) points.
- (10) Providing quick pay agreements and policies to enable minority contractors and suppliers to meet cash-flow demands. Value = Twenty (20) points.

In accordance with NCGS 143-128.2(d) the undersigned will enter into a formal agreement with the firms listed in the Identification of Small Disadvantaged Business Participation schedule conditional upon execution of a contract with PWC. Failure to abide by this statutory provision will constitute a breach of contract. The undersigned hereby certifies that he or she has read the terms of the SDBE commitment and is authorized to bind the Bidder to the commitment herein set forth.

Date: _____ Name of Authorized Officer: _____

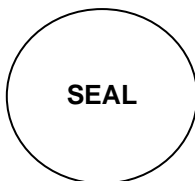

State of North Carolina, County of _____
Subscribed and sworn to before me this _____ day of _____ 20____
Notary Public _____
My commission expires _____

Affidavit B: Intent to Perform Contract with Own Workforce

Affidavit of _____
(Name of Bidder)

I hereby certify that it is our intent to perform 100% of the work required for the following Project: _____

In making this certification, the Bidder states that the Bidder does not customarily subcontract elements of this type Project; normally performs, has the capability to perform, and will perform **all elements of the Work** on this Project with his/her own current work forces; and will complete all elements of the Project **without** the use of subcontractors, material suppliers, or providers of professional services.

The Bidder agrees to provide any additional information or documentation requested by PWC in support of the above statement.

The undersigned hereby certifies that he or she has read this certification and is authorized to bind the Bidder to the commitments herein contained.

Date: _____ Name of Authorized Officer: _____

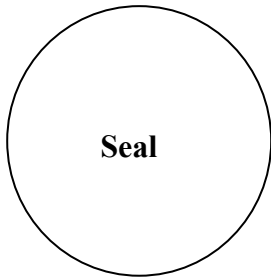

Signature: _____

Title: _____

State of North Carolina, County of _____
Subscribed and sworn to before me this ____ day of ____ 20__
Notary Public _____
My commission expires _____

THIS FORM IS NOT TO BE SUBMITTED WITH THE BID PROPOSAL

Affidavit C: Percentage of SDBE/HUB Participation

If the portion of the work to be executed by SDBE/HUB as defined in NCGS 143-128.2(g) is **equal to or greater than 10% of the Bidders total Contract Price**, then the Bidder must complete this affidavit. This affidavit shall be provided by the apparent lowest responsible, responsive Bidder within **72 hours** after notification of being low Bidder.

Affidavit of _____ . I do certify that on the
(Name of Company)

\$

(Project Number)

(Dollar Amount of Total Bid)

I will expend a minimum of _____% of the total dollar amount of the Contract Price with small disadvantaged business enterprises. Such companies or individuals will be employed as subcontractors, vendors, or providers of professional services. Such work will be subcontracted to the following firms listed below.

Name, Address and Phone No.	*SDBE HUB Category	Description	Dollar Value	% of Contract

*SDBE categories: Black-African Americans (B), Hispanic-Americans (H), Asian- Americans (A), Native-Americans (I), Women (F), Socially/Economically Disadvantaged (D)

*HUB Statewide Uniform Certification (SWUC)

Pursuant to NCGS 143-128.2(d), the undersigned will enter into a formal agreement with small disadvantaged firms for work listed in this schedule conditional upon execution of a contract with PWC. Failure to fulfill this commitment may constitute a breach of contract.

The undersigned hereby certifies that he or she has read the terms of this commitment and is authorized to bind the Bidder to the commitment herein set forth.

Date: _____ Name of Authorized Officer: _____

Signature: _____

Title: _____

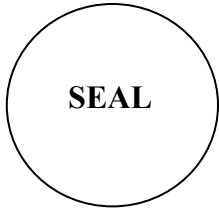

State of North Carolina, County of _____
Subscribed and sworn to before me this ____ day of ____ 20__
Notary Public _____
My commission expires _____

THIS FORM IS NOT TO BE SUBMITTED WITH THE BID PROPOSAL

Affidavit D: Good-Faith Efforts

If the goal of 10% participation by small disadvantaged businesses **is not** achieved, the Bidder shall provide the following documentation to PWC of good faith efforts.

Name, Address and Phone No.	*SDBE/HUB Category	Description	Dollar Value

*SDBE categories: Black-African Americans (B), Hispanic-Americans (H), Asian- Americans (A), Native-Americans (I), Women (F), Socially/Economically Disadvantaged (D)

*HUB Statewide Uniform Certification (SWUC)

Documentation of the Bidder’s good-faith efforts to meet the goals set forth in these provisions. Examples of documentation shall include the following evidence:

- A. Copies of solicitations for quotes to small disadvantaged business firms. Each solicitation shall contain a specific description of the work to be subcontracted, location where bid documents can be reviewed, representative of the Prime Bidder to contact, and location, date and time when quotes must be received.
- B. Copies of quotes or responses received from each firm responding to the solicitation.
- C. A telephone log of follow-up calls to each firm sent a solicitation.
- D. For subcontracts where a small disadvantaged business firm is not considered the lowest responsible sub-bidder, copies of quotes received from all firms submitting quotes for that particular subcontract.
- E. Documentation of any contacts or correspondence to small disadvantaged businesses, community or contractor organizations in an attempt to meet the goal.
- F. Copy of pre-bid roster.
- G. Letter documenting efforts to provide assistance in obtaining required bonding or insurance for small disadvantaged businesses.
- H. Letter detailing reasons for rejection of a small disadvantaged business due to lack of qualification.
- I. Letter documenting proposed assistance offered to small disadvantaged businesses in need of equipment, loan capital, lines of credit, or joint pay agreements to secure loans, supplies, or letter of credit, including waiving credit that is ordinarily required.

Failure to provide the documentation as listed in these provisions may result in rejection of the Bid and award to the next lowest responsible and responsive Bidder.

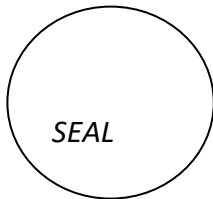

Date: _____ Name of Authorized Officer: _____

Signature: _____

Title: _____

State of North Carolina, County of _____

Subscribed and sworn to before me this _____ day of _____ 20__

Notary Public _____

My commission expires _____

THIS FORM IS NOT TO BE SUBMITTED WITH THE BID PROPOSAL

Affidavit E: SDBE/HUB Contract Payments:

Contractor: _____
Phone: _____
Address: _____
Project Name: _____
Pay Application #: _____ Period: _____

The following is a list of payments to be made to small disadvantaged business enterprises on the Project for the above-referenced period:

Firm Name and Address	*SDBE/HUB Category	Payment Amount	Owner Use Only

*SDBE categories: Black-African Americans (B), Hispanic-Americans (H), Asian- Americans (A), Native-Americans (I), Women (F), Socially/Economically Disadvantaged (D)
*HUB Statewide Uniform Certification (SWUC)

Date: _____ Approved/Certified By: _____
Name
Title
Signature

****SUBCONTRACTOR DOCUMENTS:
MUST BE SUBMITTED WITH EACH PAY REQUEST & FINAL PAYMENT**
Attach to Bid Attach to Bid Attach to Bid Attach to Bid Attach to Bid**

Identification of Small Disadvantaged Business Participation

I, _____ (Name of Bidder)
do hereby certify that for the Project, we will use the following small disadvantaged business enterprises as construction subcontractors, vendors, suppliers, or providers of professional services:

Firm Name, Address and Phone No.	Description	*SDBE/HUB Category

*SDBE categories: Black-African Americans (B), Hispanic-Americans (H), Asian- Americans (A),
Native-Americans (I), Women (F), Socially/Economically Disadvantaged (D)
*HUB Statewide Uniform Certification (SWUC)

The total value of small disadvantaged business contracting will be (\$) _____.

THIS FORM IS NOT TO BE SUBMITTED WITH THE BID PROPOSAL

Fayetteville Public Works Commission
Subcontractor Disclosure Form: Non-SDBE/HUB Documentation for Payments

Contractor: _____
Phone: _____
Address: _____
Project Name: _____
Pay Application #: _____ Period: _____

The following is a list of payments to be made to subcontractors on this project for the above-mentioned period.

Firm Name and Address	Payment Amount	Owner Use Only

Date: _____

Submitted By: _____

Name

Title

Signature

****SUBCONTRACTOR DOCUMENTS:
MUST BE SUBMITTED WITH EACH PAY REQUEST & FINAL PAYMENT****

NOTICE OF AWARD

TO: _____

PROJECT DESCRIPTION: AST SYSTEM CONVERSION TO UST SYSTEM

The OWNER has considered the BID submitted by you for the above described work in response to its Advertisement for Bids dated _____ and Instructions to Bidders.

You are hereby notified that your BID has been accepted for items in the amount of \$_____.

You are required by the Instructions to Bidders to execute the Agreement and furnish the required Performance Bond, Payment Bond, and Certificates of Insurance within ten (10) calendar days from the date of this NOTICE to you.

If you fail to execute said Agreement and to furnish said Bonds within ten (10) days from the date of this Notice, said Owner will be entitled to consider all your rights arising out of the OWNER's acceptance of your BID as abandoned and as a forfeiture of your Bid Bond. The Owner will be entitled to such other rights as may be granted by law.

You are required to return an acknowledged copy of this NOTICE OF AWARD to the OWNER.

Dated this _____ day of _____, 2023.

**OWNER: FAYETTEVILLE PUBLIC WORKS COMMISSION
FAYETTEVILLE, NC**

**BY: Tanga Anderson-Solomon
TITLE: Procurement Manager**

ACCEPTANCE OF AWARD

AST SYSTEM CONVERSION TO UST SYSTEM

Receipt of the preceding NOTICE OF AWARD is hereby acknowledged this the _____
day of _____, 2023.

(CONTRACTOR)

By: _____

Title: _____

- END OF SECTION -

State of North Carolina
Cumberland County

CONSTRUCTION AGREEMENT

THIS CONSTRUCTION AGREEMENT (“Agreement”) is made by and between the City of Fayetteville (the “City”), by and through Fayetteville Public Works Commission (“PWC”), a North Carolina public authority, and [REDACTED] (“Contractor”), a [REDACTED] (*specify type of legal entity, state of formation, and if not formed in NC, confirm NC registration to do business*) (each of each of PWC and Contractor is a “Party” and both are collectively the “Parties”) as of the date of execution last written below (the “Effective Date”). The Parties agree as follows:

1. The Construction Project. Contractor shall furnish and bear solely the entire cost of all labor and materials necessary for the construction and/or renovation of the Project (defined hereinbelow) as specified in the Contract Documents (defined hereinbelow) and complete all Work on the Project in a workmanlike manner in strict accordance with the Contract Documents, schedule delivery of the new materials, furnish and bear solely the entire cost of all supervision, contract administration, equipment, tools, and other means necessary to complete the Project, perform every obligation imposed by the Contract Documents, and be solely responsible for the clean-up and disposal of all materials and debris relating to or arising from the construction and renovation, subject to any exceptions that are specifically set forth in the Contract Documents. Except as otherwise specifically provided in the Contract Documents, Contractor is solely responsible for all construction means, methods, techniques, sequences, procedures, safety precautions or programs, supervising, coordinating, and performing all the Work necessary to complete the Project; provided, however, PWC shall have the right, without incurring any liability to the Contractor, to suspend Contractor’s performance when a PWC employee, in his or her opinion, observes a safety violation involving a threat to life or imminent danger of bodily injury, and the suspension shall remain in effect until Contractor remedies the safety violation.

2. Terms. Capitalized terms used in this Agreement have the meaning specified below:

“Business Day” means each calendar day that is not a Saturday, Sunday, holiday observed by the federal government for its employees, or holiday observed by the State of North Carolina for its employees.

“Completion of the Project” means: (i) the Project is completed in accordance with this Agreement, except for punch list items; (ii) PWC has received any required temporary or final certificate of occupancy from the governmental agency with jurisdiction over the Project; and (iii) the registered architects or engineers (the “Designer(s)”) who designed portions or components of the Project have issued certificates of Completion of the Project as to those portions or components.

“Contract Documents” means the following documents that were either made available to Contractor by PWC during the bid solicitation process (including Drawings) or executed by the Parties or both, which are all incorporated by reference herein:

- a. This Agreement
- b. Instructions to Bidders

- c. Bid Forms, including but not limited to Bid Form, Bid Summary, and Bidder Agreement
- d. Bid Schedule - Performance and Delivery
- e. Notice of Award
- f. Acceptance of Award
- g. Certificates of Insurance
- h. Notice to Proceed and Acceptance
- i. Definitions
- j. PWC General Conditions
- k. Exhibits

The following documents may be delivered or issued on or after the Effective Date of the Agreement and may not be attached to this Agreement, but are considered Contract Documents when executed by the Parties:

- l. Notice to Proceed and Acceptance of Notice
- m. Work Change Directive(s)
- n. Change Order(s)
- o. Field Order(s)

There are no Contract Documents other than those identified in this Agreement. The Contract Documents may only be amended, modified, or supplemented as provided in this Agreement in a writing signed by the Parties.

“Fault” means a breach of contract by Contractor, negligent, reckless, or intentional act(s) or omission(s) constituting a tort under applicable statutes or common law by one or more Responsible Persons, or violation(s) of applicable statute(s) or regulation(s) by a Responsible Person.

“Project” means (insert general description), as more specifically set forth in the Contract Documents.

“Responsible Person” means the Contractor and each of its employees, agents, representatives, subcontractors, or other persons and entities for which Contractor may be liable or responsible as a result of any statutory, tort, or contractual duty.

The terms used in this Agreement shall have the meaning as stated herein and in the Definitions and Terminology. In the event of a conflict between the terms of this Agreement and any other component(s) of the Contract Documents, the terms of this Agreement shall govern.

3. Contract Price. PWC shall pay Contractor for Completion of the Project in accordance with the Contract Documents the amount identified in the accepted Bid Form of Contractor, being in the total amount of \$_____ (the “Price”). Contractor understands and acknowledges that the Price is derived from a specific appropriation of funds provided for the Project. Contractor agrees and acknowledges the Price is equal to the aggregate cost of all Work to be done on the Project, including all labor, materials, equipment, apparatus, and supplies, set in accordance with the amount specified on the Bid Form submitted by Contractor and accepted by PWC.

4. Contract Times. The Parties shall perform their obligations under this Agreement

in compliance with all scheduling deadlines set forth in the Contract Documents. The Contractor shall commence the Work to be performed under this Agreement on a date to be specified in accordance with the Notice to Proceed issued by PWC. Contractor shall achieve Completion of the Project no later than [REDACTED], plus any modifications thereof allowed in accordance with the PWC General Conditions (the "Completion Date").

5. Payment. PWC shall pay Contractor in installment payments plus a final payment, as set forth in the Contract Documents. For each applicable installment payment, Contractor shall submit an Application for Payment in accordance with the Contract Documents. An Application for Payment will be processed by PWC as provided in the Contract Documents. Such installment payments shall reflect the actual cost of the Work, not to exceed in total the Price, and the allocable portion of the total Price for said installment. PWC shall make payment to the Contractor, less any applicable retainage set forth in the Contract Documents; provided, however, that PWC may withhold all or a portion of a payment on account of (1) incomplete Work, (2) defective or nonconforming Work, (3) claims filed or a reasonable basis to believe that such claims will be filed imminently, (4) failure of the Contractor to make payments properly for labor, services, materials, equipment or subcontracts, (5) damages caused to PWC or another party by one or more Responsible Persons, or (6) failure to comply with the terms and conditions of this Agreement. In the final payment, PWC shall pay the balance of the Price, including all retained amounts, less any Liquidated Damages and other applicable damage and claim amounts, to Contractor; provided, however, that PWC may withhold a reasonable sum from the final payment to ensure correction of any final items or condition on the Project.

6. Retainage. Subject to any restrictions applicable to any federal grant funds that may be utilized for the Project, PWC may, in its discretion, retain up to five percent (5%) of any periodic payment due Contractor; provided, however, when the Project is fifty percent (50%) complete, PWC, with written consent of the surety, shall not retain any further retainage from periodic payments due Contractor if Contractor continues to perform satisfactorily and any nonconforming Work identified in writing prior to that time by PWC or the Designer has been corrected by Contractor and accepted by PWC or the Designer, and provided further that full payment, less authorized deductions, shall also be made for those line item trades that have reached one hundred percent (100%) completion of their contract obligations by or before the Project is fifty percent (50%) complete if Contractor has performed satisfactorily in accordance with G.S. 143-134.1(b2), contingent upon PWC's receipt of an approval or certification from the Designer that the Work performed by the subcontractor is acceptable and in accordance with the Contract Documents. If PWC determines Contractor's performance is unsatisfactory, PWC may, in its discretion, reinstate retainage for each subsequent periodic Application for Payment as authorized in this Section up to the maximum amount of five percent (5%). The Project shall be deemed fifty percent (50%) complete when Contractor's gross project invoices, excluding the value of materials stored off-site, equal or exceed fifty percent (50%) of the Price, except the value of materials stored on-site shall not exceed twenty percent (20%) of Contractor's gross project invoices for the purpose of determining whether the Project is fifty percent (50%) complete. Within 60 days after the submission of a pay request and one of the following occurs, as specified in the Contract Documents, PWC, with written consent of the surety, shall release to Contractor all retainage on payments held by PWC: (i) PWC receives a certificate of substantial completion from the Designer in charge of the Project; or (ii) PWC receives beneficial occupancy or use of the Project; provided, however, PWC may in its discretion retain sufficient funds to secure Completion of the Project or corrections on any Work. If PWC retains funds, the amount retained shall not exceed two and one-half times the estimated value of the Work to be completed or corrected. Any reduction in the amount of the retainage on payments shall be with the consent of Contractor's surety. The existence of any third-party claims against

Contractor or any additive change orders to the Construction Documents shall not be a basis for delaying the release of any retainage on payments. Notwithstanding anything in this Section to the contrary, following fifty percent (50%) completion of the Project, PWC shall be authorized to withhold additional retainage from a subsequent periodic payment, not to exceed five percent (5%), in order to allow PWC to retain two and one-half percent (2.5%) total retainage through the Completion of the Project. In the event that PWC elects to withhold additional retainage on any periodic payment subsequent to release of retainage on a line-item of Work pursuant to G.S. 143-134.1(b2), Contractor may also withhold from the subcontractors remaining on the project sufficient retainage to offset the additional retainage held by PWC, notwithstanding the actual percentage of retainage withheld by PWC of the Project as a whole. Neither PWC's nor Contractor's release of retainage on payments as part of a payment in full on a line-item of work pursuant to G.S. 143-134.1(b2) shall affect any applicable warranties on Work done by Contractor or subcontractor, and the warranties shall not begin to run any earlier than either PWC's receipt of a certificate of substantial completion from the Designer in charge of the Project or PWC receives beneficial occupancy.

7. Liquidated Damages. Time is of the essence with respect to performance of each of the Parties' obligations under this Agreement. Contractor recognizes and acknowledges that PWC will suffer financial and other losses if the Project is not completed by the Completion Date. The Parties recognize and agree that the delays, expense, and difficulties involved in proving in a legal or arbitration proceeding the actual loss suffered by PWC if the Project is not completed by the Completion Date. Accordingly, instead of requiring any such proof, Contractor and PWC agree that in the event Contractor fails to achieve Completion of the Project by the Completion Date, Contractor shall pay to PWC as liquidated damages to compensate PWC for damages related to the delayed Completion of the Project the daily amount specified in the Contract Documents ("Liquidated Damages") for each calendar day Contractor fails to achieve completion of the Work by the Completion Date.

8. Contractor's Representations and Warranties. In order to induce PWC to enter into this Agreement, Contractor makes the following representations and warranties to PWC:

a. Contractor is duly licensed in the State of North Carolina to complete all Work necessary for the Project, is duly organized, validly existing and in good standing and has all requisite powers, rights, and authority to execute, enter into, and perform this Agreement in accordance with the terms and conditions of this Agreement, and this Agreement constitutes a legal, valid, and binding obligation of Contractor enforceable against it in accordance with its terms.

b. Contractor has read the Contract Documents, and acknowledges and understands all data, materials, specifications, and requirements identified in the Contract Documents.

c. Contractor has visited the site for the Project, conducted a thorough, visual examination of the site and adjacent areas, and become familiar with and is satisfied as to the general, local, and site conditions that may affect cost, progress, and performance in completing the Project.

d. Contractor is familiar with and is satisfied as to all laws and regulations that may affect cost, progress, and performance to complete the Project.

e. Contractor has carefully studied all: (1) reports of explorations and tests of subsurface conditions at or adjacent to the site and all drawings of physical conditions relating to existing surface or subsurface structures at the site that have been identified in the Detail Specifications and any accompanying reports and drawings, and (2) reports and drawings relating to hazardous environmental conditions, if any, at or adjacent to the site that have been identified in the Contract Documents and any accompanying reports and drawings.

f. Contractor has considered the information known to Contractor itself; information commonly known to contractors doing business in the locality of the Site; information and observations obtained from visits to the Site; the Contract Documents; and the Site-related reports and drawings identified in the Contract Documents, if any, with respect to the effect of such information, observations, and documents on (1) the cost, progress, and performance of the Work; (2) the means, methods, techniques, sequences, and procedures of construction to be employed by Contractor; and (3) Contractor's safety precautions and programs.

g. Based on the information and observations referred to in subsection e. of this Section, Contractor agrees that no further examinations, investigations, explorations, tests, studies, or data are necessary for the performance of the Work at the Price commencing on the commencement date and in accordance with the other terms and conditions of the Contract.

h. Contractor is aware of the general nature of work to be performed by PWC and others at the Site that relates to the Work as indicated in the Contract Documents.

i. Contractor has given PWC's Designer written notice of all conflicts, errors, ambiguities, or discrepancies that Contractor has discovered in the Contract Documents, and the written resolution thereof by the Designer is acceptable to Contractor.

j. The Contract Documents are generally sufficient to indicate and convey understanding of all terms and conditions for performance and furnishing of the Work.

k. Contractor's entry into this Agreement constitutes an incontrovertible representation by Contractor that, without exception, all prices in the Agreement are premised upon performing and furnishing the Work required by the Contract Documents.

l. Contractor has no business or personal relationship with any PWC Commissioner, officer, director, manager, or supervisor and Contractor covenants to disclose immediately to PWC any such relationship that develops during the performance of Work on the Project.

9. Contractor's Payment Obligations. Contractor shall pay all of its obligations arising out of or in connection with the Project in a timely manner to all persons supplying materials in the prosecution of the Work and to all laborers and others employed thereon.

10. Contractor's Damage Repair Obligations. Contractor shall be responsible for all damages to the property of the City and of PWC that may result from the normal procedure of a Responsible Person's actions in the prosecution of the Work or that may be caused by or result from the negligence of a Responsible Person during the progress of or connected with the prosecution of the Work, whether within the limits of the Work or elsewhere. Contractor shall promptly restore all such property so damaged to a condition as good as it was immediately prior to Contractor initiating the Work on the Project.

11. Defective Work. The Project shall be subject to observation and approval by PWC, Designer, and representatives of governmental agencies with jurisdiction over the Project. PWC and Designer shall be entitled to enter at all reasonable times the premises subject to construction or renovation to inspect the Work performed by or on behalf of Contractor, provided that such entry and inspection does not materially interfere with the progress of construction. Contractor shall correct promptly, at no cost to PWC, all Work reasonably rejected by PWC or by its representatives. Should Contractor fail to correct rejected Work, PWC may, acting in its sole discretion, correct such Work and the Contractor shall pay PWC's actual costs of correction and any other applicable amounts identified in the PWC General Conditions.

12. As-Built Drawings. Contractor shall maintain during the progress of the Project as-built drawings indicating the current status of the Project as actually performed. Upon Completion of the Project, Contractor shall prepare a final version of such as-built drawings and submit them to PWC for approval.

13. Assignment. This Agreement shall be binding upon and inure to the benefit of the Parties, their legal representatives, successors, and assigns. Contractor may not assign, transfer, convey, or encumber, whether voluntarily or by operation of law, this Agreement or any obligations, rights under, or interests in this Agreement to a third party without the prior written consent of PWC; and, specifically, but without limitation, money that may become due and money that is due may not be assigned without such consent (except to the extent that the effect of this restriction may be limited by law), and unless specifically stated to the contrary in any written consent to an assignment, no assignment will release or discharge the assignor from any duty or responsibility under the Contract Documents.

14. Indemnity. Contractor shall indemnify, defend, and hold harmless PWC and its Commissioners, officers, employees, agents, and representatives and the City and its elected officials, managers, employees, agents, and representatives and Designer (collectively "Indemnitees") from and against all claims, actions, liabilities, damages, losses, costs, and expenses (including, without limitation, injury to or death of any persons and damage to property, economic and consequential damages and attorneys' fees) asserted by one or more third parties against one or more of the Indemnitees if the Fault of one or more Responsible Persons is a proximate cause of the loss, damage, or expense indemnified. Contractor's obligation to indemnify, defend, and hold harmless the Indemnitees shall survive the termination of this Agreement.

15. Insurance. Contractor shall maintain during the completion of the Project and for at least three (3) years thereafter the insurance coverage set forth in the Contract Documents, which insurance shall be placed with insurance companies authorized to do business in the State of North Carolina and rated A minus VII or better by the current edition of Best's Key Rating Guide or otherwise approved in writing by PWC. Prior to initiating any Work on the Project, Contractor shall deliver certificates of insurance confirming each such coverage

required by the Contract Documents, and Contractor shall direct its insurers to provide annually to PWC certificates confirming each such coverage during the coverage period. PWC shall be named as an additional insured in the comprehensive automobile and commercial liability insurance policies. Commercial general liability coverage shall be written on an "occurrence" basis. Contractor shall not reduce or allow the required insurance coverages to lapse without PWC's prior written approval. All policies for insurance must be endorsed to contain a provision giving PWC a thirty (30) calendar day prior written notice by certified mail of any cancellation of that policy or material reduction in coverage. Should a notice of cancellation be issued for non-payment of premiums or any part thereof, or should Contractor fail to provide and maintain certificates as set forth herein, PWC shall have the right, but shall not have the obligation, to pay such premium to the insurance company or to obtain such coverage and to deduct such payment from any sums that may be due or become due to Contractor, or to seek reimbursement for said payments from Contractor. Any such sums paid by PWC shall be due and payable immediately by Contractor upon notice from PWC. The insurance provisions of this Agreement shall not be construed as a limitation on Contractor's responsibilities and liabilities pursuant to the terms and conditions of this Agreement. Contractor's obligation to maintain insurance for three (3) years after Completion of the Project shall survive the termination of this Agreement.

16. Warranty. Contractor's warranties to PWC pursuant to the PWC General Conditions shall be in addition to, and not in derogation of, all other rights and privileges which PWC may have under law, equity, or instrument, and shall survive the Completion Date and the final settlement and shall be binding on Contractor notwithstanding any provision in any other writing executed by PWC heretofore or contemporaneous with the execution of the Agreement or prior to the Completion Date.

17. Waiver. No failure on the part of any party to exercise, and no delay in exercising, any right, power, or privilege hereunder shall operate as a waiver thereof, nor shall any single or partial exercise of any right hereunder preclude any other or further cumulative and not exclusive of any remedies provided by law. This Agreement shall be binding upon and inure to the benefit of the parties, their legal representatives, successors, and assigns. This Agreement may not be assigned, transferred, conveyed, or encumbered, whether voluntarily or by operation of law, by either party without the prior written consent of the other party, which consent shall not be unreasonably withheld.

18. Law. THIS AGREEMENT SHALL BE GOVERNED BY AND INTERPRETED AND ENFORCED IN ACCORDANCE WITH THE LAWS OF THE STATE OF NORTH CAROLINA WITHOUT GIVING EFFECT TO THE CHOICE OF LAW PROVISIONS THEREOF. The Contractor shall at all times comply with all applicable Federal, state, and local laws and building codes in the performance of its obligations under the Agreement.

19. Dispute Resolution. In the event of any dispute, controversy, or claim of any kind or nature arising under or in connection with this Agreement (a "Dispute") and involving any two or more of the following parties, PWC, Designer, Contractor or any subcontractor of Contractor, the party initiating the Dispute shall serve written notice of a Dispute on the party(ies) to the dispute, and those parties shall endeavor to settle the dispute first through direct, informal discussions between the parties' selected representatives. Any such representative(s) shall have binding authority to settle the Dispute. In the event the parties do not settle the Dispute within ten (10) days from the date of written notice of the Dispute, any party to the Dispute may, by written notice to the other party(ies), engage a mediator certified under the laws of the State of North Carolina to mediate the Dispute within thirty (30) days of such notice. The parties to

the Dispute shall attend mediation in good faith. In the event mediation is unsuccessful, any party to the dispute may initiate arbitration proceedings. Any controversy or claim arising out of or relating to the Contract Documents, or the breach thereof, shall be settled by binding arbitration administered by the American Arbitration Association under its Construction Industry Arbitration Rules, and judgment on the award rendered by the arbitrator(s) may be entered in any court having jurisdiction thereof. All of the foregoing dispute resolution procedures shall be held in Cumberland County, North Carolina. The costs of the mediator and arbitrator in a dispute resolution process shall be divided equally among the parties to the process; provided, however, PWC shall bear at least one-third of the cost if PWC is a party to the dispute resolution and the remainder of the cost shall be divided equally among the other parties participating in the dispute resolution. PWC shall, in its contractual arrangements with Designer, and Contractor shall, in its contracts with subcontractors and they in their contracts with lower-tier subcontractors authorize and direct such parties to participate in the dispute resolution procedures set forth in this Section. Unless otherwise directed in writing by PWC, Contractor shall continue the Project and maintain compliance with the scheduling deadlines set forth in the Contract Documents during any dispute resolution proceedings. If Contractor continues to perform, PWC shall make payments due for the continued performance in accordance with this Agreement. The provisions of this Section shall not extend any applicable statutes of limitation or repose.

20. Execution; Modification; Entire Agreement; Severability. This Agreement may be executed in counterparts with the same effect as if the signatures to each counterpart were upon a single instrument, and all such counterparts together shall be deemed an original of this Agreement. For purposes of this Agreement, a facsimile copy or scanned copy or photocopy of a party's signature shall be sufficient to bind such party. This Agreement shall be subject to execution by electronic means in accordance with Article 40 of Chapter 66 of the North Carolina General Statutes. No oral communication, promise, understanding, or agreement before, contemporaneous with, or after the execution of this Agreement shall affect or modify any of the terms and conditions and obligations of the Contract Documents. The Contract Documents shall be modified only by a subsequent writing signed by both Parties. The Contract Documents shall be conclusively considered to contain and express all the terms and conditions agreed upon by the Parties, notwithstanding any prior or contemporaneous written communication, promise, understanding or agreement. Should any provision of this Agreement or any of the Contract Documents at any time be in conflict with any law, statute, rule, regulation, order, or ruling and thus be unenforceable, or be unenforceable for any other reason, then the remaining provisions of this Agreement shall remain in full force and effect and the court or arbitrator shall give the offending provision the fullest meaning and effect permitted by law. The titles of the Sections throughout this Agreement are for convenience only and the words contained therein shall in no way be held to explain, modify, amplify or aid in the interpretation, construction, or meaning of the provisions of this instrument.

21. Notices. Any notice which either Party is required or desires to give the other hereunder shall be deemed sufficiently given if, in writing, it is delivered personally, or sent by certified U.S. mail, return-receipt requested, postage prepaid, to the addresses listed herein below, or such other address as either Party shall give to the other Party by written notice in accordance herewith. Any notice given herein by personal delivery shall be deemed delivered when received. Any properly addressed notice given herein by certified mail shall be deemed delivered on third Business Day after the same is deposited in an official United States Post Office, postage prepaid, or if sooner upon the date when the return receipt therefore is signed, or refusal to accept the mailing by the addressee is noted thereon by the postal authorities.

To PWC:
Fayetteville Public Works Commission
Attn: Mick Noland, Interim CEO/General Manager
PO Box 1089
Fayetteville, NC 28302

To Contractor:
[INSERT MAILING ADDRESS]

22. Termination. This Agreement may be terminated in accordance with the PWC General Conditions.

23. Compliance. Contractor hereby acknowledges that “E-Verify” is the federal E-Verify program operated by the US Department of Homeland Security and other federal agencies which is used to verify the work authorization of newly hired employees pursuant to federal law and in accordance with Article 2, Chapter 64 of the North Carolina General Statutes. Contractor further acknowledges that all employers, as defined by Article 2, Chapter 64 of the North Carolina General Statutes, must use E-Verify and after hiring an employee to work in the United States, shall verify the work authorization of the employee through E-Verify in accordance with N.C.G.S. §64-26(a). Contractor hereby pledges, attests, and warrants through execution of this Agreement that Contractor complies with the requirements of Article 2, Chapter 64 of the North Carolina General Statutes and further pledges, attests, and warrants that all subcontractors currently employed by or subsequently hired by Contractor shall comply with all E-Verify requirements. Failure to comply with the above requirements shall be considered a breach of this Agreement. Contractor hereby further acknowledges that the execution and delivery of this Agreement constitutes Contractor’s certification to PWC and to the North Carolina State Treasurer that, as of the date of the Effective Date of this Agreement, Contractor is not listed on (a) the Final Divestment List created and maintained by the North Carolina Department of State Treasurer pursuant to the Iran Divestment Act of 2015, Chapter 147, Article 6E of the General Statutes of North Carolina (the “Iran Divestment Act”); or (b) the list of companies that the North Carolina State Treasurer determines to be engaged in a boycott of Israel in accordance with Article 6G of Chapter 147 of the General Statutes of North Carolina. Contractor represents and warrants to Commission that Contractor, and all persons and entities owning (directly or indirectly) an ownership interest in it: (i) are not, and will not become, a person or entity with whom a party is restricted from doing business with under regulations of the Office of Foreign Asset Control (“OFAC”) of the Department of the Treasury (including, but not limited to, those named on OFAC’s Specially Designated and Blocked Persons list) or under any statute, executive order (including, but not limited to, the September 24, 2001, Executive Order 13224 Blocking Property and Prohibiting Transactions with Persons Who Commit, Threaten to Commit, or Support Terrorism), or other governmental action; and (ii) are not knowingly engaged in, and will not knowingly engage in, any dealings or transactions or be otherwise associated with such persons or entities described in clause (i) above. Contractor also shall at all times during the term of this Agreement comply with Executive Order 11246, including but not limited to the Equal Opportunity Clause requirements set forth in 41 C.F.R. § 60-1.4. Contractor shall abide by the requirements of 41 CFR 60–300.5(a) and 60–741.5(a) prohibiting discrimination against qualified individuals on the basis of protected veteran status or disability and requiring affirmative action by covered prime contractors and subcontractors to employ and advance in employment qualified protected veterans and individuals with disabilities.

IN WITNESS WHEREOF, the Parties have executed this Agreement by their duly authorized representatives.

The City of Fayetteville, by and through the Fayetteville Public Works Commission

[CONTRACTOR FULL LEGAL NAME]

By: _____
Mick Noland, Interim CEO/General Manager

By: _____
_____, _____
(Printed Name) (Title)

Date: _____

Date: _____

This instrument has been preaudited in the manner required by the Local Government Budget and Fiscal Control Act (N.C. Gen. Stat. § 159-1 et seq.).

By: _____
Rhonda Haskins, Chief Financial Officer

Approved as to form:

James P. West, Chief Legal Officer



GENERAL CONDITIONS FOR
AST SYSTEM CONVERSION TO UST SYSTEM
FOR THE FAYETTEVILLE PUBLIC WORKS COMMISSION

General Conditions

General Conditions	5
Article I. Definitions and Terminology	5
Section 1.01 Definitions.....	5
Section 1.02 Terminology.....	9
Article II. Preliminary Matters	10
Section 2.01 Delivery of Bonds and Evidence of Insurance.....	10
Section 2.02 Copies of Documents.....	10
Section 2.03 Before Starting any Work.....	10
Section 2.04 Preconstruction Conference; Designation of Authorized Representatives.....	10
Section 2.05 Initial Acceptance of Schedules.....	11
Section 2.06 Electronic Transmittals.....	11
Article III. Contract Documents: Intent, Requirements, Reuse	11
Section 3.01 Intent.....	11
Section 3.02 Reference Standards.....	12
Section 3.03 Reporting and Resolving Discrepancies.....	12
Section 3.04 Reuse of Documents.....	13
Article IV. Commencement and Progress of the Work	13
Section 4.01 Commencement of Work.....	13
Section 4.02 Reference Points.....	13
Section 4.03 Progress Schedule.....	14
Section 4.04 Delays in Contractor’s Progress.....	14
Article V. Availability of Lands; Subsurface and Physical Conditions; Hazardous Environmental Conditions	14
Section 5.01 Availability of Lands.....	15
Section 5.02 Use of Site and Other Areas.....	15
Section 5.03 Differing Subsurface or Physical Conditions or Underground Facilities.....	16
Section 5.04 Underground Utilities.....	17
Section 5.05 Hazardous Environmental Conditions at Site.....	19
Article VI. Bonds and Insurance	20
Section 6.01 Performance and Payment Bonds.....	20
Section 6.02 Insurance.....	20
Article VII. Contractor’s Responsibilities	22
Section 7.01 Supervision and Superintendence.....	22
Section 7.02 Labor; Working Hours.....	22
Section 7.03 Services, Materials, and Equipment.....	23
Section 7.04 “Or Equals”.....	23
Section 7.05 Concerning Subcontractors, Suppliers, and Others.....	24
Section 7.06 Patent Fees and Royalties.....	25

General Conditions

Section 7.07	Permits	25
Section 7.08	Taxes	26
Section 7.09	Laws and Regulations	26
Section 7.10	Record Documents	26
Section 7.11	Safety and Protection	26
Section 7.12	Emergencies.....	27
Section 7.13	Shop Drawings, Samples, and Other Submittals	27
Section 7.14	Contractor's General Warranty and Guarantee.....	29
Section 7.15	Indemnification	30
Section 7.16	Claims Procedure	31
Section 7.17	Delegation of Professional Design Services	31
Article VIII.	PWC's Responsibilities	32
Article IX.	Amending the Contract Documents; Changes in the Work.....	32
Section 9.01	Amending and Supplementing Contract Documents.....	32
Section 9.02	PWC-Authorized Changes in the Work.....	33
Section 9.03	Unauthorized Changes in the Work	33
Section 9.04	Change of Contract Price.....	33
Section 9.05	Change of Contract Times	34
Section 9.06	Change Proposals	34
Section 9.07	Execution of Change Orders.....	35
Section 9.08	Notification to Surety.....	35
Article X.	Tests, Inspections, and Approvals; Correction, Removal, or Acceptance of Defective Work.....	35
Section 10.01	Access to Work	35
Section 10.02	Tests, Inspections, and Approvals.....	35
Section 10.03	Defective Work.....	36
Section 10.04	Acceptance of Defective Work	37
Section 10.05	Uncovering Work.....	37
Section 10.06	PWC May Stop the Work	38
Section 10.07	PWC May Correct Defective Work	38
Article XI.	Claims.....	39
Section 11.01	Claims Process	39
Section 11.02	Submittal of Claim	39
Section 11.03	Review and Resolution.....	39
Section 11.04	Dispute Resolution.....	39
Article XII.	Payments to Contractor; Set-Offs; Completion; Correction Period.....	40
Section 12.01	Progress Payments.....	40
Section 12.02	Substantial Completion	43

General Conditions

Section 12.03	Partial Use or Occupancy	43
Section 12.04	Final Inspection	44
Section 12.05	Final Payment	44
Section 12.06	Waiver of Claims	45
Section 12.07	Correction Period	45
Article XIII.	Suspension of Work and Termination	46
Section 13.01	PWC May Suspend Work.....	46
Section 13.02	PWC May Terminate for Cause.....	46
Section 13.03	PWC May Terminate For Convenience	47
Section 13.04	Contractor May Stop Work or Terminate	47
Section 13.05	Morality	48
Article XIV.	Miscellaneous	48
Section 14.01	Additional General Terms and Conditions	48
Section 14.02	Giving Notice.....	48
Section 14.03	Computation of Times	48
Section 14.04	Cumulative Remedies	48
Section 14.05	Limitation of Damages.....	49
Section 14.06	No Waiver	49
Section 14.07	Survival of Obligations.....	49
Section 14.08	Controlling Law	49
Section 14.09	Headings.....	49

General Conditions

Article I. Definitions and Terminology

Section 1.01 Definitions

Capitalized terms used in the Bid Documents or Contract Documents, including the singular and plural forms, shall have the meaning indicated in the definitions below. In addition to terms specifically defined below, terms with initial capital letters in the Contract Documents include references to identified articles and paragraphs, and the titles of other documents or forms.

- (a) **Addenda**—Written or graphic instruments issued before the opening of Bids which clarify, correct, or change the Bid Documents or other Contract Documents.
- (b) **Agreement**—The written instrument, executed by PWC and Contractor, that sets forth the Contract Price and Contract Times, identifies the parties, designates the specific documents that encompass the Contract Documents, and provides other material provisions that govern the relationship between the parties as it relates to the Project. The Agreement is also referred to, and titled as, the “Construction Agreement.”
- (c) **Application for Payment**—The form that Contractor shall use during the Work in requesting progress or final payments. Any Application for Payment shall be accompanied by such supporting documentation as is required by the Contract Documents.
- (d) **Bid**—The offer of a Bidder submitted on the prescribed form setting forth the prices for the Work to be performed.
- (e) **Bidder**—An individual or entity that submits a Bid to PWC for the Project.
- (f) **Bid Documents**—The Bidding Requirements, the proposed Contract Documents, and all Addenda.
- (g) **Bidding Requirements**—The Invitation to Bid, Instructions to Bidders, Bid Bond or other Bid security, if any, the Bid Form, and the Bidder’s original Bid with any requisite attachments.
- (h) **Business Day**—each calendar day that is not a Saturday, Sunday, or holiday observed by PWC (New Year’s Day, Martin Luther King, Jr. Day, Good Friday, Memorial Day, Independence Day, Labor Day, Veteran’s Day, Thanksgiving Day (and the day after), and Christmas (2 days) for its employees.
- (i) **Change Order**—A document that is signed by Contractor and PWC, which authorizes an addition, deletion, or revision in the Work, an adjustment in the Contract Price or the Contract Times, a change in the scope of the Project, or other revision to the Agreement, issued on or after the Effective Date of the Agreement.
- (j) **Change Proposal**—A written request by Contractor, submitted in compliance with the procedural requirements set forth in the Contract Documents, seeking an adjustment in Contract Price or Contract Times, or both; contesting an initial decision by PWC concerning the requirements of the Contract Documents or the acceptability of Work under the Contract Documents; challenging a set-off against payments due; or seeking other relief with respect to the terms of the Agreement.

General Conditions

- (k) Completion of the Project—Has the meaning as set forth in the Construction Agreement.
- (l) Constituent of Concern—Asbestos, petroleum, radioactive materials, polychlorinated biphenyls (PCBs), hazardous waste, and any substance, product, waste, or other material of any nature whatsoever that is or becomes listed, regulated, or addressed pursuant to (a) the Comprehensive Environmental Response, Compensation and Liability Act, 42 U.S.C. §§9601 et seq. (“CERCLA”); (b) the Hazardous Materials Transportation Act, 49 U.S.C. §§5101 et seq.; (c) the Resource Conservation and Recovery Act, 42 U.S.C. §§6901 et seq. (“RCRA”); (d) the Toxic Substances Control Act, 15 U.S.C. §§2601 et seq.; (e) the Clean Water Act, 33 U.S.C. §§1251 et seq.; (f) the Clean Air Act, 42 U.S.C. §§7401 et seq.; or (g) any other federal, state, or local statute, law, rule, regulation, ordinance, resolution, code, order, or decree regulating, relating to, or imposing liability or standards of conduct concerning, any hazardous, toxic, or dangerous waste, substance, or material.
- (m) Contract Price—The money that PWC has agreed to pay Contractor for Completion of the Project in accordance with the Contract Documents. May also be referred to as “Price” throughout the Contract Documents.
- (n) Contract Times—The number of days or the dates by which Contractor shall: (a) achieve Milestones, if any; and (b) Completion of the Project.
- (o) Contractor—The individual or entity with which PWC has contracted for performance of the Work and Completion of the Project.
- (p) Day—a calendar day of 24 hours measured from midnight to the next midnight. Also referred to throughout the Contract Documents as “days” or “calendar days.”
- (q) Design Engineer—The Engineering firm identified on the Contract Drawings and their duly authorized employees and agents, such employees and agents acting within the scope of the particular duties entrusted to them in each case.
- (r) Drawings—The part of the Contract that graphically shows the scope, extent, and character of the Work to be performed by Contractor.
- (s) Field Order—A written order issued by Project Engineer which requires minor changes in the Work but does not change the Contract Price or the Contract Times.
- (t) Final Completion—The day the on which any specified Work is complete in accordance with the Contract Documents.
- (u) Laws and Regulations; Laws or Regulations—Any and all applicable laws, statutes, rules, regulations, ordinances, codes, and orders of any and all governmental bodies, agencies, authorities, and courts having jurisdiction. Such terms, unless otherwise specified, shall refer to North Carolina laws and regulations.
- (v) Milestone—A principal event in the performance of the Work that the Agreement requires Contractor to achieve by an intermediate completion date or by a time prior to Completion of the Project.
- (w) Non-Compliance Notice—A written notice issued by PWC to Contractor indicating a

General Conditions

violation of any term, provision, or requirement of the Contract Documents.

- (x) Notice of Award—The written notice by PWC to a Bidder providing of PWC's acceptance of the Bid upon timely compliance by the Bidder with any conditions precedent provided in the notice.
- (y) Notice to Proceed—A written notice by PWC to Contractor fixing the date on which the Contract Times will commence to run and on which Contractor shall start to perform the Work.
- (z) Progress Schedule—A schedule, prepared and maintained by Contractor, describing the sequence and duration of the activities comprising the Contractor's plan to accomplish the Work within the Contract Times.
- (aa) Project—has the meaning ascribed to it in the Agreement and is as more specifically set forth throughout the Contract Documents. "Project" includes the total undertaking to be accomplished for PWC by engineers, contractors, and others, including planning, study, design, construction, testing, commissioning, and start-up, and of which the Work to be performed under the Contract Documents is a part.
- (bb) Project Engineer—the PWC employee assigned by PWC to coordinate, manage, monitor, and otherwise perform the administration necessary and consistent with PWC's responsibilities for the Completion of the Project. The Project Engineer has authority to coordinate and work with the Design Engineer regarding any engineering questions, concerns, revisions, alterations, deletions, or additions to the Work, and has authority to approve any changes in the scope of the Work. Project Engineer may assign a "Project Coordinator" who will also be an employee of PWC and have the duties and responsibilities set by the Project Engineer.
- (cc) PWC—Fayetteville Public Works Commission. PWC may also be referred to in the Contract Documents as "Owner."
- (dd) Samples—Physical examples of materials, equipment, or workmanship that are representative of some portion of the Work and that establish the standards by which such portion of the Work will be judged.
- (ee) Schedule of Submittals—A schedule, prepared and maintained by Contractor, of required submittals and the time requirements for Project Engineer's review of the submittals and the performance of related construction activities.
- (ff) Schedule of Values—A schedule, prepared and maintained by Contractor, allocating portions of the Contract Price to various portions of the Work and used as the basis for reviewing Contractor's Applications for Payment.
- (gg) Shop Drawings—All drawings, diagrams, illustrations, schedules, and other data or information that are specifically prepared or assembled by or for Contractor and submitted by Contractor to illustrate some portion of the Work. Shop Drawings, whether approved or not, are not Contract Drawings and are not Contract Documents.
- (hh) Site—Lands or areas indicated in the Contract Documents as being furnished by PWC upon which the Work is to be performed, including rights-of-way and easements, and such other lands furnished by PWC which are designated for the use of Contractor.

General Conditions

- (ii) Specifications—The part of the Contract that consists of written requirements for materials, equipment, systems, standards, and workmanship as applied to the Work, and certain administrative requirements and procedural matters applicable to the Work.
- (jj) Subcontractor—An individual or entity having a direct contract with Contractor or with any other Subcontractor for the performance of a part of the Work.
- (kk) Substantial Completion—The time at which the Work (or a specified part thereof) has progressed to the point where, in the opinion of Project Engineer, the Work (or a specified part thereof) is sufficiently complete, in accordance with the Contract Documents, so that the Work (or a specified part thereof) can be utilized for the purposes for which it is intended. The terms “substantially complete” and “substantially completed” as applied to all or part of the Work refer to Substantial Completion thereof.
- (ll) Successful Bidder—The Bidder whose Bid PWC accepts, and to which PWC provides a Notice of Award.
- (mm) Supplementary Conditions—Any part of the Agreement that amends or supplements these General Conditions.
- (nn) Supplier—A manufacturer, fabricator, supplier, distributor, materialman, or vendor having a direct contract with Contractor or with any Subcontractor to furnish materials or equipment to be incorporated in the Work by Contractor or a Subcontractor.
- (oo) Technical Data—Those items expressly identified as Technical Data in the Supplementary Conditions, with respect to either (a) subsurface conditions at the Site, or physical conditions relating to existing surface or subsurface structures at the Site (except Underground Facilities) or (b) Hazardous Environmental Conditions at the Site. If no such express identifications of Technical Data have been made with respect to conditions at the Site, then the data contained in boring logs, recorded measurements of subsurface water levels, laboratory test results, and other factual, objective information regarding conditions at the Site that are set forth in any geotechnical or environmental report prepared for the Project and made available to Contractor are hereby defined as Technical Data with respect to conditions at the Site under Paragraphs 5.03, 5.04, and 5.06.
- (pp) Underground Facilities—All underground pipelines, conduits, ducts, cables, wires, manholes, vaults, tanks, tunnels, or other such facilities or attachments, and any encasements containing such facilities, including but not limited to those that convey electricity, gases, steam, liquid petroleum products, telephone or other communications, fiber optic transmissions, cable television, water, wastewater, storm water, other liquids or chemicals, or traffic or other control systems.
- (qq) Unit Price Work—Work to be paid for on the basis of unit prices.
- (rr) Work—The entire construction or the various separately identifiable parts thereof required to be provided under the Contract Documents. Work includes and is the result of performing or providing all labor, services, materials, equipment, and documentation necessary to produce such construction; furnishing, installing, and incorporating all materials and equipment into such construction; and may include related services such as testing, start-up, and commissioning, all as required by the Contract Documents and necessary to achieve Completion of the Project.

General Conditions

- (ss) Work Change Directive—A written directive to Contractor issued on or after the Effective Date of the Contract, signed by PWC and recommended by the Project Engineer, ordering an addition, deletion, or revision in the Work.

Section 1.02 Terminology

The words and terms discussed in the following paragraphs are not defined but, when used in the Bidding Requirements or Contract Documents, have the indicated meaning.

(a) Intent of Certain Terms or Adjectives:

- (i) The Contract Documents include the terms “as allowed,” “as approved,” “as ordered,” “as directed” or terms of like effect or import to authorize an exercise of professional judgment by Project Engineer. In addition, the adjectives “reasonable,” “suitable,” “acceptable,” “proper,” “satisfactory,” or adjectives of like effect or import are used to describe an action or determination of Project Engineer as to the Work. It is intended that such exercise of professional judgment, action, or determination will be solely to evaluate, in general, the Work for compliance with the information in the Contract Documents and with the design concept of the Project as a functioning whole as shown or indicated in the Contract Documents (unless there is a specific statement indicating otherwise). The use of any such term or adjective is not intended to and shall not be effective to assign to Project Engineer any duty or authority to supervise or direct the performance of the Work, or any duty or authority to undertake responsibility contrary to the provisions the Contract Documents.

(b) Defective—when modifying the word “Work,” refers to Work that is unsatisfactory, faulty, or deficient in that it:

- (i) does not conform to the Contract Documents; or
(ii) does not meet the requirements of any applicable inspection, reference standard, test, or approval referred to in the Contract Documents; or
(iii) has been damaged prior to Project Engineer’s recommendation of final payment (unless responsibility for the protection thereof has been assumed by PWC at Substantial Completion in accordance with the Contract Documents).

(c) Furnish, Install, Perform, Provide

- (i) The word “furnish,” when used in connection with services, materials, or equipment, shall mean to supply and deliver said services, materials, or equipment to the Site (or some other specified location) ready for use or installation and in usable or operable condition.
(ii) The word “install,” when used in connection with services, materials, or equipment, shall mean to put into use or place in final position said services, materials, or equipment complete and ready for intended use.
(iii) The words “perform” or “provide,” when used in connection with services, materials, or equipment, shall mean to furnish and install said services, materials, or equipment complete and ready for intended use.
(iv) If the Contract Documents establish an obligation of Contractor with respect to specific services, materials, or equipment, but do not expressly use any of the four words “furnish,” “install,” “perform,” or “provide,” then Contractor shall furnish and install said services, materials, or equipment complete and ready for intended use.

General Conditions

Unless stated otherwise in the Contract Documents, words or phrases that have a well-known technical or construction industry or trade meaning are used in the Contract Documents in accordance with such recognized meaning.

Article II. Preliminary Matters

Section 2.01 Delivery of Bonds and Evidence of Insurance

- (a) Bonds: Contractor shall deliver to PWC such bonds as Contractor is required to furnish simultaneously with delivering the executed Agreement to PWC.
- (b) Contractor's Insurance: Contractor shall deliver to PWC the certificates and other evidence of the insurance required by the Contract Documents simultaneously with delivering the executed Agreement to PWC.

Section 2.02 Copies of Documents

- (a) PWC will furnish to Contractor up to five (5) printed copies of the Contract Documents upon request by Contractor, and one (1) copy in electronic portable document format (PDF). Additional printed copies will be furnished upon request at the cost of reproduction.
- (b) PWC will maintain and safeguard at least one original printed record version of the Agreement, including Drawings and Specifications signed and sealed by Design Engineer or other design professionals as applicable. PWC agrees to make such original printed record version of the Agreement reasonably available to Contractor for review during PWC's normal business hours. PWC may delegate the responsibilities under this provision to Design Engineer.

Section 2.03 Before Starting any Work

- (a) Within ten (10) Days after the Contractor receives the Notice of Award from PWC (or as otherwise specifically required by the Contract Documents), Contractor shall submit to PWC for timely review:
 - (i) a preliminary Progress Schedule indicating the times (numbers of days or dates) for starting and completing the identifiable aspects of the Work, including any Milestones specified in the Contract Documents;
 - (ii) a preliminary Schedule of Submittals; and
 - (iii) Any Shop Drawings, Samples, and other submittals required by the Contract Documents before the Preconstruction Conference.

Section 2.04 Preconstruction Conference; Designation of Authorized Representatives

- (a) Before any Work at the Site is started, a preconstruction conference attended by PWC, Project Engineer, Contractor, Design Engineer, and others as appropriate will be held to establish a working understanding among the parties as to the Work and to discuss general Project issues including, but not limited, the following:
 - (i) The schedules and submittals referred to in Section 2.03;
 - (ii) Contractor's designated authorized representative as described in Section 2.04(b);
 - (iii) Safety;
 - (iv) Procedures for handling Shop Drawings, Samples, and other submittals;

General Conditions

- (v) Processing Applications for Payment, electronic or digital transmittals;
- (b) At the preconstruction conference Contractor shall designate, in writing, a specific individual to act as its authorized representative with respect to its services and responsibilities under the Contract Documents. Such individual shall have the authority to transmit and receive information, render decisions relative to the requirements of the Contract Documents, and otherwise act on behalf of the Contractor.

Section 2.05 Initial Acceptance of Schedules

- (a) At least twenty (20) Days before submission of the first Application for Payment a conference, attended by Contractor, PWC, and others as appropriate, will be held to review for acceptability to Project Engineer as provided below the schedules submitted in accordance with Paragraph 2.03(a). PWC shall have ten (10) Days to review the submission and provide feedback to Contractor. Contractor shall then have ten (10) days to make any corrections and adjustments as indicated by PWC and to complete and resubmit the schedules as necessary. No progress payment shall be made to Contractor until acceptable schedules are submitted to and approved by Project Engineer.
- (b) The Progress Schedule will be acceptable to Project Engineer if it provides an orderly progression of the Work to achieve Completion of the Project within the Contract Times. Such acceptance will not impose on Project Engineer responsibility for the Progress Schedule, for sequencing, scheduling, or progress of the Work, nor interfere with or relieve Contractor from Contractor's full responsibility therefor.
- (c) Contractor's Schedule of Submittals will be acceptable to Project Engineer if it provides a workable arrangement for reviewing and processing the required submittals.

Section 2.06 Electronic Transmittals

- (a) Except as otherwise stated elsewhere in the Contract Documents, PWC and Contractor and their authorized agents may transmit, and shall accept, Project-related correspondence, text, data, documents, drawings, information, and graphics, including but not limited to Shop Drawings and other submittals, in electronic media or digital format, either directly, or through electronic mail at the address(es) designated by each Party.
- (b) When transmitting items in electronic media or digital format, the transmitting party makes no representations as to long term compatibility, usability, or readability of the items resulting from the recipient's use of software application packages, operating systems, or computer hardware differing from those used in the drafting or transmittal of the items, or from those established in applicable transmittal protocols.

Article III. Contract Documents: Intent, Requirements, Reuse

Section 3.01 Intent

- (a) The Contract Documents are complementary; what is required by one is as binding as if required by all.
- (b) It is the intent of the Contract Documents to describe a functionally complete project (or part thereof) to be constructed in accordance with the Contract Documents.

General Conditions

- (c) Project Engineer, Design Engineer, or both, will issue clarifications and interpretations of the Contract Documents as provided herein.
- (d) To the extent necessary that Work, construction, or conditions not covered by these General Conditions is required for Contractor to achieve Completion of the Project, "Special Conditions" for such Work will be provided to Contractor and shall be part of the Contract Documents.
- (e) In case of any inconsistency, conflict, or ambiguity among the Contract Documents, the documents shall govern in the following order: (1) Change Orders; (2) Addenda; (3) the fully executed Agreement; (4) Special Conditions; (5) any Drawings and Technical Specifications; and (6) General Conditions.

Section 3.02 Reference Standards

- (a) Standards Specifications, Codes, Laws and Regulations
 - (i) Reference in the Contract Documents to standard specifications, manuals, reference standards, or codes of any technical society, organization, or association, or to Laws or Regulations, whether such reference be specific or by implication, shall mean the standard specification, manual, reference standard, code, or North Carolina laws and regulations in effect as of the Effective Date of the Agreement, except as may be otherwise specifically stated in the Contract Documents.
 - (ii) No provision of any such standard specification, manual, reference standard, or code, or any instruction of a Supplier shall be effective to change the duties or responsibilities of PWC or Contractor, or any of their subcontractors, consultants, agents, or employees, from those set forth in the Contract Documents. No such provision or instruction shall be effective to assign to PWC or any of its officers, directors, members, partners, employees, agents, consultants, or subcontractors, any duty or authority to supervise or direct the performance of the Work or any duty or authority to undertake responsibility inconsistent with the provisions of the part of the Contract Documents.

Section 3.03 Reporting and Resolving Discrepancies

- (a) Contractor's Verification of Figures and Measurements
 - (i) Before undertaking any portion of the Work, Contractor shall review all of the Contract Documents to and check and verify all figures and dimensions for the Project. Contractor shall promptly report in writing to Project Engineer any conflict, error, ambiguity, or discrepancy that Contractor discovers, or has actual knowledge of, and shall not proceed with any Work affected thereby until the conflict, error, ambiguity, or discrepancy is resolved, by a clarification or interpretation by Project Engineer, or by an amendment or supplement to the Contract Documents issued pursuant to these General Conditions.
 - (ii) If, before or during the performance of the Work, Contractor discovers any conflict, error, ambiguity, or discrepancy within the Contract Documents, or between the Contract Documents and (a) any applicable Law or Regulation, (b) actual field conditions, (c) any standard specification, manual, reference standard, or code, or (d) any instruction of any Supplier, then Contractor shall promptly report it to Project Engineer in writing. Contractor shall not proceed with the Work affected thereby (except in an emergency as defined hereinafter) until the conflict, error, ambiguity, or discrepancy is resolved, by a clarification

General Conditions

or interpretation by Project Engineer, or by an amendment or supplement to the Contract Documents issued pursuant to these General Conditions.

(b) Resolving Discrepancies:

- (i) Except as may be otherwise specifically stated in the Contract Documents, the provisions of the part of the Contract Documents prepared by or for PWC shall take precedence in resolving any conflict, error, ambiguity, or discrepancy between such provisions of the Contract Documents and:
 - 1) the provisions of any standard specification, manual, reference standard, or code, or the instruction of any Supplier (whether or not specifically incorporated by reference as a Contract Document); or
 - 2) the provisions of any Laws or Regulations applicable to the performance of the Work (unless such an interpretation of the provisions of the Contract Documents would result in violation of such Law or Regulation).

Section 3.04 Reuse of Documents

- (a) Contractor and its Subcontractors and Suppliers shall not have or acquire any title to or ownership rights in any of the:
 - (i) Drawings, Specifications, or other documents (or copies of any thereof) prepared by or bearing the seal of Design Engineer or its consultants, including electronic media editions, or reuse any such Drawings, Specifications, other documents, or copies thereof on extensions of the Project or any other project without written consent of PWC and Design Engineer and specific written verification or adaptation by Design Engineer, where applicable; or
 - (ii) Contract Documents and shall not reuse any such Contract Documents for any purpose without PWC's express written consent.
- (b) The prohibitions of this provision shall survive final payment or termination of the Agreement. Nothing herein shall preclude Contractor from retaining copies of the Contract Documents for record purposes.

Article IV. Commencement and Progress of the Work

Section 4.01 Commencement of Work

- (a) The Contract Times will commence to run on the day indicated in the Notice to Proceed issued by PWC to Contractor. A Notice to Proceed may be given at any time after the Effective Date of the Contract.
- (b) Contractor shall start to perform the Work on the date when the Contract Times commence to run. No Work shall be done at the Site prior to such date. Contractor's failure to commence the Work within fifteen (15) Days of the date stated in the Notice to Proceed shall be deemed a material breach of the Agreement unless PWC otherwise determines in its sole discretion and agrees in writing to a delay of the Contract Times based on the applicable circumstances.

Section 4.02 Reference Points

General Conditions

- (a) Construction staking will be performed by Design Engineer, who will also prepare and furnish construction cut sheets, signed and sealed by a North Carolina professional land surveyor, to PWC and Contractor. Contractor shall not install any utilities without a sheet. All requests for staking shall be made not less than 96 hours in advance.
- (b) Contractor shall be responsible for laying out the Work, shall protect and preserve the established reference points and staking, and shall make no changes or relocations without the prior written approval of Project Engineer. Contractor shall report to Project Engineer whenever any reference point staking is lost or destroyed or requires relocation because of necessary changes in grades or locations, and shall be responsible for the accurate replacement or relocation of such reference points or staking by professionally qualified personnel.

Section 4.03 Progress Schedule

- (a) Contractor shall adhere to the Progress Schedule established in accordance with Section 2.03 as it may be adjusted from time-to-time as provided below. Contractor shall submit to Project Engineer for acceptance any proposed adjustments in the Progress Schedule that will not result in changing the Contract Times. Proposed adjustments in the Progress Schedule that will change the Contract Times shall be submitted in accordance with the requirements of Article IX.
- (b) Contractor shall carry on the Work and adhere to the Progress Schedule during any disputes or disagreements with PWC. No Work shall be delayed or postponed pending resolution of any disputes or disagreements, or during any appeal process, except as permitted by these General Conditions or as PWC and Contractor may otherwise agree in writing.

Section 4.04 Delays in Contractor's Progress

- (a) If PWC, Project Engineer, anyone for whom PWC is responsible, or a Force Majeure Event delays, disrupts, or interferes with the performance or progress of the Work, then Contractor shall be entitled to an equitable adjustment in the Contract Times and Contract Price. Contractor's entitlement to an adjustment of the Contract Times is conditioned on such adjustment being essential to Contractor's ability to complete the Work within the Contract Times.
- (b) Contractor shall not be entitled to an adjustment in Contract Price or Contract Times for delay, disruption, or interference caused by or within the control of Contractor. Delay, disruption, and interference attributable to and within the control of a Subcontractor or Supplier shall be deemed to be within the control of Contractor.
- (c) Contractor must submit any Change Proposal, consistent with the procedure set forth in Article IX, seeking an adjustment in Contract Price or Contract Times under this provision within ten (10) calendar days of the commencement of the event that causes the delay, disruption, or interference with the Work and Contract Times.

Article V. Availability of Lands; Subsurface and Physical Conditions; Hazardous Environmental Conditions

General Conditions

Section 5.01 Availability of Lands

- (a) PWC will be responsible for obtaining any required easements and encroachments, and otherwise furnishing the Site, necessary to complete the Work, except as provided elsewhere in the Contract Documents.
- (b) Upon reasonable written request, PWC shall furnish to Contractor a current statement of record legal title and legal description of the lands upon which the Work is to be completed and PWC's interest therein.
- (c) Contractor shall provide for all additional lands and access thereto that may be required for temporary construction facilities or storage of materials and equipment necessary to complete the Work. Any and all agreements between the Contractor and any individual property owner(s) shall not obligate PWC, PWC's employees, Project Engineer, or Design Engineer in any manner, and Contractor shall, before performing any work on any such property, obtain a signed and notarized release of liability of PWC and Design Engineer that is suitable to PWC as confirmed in writing.
- (d) Contractor and any of its Subcontractors shall exercise care and caution to avoid damage to any private property. Should any such damage to private property occur, it is Contractor's responsibility to notify the Project Engineer promptly in writing that such damage occurred, the extent of the damage, and Contractor's written plan to remedy the damage. If Contractor fails to timely correct damage to private property, PWC reserves the right to withhold progress payments until damage is corrected and/or to correct damage and back-charge Contractor for costs incurred. At the Completion of the Project, Contractor shall obtain a signed release from all owners of private property to which damage occurred that releases PWC and Design Engineer and acknowledges a settlement for the damage or that such damage was adequately remedied.

Section 5.02 Use of Site and Other Areas

- (a) Contractor shall confine construction equipment, temporary construction facilities, the storage of materials and equipment, and the operations of workers to the Site and other adjacent areas permitted by Laws and Regulations and shall not unreasonably encumber the Site and such other adjacent areas with construction equipment or other materials or equipment. Contractor shall assume full responsibility for (a) damage to the Site; (b) damage to any such other adjacent areas used for Contractor's operations; (c) damage to any other adjacent land or areas; and (d) for injuries and losses sustained by the owners or occupants of any such land or areas; provided that such damage or injuries result from the performance of the Work or from other actions or conduct of the Contractor or those for which Contractor is responsible.
- (b) Contractor shall keep the Site and other adjacent areas free from accumulations of waste materials, rubbish, and other debris during the progress of the Work. Removal and disposal of such debris shall conform to applicable Laws and Regulations.
- (c) Prior to Completion of the Project, Contractor shall clean the Site and the Work and make it ready for utilization by PWC. At the completion of all of the Work, Contractor shall remove from the Site and adjacent areas all tools, appliances, construction equipment and machinery, and surplus materials and shall restore to original condition all property not designated for alteration by the Contract Documents.

General Conditions

- (d) Contractor shall not load nor permit any part of any structure to be loaded in any manner that will endanger the structure, nor shall Contractor subject any part of the Work or adjacent structures or land to stresses or pressures that will endanger them.

Section 5.03 Differing Subsurface or Physical Conditions or Underground Facilities

- (a) If Contractor believes that any subsurface or physical condition or Underground Facilities that is uncovered or revealed at the Site either:
 - (i) is of such a nature as to establish that any Technical Data on which Contractor is entitled to rely is materially inaccurate;
 - (ii) is of such a nature as to require a change in the Contract Documents;
 - (iii) differs materially from that shown or indicated in the Contract Documents; or
 - (iv) is of an unusual nature, and differs materially from conditions ordinarily encountered and generally recognized as inherent in work of the character provided for in the Contract Documents;

then Contractor shall, promptly after becoming aware thereof and before further disturbing the subsurface or physical conditions or Underground Facilities or performing any Work in connection therewith, notify PWC and Engineer in writing about such condition. Contractor shall not further disturb such condition or perform any Work in connection therewith (except with respect to an emergency) until receipt of a written statement approved by PWC permitting Contractor to do so.

- (b) After receipt of Contractor's written notice, Project Engineer will review the subsurface or physical condition or Underground Facilities in question; determine the necessity of PWC obtaining additional exploration or tests with respect to the condition; conclude whether the condition falls within any of the differing site condition categories in this Section 5.03; and obtain any pertinent cost or schedule information from Contractor.
- (c) Project Engineer will issue a written statement to Contractor regarding the subsurface or physical condition or Underground Facilities in question, which addresses the resumption of Work in connection with such condition and indicates whether any change in the Contract Documents will be made.
- (d) Possible Price and Times Adjustments:
 - (i) Contractor shall be entitled to an equitable adjustment in Contract Price or Contract Times, or both, to the extent that the existence of a differing subsurface or physical condition or Underground Facilities, or any related delay, disruption, or interference, causes an increase or decrease in Contractor's cost of, or time required for, performance of the Work; subject, however, to the following:
 - 1) such condition must fall within at least one of the categories in this Section 5.03; and,
 - 2) Contractor's entitlement to an adjustment of the Contract Times is conditioned on such adjustment being essential to Contractor's ability to complete the Work within the Contract Times.
 - (ii) Contractor shall not be entitled to any adjustment in the Contract Price or Contract Times with respect to a subsurface or physical condition or Underground Facilities if:
 - 1) Contractor knew of the existence of such condition at the time Contractor proffered its

General Conditions

- 2) Bid to PWC or executed the applicable Agreement for the Project; or
 - 2) the existence of such condition reasonably could have been discovered or revealed as a result of any examination, investigation, exploration, test, or study of the Site and contiguous areas expressly required by the Bidding Requirements or Contract Documents to be conducted by or for Contractor prior to Contractor's Bid; or
 - 3) Contractor failed to give the written notice as required.
- (iii) If PWC and Contractor agree regarding Contractor's entitlement to, and the amount or extent of, any adjustment in the Contract Price or Contract Times, or both, then any such adjustment shall be set forth in a Change Order.
- (iv) Contractor may submit a Change Proposal regarding its entitlement to or the amount or extent of any adjustment in the Contract Price or Contract Times, or both, no later than 30 calendar days after Project Engineer's written statement to Contractor regarding the subsurface or physical condition or Underground Facilities in question.

Section 5.04 Underground Utilities

- (a) Contractor shall ascertain the location and type of all underground utility lines or structures that may be located within the limits of the Site or any area where Work is to be performed.
- (i) The exact location of underground utilities or structures may vary from prior plans, permits, maps, or other documentation, and others may not be designated. The Contractor is fully responsible for verification of the exact location of all underground utility lines or structures within the limits of the Site or the area where the work is to be performed, whether known or unknown by PWC, and for providing necessary protection and/or repair if damage.
 - (ii) Should uncharted or incorrectly charted piping or other utilities be encountered during excavations, the Contractor shall immediately halt any Work, notify PWC, and await direction from PWC before proceeding with any Work. The Contractor shall fully cooperate with PWC and any other utility company in keeping respective services and facilities in operation.
- (b) PWC has used reasonable care to locate and depict existing underground installation on the construction drawings, but the accuracy cannot be guaranteed, and some items may not be shown which exist. Actual horizontal and vertical locations have not been verified. As part of the Work, the Contractor is required to dig up each utility which may conflict with construction in advance to verify locations. The utilities shall be "dug up" a minimum of fourteen (14) Days in advance of actual installation of new utilities to allow PWC an opportunity to adjust grades and alignments, to avoid a conflict, and to address any other issues.
- (c) The Contractor shall adhere to the provisions of the North Carolina Underground Utility Safety and Damage Prevention Act. The Contractor shall make a documented request to the North Carolina One Call Center, and/or individual utility owners, in order to locate any facilities within the Site limits or any area where Work is to be performed at least forty-eight (48) hours in advance of the day the Work is scheduled to begin. The Contractor shall include the cost of any coordination and cooperation for utilities in its Bid.

General Conditions

- (i) Location assistance requested from PWC by Contractor should include the actual horizontal location, type number, size, and depth of all lines. All costs associated with locating and marking existing utilities or the utilities representatives shall be the responsibility of the Contractor.
- (ii) The Owner, Project Engineer, Design Engineer, and/or Consultants shall not be liable to the Contractor for any claims, costs, losses, or damages incurred or sustained on or in connection with locating existing underground installations.
- (d) If the Contractor fails to schedule locates or perform advance physical locations in advance of the construction and a conflict arises, the Contractor will be required to make corrective measures as instructed by the Project Engineer at the Contractor's expense. The Contractor's failure to advance plan (minimum fourteen (14) days) by physically uncovering existing utilities in advance of construction shall not be cause for claim of lost time or for additional compensation. No additional payment will be made for re-mobilization required by the utility locator.
 - (i) The Contractor shall inform all equipment operators, either those employed by him or those employed by his subcontractors, of information obtained from the utility owners prior to initiation of any aspect of any Work.
- (e) PWC and Design Engineer shall not be responsible for the accuracy or completeness of any information or data provided to the Contractor with respect to underground facilities.
- (f) The entire cost of all of the following will be included in the Contract Price, and Contractor shall bear full responsibilities for all such costs, including but not limited to:
 - (i) Reviewing and checking all such information and data;
 - (ii) Locating all underground facilities shown or indicated in the Contract Documents;
 - (iii) Coordination of the Work with the owners of such underground facilities, including PWC, during any portion of the Work; and
 - (iv) The safety and protection of all such underground facilities and repairing any damage thereto resulting from the Work.
- (g) Contractor shall be responsible for the discovery of existing underground installations, in advance of any excavating or trenching as required in the Contract Documents.
- (h) If an underground facility is discovered at or contiguous to the Site that was not shown or indicated in the Contract Documents or of which Contractor was not aware prior to starting that portion of any Work, Contractor shall, immediately after becoming aware thereof and before further disturbing conditions affected thereby or performing any Work in connection therewith (except in an emergency), identify the owner of such underground facility and give written notice to PWC. Upon receipt of written notice, PWC will review the pertinent condition, determine the necessity of obtaining additional information, and advise Contractor in writing. During such time, Contractor shall be responsible for the safety and

General Conditions

protection of such underground facility. If PWC concludes that a change in the Contract Documents is required, a Change Order will be issued.

- (i) The Contract Price and/or the Contract Time, may be adjusted if PWC determines, in its discretion, that the existence of such differing subsurface or physical condition causes an increase or decrease in Contractor's cost of, or time required for, performance of the Work subject to the following:
 - 1) Facility was not shown or indicated in the Contract Documents, and
 - 2) The Contractor did not know of or could not anticipate the facility.

Section 5.05 Hazardous Environmental Conditions at Site

- (a) Contractor shall not be responsible for removing or remediating any Hazardous Environmental Condition encountered, uncovered, or revealed at the Site unless such removal or remediation is expressly identified in the Contract Documents to be within the scope of the Work or Hazardous Environmental Condition was caused by Contractor.
- (b) Contractor shall be responsible for controlling, containing, and removing all Constituents of Concern brought to the Site by Contractor, Subcontractors, Suppliers, or anyone else for whom Contractor is responsible, and for any associated costs; and for the costs of removing and remediating any Hazardous Environmental Condition created by the presence of any such Constituents of Concern.
- (c) If Contractor encounters, uncovers, or reveals a Hazardous Environmental Condition whose removal or remediation is not expressly identified in the Contract Documents as being within the scope of the Work, or if Contractor or anyone for whom Contractor is responsible creates a Hazardous Environmental Condition, then Contractor shall immediately: (1) secure or otherwise isolate such condition; (2) stop all Work in connection with such condition and in any area affected thereby (except in an emergency); and (3) immediately notify Project Engineer (and promptly thereafter confirm such notice in writing). Project Engineer will evaluate such condition or take corrective action, if any. If Contractor or anyone for whom Contractor is responsible created the Hazardous Environmental Condition in question, then PWC may have the Hazardous Environmental Condition removed and remediated and impose a set-off against payments to Contractor to account for the reasonable associated costs.
- (d) Contractor shall not resume Work in connection with such Hazardous Environmental Condition or in any affected area until after PWC has delivered written notice to Contractor either (1) specifying that such condition and any affected area is or has been rendered safe for the resumption of Work, or (2) specifying any special conditions under which such Work may be resumed safely.
- (e) If PWC and Contractor cannot agree as to entitlement to or on the amount or extent, if any, of any adjustment in Contract Price or Contract Times, or both, as a result of such Work stoppage or such special conditions under which Work is agreed to be resumed by Contractor, then within thirty (30) calendar days of PWC's written notice regarding the resumption of Work, Contractor may submit a Change Proposal or PWC may impose a set-off.
- (f) If after receipt of such written notice Contractor does not agree to resume such Work

General Conditions

based on reasonable evidence it is unsafe or does not agree to resume such Work under such special conditions, then PWC may order the portion of the Work that is in the area affected by such condition to be deleted from the Work.

Article VI. Bonds and Insurance

Section 6.01 Performance and Payment Bonds

- (a) Contractor shall obtain and furnish to PWC a performance bond in the amount of one hundred percent (100%) of the Contract Price, conditioned upon the faithful performance of the Project and all Work in accordance with the Contract Documents, which bond shall be solely for the protection of PWC.
- (b) Contractor shall obtain and furnish to PWC a payment bond in the amount of one hundred percent (100%) of the Contract Price, conditioned upon the prompt payment for all labor or materials for which the Contractor or one or more of its subcontractors is liable, which payment bond shall be solely for the protection of the persons furnishing materials or performing labor for which the Contractor is liable.
- (c) The performance bond and the payment bond shall be executed by one or more surety companies legally authorized to do business in the State of North Carolina, shall become effective upon the awarding of the construction contract by PWC to Contractor, and shall at all times comply with the requirements set forth in Article 3 of North Carolina General Statutes Chapter 44A.
- (d) In the event PWC deems the surety or sureties upon any bond necessary for the Agreement and the completion of the Project, or if for any reason, such bond ceases to be adequate to cover the performance and/or payment of the Work, Contractor shall, at its expense, and within ten (10) days after the receipt of notice from PWC, furnish such additional bond(s) in such form and amount, and with such surety or sureties, as shall be satisfactory to PWC. In such event no further payment to Contractor shall be deemed to be due under this Agreement until new or additional security for the performance and payment of the Project shall be furnished in manner and form satisfactory to PWC.
- (e) By executing the Agreement, Contractor understands and acknowledges that PWC, as a public authority, and the City, as a municipal corporation, are not subject to the provisions of Articles 1 and 2 of Chapter 44A of the General Statutes, in accordance with G.S. 44A-34 and applicable law.

Section 6.02 Insurance

- (a) Contractor shall maintain during the life of the Agreement and during the completion of any Work the following insurance coverages, which insurance shall be placed with insurance companies authorized to do business in the State of North Carolina and rate A minus VII or better by the current edition of Best's Key Rating Guide or otherwise approved in writing by PWC:
 - (i) Commercial general liability insurance with limits of \$1,000,000 per occurrence, \$2,000,000 aggregate other than products/completed operations; \$2,000,000 aggregate for products/completed. Commercial general liability coverage shall be written on an "occurrence" basis.

General Conditions

- (ii) Automobile liability insurance in an amount not less than \$1,000,000 combined single limit per accident for bodily injury and property damage from owned, non-owned, and hired automobiles.
- (iii) Workers' compensation insurance as required by the Laws and Regulations. In the event any employee(s), contractor(s), or subcontractor(s) engaged to perform any Work under the Agreement is not protected under the applicable workers' compensation laws, the Contractor shall provide adequate coverage for the protection of such employee(s), contractor(s), or subcontractor(s) not otherwise protected.
- (iv) In the event the Project concerns building construction or repair work, Contractor shall purchase and maintain "Builder's Risk" insurance. This insurance shall include the interests of the PWC, Contractor, and any Subcontractor(s) and shall be written on a one hundred percent (100%) completed value basis (full value as of the date that all construction is finished and includes the Contractor's Contract Price), and to remain in force until Completion of the Project.
- (v) Regardless of the nature of the work to be performed, coverage must also be provided for the theft or damage of building materials and supplies, which are not permanently attached or stored on Site for any period of time. This coverage shall be an "Installation Floater." If no building construction or repair is involved for the Project, the amount of the coverage shall equal the value of the materials stored on site.
- (b) Prior to initiating any Work on the Project, Contractor shall deliver certificates of insurance confirming each such coverage set forth above, and Contractor shall direct its insurers to provide annually to PWC certificates confirming each such coverage during the coverage period.
- (c) PWC shall be named as an additional insured in the comprehensive automobile and commercial liability insurance policies.
- (d) Contractor shall not reduce or allow the required insurance coverages to lapse without PWC's prior written approval. All policies for insurance must be endorsed to contain a provision giving PWC a thirty (30) calendar day prior written notice by certified mail of any cancellation of that policy or material reduction in coverage. Should a notice of cancellation be issued for non-payment of premiums or any part thereof, or should Contractor fail to provide and maintain certificates as set forth herein, PWC shall have the right, but shall not have the obligation, to pay such premium to the insurance company or to obtain such coverage and to deduct such payment from any sums that may be due or become due to Contractor, or to seek reimbursement for said payments from Contractor. Any such sums paid by PWC shall be due and payable immediately by Contractor upon notice from PWC.
- (e) The insurance coverage requirements shall not be construed as a limitation on Contractor's responsibilities and liabilities pursuant to the terms and conditions of this Agreement. Contractor's obligation to maintain insurance for three (3) years after Completion of the Project shall survive the termination of this Agreement.
- (f) If Contractor fails to obtain and maintain any required insurance, PWC may exclude Contractor from the Site, impose an appropriate set-off against payment, and exercise PWC's termination rights pursuant to the Contract Documents.

General Conditions

- (g) PWC does not represent that insurance coverage and limits established in this Contract necessarily will be adequate to protect Contractor or Contractor's interests.

Article VII. Contractor's Responsibilities

Section 7.01 Supervision and Superintendence

- (a) Contractor shall supervise, inspect, and direct the Work competently and efficiently, devoting such attention and applying such skills and expertise as may be necessary to perform the Work in accordance with the Contract Documents. Contractor shall be solely responsible for the means, methods, techniques, sequences, and procedures of construction subject to the terms, provisions, and specifications set forth in the Contract Documents.
- (b) At all times during the progress of the Work, Contractor shall assign a competent superintendent, satisfactory to Project Engineer, to supervise the Work and to respond to Project Engineer concerning PWC's interests in the Work.
- (c) Contractor's superintendent shall have full authority to act on behalf of Contractor and all communications, instructions, directions, and notices given to the superintendent by the Project Engineer shall be binding to the Contractor.
- (d) Contractor's superintendent shall be responsible for coordination of the Work with other contractors or subcontractors. The superintendent shall not be replaced without written notice to PWC except under extraordinary circumstances.
- (e) Subcontractors
 - (i) Contractor shall submit the names and references all Subcontractors to the Project Engineer for approval before commencing any Work.
 - 1) In the event Contractor seeks to substitute any Subcontractor that was identified in Contractor's Bid, Contractor shall promptly provide PWC with: (1) the Subcontractor it seeks to substitute; (2) the identity of the Subcontractor to be substituted; and (3) the reason for the requested substitution.
 - 2) PWC will review the requested substitution within five (5) Business Days and provide written approval or denial of the substitution, with such approval not to be unreasonably withheld.
 - (ii) Contractor's superintendent shall be available to be present at the Site at any time that any Subcontractor(s) is performing any of the Work. Construction activity shall be stopped if the Contractor's superintendent is not available to be at the Site.

Section 7.02 Labor; Working Hours

- (a) Contractor shall provide competent, suitably qualified personnel to survey and lay out the Work and perform construction as required by the Contract Documents. Contractor shall at all times maintain good discipline and order at the Site. Contractor shall remove from the

General Conditions

Project any person who appears incompetent, disorderly, or otherwise unsatisfactory. Contractor shall also remove any person who appears in PWC's sole discretion to be incompetent, disorderly, or otherwise unsatisfactory

- (b) Except as otherwise required for the safety or protection of persons or the Work or property at the Site or adjacent thereto, and except as otherwise stated in the Contract Documents, all Work at the Site shall be performed on Business Days. Contractor will not perform Work on non-Business Days. Contractor may perform Work outside regular working hours or on Saturdays, Sundays, or legal holidays only with PWC's written consent, which will not be unreasonably withheld. In such circumstances, Contractor shall submit a written request to PWC at least two (2) Business Days prior to any Work that it requests to complete on a non-Business Day and PWC will, in its sole discretion, approve or deny such request. If such work outside of a Business Day is approved, PWC will set forth the specific parameters that Contractor must follow, including time of work, personnel, and any other issues.⁸

Section 7.03 Services, Materials, and Equipment

- (a) Unless otherwise specified in the Contract Documents, Contractor shall provide and assume full responsibility for all services, materials, equipment, labor, transportation, construction equipment and machinery, tools, appliances, fuel, power, light, heat, telephone, water, sanitary facilities, temporary facilities, and all other facilities and incidentals necessary for the performance, testing, start up, and Completion of the Project, whether or not such items are specifically called for in the Contract Documents.
- (b) All materials and equipment incorporated into the Work shall be of good quality and new, except as otherwise specified in the Contract Documents. All special warranties and guarantees required by the Specifications shall expressly run to the benefit of PWC. If required by PWC or its designee, Contractor shall furnish satisfactory evidence (including reports of required tests) as to the source, kind, and quality of materials and equipment.
- (c) All materials and equipment shall be stored, applied, installed, connected, erected, protected, used, cleaned, and conditioned in accordance with instructions of the applicable Supplier, except as otherwise may be specified in the Contract Documents.

Section 7.04 "Or Equals"

- (a) Whenever an item of material or equipment is specified or described in the Contract Documents by using the name of a proprietary item or the name of a particular Supplier, the specification or description of such an item is intended to establish the type, function, appearance, and quality required. Unless the specification or description contains or is followed by words reading that no like, equivalent, or "or equal" item is permitted, Contractor may request that Project Engineer authorize the use of other items of material or equipment under the circumstances described below.
 - (i) If Project Engineer determines that an item of material or equipment proposed by Contractor is functionally equal to that named and sufficiently similar so that no change in related Work will be required, Project Engineer shall deem it an "or equal" item and confirm such in writing to Contractor. A proposed item of material or equipment will be considered functionally equal to an item so named if:
 - 1) in the exercise of reasonable judgment Project Engineer determines that:

General Conditions

- a) it is at least equal in materials of construction, quality, durability, appearance, strength, and design characteristics;
 - b) it will reliably perform at least equally well the function and achieve the results imposed by the design concept of the completed Project as a functioning whole;
 - c) it has a proven record of performance and availability of responsive service; and
 - d) it is not objectionable to PWC.
- 2) Contractor certifies that, if approved and incorporated into the Work:
- a) there will be no increase in the Contract Price or Contract Times; and
 - b) it will conform substantially to the detailed requirements of the item specified in the Contract Documents.
- (b) Contractor shall provide all data in support of any proposed "or equal" item at Contractor's expense.
- (c) Project Engineer will be allowed a reasonable time to evaluate each "or-equal" request. Project Engineer may require Contractor to furnish additional data about the proposed "or-equal" item. Project Engineer will be the sole judge of acceptability. Contractor shall not order, furnish, install, or utilize any "or-equal" it until Project Engineer has reviewed the request, determined that the proposed item is an "or-equal," and provided written confirmation to Contractor.
- (d) Project Engineer's denial of an "or-equal" request shall be final and binding and may not be reversed through an appeal under any provision of the Contract Documents.

Section 7.05 Concerning Subcontractors, Suppliers, and Others

- (a) Contractor may retain Subcontractors and Suppliers for the performance of parts of the Work. Such Subcontractors and Suppliers must be acceptable to PWC.
- (b) Contractor shall not subcontract more than forty-nine percent (49%) of the final Contract Price.
- (c) Contractor shall retain specific Subcontractors, Suppliers, or other individuals or entities for the performance of designated parts of the Work if required by the Contract Documents.
- (d) After the submittal of Contractor's Bid or final negotiation of the terms of the Agreement, PWC may not require Contractor to retain any Subcontractor, Supplier, or other individual or entity to furnish or perform any of the Work.
- (e) Prior to entry into any binding subcontract or purchase order, Contractor shall submit to PWC the identity of the proposed Subcontractor or Supplier (unless PWC has already deemed such proposed Subcontractor or Supplier acceptable, during the bidding process or otherwise). Such proposed Subcontractor or Supplier shall be deemed acceptable to PWC unless PWC raises a substantive, reasonable objection within five (5) Business Days.
- (f) No acceptance by PWC of any such Subcontractor, Supplier, or other individual or entity, whether initially or as a replacement, shall constitute a waiver of the right of PWC to the completion of the Work in accordance with the Contract Documents.

General Conditions

- (g) Contractor shall be fully responsible to PWC for all acts and omissions of the Subcontractors, Suppliers, and other individuals or entities performing or furnishing any of the Work just as Contractor is responsible for Contractor's own acts and omissions.
- (h) Contractor shall be solely responsible for scheduling and coordinating the Subcontractors, Suppliers, and all other individuals or entities performing or furnishing any of the Work.
- (i) Contractor shall restrict all Subcontractors, Suppliers, and such other individuals or entities performing or furnishing any of the Work from communicating with PWC, except through Contractor or in case of an emergency, or as otherwise expressly allowed herein.
- (j) All Work performed for Contractor by a Subcontractor or Supplier shall be pursuant to an appropriate contractual agreement that specifically binds the Subcontractor or Supplier to the applicable terms and conditions of the Contract Documents for the benefit of PWC.
- (k) PWC may furnish to any Subcontractor or Supplier, to the extent practicable, information about amounts paid to Contractor on account of Work performed for Contractor by the particular Subcontractor or Supplier.
- (l) Nothing in the Contract Documents:
 - (i) shall create for the benefit of any such Subcontractor, Supplier, or other individual or entity any contractual relationship between PWC or Design Engineer and any such Subcontractor, Supplier, or other individual or entity; nor
 - (ii) shall create any obligation on the part of PWC or Design Engineer to pay or to see to the payment of any money due any such Subcontractor, Supplier, or other individual or entity except as may otherwise be required by Laws and Regulations.

Section 7.06 Patent Fees and Royalties

- (a) Contractor shall pay all license fees and royalties and assume all costs incident to the use in the performance of the Work or the incorporation in the Work of any invention, design, process, product, or device that is the subject of patent rights or copyrights held by others. If a particular invention, design, process, product, or device is specified in the Contract Documents for use in the performance of the Work and if, to the actual knowledge of PWC, its use is subject to patent rights or copyrights calling for the payment of any license fee or royalty to others, the existence of such rights shall be disclosed by PWC in the Contract Documents.

Section 7.07 Permits

- (a) Unless otherwise specified in the Contract Documents, Contractor shall obtain and pay for all construction permits and licenses necessary to achieve Completion of the Project. Contractor shall timely seek assistance from PWC if necessary to obtain any permits or licenses; provided that, the Contract Time shall not be extended if PWC determines, in its discretion, that Contractor delayed or otherwise did not act expeditiously in requesting such assistance. PWC shall assist Contractor, when necessary, in obtaining such permits and licenses. Contractor shall pay all governmental charges and inspection fees necessary for Completion of the Project that are applicable at the time of the submission of Contractor's Bid.

General Conditions

Section 7.08 Taxes

- (a) Contractor shall pay all sales, consumer, use, and other similar taxes required to be paid by Contractor in accordance with the applicable Laws and Regulations for the Project and which are applicable during the performance of the Work.

Section 7.09 Laws and Regulations

- (a) Contractor shall give all notices required by, and shall comply with, all Laws and Regulations applicable to the Project. Except as otherwise expressly required, PWC shall not be responsible for monitoring Contractor's compliance with any Laws or Regulations.
- (b) Contractor shall bear all resulting costs and losses for any of its actions or inactions that are contrary to Laws or Regulations.
- (c) PWC or Contractor may give notice to the other party of any changes after the submission of Contractor's Bid (or after the date when Contractor became bound under the Agreement) concerning any Laws or Regulations having an effect on the Contract Price or Contract Times, including but not limited to changes in Laws or Regulations having an effect on procuring permits and on sales, use, value-added, consumption, and other similar taxes. If PWC and Contractor are unable to agree on entitlement to or on the amount or extent, if any, of any adjustment in Contract Price or Contract Times resulting from such changes, then within 30 calendar days of such notice Contractor may submit a Change Proposal.

Section 7.10 Record Documents

- (a) Contractor shall maintain in good order one (1) printed record copy of all Drawings, Specifications, Addenda, Change Orders, Work Change Directives, Field Orders, written interpretations and clarifications, and approved Shop Drawings. These record documents, together with all approved Samples, will be available to Project Engineer for reference. Upon completion of the Work, Contractor shall deliver these record documents to PWC.

Section 7.11 Safety and Protection

- (a) Contractor shall be solely responsible for initiating, maintaining, and supervising all safety precautions and programs in connection with the Work. Such responsibility does not relieve Subcontractors of their responsibility for the safety of persons or property in the performance of their work, nor for compliance with applicable safety Laws and Regulations. Contractor shall take all necessary precautions for the safety of, and shall provide the necessary protection to prevent damage, injury, or loss to:
 - (i) all persons on the Site or who may be affected by the Work;
 - (ii) all the Work and materials and equipment to be incorporated therein, whether in storage on or off the Site; and
 - (iii) other property at the Site or adjacent thereto, including trees, shrubs, lawns, walks, pavements, roadways, structures, other work in progress, utilities, and Underground Facilities not designated for removal, relocation, or replacement in the course of construction.
- (b) Contractor shall comply with all applicable Laws and Regulations relating to the safety of persons or property, or to the protection of persons or property from damage, injury, or

General Conditions

loss, and shall erect and maintain all necessary safeguards for such safety and protection. Contractor shall notify PWC, the owners of adjacent property or Underground Facilities, and other contractors and owners performing work at or adjacent to the Site, when prosecution of the Work may affect them, and shall cooperate with them in the protection, removal, relocation, and replacement of their property or work in progress.

- (c) Contractor shall comply with the requirement of any of PWC's applicable health programs, which may be revised from time to time based on specific circumstances or applicable guidance from the Center for Disease Control or other applicable entity. Such health programs will be identified in the Special Conditions if applicable to the Project.
- (d) Contractor shall comply with the requirements of PWC's applicable safety programs. The Special Conditions identify any of PWC's safety programs that are applicable to the Project.
- (e) Contractor shall remedy, at its expense, all damage, injury, or loss to any property caused, directly or indirectly, in whole or in part, by Contractor, any Subcontractor, Supplier, or any other individual or entity directly or indirectly employed by any of them to perform any of the Work, or anyone for whose acts any of them may be liable.
- (f) Contractor's duties and responsibilities for safety and protection shall continue until such time as Completion of the Project is achieved.
- (g) Contractor's duties and responsibilities for safety and protection shall resume whenever Contractor or any Subcontractor or Supplier returns to the Site to fulfill warranty or correction obligations, or to conduct other tasks arising from the Contract Documents.
- (h) Contractor shall designate in writing to PWC a qualified and experienced safety representative at the Site whose duties and responsibilities shall be the prevention of accidents and the maintaining and supervising of safety precautions and programs.

Section 7.12 Emergencies

- (a) In emergencies affecting the safety or protection of persons or the Work or property at the Site or adjacent thereto, Contractor is obligated to, and shall, act to prevent threatened damage, injury, or loss. Contractor shall give PWC prompt written notice if Contractor believes that any significant changes in the Work or variations from the Contract Documents have been caused or are required as a result of any emergency. If PWC determines that a change in the Contract Documents is required because of the action taken by Contractor in response to such an emergency, a Work Change Directive or Change Order will be issued.

Section 7.13 Shop Drawings, Samples, and Other Submittals

- (a) Contractor shall timely submit Shop Drawings and Samples required by the Contract Documents to Project Engineer for review and approval in accordance with applicable specifications.
- (b) Before submitting a Shop Drawing or Sample, Contractor shall have
 - (i) reviewed the Shop Drawing or Sample with other Shop Drawings and Samples and with the requirements of the Work and the Contract Documents;

General Conditions

- (ii) verified all measurements, quantities, dimensions, performance and design criteria, installation requirements, materials, catalog numbers, and similar information;
 - (iii) verified the suitability of all materials and equipment offered with respect to the indicated application, fabrication, shipping, handling, storage, assembly, and installation pertaining to the performance of the Work; and
 - (iv) verified all information relative to Contractor's responsibilities for means, methods, techniques, sequences, and procedures of construction, and safety precautions and programs incident thereto.
- (c) With each submittal, Contractor shall give Project Engineer specific written notice of any variations that the Shop Drawing or Sample may have from the requirements of the Contract Documents. This notice shall be a written communication separate from the Shop Drawings or Sample submittal; and, in addition, in the case of Shop Drawings by a specific notation made on each Shop Drawing submitted to PWC for review and approval of each such variation.
- (d) Where a Shop Drawing or Sample is required by the Contract Documents, any related Work performed prior to Project Engineer's review and approval of the pertinent submittal will be at the sole expense and responsibility of Contractor.
- (e) Project Engineer will provide timely review of any required Shop Drawings and Samples. Such review, and subsequent determination of approval, will be only to determine if the items covered by the submittals will, after installation or incorporation in the Work, conform to the information given in the Contract Documents and be compatible with the design concept of the completed Project as a functioning whole as indicated by the Contract Documents.
- (f) Project Engineer's review and approval will not extend to means, methods, techniques, sequences, or procedures of construction or to safety precautions or programs incident thereto.
- (g) Project Engineer's review and approval of a Shop Drawing or Sample, or of a variation from the requirements of the Contract Documents, shall not change the Contract Times or Contract Price, unless such changes are included in a Change Order.
- (h) Project Engineer's receipt, review, acceptance or approval of a Shop Drawing, Sample, or other submittal shall not result in such item becoming a Contract Document.
- (i) Contractor shall perform the Work in compliance with the requirements and commitments set forth in approved Shop Drawings and Samples.
- (j) Resubmittal Procedures:
- (i) Contractor shall make corrections required by Project Engineer and shall return the required number of corrected copies of Shop Drawings and submit new Samples as required for review and approval. Contractor shall direct specific attention in writing to revisions other than the corrections called for by PWC or Project Engineer on previous submittals.
 - (ii) Contractor shall furnish required submittals with sufficient information and accuracy to obtain required approval of an item with no more than three (3) submittals. If PWC has

General Conditions

engaged a Design Engineer for the Project, Design Engineer will record Design Engineer's time for reviewing a fourth or subsequent submittal of a Shop Drawings, sample, or other item requiring approval, and Contractor shall be responsible for Design Engineer's charges to PWC for such time. PWC may impose a set-off against payments due to Contractor to secure reimbursement for such charges.

- (iii) If Contractor requests a change of a previously approved submittal item, Contractor shall be responsible for Design Engineer's charges to PWC for its review time, and PWC may impose a set-off against payments due to Contractor to secure reimbursement for such charges, unless the need for such change is beyond the control of Contractor.

Section 7.14 Contractor's General Warranty and Guarantee

- (a) In order to induce PWC to enter into an Agreement with Contractor for the Project, Contractor warrants and guarantees to PWC that:
 - (i) Contractor is duly licensed in the State of North Carolina to complete all Work necessary for the Project, is duly organized, validly existing and in good standing and has all requisite powers, rights, and authority to execute, enter into, and perform the Agreement in accordance with the terms and conditions of the Agreement, and the Agreement constitutes a legal, valid, and binding obligation of Contractor enforceable against it in accordance with its terms.
 - (ii) Contractor has read the Contract Documents, and acknowledges and understands all data, materials, specifications, and requirements identified in the Contract Documents.
 - (iii) Contractor has visited the site for the Project, conducted a thorough, visual examination of the site and adjacent areas, and become familiar with and is satisfied as to the general, local, and site conditions that may affect cost, progress, and performance in completing the Project.
 - (iv) Contractor is familiar with and is satisfied as to all laws and regulations that may affect cost, progress, and performance to complete the Project.
 - (v) Contractor has carefully studied all: (1) reports of explorations and tests of subsurface conditions at or adjacent to the site and all drawings of physical conditions relating to existing surface or subsurface structures at the site that have been identified in the Detail Specifications and any accompanying reports and drawings, and (2) reports and drawings relating to hazardous environmental conditions, if any, at or adjacent to the site that have been identified in the Contract Documents and any accompanying reports and drawings.
 - (vi) Contractor has considered the information known to Contractor itself; information commonly known to contractors doing business in the locality of the Site; information and observations obtained from visits to the Site; the Contract Documents; and the Site-related reports and drawings identified in the Contract Documents, if any, with respect to the effect of such information, observations, and documents on (1) the cost, progress, and performance of the Work; (2) the means, methods, techniques, sequences, and procedures of construction to be employed by Contractor; and (3) Contractor's safety precautions and programs.
 - (vii) Based on the information and observations referred to in subsection "(v)" of this Section, Contractor agrees that no further examinations, investigations, explorations, tests, studies, or data are necessary for the performance of the Work at the Contract Price and in accordance with the other terms and conditions of the Contract Documents.
 - (viii) Contractor is aware of the general nature of work to be performed by PWC and others at the Site that relates to the Work as indicated in the Contract Documents.
 - (ix) Contractor has given PWC written notice of all conflicts, errors, ambiguities, or

General Conditions

- discrepancies that Contractor has discovered in the Contract Documents, and the written resolution thereof by PWC is acceptable to Contractor.
- (x) The Contract Documents are generally sufficient to indicate and convey understanding of all terms and conditions for performance and furnishing of the Work.
 - (xi) Contractor's entry into this Agreement constitutes an incontrovertible representation by Contractor that, without exception, all prices in the Agreement are premised upon performing and furnishing the Work required by the Contract Documents.
 - (xii) Contractor has no business or personal relationship with any PWC Commissioner, officer, director, manager, or supervisor and Contractor covenants to disclose immediately to PWC any such relationship that develops during the performance of Work on the Project.
- (b) Contractor's obligation to perform and complete the Work in accordance with the Contract Documents shall be absolute. None of the following will constitute an acceptance of Work that is not in accordance with the Contract Documents or a release of Contractor's obligation to perform the Work in accordance with the Contract Documents:
- (i) observations by Project Engineer;
 - (ii) recommendation by Project Engineer or payment by PWC of any progress or final payment;
 - (iii) the issuance of a certificate of Substantial Completion by Project Engineer or any payment related thereto by PWC;
 - (iv) use or occupancy of the Work or any part thereof by PWC;
 - (v) any review and approval of a Shop Drawing or Sample submittal;
 - (vi) the issuance of a notice of acceptability by Project Engineer;
 - (vii) any inspection, test, or approval by others; or
 - (viii) any correction of defective Work by PWC.
- (c) If the Contract Documents requires the Contractor to accept the assignment of a contract entered into by PWC, then the specific warranties, guarantees, and correction obligations contained in the assigned contract shall govern with respect to Contractor's performance obligations to PWC for the Work described in the assigned contract.

Section 7.15 Indemnification

- (a) Contractor shall indemnify, defend, and hold harmless PWC and its Commissioners, officers, employees, agents, and representatives and the City and its elected officials, managers, employees, agents, and representatives and Designer (collectively "Indemnitees") from and against all claims, actions, liabilities, damages, losses, costs, and expenses (including, without limitation, injury to or death of any persons and damage to property, economic and consequential damages and attorneys' fees) asserted by one or more third parties against one or more of the Indemnitees if the Fault of one or more Responsible Persons is a proximate cause of the loss, damage, or expense indemnified.
- (b) Contractor's obligation to indemnify, defend, and hold harmless the Indemnitees shall survive the termination of the Agreement.
- (c) In any and all claims against the Indemnitees of Contractor, any Subcontractor, any Supplier, or any individual or entity directly or indirectly employed by any of them to perform any of the Work, or anyone for whose acts any of them may be liable, Contractor's indemnification obligation shall not be limited in any way by any limitation on the amount or type of damages, compensation, or benefits payable by or for Contractor or any such Subcontractor, Supplier, or other individual or entity under workers' compensation acts,

General Conditions

disability benefit acts, or other employee benefit acts.

Section 7.16 Claims Procedure

- (a) PWC shall notify the Contractor of all potential claims related to the Work within seven (7) calendar days of receiving notification or having knowledge of such potential claim. Should the Contractor receive a potential claim related to the Work, the Contractor shall notify PWC within seven (7) calendar days of receiving notification. The Contractor shall provide the claimant and PWC with a written response acknowledging receipt of the claim within seven (7) calendar days.
- (b) If the Contractor meets with the Claimant about the claim, a representative designated by PWC shall be present at all times. PWC shall maintain a record of any claim received, and the steps taken to resolve. PWC shall also concurrently investigate each case. The Contractor agrees to furnish PWC any information regarding the claim, the actions which led to the claim and/or the investigation of the claim. Contractor shall provide their proposed response to PWC within thirty (30) calendar days of receiving the claim. Upon receipt of the response PWC and the Contractor will discuss and reach a mutual agreement of the response necessary to send to the Claimant within fifteen (15) calendar days. Once the agreement is made the Contractor shall make a formal written resolution to the claimant.
- (c) Failure to act in good faith or respond to a claim in the timelines established by the Contract Documents will constitute a lack of response by the Contractor, therefore validating the claim. PWC will deduct the total amount of the claim from the monthly pay application. Failure to comply with the above requirements for resolving claims may, at the sole discretion of PWC, result in breach of contract.
- (d) The Contractor is aware of these claims procedures and understands that it is the PWC's practice to pursue reimbursement/subrogation for any and all claims related expenses, which are incurred as a result of the Contractor's performance under this Contract Documents and allowed within the applicable statute of limitations.

Section 7.17 Delegation of Professional Design Services

- (a) Contractor will not be required to provide professional design services unless such services are specifically required by the Contract Documents for a portion of the Work or unless such services are required to carry out Contractor's responsibilities for construction means, methods, techniques, sequences and procedures. Contractor shall not be required to provide professional services in violation of applicable Laws and Regulations.
- (b) If professional design services or certifications by a design professional related to systems, materials, or equipment are specifically required of Contractor by the Contract Documents, PWC will specify all performance and design criteria that such services must satisfy. Contractor shall cause such services or certifications to be provided by a properly licensed professional, whose signature and seal shall appear on all drawings, calculations, specifications, certifications, and other submittals prepared by such professional. Shop Drawings and other submittals related to the Work designed or certified by such professional, if prepared by others, shall bear such professional's written approval when submitted to PWC.

General Conditions

- (c) PWC shall be entitled to rely upon the adequacy, accuracy, and completeness of the services, certifications, or approvals performed by such design professionals, provided PWC has specified to Contractor all performance and design criteria that such services must satisfy.
- (d) Pursuant to this Section, PWC's, or its designee's, review and approval of design calculations and design drawings will be only for the limited purpose of checking for conformance with performance and design criteria given and the design concept expressed in the Contract Documents. PWC specifically retains final approval of such submittals.
- (e) Contractor shall not be responsible for the adequacy of the performance or design criteria specified by PWC.

Article VIII. PWC's Responsibilities

- (a) In awarding the bid to Contractor and executing the applicable Agreement, PWC acknowledges the following responsibilities:
 - (i) Except as otherwise provided in these General Conditions, PWC shall issue all communications directly to Contractor or its designee.
 - (ii) PWC may at its discretion replace Design Engineer and Project Engineer. The replacement Design Engineer or Project Engineer's status under the Contract Documents shall be that of the former Design Engineer or Project Engineer.
 - (iii) PWC shall promptly furnish the data required of PWC under the Contract Documents.
 - (iv) PWC shall make payments to Contractor when they are due as provided in the Contract Documents.
 - (v) PWC shall not supervise, direct, or have control or authority over, nor be responsible for, Contractor's means, methods, techniques, sequences, or procedures of construction, or the safety precautions and programs incident thereto, or for any failure of Contractor to comply with Laws and Regulations applicable to the performance of the Work. PWC will not be responsible for Contractor's failure to perform the Work in accordance with the Contract Documents.
 - (vi) Upon request of Contractor, PWC shall furnish to Contractor reasonable evidence that financial arrangements have been made to satisfy PWC's obligations under the Contract Documents (including obligations under proposed changes in the Work).
 - (vii) While at the Site, PWC's employees and representatives shall comply with the specific applicable requirements of Contractor's safety programs of which PWC has been informed.
 - (viii) PWC shall furnish copies of any applicable PWC safety program(s) to Contractor, which Contractor shall review and implement.

Article IX. Amending the Contract Documents; Changes in the Work

Section 9.01 Amending and Supplementing Contract Documents

- (a) The Contract Documents may be amended or supplemented by a Change Order, a Work Change Directive, or a Field Order.
 - (i) Change Orders: If an amendment or supplement to the Contract Documents includes a change in the Contract Price or the Contract Times, such amendment or supplement

General Conditions

must be set forth in a Change Order. A Change Order also may be used to establish amendments and supplements of the Contract Documents that do not affect the Contract Price or Contract Times.

- (ii) **Work Change Directives:** A Work Change Directive will not change the Contract Price or the Contract Times, but is evidence that the parties expect that the modification ordered or documented by a Work Change Directive will be incorporated in a subsequently issued Change Order, following negotiations by the parties as to the Work Change Directive's effect, if any, on the Contract Price and Contract Times; or, if negotiations are unsuccessful, by a determination under the terms of the Contract Documents governing adjustments, expressly including Paragraph 9.04 regarding change of Contract Price. Contractor must submit any Change Proposal seeking an adjustment of the Contract Price or the Contract Times, or both, no later than 30 days after the completion of the Work set out in the Work Change Directive. PWC must submit any dispute or request seeking an adjustment of the Contract Price or the Contract Times, or both, no later than 60 days after issuance of the Work Change Directive.
- (iii) **Field Orders:** Project Engineer may authorize minor changes in the Work if the changes do not involve an adjustment in the Contract Price or the Contract Times and are compatible with the design concept of the completed Project as a functioning whole as indicated by the Contract Documents. Such changes will be accomplished by a Field Order and will be binding on PWC and on Contractor, which shall perform promptly the Work involved. If Contractor believes that a Field Order justifies an adjustment in the Contract Price or Contract Times, or both, then before proceeding with the Work at issue, Contractor shall submit a Change Proposal as provided herein.

Section 9.02 PWC-Authorized Changes in the Work

- (a) Without invalidating the Agreement and without notice to any surety, PWC may, at any time or from time to time, order additions, deletions, or revisions in the Work. Such changes shall be supported by Design Engineer's recommendation when applicable and to the extent the change involves the design (as set forth in the Drawings, Specifications, or otherwise), or other engineering or technical matters. Such changes may be accomplished by a Change Order or by a Work Change Directive. Upon receipt of any such document, Contractor shall promptly proceed with the Work as revised. Nothing in this paragraph shall obligate Contractor to undertake work that Contractor reasonably concludes cannot be performed in a manner consistent with Contractor's safety obligations under the Contract Documents or Laws and Regulations.

Section 9.03 Unauthorized Changes in the Work

- (a) Contractor shall not be entitled to an increase in the Contract Price or an extension of the Contract Times with respect to any work performed that is not required by the Contract Documents, as amended, modified, or supplemented.

Section 9.04 Change of Contract Price

- (a) The Contract Price may only be changed by a Change Order. Any Change Proposal for an adjustment in the Contract Price shall comply with the provisions of these General Conditions.
- (b) An adjustment in the Contract Price will be determined as follows:

General Conditions

- (i) where the Work involved is covered by unit prices contained in the Contract Documents, then by application of such unit prices to the quantities of the items involved; or
 - (ii) where the Work involved is not covered by unit prices contained in the Contract Documents, then by a mutually agreed lump sum (which may include an allowance for overhead and profit as agreed to in writing by the Parties); or
 - (iii) where the Work involved is not covered by unit prices contained in the Contract Documents and the Parties do not reach mutual agreement to a lump sum, then on the basis of the Cost of the Work plus a reasonable Contractor's fee for overhead and profit.
- (c) Contractor's Fee: When applicable, the Contractor's fee for overhead and profit shall be determined as follows:
- (i) a mutually acceptable fixed fee; or
 - (ii) if a fixed fee is not agreed upon, then a fee based on the following percentages of the various portions of the Cost of the Work:
 - 1) for unit prices, the Contractor's fee shall be fifteen percent (15%);
 - 2) for all other costs incurred, the Contractor's fee shall be five percent (5%);
 - 3) the amount of credit to be allowed by Contractor to PWC for any change that results in a net decrease in the Contract Price will be the amount of the actual net decrease in cost plus a deduction in Contractor's fee by an amount equal to five percent of such net decrease; and
 - 4) when both additions and credits are involved in any one change, the adjustment in Contractor's fee shall be computed on the basis of the net change.

Section 9.05 Change of Contract Times

- (a) The Contract Times may only be changed by a Change Order. Any Change Proposal for an adjustment in the Contract Times shall comply with the provisions of Paragraph 9.06.
- (b) An adjustment of the Contract Times shall be subject to the limitations set forth in these Contract Document as it concerns delays in Contractor's progress.

Section 9.06 Change Proposals

- (a) Contractor shall submit a Change Proposal to PWC to request an adjustment in the Contract Times and/or Contract Price. The Change Proposal shall specify any proposed change in Contract Times or Contract Price, or both, or other proposed relief, and explain the reason for the proposed change, with citations to any governing or applicable provisions of the Contract Documents.
 - (i) Procedures: Contractor shall submit each Change Proposal to PWC promptly (but in no event later than 30 days) after the start of the event giving rise thereto, or after such initial decision. The Contractor shall submit supporting data, including the proposed change in Contract Price or Contract Time (if any), to PWC within 15 calendar days after the submittal of the Change Proposal. The supporting data shall be accompanied by a written statement that the supporting data are accurate and complete, and that any requested time or price adjustment is the entire adjustment to which Contractor believes it is entitled as a result of said event.
 - (ii) PWC Action: PWC will review each Change Proposal and, within 30 calendar days after receipt of the Contractor's supporting data, either deny the Change Proposal in whole,

General Conditions

approve it in whole, or deny it in part and approve it in part. Such actions shall be in writing to Contractor. If PWC does not take action on the Change Proposal within 30 calendar days, then the Change Proposal is deemed denied, thereby commencing the time for appeal under these General Conditions.

- (iii) Binding Decision: PWC's decision will be final and binding unless Contractor appeals the decision.

Section 9.07 Execution of Change Orders

- (a) PWC and Contractor shall execute appropriate Change Orders covering:
 - (i) changes in the Contract Price or Contract Times that are agreed to by the parties, including any undisputed sum or amount of time for Work performed in accordance with a Work Change Directive;
 - (ii) changes in Contract Price resulting from a PWC set-off, unless Contractor has duly contested such set-off;
 - (iii) changes in the Work which are: (a) ordered by PWC, (b) required because of PWC's acceptance of defective Work or PWC's correction of defective Work, or (c) agreed to by the parties, subject to the need for Design Engineer's recommendation if the change in the Work involves the design (as set forth in the Contract Documents), or other engineering or technical matters; and
 - (iv) changes in the Contract Price or Contract Times, or other changes, which embody the substance of any final and binding results.
- (b) If PWC or Contractor refuses to execute a Change Order that is required to be executed under the terms of this Section, it shall be deemed to be of full force and effect as if fully executed.

Section 9.08 Notification to Surety

- (a) If the provisions of any bond require notice to be given to a surety of any change affecting the general scope of the Work or the provisions of the Contract Documents (including, but not limited to, Contract Price or Contract Times), the giving of any such notice will be Contractor's responsibility. The amount of each applicable bond will be adjusted to reflect the effect of any such change.

Article X. Tests, Inspections, and Approvals; Correction, Removal, or Acceptance of Defective Work

Section 10.01 Access to Work

- (a) PWC, Design Engineer, their consultants and other representatives and personnel of PWC, independent testing laboratories, and authorities having jurisdiction will have access to the Site and the Work at reasonable times for their observation, inspection, and testing. Contractor shall provide them proper and safe conditions for such access and advise them of Contractor's safety procedures and programs so that they may comply therewith as applicable.

Section 10.02 Tests, Inspections, and Approvals

- (a) Contractor shall give Project Engineer timely notice of readiness of the Work (or specific

General Conditions

parts thereof) for all required inspections and tests and shall cooperate with inspection and testing personnel to facilitate required inspections and tests.

- (b) PWC shall retain and pay for the initial services of an independent inspector, testing laboratory, or other qualified individual or entity to perform all inspections and tests expressly required by the Contract Documents to be furnished and paid for by PWC, except those costs incurred in connection with tests or inspections of covered Work shall be governed by the provisions of Paragraph 10.05.
- (c) If Laws or Regulations of any public body having jurisdiction require any Work (or part thereof) specifically to be inspected, tested, or approved by an employee or other representative of such public body, Contractor shall assume full responsibility for arranging and obtaining such inspections, tests, or approvals, pay all costs in connection therewith, and furnish the required certificates of inspection or approval to PWC.
- (d) Contractor shall be responsible for arranging, obtaining, and paying for all inspections and tests required:
 - (i) by the Contract Documents, unless the Contract Documents expressly allocate responsibility for a specific inspection or test to PWC;
 - (ii) to attain PWC's and Design Engineer's acceptance of materials or equipment to be incorporated in the Work;
 - (iii) by manufacturers of equipment furnished under the Contract Documents;
 - (iv) for testing, adjusting, and balancing of mechanical, electrical, and other equipment to be incorporated into the Work; and
 - (v) for acceptance of materials, mix designs, or equipment submitted for approval prior to Contractor's purchase thereof for incorporation in the Work.

Such inspections and tests shall be performed by independent inspectors, testing laboratories, or other qualified individuals or entities acceptable to PWC, as confirmed in writing by Project Engineer to Contractor.

- (e) If the Contract Documents require the Work (or part thereof) to be approved by PWC or its designee, then Contractor shall assume full responsibility for arranging and obtaining such approvals.
- (f) If any Work (or the work of others) that is to be inspected, tested, or approved is covered by Contractor without written concurrence of Project Engineer, Contractor shall, if requested by Project Engineer, uncover such Work for observation. Such uncovering shall be at Contractor's expense unless Contractor had given PWC timely notice of Contractor's intention to cover the same and PWC had not acted with reasonable promptness in response to such notice.

Section 10.03 Defective Work

- (a) It is Contractor's obligation to assure that the Work is not defective.
- (b) PWC or its designee has the authority to determine whether Work is defective, and to reject defective Work.
- (c) Prompt notice of all defective Work of which PWC has actual knowledge will be given to Contractor.

General Conditions

- (d) Promptly after receipt of written notice of defective Work, Contractor shall correct all such defective Work, whether or not fabricated, installed, or completed, or, if PWC has rejected the defective Work, remove it from the Project and replace it with Work that is not defective.
- (e) When correcting defective Work, Contractor shall take no action that would void or otherwise impair PWC's special warranty and guarantee, if any, on said Work.
- (f) In addition to its correction, removal, and replacement obligations with respect to defective Work, Contractor shall pay all claims, costs, losses, and damages arising out of or relating to defective Work, including but not limited to the cost of the inspection, testing, correction, removal, replacement, or reconstruction of such defective Work, fines levied against PWC by governmental authorities because the Work is defective, and the costs of repair or replacement of work of others resulting from defective Work. Prior to final payment, if PWC and Contractor are unable to agree as to the measure of such claims, costs, losses, and damages resulting from defective Work, then PWC may impose a reasonable set-off against payments due.

Section 10.04 Acceptance of Defective Work

- (a) If, instead of requiring correction or removal and replacement of defective Work, PWC prefers to accept it, PWC may do so (subject, if such acceptance occurs prior to final payment, to Design Engineer's confirmation that such acceptance is in general accord with the design intent and applicable engineering principles and will not endanger public safety).
- (b) Contractor shall pay all claims, costs, losses, and damages attributable to PWC's evaluation of and determination to accept such defective Work (such costs to be approved by PWC as to reasonableness), and for the diminished value of the Work to the extent not otherwise paid by Contractor. If any such acceptance occurs prior to final payment, the necessary revisions in the Contract Documents with respect to the Work shall be incorporated in a Change Order.
- (c) If the parties are unable to agree as to the decrease in the Contract Price, reflecting the diminished value of Work so accepted, then PWC may impose a reasonable set-off against payments due. If the acceptance of defective Work occurs after final payment, Contractor shall pay an appropriate amount to PWC.

Section 10.05 Uncovering Work

- (a) PWC has discretion to require, at its initial cost, additional inspection or testing of the Work, whether or not the Work is fabricated, installed, or completed.
- (b) If any Work is covered contrary to the written request of PWC, then Contractor shall, if requested by PWC or its designee, uncover such Work for observation, and then replace the covering, all at Contractor's expense.
- (c) If PWC considers it necessary or advisable that covered Work be observed by PWC or inspected or tested by others, then Contractor, at PWC's request, shall uncover, expose, or otherwise make available for observation, inspection, or testing as PWC may require, that portion of the Work in question, and provide all necessary labor, material, and equipment.

General Conditions

- (i) If it is found that the uncovered Work is defective, Contractor shall be responsible for all claims, costs, losses, and damages arising out of or relating to such uncovering, exposure, observation, inspection, and testing, and of satisfactory replacement or reconstruction (including but not limited to all costs of repair or replacement of work of others); and pending Contractor's full discharge of this responsibility PWC shall be entitled to impose a reasonable set-off against payments due.
- (ii) If the uncovered Work is not found to be defective, Contractor shall be allowed an increase in the Contract Price or an extension of the Contract Times, or both, directly attributable to such uncovering, exposure, observation, inspection, testing, replacement, and reconstruction. If the parties are unable to agree as to the amount or extent thereof, then Contractor may submit a Change Proposal within 30 calendar days of the determination that the Work is not defective.

Section 10.06 PWC May Stop the Work

- (a) If the Work is defective, or Contractor fails to supply sufficiently skilled workers or suitable materials or equipment, or fails to perform the Work in such a way that the completed Work will conform to the Contract Documents, then PWC may order Contractor to stop the Work, or any portion thereof, until the cause for such order has been eliminated; however, this right of PWC to stop the Work shall not give rise to any duty on the part of PWC to exercise this right for the benefit of Contractor, any Subcontractor, any Supplier, any other individual or entity, or any surety for, or employee or agent of any of them.

Section 10.07 PWC May Correct Defective Work

- (a) If Contractor fails within the time specified by PWC in a written notice from PWC to correct defective Work, or to remove and replace rejected Work as required by PWC, or if Contractor fails to perform the Work in accordance with the Contract Documents, or if Contractor fails to comply with any other provision of the Contract Documents, then PWC may, after seven (7) calendar days written notice to Contractor, correct or remedy any such deficiency.
- (b) In exercising the rights and remedies under this Section, PWC shall proceed expeditiously. In connection with such corrective or remedial action, PWC may exclude Contractor from all or part of the Site, take possession of all or part of the Work and suspend Contractor's services related thereto, and incorporate in the Work all materials and equipment stored at the Site or for which PWC has paid Contractor but which are stored elsewhere. Contractor shall allow PWC and its officers, employees, representatives, agents and other contractors, and Design Engineer and its employees and agents access to the Site to enable PWC to exercise the rights and remedies under this Section.
- (c) All claims, costs, losses, and damages incurred or sustained by PWC in exercising the rights and remedies under this Section will be charged against Contractor as set-offs against payments due. Such claims, costs, losses and damages will include but not be limited to all costs of repair, or replacement of work of others destroyed or damaged by correction, removal, or replacement of Contractor's defective Work.
- (d) Contractor shall not be allowed an extension of the Contract Times because of any delay in the performance of the Work attributable to the exercise by PWC of PWC's rights and remedies under this Section.

Article XI. Claims

Section 11.01 Claims Process

- (a) The following disputes between PWC and Contractor shall be submitted to the Claims process set forth in this Article:
 - (i) Appeals by PWC or Contractor of Design Engineer's decisions regarding Change Proposals;
 - (ii) PWC or Contractor's demands for adjustments in the Contract Price or Contract Times, or other relief under the Contract Documents; and
 - (iii) Disputes that Design Engineer has been unable to address because they do not involve the design (as set forth in the Contract Documents), the acceptability of the Work, or other engineering or technical matters.

Section 11.02 Submittal of Claim

- (a) The party submitting a claim shall deliver it directly to the other party to the Agreement promptly (but in no event later than 30 calendar days) after the start of the event giving rise thereto; in the case of appeals regarding Change Proposals within 30 calendar days of the decision under appeal. The responsibility to substantiate a claim shall rest with the party making the claim. In the case of a claim by Contractor seeking an increase in the Contract Times or Contract Price, or both, Contractor shall certify that the claim is made in good faith, that the supporting data are accurate and complete, and that to the best of Contractor's knowledge and belief the amount of time or money requested accurately reflects the full amount to which Contractor is entitled.

Section 11.03 Review and Resolution

- (a) The party receiving a Claim shall review it thoroughly, giving full consideration to its merits. The two parties shall seek to resolve the Claim through the exchange of information and direct negotiations. The parties may extend the time for resolving the Claim by mutual agreement. All actions taken on a Claim shall be stated in writing and submitted to the other party.

Section 11.04 Dispute Resolution

- (a) In the event of any dispute, controversy, or claim of any kind or nature arising under or in connection with this Agreement (a "Dispute") and involving any two or more of the following parties, PWC, Design Engineer, Contractor or any subcontractor of Contractor, the party initiating the Dispute shall serve written notice of a Dispute on the party(ies) to the dispute, and those parties shall endeavor to settle the dispute first through direct, informal discussions between the parties' selected representatives. Any such representative(s) shall have binding authority to settle the Dispute. In the event the parties do not settle the Dispute within ten (10) calendar days from the date of written notice of the Dispute, any party to the Dispute may, by written notice to the other party(ies), engage a mediator certified under the laws of the State of North Carolina to mediate the Dispute within thirty (30) calendar days of such notice. The parties to the Dispute shall attend mediation in good faith. In the event mediation is unsuccessful, any party to the dispute may initiate arbitration proceedings. Any controversy or claim arising out of or relating to the Contract Documents, or the breach thereof, shall be settled by binding arbitration administered by

General Conditions

the American Arbitration Association under its Construction Industry Arbitration Rules, and judgment on the award rendered by the arbitrator(s) may be entered in any court having jurisdiction thereof. All of the foregoing dispute resolution procedures shall be held in Cumberland County, North Carolina. The costs of the mediator and arbitrator in a dispute resolution process shall be divided equally among the parties to the process; provided, however, PWC shall bear at least one-third of the cost if PWC is a party to the dispute resolution and the remainder of the cost shall be divided equally among the other parties participating in the dispute resolution. PWC shall, in its contractual arrangements with Design Engineer, and Contractor shall, in its contracts with Subcontractors and they in their contracts with lower-tier subcontractors authorize and direct such parties to participate in the dispute resolution procedures set forth in this Section. Unless otherwise directed in writing by PWC, Contractor shall continue the Project and maintain compliance with the scheduling deadlines set forth in the Contract Documents during any dispute resolution proceedings. If Contractor continues to perform, PWC shall make payments due for the continued performance in accordance with this Agreement. The provisions of this Section shall not extend any applicable statutes of limitation or repose.

Article XII. Payments to Contractor; Set-Offs; Completion; Correction Period

Section 12.01 Progress Payments

- (a) The Schedule of Values will serve as the basis for progress payments and will be incorporated into a form of Application for Payment acceptable to the Project Engineer. Progress payments on account of Unit Price Work will be based on the number of units completed during the pay period. Progress payments for cost-based Work will be based on the Cost of the Work completed by the Contractor during the pay period.
- (b) Applications for Payments:
 - (i) Contractor shall submit to Project Engineer for review an Application for Payment filled out and signed by Contractor covering the Work completed as of the date of the Application and accompanied by such supporting documentation as is required by the Contract Documents. If payment is requested on the basis of materials and equipment not incorporated in the Work but delivered and suitably stored at the Site or another location agreed to in writing, the Application for Payment shall also be accompanied by a bill of sale, invoice, or other documentation warranting that PWC has received the materials and equipment free and clear, and evidence that the materials and equipment are covered by appropriate property insurance, a warehouse bond, or other arrangements to protect PWC's interest.
 - (ii) Beginning with the second Application for Payment, each Application shall include an affidavit of Contractor stating that all previous progress payments received on account of the Work have been applied on account to discharge Contractor's legitimate obligations associated with prior Applications for Payment.
 - (iii) The amount of retainage for progress payments will be as stipulated in the Contract Documents.
- (c) Review of Applications:
 - (i) Project Engineer will, within ten (10) Business Days after receipt of each Application for Payment, including each resubmittal, either indicate in writing a recommendation of

General Conditions

payment and present the Application to PWC, or return the Application to Contractor indicating in writing Project Engineer's reason(s) for refusing to recommend payment. In the latter case, the Contractor may make the necessary corrections and resubmit the Application.

- (ii) Project Engineer's recommendation of any payment requested in an Application for Payment will constitute a representation by Project Engineer to PWC, based on Project Engineer's observations of the executed Work, and on Project Engineer's review of the Application for Payment and the accompanying data and schedules, that to the best of Project Engineer's knowledge, information, and belief:
 - 1) the Work has progressed to the point indicated;
 - 2) the quality of the Work is generally in accordance with the Contract Documents (subject to an evaluation of the Work as a functioning whole prior to or upon Substantial Completion, the results of any subsequent tests called for in the Contract Documents, a final determination of quantities and classifications for Unit Price Work, and any other qualifications stated in the recommendation); and
 - 3) the conditions precedent to Contractor's being entitled to such payment appear to have been fulfilled in so far as it is Project Engineer's responsibility to observe the Work.
- (iii) By recommending any such payment Project Engineer will not thereby be deemed to have represented that:
 - 1) inspections made to check the quality or the quantity of the Work as it has been performed have been exhaustive, extended to every aspect of the Work in progress, or involved detailed inspections of the Work beyond the responsibilities specifically assigned to Project Engineer in the Contract Documents; or
 - 2) there may not be other matters or issues between the parties that might entitle Contractor to be paid additionally by PWC or entitle PWC to withhold payment to Contractor.
- (iv) Neither Project Engineer's review of Contractor's Work for the purposes of recommending payments nor Project Engineer's recommendation of any payment, including final payment, will impose responsibility on Project Engineer:
 - 1) to supervise, direct, or control the Work, or
 - 2) for the means, methods, techniques, sequences, or procedures of construction, or the safety precautions and programs incident thereto, or
 - 3) for Contractor's failure to comply with Laws and Regulations applicable to Contractor's performance of the Work, or
 - 4) to make any examination to ascertain how or for what purposes Contractor has used the money paid on account of the Contract Price.
- (v) Project Engineer may refuse to recommend the whole or any part of any payment if, in Project Engineer's opinion, it would be incorrect to make the representations to PWC outlined in this Section.
- (d) Project Engineer will recommend reductions in payment (set-offs) necessary in Project Engineer's opinion to protect PWC from loss because:
 - (i) the Work is defective, requiring correction or replacement;
 - (ii) the Contract Price has been reduced by Change Orders;
 - (iii) PWC has been required to correct defective Work or has accepted defective Work in

General Conditions

- accordance with these General Conditions;
- (iv) PWC has been required to remove or remediate a Hazardous Environmental Condition for which Contractor is responsible; or
 - (v) Project Engineer has actual knowledge of the occurrence of any of the events that would constitute a default by Contractor and therefore justify termination for cause under the Contract Documents.
- (e) Payment Becomes Due:
- (i) Twenty (20) Business Days after presentation of the Application for Payment to PWC with Project Engineer's recommendation, the amount recommended (subject to any PWC set offs) will become due, and when due will be paid by PWC to Contractor.
- (f) Reductions in Payment by PWC:
- (i) In addition to any reductions in payment (set-offs) recommended by Project Engineer, PWC is entitled to impose a set-off against payment based on any of the following:
 - 1) PWC has incurred costs, losses, or damages on account of Contractor's conduct in the performance or furnishing of the Work, including but not limited to claims, costs, losses, or damages from workplace injuries, adjacent property damage, non-compliance with Laws and Regulations, and patent infringement;
 - 2) Contractor has failed to take reasonable and customary measures to avoid damage, delay, disruption, and interference with other work at or adjacent to the Site;
 - 3) Contractor has failed to provide and maintain required bonds or insurance;
 - 4) PWC has been required to remove or remediate a Hazardous Environmental Condition for which Contractor is responsible;
 - 5) PWC has incurred extra charges or engineering costs related to submittal reviews, evaluations of proposed substitutes, tests and inspections, or return visits to manufacturing or assembly facilities;
 - 6) the Work is defective, requiring correction or replacement;
 - 7) PWC has been required to correct defective Work or has accepted defective Work in accordance with the Contract Documents;
 - 8) the Contract Price has been reduced by Change Orders;
 - 9) an event that would constitute a default by Contractor and therefore justify a termination for cause has occurred;
 - 10) liquidated damages have accrued as a result of Contractor's failure to achieve Milestones, Substantial Completion, or Completion of the Project; or
 - 11) there are other items entitling PWC to a set off against the amount recommended.
 - (ii) If PWC imposes any set-off against payment, whether based on its own knowledge or on the written recommendations of Project Engineer, PWC will give Contractor immediate written notice stating the reasons for such action and the specific amount of the reduction, and promptly pay Contractor any amount remaining after deduction of the amount so withheld. PWC shall promptly pay Contractor the amount so withheld, or any adjustment agreed to by PWC and Contractor if Contractor remedies the reasons for such action. The reduction imposed shall be binding on Contractor unless it duly submits a Change Proposal contesting the reduction.
 - (iii) Upon a subsequent determination that PWC's refusal of payment was not justified, the amount wrongfully withheld shall be treated as an amount due and subject to interest as provided in the Contract Documents.

General Conditions

Section 12.02 Substantial Completion

- (a) When Contractor considers the entire Work ready for its intended use Contractor shall notify PWC and Design Engineer in writing that the entire Work is substantially complete and request that PWC acknowledge in writing that Contractor has met Substantial Completion.
- (b) Promptly after Contractor's notification, PWC, Contractor, and Design Engineer shall make an inspection of the Work to determine the status of completion. If PWC does not consider the Work substantially complete, PWC will notify Contractor in writing giving the reasons therefor. PWC shall thereafter submit to Contractor an initial draft of punch list items to be completed or corrected before final payment.
- (c) If Design Engineer considers the Work substantially complete, Design Engineer will deliver to PWC a preliminary certificate of Substantial Completion which shall fix the date of Substantial Completion. Design Engineer shall attach to the certificate a punch list of items to be completed or corrected before final payment. PWC shall have seven (7) Business Days after receipt of the preliminary certificate to make written objection to Design Engineer as to any provisions of the certificate or attached punch list. If, after considering the objections to the provisions of the preliminary certificate, PWC concludes that the Work is not substantially complete, PWC will, within fourteen (14) calendar days after submission of the preliminary certificate to PWC, notify Contractor in writing that the Work is not substantially complete, stating the reasons therefor.
- (d) At the time of receipt of the preliminary certificate of Substantial Completion, PWC and Contractor will confer regarding PWC's use or occupancy of the Work following Substantial Completion, review the builder's risk insurance policy with respect to the end of the builder's risk coverage, and confirm the transition to coverage of the Work under a permanent property insurance policy held by PWC. Unless PWC and Contractor agree otherwise in writing, PWC shall bear responsibility for security, operation, protection of the Work, property insurance, maintenance, heat, and utilities upon PWC use or occupancy of the Work.
- (e) After Substantial Completion the Contractor shall promptly begin work on the punch list of items to be completed or corrected prior to final payment and shall complete such items within the time specified by PWC. In appropriate cases Contractor may submit monthly Applications for Payment for completed punch list items, following the progress payment procedures set forth above.
- (f) PWC shall have the right to exclude Contractor from the Site after the date of Substantial Completion subject to allowing Contractor reasonable access to remove its property and complete or correct items on the punch list.

Section 12.03 Partial Use or Occupancy

- (a) Prior to Substantial Completion of all the Work, PWC may use or occupy any substantially completed part of the Work which has specifically been identified in the Contract Documents, or which PWC, Design Engineer, and Contractor agree constitutes a separately functioning and usable part of the Work that can be used by PWC for its intended purpose without significant interference with Contractor's performance of the remainder of the Work, subject to the following conditions:

General Conditions

- (i) At any time PWC may request in writing that Contractor permit PWC to use or occupy any such part of the Work that PWC believes to be substantially complete.
- (ii) At any time Contractor may notify PWC and Design Engineer in writing that Contractor considers any such part of the Work substantially complete and request Design Engineer to issue a certificate of Substantial Completion for that part of the Work.
- (iii) Within a reasonable time after either such request, PWC, Contractor, and Design Engineer shall make an inspection of that part of the Work to determine its status of completion. If Design Engineer does not consider that part of the Work to be substantially complete, Design Engineer will notify PWC and Contractor in writing giving the reasons therefor.
- (iv) No use or occupancy or separate operation of part of the Work may occur prior to compliance with the requirements regarding builder's risk or other property insurance.

Section 12.04 Final Inspection

- (a) Upon written notice from Contractor that Completion of the Project has been achieved or an agreed portion thereof is complete, PWC will promptly make a final inspection with Project Engineer, Design Engineer, and Contractor and will notify Contractor in writing of all particulars in which this inspection reveals that the Work, or agreed portion thereof, is incomplete or defective. Contractor shall immediately take such measures as are necessary to complete such Work or remedy such deficiencies.

Section 12.05 Final Payment

- (a) Application for Payment:
 - (i) After Contractor has, in the opinion of PWC, satisfactorily completed all corrections identified during the final inspection and has delivered, in accordance with the Contract Documents, all maintenance and operating instructions, schedules, guarantees, bonds, certificates or other evidence of insurance, certificates of inspection, annotated record documents, and other documents, Contractor may make application for final payment.
 - (ii) The final Application for Payment shall be accompanied (except as previously delivered) by:
 - 1) all documentation called for in the Contract Documents;
 - 2) consent of the surety, if any, to final payment;
 - 3) satisfactory evidence that all title issues have been resolved such that title to all Work, materials, and equipment has passed to PWC free and clear or will so pass upon final payment;
 - 4) a list of all disputes that Contractor believes are unsettled; and
 - 5) complete and legally effective releases or waivers (satisfactory to PWC) required by the Contract Documents.
 - (iii) If Design Engineer is satisfied that the Work has been completed and Contractor's other obligations under the Contract have been fulfilled, Design Engineer will, within ten (10) Business Days after receipt of the final Application for Payment, indicate in writing Design Engineer's recommendation of final payment and present the Application for Payment to PWC for payment. Such recommendation shall account for any set-offs against payment that are necessary in Design Engineer's opinion to protect PWC from loss for the reasons stated above with respect to progress payments. At the same time Design Engineer will also give written notice to PWC and Contractor that the Work is acceptable and that

General Conditions

Completion of the Project has been achieved. Otherwise, Design Engineer will return the Application for Payment to Contractor, indicating in writing the reasons for refusing to recommend final payment, in which case Contractor shall make the necessary corrections and resubmit the Application for Payment.

- (iv) Within thirty (30) calendar days after the presentation to PWC of the final Application for Payment and accompanying documentation, the amount recommended by Design Engineer (less any further sum PWC is entitled to set off against Design Engineer's recommendation, including but not limited to set-offs for liquidated damages and set-offs allowed under the provisions above with respect to progress payments) will become due and shall be paid by PWC to Contractor.

Section 12.06 Waiver of Claims

- (a) The making of final payment will not constitute a waiver by PWC of claims or rights against Contractor. PWC expressly reserves claims and rights arising from defective Work appearing after final inspection, from Contractor's failure to comply with the Contract Documents or the terms of any special guarantees specified therein, from Contractor's indemnification obligations, or from Contractor's continuing obligations under the Contract Documents.
- (b) The acceptance of final payment by Contractor will constitute a waiver by Contractor of all claims and rights against PWC other than those pending matters that have been duly submitted or appealed under the provisions of the Contract Documents.

Section 12.07 Correction Period

- (a) If within one (1) year after the date of Substantial Completion (or such longer period of time as may be prescribed by the terms of any applicable special guarantee required by the Contract Documents, or by any specific provision of the Contract Documents), any Work is found to be defective, or if the repair of any damages to the Site, adjacent areas that Contractor has arranged to use through construction easements or otherwise, and other adjacent areas used by Contractor as permitted by Laws and Regulations, is found to be defective, then Contractor shall promptly, without cost to PWC and in accordance with PWC's written instructions:
 - (i) correct the defective repairs to the Site or such other adjacent areas;
 - (ii) correct such defective Work;
 - (iii) if the defective Work has been rejected by PWC, remove it from the Project and replace it with Work that is not defective, and
 - (iv) satisfactorily correct or repair or remove and replace any damage to other Work, to the work of others, or to other land or areas resulting therefrom.
- (b) If Contractor does not promptly comply with the terms of PWC's written instructions, or in an emergency where delay would cause serious risk of loss or damage, PWC may have the defective Work corrected or repaired or may have the rejected Work removed and replaced. Contractor shall pay all claims, costs, losses, and damages (including but not limited to all fees and charges of engineers, architects, attorneys, and other professionals and all court or arbitration or other dispute resolution costs) arising out of or relating to such correction or repair or such removal and replacement (including but not limited to all costs of repair or replacement of work of others).
- (c) In special circumstances where a particular item of equipment is placed in continuous

General Conditions

service before Substantial Completion of all the Work, the correction period for that item may start to run from an earlier date only as provided in the Contract Documents.

- (d) Where defective Work (and damage to other Work resulting therefrom) has been corrected or removed and replaced under this Article XII, the correction period hereunder with respect to such Work will be extended for an additional period of one year after such correction or removal and replacement has been satisfactorily completed.
- (e) Contractor's obligations under this Article XII are in addition to all other obligations and warranties. The provisions of this Article XII shall not be construed as a substitute for, or a waiver of, the provisions of any applicable statute of limitation or repose.

Article XIII. Suspension of Work and Termination

Section 13.01 PWC May Suspend Work

- (a) At any time and without cause, PWC may suspend the Work or any portion thereof for a period of not more than 90 consecutive calendar days by written notice to Contractor and Design Engineer. Such notice will fix the date on which Work will be resumed. Contractor shall resume the Work on the date so fixed. Contractor shall be entitled to an adjustment in the Contract Price or an extension of the Contract Times, or both, directly attributable to any such suspension. Any Change Proposal seeking such adjustments shall be submitted no later than thirty (30) calendar days after the date fixed for resumption of Work.

Section 13.02 PWC May Terminate for Cause

- (a) The occurrence of any one or more of the following events will constitute a default by Contractor and justify termination for cause:
 - (i) Contractor's continued failure to perform the Work in accordance with the Contract Documents (including, but not limited to, failure to supply sufficient skilled workers or suitable materials or equipment or failure to adhere to the Progress Schedule);
 - (ii) Failure of Contractor to perform or otherwise to comply with a material term of the Contract Documents;
 - (iii) Contractor's disregard of Laws or Regulations of any public body having jurisdiction; or
 - (iv) Contractor's repeated disregard of the authority of PWC, Project Engineer, or Design Engineer.
- (b) If one or more of the events identified in Paragraph 13.02(a) occurs, then after giving Contractor (and any surety) ten (10) calendar days written notice that PWC is considering a declaration that Contractor is in default and termination of the Agreement, PWC may proceed to:
 - (i) declare Contractor to be in default, and give Contractor (and any surety) notice that the Contract is terminated; and
 - (ii) enforce the rights available to PWC under any applicable performance bond.
- (c) Subject to the terms and operation of any applicable performance bond, if PWC has terminated the Contract for cause, PWC may exclude Contractor from the Site, take possession of the Work, incorporate in the Work all materials and equipment stored at the Site or for which PWC has paid Contractor but which are stored elsewhere, and complete the Work as PWC may deem expedient.

General Conditions

- (d) PWC may not proceed with termination of the Contract under Paragraph 13.02(b) if Contractor within seven (7) calendar days of receipt of notice of intent to terminate begins to correct its failure to perform and proceeds diligently to cure such failure and such efforts are agreed to by PWC.
- (e) If PWC proceeds as provided in Paragraph 13.02(b), Contractor shall not be entitled to receive any further payment until the Work is completed. If the unpaid balance of the Contract Price exceeds the cost to complete the Work, including all related claims, costs, losses, and damages (including but not limited to all fees and charges of engineers, architects, attorneys, and other professionals) sustained by PWC, such excess will be paid to Contractor. If the cost to complete the Work including such related claims, costs, losses, and damages exceeds such unpaid balance, Contractor shall pay the difference to PWC. Such claims, costs, losses, and damages incurred by PWC will be reviewed by PWC as to their reasonableness and, when so approved by PWC, incorporated in a Change Order.
- (f) Where Contractor's services have been so terminated by PWC, the termination will not affect any rights or remedies of PWC against Contractor then existing or which may thereafter accrue, or any rights or remedies of PWC against Contractor or any surety under any payment bond or performance bond. Any retention or payment of money due Contractor by PWC will not release Contractor from liability.
- (g) The provisions of any applicable payment or performance bond shall govern over any inconsistent provisions of this Section.

Section 13.03 PWC May Terminate For Convenience

- (a) Upon seven (7) calendar days written notice to Contractor, PWC may, without cause and without prejudice to any other right or remedy of PWC, terminate the Contract. In such case, Contractor shall be paid for (without duplication of any items):
 - (i) completed and acceptable Work executed in accordance with the Contract Documents prior to the effective date of termination, including fair and reasonable sums for overhead and profit on such Work;
 - (ii) expenses sustained prior to the effective date of termination in performing services and furnishing labor, materials, or equipment as required by the Contract Documents in connection with uncompleted Work, plus fair and reasonable sums for overhead and profit on such expenses; and
 - (iii) other reasonable expenses directly attributable to termination, including costs incurred to prepare a termination for convenience cost proposal.
- (b) Contractor shall not be paid on account of loss of anticipated overhead, profits, or revenue, or other economic loss arising out of or resulting from such termination.

Section 13.04 Contractor May Stop Work or Terminate

- (a) If, through no act or fault of Contractor, (1) the Work is suspended for more than ninety (90) consecutive calendar days by PWC or under an order of court or other public authority or (2) PWC fails for sixty (60) calendar days to pay Contractor any sum finally determined to be due, then Contractor may, upon seven (7) calendar days written notice to PWC, and provided PWC does not remedy such suspension or failure within that time, terminate the Contract and recover from PWC payment on the same terms as provided in this Article.

General Conditions

- (b) In lieu of terminating the Contract and without prejudice to any other right or remedy, if PWC has failed for thirty (30) calendar days to pay Contractor any sum finally determined to be due, Contractor may, seven (7) calendar days after written notice to PWC, stop the Work until payment is made of all such amounts due Contractor, including interest thereon. The provisions of this paragraph are not intended to preclude Contractor from submitting a Change Proposal for an adjustment in Contract Price or Contract Times or otherwise for expenses or damage directly attributable to Contractor's stopping the Work as permitted by this paragraph.

Section 13.05 Morality

- (a) If, in the sole opinion of PWC, at any time Contractor or any of its owner(s) or employee(s) or agent(s) (each party, owner, employee, and agent is an "Actor") engages in any one or more actions that bring disrepute, contempt, scandal, or public ridicule to the Actor or subject the Actor to prosecution or offend the community or public morals or decency or denigrate individuals or groups in the community served by PWC or are scandalous or inconsistent with community standards or good citizenship or may adversely affect PWC's finances, public standing, image, or reputation or are embarrassing or offensive to PWC or may reflect unfavorably on PWC or are derogatory or offensive to one or more employee(s) or customer(s) of PWC, PWC may immediately upon written notice to Contractor terminate the Agreement, in addition to any other rights and remedies that PWC may have pursuant to the Contract Documents or at law or in equity.

Article XIV. Miscellaneous

Section 14.01 Additional General Terms and Conditions

- (a) Contractor shall be subject to any additional terms and conditions for this Project as set forth in the applicable Appendices as specific in the Agreement, which is incorporated by reference as if set forth word-for-word herein.

Section 14.02 Giving Notice

- (a) Whenever any provision of the Contract Documents requires the giving of written notice, it will be deemed to have been validly given if:
 - (i) delivered in person, by a commercial courier service or otherwise, to the individual or to a member of the firm or to an officer of the corporation for which it is intended;
 - (ii) delivered at or sent by registered or certified mail, postage prepaid, to the last business address known to the sender of the notice; or
 - (iii) sent to PWC or Contractor's designee(s) via email, with a confirmation of receipt.

Section 14.03 Computation of Times

- (a) When any period of time is referred to in the Contract by days, it will be computed to exclude the first and include the last day of such period. If the last day of any such period falls on a Saturday or Sunday or on a day made a legal holiday by the law of the applicable jurisdiction, such day will be omitted from the computation.

Section 14.04 Cumulative Remedies

General Conditions

- (a) The duties and obligations imposed by these General Conditions and the rights and remedies available hereunder to the parties are in addition to, and are not to be construed in any way as a limitation of, any rights and remedies available to any or all of them which are otherwise imposed or available by Laws or Regulations, by special warranty or guarantee, or by other provisions of the Contract Documents. The provisions of this paragraph will be as effective as if repeated specifically in the Contract Documents in connection with each particular duty, obligation, right, and remedy to which they apply.

Section 14.05 Limitation of Damages

- (a) With respect to any and all Change Proposals, Claims, disputes subject to final resolution, and other matters at issue, neither PWC nor Design Engineer, nor any of their officers, directors, members, partners, employees, agents, consultants, or subcontractors, shall be liable to Contractor for any claims, costs, losses, or damages sustained by Contractor on or in connection with any other project or anticipated project.

Section 14.06 No Waiver

- (a) A party's non-enforcement of any provision shall not constitute a waiver of that provision, nor shall it affect the enforceability of that provision or any other provision of the Contract Documents.

Section 14.07 Survival of Obligations

- (a) All representations, indemnifications, warranties, and guarantees made in, required by, or given in accordance with the Contract Documents, as well as all continuing obligations indicated in the Contract Documents, will survive final payment, completion, and acceptance of the Work or termination or completion of the Agreement or termination of the services of Contractor.

Section 14.08 Controlling Law

- (a) The Agreement shall be governed by the law of the State of North Carolina.

Section 14.09 Headings

- (a) Article and paragraph headings, numbers, and letters are inserted for convenience only and do not constitute parts of these General Conditions.

PERFORMANCE BOND

Date of Execution: _____

Name of Principal: _____
(Contractor)

Name of Surety: _____

Name of Contracting
Body: Fayetteville Public Works Commission, Fayetteville, N.C.

Amount of Bond: _____

PROJECT: AST SYSTEM CONVERSION TO UST SYSTEM

KNOW ALL MEN BY THESE PRESENTS, That We, the Principal and Surety above named, are held and firmly bound unto the above named Contracting Body, hereinafter called the Contracting Body, in the penal sum of the amount stated above the payment of which sum well and truly to be made, we bind ourselves, our heirs, executors, administrators, and successors, jointly and severally, firmly by these present.

THE CONDITION OF THIS OBLIGATION IS SUCH that whereas the Principal entered into a certain Contract with the Contracting Body, identified as shown above and hereto attached.

NOW, THEREFORE, if the Principal shall well and truly perform and fulfill all the undertakings, covenants, terms, conditions, and agreements of said Contract during the original term of said Contract and any extensions there of that may be granted by the Contracting Body, with or without notice to the Surety, and during the life of any Guaranty required under the Contract, and shall also well and truly perform and fulfill all the undertakings, covenants, terms, conditions, and agreements of any and all duly authorized modifications of said Contract that may hereafter be made, notice of which modifications to the Surety being hereby waived, then, this obligation to be void; otherwise to remain in full force and virtue.

IN WITNESS WHEREOF, the above bounded parties have executed this instrument under the several seals on the date indicated above, the name and corporate seal of each corporate party being hereto affixed, and these presents duly signed by its undersigned representative, pursuant to authority of its governing body.

Executed in _____ counterparts.

Witness:

(Proprietorship of Partnership)

By:

Title:

(Corporate Secretary or
Assistant Secretary, Only)

CONTRACTOR:

(Trade or Corporate Name)

By:

Title:

(Owner, Partner, Corporate President or
Vice-President, Only)
(CORPORATE SEAL)

Witness:

Countersigned:

(N.C. Licensed Resident Agent)

SURETY COMPANY:

(Surety Company Name)

By:

Title:

(Attorney in Fact)
(SURETY CORPORATE SEAL)

PAYMENT BOND

Date of Execution: _____

Name of Principal: _____
(Contractor)

Name of Surety: _____

Name of Contracting
Body: Fayetteville Public Works Commission, Fayetteville, N.C.

Amount of Bond: _____

PROJECT: AST SYSTEM CONVERSION TO UST SYSTEM

KNOW ALL MEN BY THESE PRESENTS, that We, the PRINCIPAL and Surety above named, are held and firmly bound unto the above named Contracting Body, hereinafter called the Contracting Body, in the penal sum of the amount stated above the payment of which sum well and truly to be made, we bind ourselves, our heirs, executors, administrators, and successors, jointly and severally, firmly by these presents.

THE CONDITION OF THIS OBLIGATION IS SUCH that whereas the Principal entered into a certain Contract with the Contracting Body, identified as shown above and hereto attached.

NOW THEREFORE, if the Principal shall promptly make payment to all persons supplying labor and material in the prosecution of the work provided for in said contract, and any and all duly authorized modifications of said contract that may hereafter be made, notice of which modifications to the Surety being hereby waived, then, this obligation to be void; otherwise to remain in full force and virtue.

IN WITNESS WHEREOF, the above bounded parties have executed this instrument under the several seals on the date indicated above, the name and corporate seal of each corporate party being hereto affixed, and these presents duly signed by its undersigned representative, pursuant to authority of its governing body.

Executed in _____ counterparts.

Witness:

CONTRACTOR:

(Proprietorship of Partnership)

(Trade or Corporate Name)

By:

By:

Title:

Title:

(Corporate Secretary or
Assistant Secretary, Only)

(Owner, Partner, Corporate President or
Vice-President, Only)
(CORPORATE SEAL)

Witness:

SURETY COMPANY:

(Surety Company Name)

By:

Countersigned:

Title:

(N.C. Licensed Resident Agent)

(Attorney in Fact)
(SURETY CORPORATE SEAL)

**POWER OF ATTORNEY
(ATTACH)**

**CERTIFICATE(S) OF INSURANCE
(Attach)**

NOTICE TO PROCEED

TO: _____

Date: _____

PROJECT: **AST SYSTEM CONVERSION TO UST SYSTEM**

You are hereby notified to commence work in accordance with the Contract dated _____, 2023, on or before _____, 2023, and you are to complete the WORK within the **contract period** thereafter. The date of final completion therefore is _____.

FAYETTEVILLE PUBLIC WORKS COMMISSION

BY: _____

Tanga Anderson-Solomon
Procurement Manager

ACCEPTANCE OF NOTICE

Receipt of the above NOTICE TO PROCEED is hereby acknowledged this the _____ day of _____, 2023.

(CONTRACTOR)

BY: _____

TITLE: _____

- END OF SECTION -

SECTION C - ADMINISTRATIVE PROVISIONS

***** THIS PAGE WAS INTENTIONALLY LEFT BLANK *****

**DIVISION I
01000 – SUPPLEMENTARY CONDITIONS**

DEFINITIONS & TERMINOLOGY

1. “Owner” - Fayetteville Public Works Commission
2. “Emergency Dispatcher” - An employee of PWC who is on-site 24 hours.
3. “Contract Drawings” – Drawings sealed by a Professional Engineer and released with the RFP package for bid purposes.
4. “Fayetteville Public Works Commission’s Consultant” - Professional Engineering Firm, Haggett Engineering, hired by Fayetteville Public Works for the design of the AST System Conversion to UST System conversion.

GENERAL

These Supplementary Conditions are intended to supplement and amplify the Technical Specifications and other requirements of the Contract Documents. Where any article or item of the Contract Documents is modified or deleted by this document, the remaining unaltered provisions of that article, paragraph, subparagraph, or clause shall remain in effect. In the event of a conflict, these Supplementary Conditions shall take precedence.

Unless otherwise noted, all items in these Supplementary Conditions shall be considered incidental to the Work, and no additional payment will be made for costs associated with these items.

1. SAFE OPERATING PROCEDURES FOR WORKING NEAR WATER

The Contractor shall adhere to all OSHA regulations and PWC safety procedures as they pertain to water safety. The contractor’s safety plan shall include provisions for safely working near water. The Contractor shall employ a competent person that will assess potential hazards associated with working near water, such as bank destabilization. Before beginning work in a particular area, the Contractor’s competent person shall evaluate the area for hazards associated with working near water and shall keep a log of each evaluation. Upon request from the PWC Project Engineer, the Contractor shall submit the log for inspection by PWC.

2. WORKING TIMES

The Contractor shall limit their operations to Monday through Friday, between the times of 8:00 am and 5:00 pm, unless otherwise approved by Fayetteville Public Works Commission. The Contractor shall plan their daily activities in order to ensure that all work is completed by 5:00 pm. This provision will be strictly enforced by Fayetteville Public Works Commission.

3. CLEANLINESS DURING CONSTRUCTION

The Contractor shall perform a daily clean-up of all dirt, debris, scrap materials and other disposable items resulting from the Contractor’s operations, whether on-site or off-site. The Contractor shall remove all construction equipment, barricades, tools, surplus materials, etc. no longer required at the site. No open accumulation of refuse, surplus or scrap materials will

be permitted. Failure of the Contractor to maintain a clean site will be basis for Fayetteville Public Works Commission to issue a written notice of non-compliance with the Contract. Should that notice to correct not be complied with within twenty-four (24) hours, Fayetteville Public Works Commission may authorize the cleanup to be performed by others and the costs shall be deducted from monies due the Contractor. The Contractor shall legally dispose off-site all waste materials and other excess materials resulting from the Work. No separate payment shall be made for maintaining a clean project site.

4. OFFICE FACILITIES

The Contractor shall provide at his expense telecommunications via cellular phone at all times on the job site. The Project Superintendent must be onsite and accessible by telephone at all times while work is progressing. The Project Superintendent shall have access to plans, contract documents, permits, and encroachment agreements at all times whether an office facility is provided by the Contractor or not.

5. PROJECT SCHEDULE

Each week, the Contractor shall provide (via email) Fayetteville Public Works Commission with their schedule for the upcoming week. The Contractor shall immediately notify Fayetteville Public Works Commission of any deviations to their schedule. Failure to notify Fayetteville Public Works Commission of any deviations may result in payment being withheld.

The schedule shall outline the work planned for each day of the week, and shall include the following information (at a minimum):

- Date
- Time (day or night)
- Street name
- Pipe diameter
- Any applicable comments

The weekly schedule can be in spreadsheet format or done in a scheduling software, such as Microsoft Project.

6. PUBLIC SAFETY

The Contractor shall barricade all work, roads, etc. to keep the public away from the construction. The Contractor shall provide protection to all portions of the Work when the work is not in progress. The Contractor shall provide and install all measures necessary to protect the public. Damage due to the lack of proper protection shall be the Contractor's sole responsibility.

The Contractor and subcontractors shall be responsible for any damage to any Owner's property, private property, or property owned by other utilities. The Contractor shall repair all damage to as good as or better than existing conditions. The Contractor and subcontractors shall be responsible for and pay any claims.

7. JOBSITE REQUIREMENTS

In addition to requirements outlined in these Contract Documents, the following are mandatory requirements that will be strictly enforced:

- Posted speed limits shall be strictly adhered to. No speeding.
- All trenches, excavations, or other hazards in the vicinity of the work shall be well barricaded and properly lighted at night.
- Portable toilets shall be provided for workers. These facilities shall be placed discretely out of public view, kept clean, and orderly.
- The use of profane or abusive language or obscene gesturing by workmen will not be tolerated and will be just cause for immediate dismissal from the project site as directed by the Owner or its authorized representative.
- OSHA safety measures are to be maintained at all times.
- An English-speaking Contractor's representative is required for each separate work crew.
- Do not litter at any time.
- Respond to all complaints within 24 hours.
- Wear proper protective clothing (hard hats, shoes, shirts, etc.). Personnel must wear an approved safety vest at all times while working on the Owner's project.
- The trench shall be completely backfilled at the end of each workday.
- If construction is temporarily halted during the workday, the open trench shall be manned continuously.
- Damage to sod and/or grass along the street right-of-way due to (but not limited to) temporarily stockpiled material, construction travel and other construction related activities shall be replaced with sod at the Contractor's sole expense.

8. STORED MATERIALS

There will be no payment for stored materials on this project.

9. GUARANTEE

All work completed under these Contract Documents shall be guaranteed by the Contractor for a period of one (1) year from the date of final acceptance. During that period, all serious defects discovered in the work, as determined by Fayetteville Public Works Commission, shall be removed and replaced in a satisfactory manner by the Contractor at no cost to Fayetteville Public Works Commission.

10. PRECONSTRUCTION VIDEO

The Contractor shall complete a pre-construction video inspection of the project area, to document pre-existing conditions. The video shall be submitted to Fayetteville Public Works Commission on a standard portable digital media as outlined in these Contract Documents. The intent of this video is to document the roadside and/or easement conditions, easement areas, the driveways, the condition of the curb and gutter, the condition of the mailboxes, retaining walls, fences and gates, any other resident installed improvements; and the condition of the sod. The Contractor shall include any easement areas, especially those passing through yards, driveways, etc. The video must identify the house number and the street name in the audio track and visually. The Contractor may also include any pre-existing conditions they want brought to the attention of Fayetteville Public Works Commission Project Engineer by including notes and time position on the index sheet. The Contractor can also include still pictures of the areas, for additional documentation. The video and any other accompanying data shall be submitted to Fayetteville Public Works Commission Project

Engineer before any work can commence. The Contractor shall furnish copies of the video inspection in a standard digital video file format (mp4 or avi) and on a standard portable digital media (USB Flash Drive or USB Hard Disk Drive) to Fayetteville Public Works Commission

11. STAGING AREAS

The Contractor shall be required to secure staging areas for storing materials, equipment, etc. All costs, such as rent, restoration, erosion control measures, and permit fees shall be the responsibility of the Contractor. The location and operation of the staging yard shall comply with all applicable Federal, State, and local regulations.

All staging areas will be subject to inspection by Fayetteville Public Works Commission, or agents thereof, for compliance with this section without prior notice. Any deficiencies will be documented by Fayetteville Public Works Commission and written notice will be given to the Contractor in accordance with these Contract Documents. The Contractor shall rectify any deficiencies in a reasonable time frame. Failure to do so will result in breach of contract.

The Contractor will submit a Staging Area Operation Plan for each site consisting at a minimum of the following:

- The layout of each staging area clearly identifying use areas and sufficient in detail and scale to indicate the proximity of activity to adjacent residences and businesses;
- Transportation plan including routes for both ingress and egress;
- Dust control measures both on site and along transportation routes necessary to minimize the transmission of material onto streets used for ingress and egress;
- Fuel and hazardous material storage and management. Total secondary containment, shall be used for fuel and liquid hazardous materials storage and to prevent spillage.
- Hours of operation and noise mitigation measures.
- Application and Fee for the Temporary Use Permit.
- Application and Fee for Truck Route Permit.

12. COORDINATION OF WORK

The Contractor shall maintain unobstructed access to all areas for other contractors at all times. The Contractor will be required to conduct his operations in a manner that will not interfere with or damage work that is being performed by others. The Contractor shall keep other contractors informed of any necessary operations or activities that may interfere with their work. The Contractor shall plan, schedule, and coordinate his operations in a manner which will facilitate the simultaneous progress of work in adjacent areas and any additional work being performed by others on or adjacent to the site.

Any conflicts or interference that cannot be resolved through direct communication with other contractors working on the site shall immediately be brought to Fayetteville Public Works Commission attention for resolution. Fayetteville Public Works Commission Project Engineer's decisions regarding resolution of conflicts between contractors shall be final and binding on all parties. The Contractor shall not claim extra compensation for delays or hindrances caused by other contractors unless such delays or hindrances are clear violations of prior coordination agreements.

13. DAMAGE TO EXISTING UTILITIES

The Contractor shall take every precaution to guard against any damage to existing structures, pipelines, and/or equipment of the utility owner. Any damage to existing structures and/or pipelines shall be the direct responsibility of the Contractor. Damage shall be replaced and/or repaired by the Contractor as directed by the utility owner, or the value of such deducted from any monies due the Contractor under this Contract.

The utility owner shall supervise the Contractor's operation of all valves, gates, and other equipment. Except in case of emergency, the Contractor shall notify the utility owner a minimum of two (2) business days in advance of the need for operation of valves, gates, and other equipment necessary to allow the work to progress.

The Contractor shall notify the Owner a minimum of 48 hours in advance to coordinate any proposed service interruption. If an unscheduled service interruption occurs, the Contractor shall immediately notify the Owner. The Contractor shall immediately commence repairs in accordance with the utility owner's standards.

14. EROSION AND SEDIMENTATION CONTROL

The provisions of Chapter 139, North Carolina General Statutes, as amended, shall be applicable to this project. The Contractor shall progressively adjust and/or add erosion control measures to complement their type of construction to prevent erosion and the transmittal of silt. All necessary erosion control measures shall be installed prior to any work. The installed erosion control measures shall remain serviceable until the site is restored and stabilized. Upon such time (which may be after completion of the project), the Contractor shall remove all temporary measures.

All fees, penalties, fines for non-compliance and all civil actions resulting there from shall be the Contractor's responsibility and shall in no way involve Fayetteville Public Works Commission. The Contractor shall immediately notify Fayetteville Public Works Commission of any fine, penalty, or notice of non-compliance by the North Carolina Department of Environmental Quality (NCDEQ). The Contractor may be required to modify or supplement the measures at no additional cost to Fayetteville Public Works Commission.

In addition to installing and maintaining the appropriate erosion control devices, the Contractor shall maintain a neat and clean jobsite. The Contractor shall take the necessary measures to minimize dust, ensure the streets are clean and free of debris, and other measures as required. The Contractor shall maintain the proper erosion control devices to ensure against erosion. The Contractor shall ensure that the catch basin and inlet protection devices are free of dirt and debris.

Permanent and temporary erosion control measures proposed by the Contractor for staging areas, haul roads, bypass lines, etc. shall be at the Contractor's expense and shall not constitute additional compensation.

15. EQUIPMENT

The Contractor shall be equipped with equipment perfectly adaptable for the type of construction required; excavation and liner handling machines shall be of sufficient capacity to handle the work in an expeditious and safe manner. Fayetteville Public Works Commission reserves the right to deny the use of inadequate equipment or of equipment not capable of performing the work in an acceptable manner.

With respect to the foregoing, it is the intent of Fayetteville Public Works Commission to require that the Contractor be equipped to perform the work shown and specified, expeditiously and in accordance with the best modern practice.

16. SITE RESTORATION AND CLEANUP

Upon completion of an assigned area, the project location shall be immediately cleaned up and grounds restored to the conditions that existed prior to commencing work. Restoration includes, but is not limited to, seeding, mulching, placement of sod, replacement of fences, and patch paving. All restoration work shall be completed within 30 calendar days of completion of repairs. Failure to complete the restoration work in a timely manner may result in Fayetteville Public Works Commission withholding payment.

For those areas outside the project limits, the Contractor shall be responsible for installing sod in all disturbed areas, unless otherwise noted on the plans, and for the full replacement of any driveways disturbed as part of their operations. In those areas where an established stand of grass is disturbed due to the rehabilitation activities, the Contractor shall restore that area with sod. All other non-paved areas shall be seeded and mulched. Should the Contractor have questions regarding the required restoration, the Contractor shall coordinate with Fayetteville Public Works Commission.

The Contractor shall repair any damage to streets in accordance with the requirements of the appropriate agency (City of Fayetteville, Town of Hope Mills, or NCDOT). The City of Fayetteville has specific requirements for asphalt restoration, depending on the size and location of the excavation. The Contractor shall coordinate with the City of Fayetteville prior to any asphalt restoration, to ensure compliance with the City's requirements.

Surplus material, tools, and temporary structures shall be removed within 7 calendar days of completing repairs by the Contractor. All dirt, rubbish, and other debris from the operation shall be removed and legally disposed of by the Contractor, at no additional cost to Fayetteville Public Works Commission.

17. CHEMICAL USES

All chemicals used during project construction or furnished for project operation, whether herbicides, pesticides, disinfectant, polymer, reactant or of other classification, must show approval of either the Environmental Protection Agency or the USDA. Use of all such chemical and disposal of residues shall be in strict conformance with manufacturer's instructions.

18. HAZARDOUS COMMUNICATION PROGRAMS

Refer to Article 5, Paragraph 5.05 in the PWC General Conditions.

The Contractor shall be responsible to provide and maintain SDS sheets at the job site at all times. The sheets shall be located in an easily accessible and prominently located area. If the Contractor encounters any materials considered or suspected of being hazardous, the Contractor shall immediately secure the area and contact the Project Engineer for further instructions.

19. EXCAVATION

The Contractor shall be responsible for utilizing all measures necessary to comply with the applicable OSHA regulations.

20. MONTHLY PROGRESS MEETINGS

The Contractor and Fayetteville Public Works Commission Project Engineer shall mutually establish a regular time to meet on a monthly basis, for the duration of the project. The meetings shall be held at Fayetteville Public Works Commission complex at 955 Old Wilmington Road, and will generally last about an hour. The Contractor's superintendent or designated representative shall attend these meetings. The Contractor's representative shall be knowledgeable of the project, issues that need to be addressed, and be able to make binding decisions for the Contractor.

The purpose of the meeting is to discuss various project related items, including, but not limited to: safety concerns, overall project status and schedule, the Contractor's schedule for the upcoming month, issues that the Contractor and/or Fayetteville Public Works Commission Project Engineer need to address, viewing of pre and/or post lining videos, and any proposed or potential change orders.

The cost for the Contractor's representative to attend the monthly meetings shall be included in the unit prices bid.

21. BULK WATER USAGE

Fayetteville Public Works Commission will allow the Contractor to use water from its existing water system. The Contractor shall utilize proper backflow prevention devices when obtaining water from Fayetteville Public Works Commission's system. The Contractor shall contact Fayetteville Public Works Commission's Environmental System Protection Department at 910-223-4699 to determine the required backflow prevention devices, and to obtain a bulk water permit. The bulk water permit is an annual permit, and must be kept current throughout the duration of this Contract. The Contractor shall be responsible for the annual permit fee. The Contractor shall provide documentation on the amount of water used for their operations, and provide a monthly statement to Fayetteville Public Works Commission.

22. EMERGENCY RESPONSE

The Contractor shall maintain a construction crew capable of performing emergency maintenance work immediately 24 hours a day, 7 days a week to include all holidays. At a minimum, phone numbers shall be furnished for at least three (3) individuals in responsible charge (capable of making company binding decisions) to be available at all times (24 hours a day, 7 days a week to include all holidays). The emergency phone numbers and responsible individual's names will be provided to Fayetteville Public Works Commission.

In the event of an emergency, PWC's Emergency Dispatcher will contact the Contractor. The Contractor's designated emergency personnel shall be expected to respond and perform emergency maintenance work immediately, in less than two (2) hours, or the work will be performed by the appropriate utility owner and all associated costs billed to the Contractor.

Once onsite the Contractor shall notify the PWC's Emergency Dispatcher (910-678-7400) of the problem, the anticipated response time and the estimated time required to complete the repair work

The Contractor shall immediately notify Fayetteville Public Works Commission if their crews are unable to perform the emergency work or if assistance will be required from Fayetteville Public Works Commission. Any work completed by Fayetteville Public Works Commission may be billed to the Contractor.

23. SUBMITTALS

The Contractor shall not perform any portion of the Work requiring submittal and review until the respective submittal has been approved by Fayetteville Public Works Commission. Work performed prior to review and acceptance shall be at the Contractor's risk.

The Contractor shall submit the following information to Fayetteville Public Works Commission prior to commencing the first section of work. Unless the Contractor proposes to install a different type of lining system, changes the installation process or deviates in any way from the initial submission, submittals are not required prior to starting work on each task order.

The Contractor shall provide submittals, in accordance with the General Conditions, on, but not limited to, the following:

- Details (specifications, SDS, etc.) on the proposed materials to be used
- Contractor's safety plan
- Proposed project schedule
- Contractor personnel emergency contact information
- Concrete mix data
- Drawings for AST and Appurtenances
- Equipment Data Sheets for pumps, valves, probes, and sensors
- Material Data Sheets for precast concrete piers, pipe fittings, pipe, and sealants
- Operation and Maintenance Instructions for Equipment and Systems
- Sample of Contractors one year labor warranty

24. CONTRACTOR CLAIMS FOR EXTRA COST

Should the Contractor consider that as a result of any instructions given in writing by Fayetteville Public Works Commission Project Engineer, he is entitled to extra costs above that stated in the Contract; the Contractor shall give written notice to Fayetteville Public Works Commission Project Engineer. The written notice shall be sent to Fayetteville Public Works Commission Project Engineer within seven (7) calendar days after the occurrence of the event and the Contractor shall not proceed with the work affected until further advised, except in an emergency involving the safety of life or property. No claims for extra compensation will be considered unless the claim is made. Extra Work performed by the Contractor, not approved by Fayetteville Public Works Commission Project Engineer in writing shall not be considered for payment.

The Contractor shall not act on instructions received by him from persons other than Fayetteville Public Works Commission's Project Engineer. Any claims for extra compensation or extension of time on account of unauthorized instruction will not be honored. Fayetteville Public Works Commission Project Engineer will not be responsible for misunderstandings claimed by the Contractor of verbal instructions which have not been confirmed in writing, and

in no such case shall instructions be interpreted as permitting a departure from the Contract Documents unless such instruction is confirmed in writing by Fayetteville Public Works Commission Project Engineer.

25. COORDINATION WITH PROJECT ENGINEER

PWC has contracted with Haggett Engineering Associates, Inc to complete the design and provide construction observation. The Contractor shall provide a minimum of forty-eight (48) hours' notice to Haggett Engineering Associates for all necessary site inspections.

No additional payment shall be made for this coordination.

*** END OF SECTION ***

DIVISION 1
01025 – MEASUREMENT AND PAYMENT

GENERAL

This section defines the methods of measurement and payment for each of the prices listed in the Bid, which are required to complete the work. The bid price shall be full compensation for the work required under each bid item, which shall include all incidental costs relative thereto. Certain items of work are specified and/or shown as a detail in the Contract Documents. Bid prices shall include all items of work required to furnish and/or install each in accordance with the Project requirements, whether specifically stated or itemized in the Measurement and Payment description.

Each unit price for the specific line item shall include coordination with PWC personnel, all materials, labor, and incidentals associated with the specific item of work, and proper disposal of any waste items.

No payment will be made for stored materials.

AST System Conversion to UST Conversion – The lump sum unit price bid for AST System Conversion to UST Conversion shall include all work necessary to complete the work in accordance with these Contract Documents. Payment under this item shall include all costs of mobilization, bonds, insurance, and other related costs. The lump sum price shall also include, but is not limited to removal of existing gasoline/fuel tanks, concrete containment, valves, piping, pumps, disposal of the existing above ground storage tanks, installation of the new tanks as shown and specified, restoration, and all incidentals necessary to complete the specified repairs.

Contingency – This line item shall be used only upon issuance of a written work order by PWC for work not included in other items. The amount paid will be negotiated as a lump sum or unit price per each item of additional work. Any unused portion of the allowance remaining at the completion of the contract shall revert to PWC as a credit. PWC reserves the right to delete the allowance from the contract prior to award.

*** END OF SECTION ***

**DIVISION 1
01300 – SUBMITTALS**

PART 1 -- GENERAL

1.01 THE REQUIREMENT

- A. This section specifies the means of all submittals. All submittals shall be submitted to Fayetteville Public Works Commission. A general summary of the types of submittals and the number of copies required is as follows:

<u>Copies to Owner</u>	<u>Type of Submittal</u>
1	Shop drawings
1	Product samples
1	Certificates of compliance
1	Warranties

- B. All submittals shall be provided in accordance with this Section, and as outlined in Section 01000 – Supplementary Conditions. The Contractor shall refer to other Specification Sections within these Contract Documents, to ensure that all submittal requirements are adhered to. No construction shall proceed until all required submittals have been reviewed and approved by Fayetteville Public Works Commission. Any and all work performed prior to review and acceptance of the submittals by Fayetteville Public Works Commission shall be at the Contractor's sole risk. Further, failure to comply with the requirements of this Section may be considered Breach of Contract, and grounds for termination.

1.02 SUBMITTAL PROCEDURES

- A. The Contractor shall transmit each submittal with a form acceptable to Fayetteville Public Works Commission, clearly identifying the project and the Contractor, the enclosed material and other pertinent information specified in other parts of this section. The submittal shall identify variations from the Contract Documents and Product or system limitations which may be detrimental to successful performance of the completed Work.
- B. The Contractor shall revise and resubmit submittals as required, identifying all changes made since previous submittals. Resubmittals shall be noted as such.
- C. The Contractor shall distribute copies of reviewed submittals to concerned parties, with instructions to those parties to promptly report any inability to comply with provisions.

1.03 SHOP DRAWINGS

- A. General: The Contractor shall submit for review shop drawings for concrete reinforcement, structural details, materials fabricated especially for this Contract, and materials for which such Drawings are specified (as outlined in these Contract Documents) or as specifically requested by Fayetteville Public Works Commission.

- B. Shop drawings shall show the principal dimensions, weight, structural and operating features, type and/or brand of finish or shop coat, grease fittings, etc., depending on the subject of the Drawings.
- C. When so specified, or if considered by Fayetteville Public Works Commission to be acceptable, the manufacturer's specifications, catalog data, descriptive matter, illustrations, etc. may be submitted for review in place of shop drawings. In such case, the requirements shall be as specified for shop drawings, insofar as applicable.
- D. The Contractor shall be responsible for the prompt submittal of all shop drawings so that there shall be no delay to the Work due to the absence of such Drawings. Fayetteville Public Works Commission will review the shop drawings within 10 business days of receipt of such Drawings. Reviewed shop drawings will be returned to the Contractor by regular mail.
- E. Time delays caused by rejection of submittals are not cause for extra charges to Fayetteville Public Works Commission or time extensions.
- F. Requirements: All shop drawings shall be submitted to Fayetteville Public Works Commission through the Contractor. The Contractor is responsible for obtaining shop drawings from his subcontractors and returning reviewed Drawings to them. All shop drawings shall be prepared on standard size, 24-inch by 36-inch sheets, or smaller, as approved by Fayetteville Public Works Commission. All Drawings shall be clearly marked with the name of the project, Fayetteville Public Works Commission, Contractor, and pay item to which the drawing applies. Drawings shall be suitably numbered and stamped by the Contractor. Each shipment of Drawings shall be accompanied by a letter of transmittal giving a list of the drawing numbers and the names mentioned above.
- G. Product Data: Where manufacturer's publications in the form of catalogs, brochures, illustrations, or other data sheets are submitted in lieu of prepared shop drawings, such submission shall specifically indicate the particular item offered. Identification of such items and relative pertinent information shall be made with indelible ink. Submissions showing only general information will not be accepted.
- H. Product data shall include materials of construction, dimensions, performance characteristics and capacities, etc.
- I. Sample Warranties: When warranties are called for, a sample of the warranty shall be submitted with the shop drawings. The sample warranty shall be the same form that will be used for the actual warranty.
- J. Work Prior to Review: No material or equipment shall be purchased, fabricated especially for this Contract, or delivered to the project site until the required shop drawings have been submitted, processed and marked either "APPROVED" or "APPROVED AS NOTED". All materials and Work involved in the construction shall be as represented by said Drawings.
- K. The Contractor shall not proceed with any portion of the Work for which the design and details are dependent upon the design and details of equipment for which submittal review has not been completed.

- L. Contractor's Review: Only submittals which have been checked and corrected should be submitted to the Contractor by his subcontractors and vendors. Prior to submitting shop drawings to Fayetteville Public Works Commission, the Contractor shall check thoroughly all such Drawings to satisfy himself that the subject matter thereof conforms to the Drawings and Specifications in all respects. Drawings which are correct shall be marked with the date, checker's name and indications of the Contractor's approval, and then shall be submitted to Fayetteville Public Works Commission; other Drawings submitted to Fayetteville Public Works Commission will be returned to the Contractor unreviewed.
- M. Contractor's Responsibility: The review of shop drawings will be general and shall not relieve the Contractor of the responsibility for details of design, dimensions, etc., necessary for proper fitting and construction of the Work required by the Contract and for achieving the specified performance.
- N. Contractor's Modifications: For submissions containing departures from the Contract Documents, the Contractor shall include proper explanation in his letter of transmittal. Should the Contractor submit for review equipment that requires modifications to the structures, piping, layout, etc. detailed on the Drawings, he shall also submit for review details of the proposed modifications. If such equipment and modifications are accepted, the Contractor, at no additional cost to Fayetteville Public Works Commission, shall do all Work necessary to make such modifications.
- O. Substitutions: Whenever a particular brand or make of material, equipment, or other item is specified, or is indicated in these Contract Documents, it is for the purpose of establishing a standard of quality, design, and type desired and to supplement the detailed specifications. Any other brand or make which, in the opinion of Fayetteville Public Works Commission, is equivalent to that specified or indicated may be offered as a substitute subject to the following provisions:
 - a. Contractor shall submit for each proposed substitution sufficient details, complete descriptive literature, and performance data together with samples of the materials, where feasible, to enable Fayetteville Public Works Commission to determine if the proposed substitution is equal.
 - b. Contractor shall submit certified tests, where applicable, by an independent laboratory attesting that the proposed substitution is equal.
 - c. A list of installations (including contact information) where the proposed substitution is equal.
 - d. Where the acceptance of a substitution requires revision or redesign of any part of the Work, all such revision and redesign, and all new Drawings and details required therefore, shall be provided by the Contractor at his own cost and expense, and shall be subject to review of Fayetteville Public Works Commission.
 - e. In all cases Fayetteville Public Works Commission shall be the sole judge as to whether a proposed substitution is to be accepted. The Contractor shall abide by Fayetteville Public Works Commission 's decision when proposed substitute items are judged to be unacceptable and shall in such instances furnish the item, or substitute, as specified. No substitute items shall be used in the Work without written acceptance of Fayetteville Public Works Commission. Fayetteville Public Works Commission reserves the right to reject any such proposed changes or substitutions at their sole discretion, and is under no obligation to justify their decision.

- f. Acceptance of any proposed substitution shall in no way release the Contractor from any of the provisions of the Contract Documents.
- P. Complete Submittals: Each submittal shall be complete in all aspects incorporating all information and data required to evaluate the products' compliance with the Contract Documents. Partial or incomplete submissions shall be returned to the Contractor without review.
- a. Shop Drawing Distribution: The Contractor shall submit a minimum of five (5) copies of all shop drawings to Fayetteville Public Works Commission for review. Shop drawings will be reviewed, stamped and distributed with the appropriate box checked either "APPROVED", "APPROVED AS NOTED", "NOT APPROVED" or "REVISE AND RESUBMIT". Fayetteville Public Works Commission shall return three (3) copies to the Contractor and retain two (2) copies

If the Contractor requires additional copies of returned shop drawings, he shall include extra Drawings in his original submittal. Fayetteville Public Works Commission will process the Drawings and return them to the Contractor.

1.04 RECORD DRAWINGS

- A. The Contractor shall maintain a clean, undamaged set of color prints of Contract Drawings and shop drawings to be marked up for submittal as record drawings. The set shall be marked with red erasable pencil to show the actual installation where the installation varies substantially from the Work as originally shown. Where shop drawings are used, record a cross-reference at the corresponding location on the Contract Drawings. The Contractor shall give particular attention to concealed elements that would be difficult to measure and record at a later date. The record drawings shall be signed and dated by the Contractor's project manager.
- B. The Contractor shall submit one (1) set of their record drawings to Fayetteville Public Works Commission upon completion of the project. Final payment will not be made until the record drawings are received.

1.05 PRODUCT SAMPLES

- A. Contractor shall furnish for review all product samples as required by the Contract Documents or requested by Fayetteville Public Works Commission to determine compliance with the specifications.
- B. Samples shall be of sufficient size or quantity to clearly illustrate the quality, type, range of color, finish or texture and shall be properly labeled to show complete project identification, the nature of the material, trade name of manufacturer and location of the Work where the material represented by the sample will be used.
- C. Samples shall be checked by the Contractor for conformance to the Contract Documents before being submitted to Fayetteville Public Works Commission and shall bear the Contractor's stamp certifying that they have been so checked. Transportation charges on samples submitted to Fayetteville Public Works Commission shall be prepaid by the Contractor.

- D. Fayetteville Public Works Commission's review will be for compliance with the Contract Documents, and his comments will be transmitted to the Contractor within 15 business days of receipt.
- E. Acceptable samples will establish the standards by which the completed Work will be judged.

1.06 CERTIFICATES OF COMPLIANCE

- A. Copies of certificates of compliance and test reports shall be submitted for requested items to Fayetteville Public Works Commission prior to request for payment.

1.07 WARRANTIES

- A. Original warranties, called for in the Contract Documents, shall be submitted to Fayetteville Public Works Commission. When warranties are required for an item, the warranty shall be submitted prior to request for payment of that item.
- B. When warranties are requested, a sample of the warranty to be provided shall be submitted with, and considered part of, the shop drawings.
- C. The Contractor shall warrant to Fayetteville Public Works Commission that all material and labor used in the construction are covered by his warranty for a minimum of a one (1) year period upon approval and acceptance by Fayetteville Public Works Commission. The Contractor shall replace or repair defects at no cost to Fayetteville Public Works Commission during the warrantee period.

*** END OF SECTION ***

**DIVISION 1
01700 PROJECT CLOSEOUT**

FINAL CLEANUP

The Contractor shall promptly remove from the vicinity of the completed Work, all rubbish, unused materials, concrete forms, construction equipment, temporary structures and facilities, construction signs, tools, scaffolding, materials, supplies and equipment which may have been used in the performance of the work. The Contractor shall broom clean paved surfaces and rake clean other surfaces of grounds. Final acceptance of the Work by Fayetteville Public Works Commission will be withheld until the Contractor has satisfactorily complied with the foregoing requirements for final cleanup of the project site.

The Contractor shall thoroughly clean all materials, equipment and structures; all marred surfaces shall be touched up to match adjacent surfaces.

The Contractor shall remove spatter, grease, stains, fingerprints, dirt, dust, labels, tags, packing materials and other foreign items or substances from interior and exterior surfaces, equipment, signs and lettering.

The Contractor shall remove paint, clean and restore all equipment and material nameplates, labels and other identification markings.

The Contractor shall maintain cleaning until project is accepted by Fayetteville Public Works Commission.

The Contractor shall:

- A. Use only cleaning materials recommended by manufacturer of surface to be cleaned.
- B. Use each type of cleaning material on only those surfaces recommended by the cleaning material manufacturer.
- C. Use only materials which will not create hazards to health or property.

CLOSEOUT TIMETABLE

The Contractor shall establish dates for testing, acceptance periods, and on-site instructional periods (as required under this Contract). The dates shall be established a minimum of seven (7) calendar days prior to beginning any of the foregoing items, to allow Fayetteville Public Works Commission sufficient time to schedule attendance at the activities.

FINAL SUBMITTALS

Before the final acceptance of the project, the Contractor shall submit to Fayetteville Public Works Commission certain records, certifications, etc., which are specified elsewhere in these Contract Documents. Missing, incomplete or unacceptable items, as determined by Fayetteville Public Works Commission, shall constitute grounds for withholding final payment to the Contractor. A partial list of such items appears below, but it shall be the Contractor's responsibility to submit any other items which are required in these Contract Documents:

- A. Written Test results of project components.
- B. Written guarantees, where required.

- C. Certificates of inspection and acceptance by local governing agencies having jurisdiction.
- D. Releases from all parties who are entitled to claims against the subject project, property, or improvement pursuant to the provisions of law.

PUNCH LISTS

Final cleaning shall be scheduled upon completion of the project.

Fayetteville Public Works Commission will make his final inspection whenever the Contractor has notified Fayetteville Public Works Commission that the work is ready for the inspection. Any work not found acceptable and requiring cleaning, repair and/or replacement will be noted on the punch list. Work that has been inspected and accepted by Fayetteville Public Works Commission shall be maintained by the Contractor, until final acceptance of the entire project.

Whenever the Contractor has completed the items on the punch list, the Contractor shall notify Fayetteville Public Works Commission that it is ready for final inspection. This procedure will continue until the entire project is accepted by Fayetteville Public Works Commission. The final payment will not be processed until the entire project has been accepted by Fayetteville Public Works Commission and all of the requirements in these Contract Documents have been satisfied.

TOUCH-UP AND REPAIR

The Contractor shall repair any and all damage to existing facilities and surfaces. If in the opinion of Fayetteville Public Works Commission the repair work is not satisfactory, the Contractor shall make repairs until Fayetteville Public Works Commission accepts it.

MAINTENANCE AND GUARANTEE

The Contractor shall comply with all maintenance and guarantee requirements of these Contract Documents.

Replacement of earth fill, backfill, or asphalt where it has settled below the required finish elevations, shall be considered as a part of such required repair work, and any repair or resurfacing constructed by the Contractor which becomes necessary by reason of such settlement shall likewise be considered as a part of such required repair work unless the Contractor obtained a statement in writing from the affected private owner or public agency releasing Fayetteville Public Works Commission from further responsibility in connection with such repair or resurfacing.

*** END OF SECTION ***

**APPENDIX A – AST SYSTEM CONVERSION TO UST
SYSTEM DRAWINGS NOVEMBER 2, 2022**

**FAYETTEVILLE PUBLIC WORKS COMMISSION
955 OLD WILMINGTON ROAD
FAYETTEVILLE, NORTH CAROLINA 28301**

AST SYSTEM CONVERSION TO UST SYSTEM

NOVEMBER 2, 2022

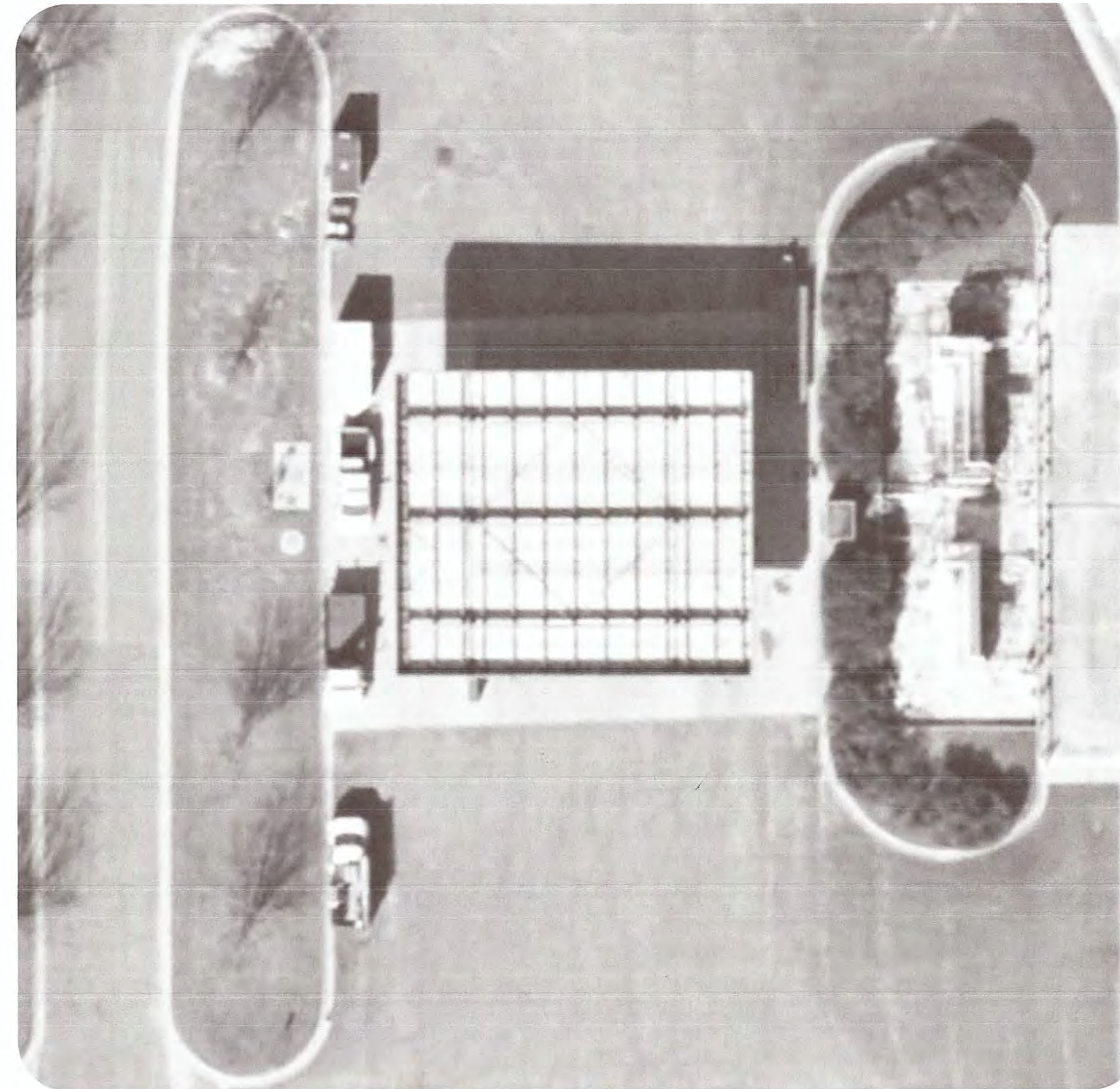

GENERAL INFORMATION

OWNER: FAYETTEVILLE PUBLIC WORKS COMMISSION
ADDRESS: P.O. BOX 1089
FAYETTEVILLE, NORTH CAROLINA 28302
TELEPHONE NO.: (910) 223-4361
FAX NO.: (910) 323-0763
CONTACT: KEVIN HOWELL, P.E.

COUNTY: CUMBERLAND COUNTY

LATITUDE: N 35° 01' 56.08" LONGITUDE: W 78° 52' 06.24"

SCHEDULE OF DRAWINGS

- C.0.1 PROJECT SPECIFICATIONS & NOTES
- C.0.2 PROJECT SPECIFICATIONS & NOTES
- C.0.3 PROJECT SPECIFICATIONS & NOTES
- C.1.1 AST CONTAINMENT - EXISTING CONDITIONS
- C.1.2 AST CONTAINMENT - DEMOLITION PLAN
- C.1.2 AST CONTAINMENT - EXCAVATION PLAN
- C.2.1 UST BASIN - PROPOSED LAYOUT
- C.2.2 UST BASIN - CONCRETE PAVEMENT
- C.3.1 PROPOSED TANK ARRANGEMENT - UNLEADED GASOLINE UST
- C.3.2 PROPOSED TANK ARRANGEMENT - DIESEL FUEL UST
- C.3.3 PROPOSED TANK ARRANGEMENT - TYPICAL UST
- C.4.1 UST VENT ASSEMBLY - INSTALLATION DETAILS
- C.5.1 TRANSITION SUMP - MODIFICATION DETAILS
- C.6.1 CONCRETE PAVEMENT DETAILS
- C.7.1 2018 PROJECT - RECORD DRAWING

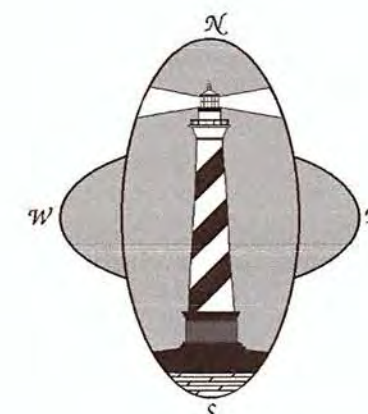

HAGGETT ENGINEERING ASSOCIATES, INC.

**5307 SOUTH COLLEGE ROAD, SUITE 2B
WILMINGTON, NORTH CAROLINA 28412
PHONE: (910) 397-0808
LICENSE NO.: C-1111
email: haggettengineeri@bellsouth.net**

**FINAL DESIGN
NOT RELEASED FOR CONSTRUCTION
WITHOUT APPROVAL FROM THE
DIVISION OF WASTE MANAGEMENT**

Existing Facilities

General

The fueling complex shall maintain the outer pump island operational during construction under this contract to the extent practical. Contractor shall provide traffic cones and safety fencing around the Work Area. The Contractor shall cooperate in every way possible to keep interruption of, and interference with, normal functions, activities of the surrounding facility to a minimum. The Contractor shall furnish competent flagmen whose sole duty shall be the directing of traffic through or around Work Area when ordered by the Owner, required by public authorities having jurisdiction, or required by law. At no time shall the Contractor prevent free access to fire hydrants, water and gas main valves, manholes or vaults or other utility facilities.

Contractor shall provide skid mounted temporary fuel supply tanks for gasoline and diesel during construction. Connection shall include electrical power and tie-in to the existing fuel dispenser system at the transition sump if deemed practical. If not practical, the temporary tanks must include dispensing equipment that will interface with the existing Fuel Master monitoring system.

Workers on the site will wear appropriate safety equipment at all times. This includes respiratory protection, eye protection and hearing protection while operating cutting equipment.

There will be no smoking or Hot Work in proximity to the AST containment, dispenser islands or excavation.

Permits

Obtain permits required for various trades.

Measurements

Verify measurements at site and assume responsibility for accuracy of measurements.

Obstructions

Remove obstructions as necessary for proper reception, performance, construction, installation, and completion of work specified herein.

Restoration

After completion of all other work, repair portions of site that have been damaged because of installation operations specified herein. This includes repair or replacement of damaged vegetation.

Records

Keep at job site a neat, complete, and accurate record of all approved deviations from contract drawings, shop drawings, and specifications, indicating work as actually installed. Record changes on prints of drawings affected. Provide to owner prior to receiving final payment.

Utility Location

CONTRACTORS SHALL BE RESPONSIBLE FOR DAMAGE TO ANY UTILITIES LOCATED WITHIN THE PROJECT BOUNDARIES, WHETHER SHOWN ON THE PLANS OR NOT, DURING THE WORK ON THE PROJECT.

CONTRACTORS SHALL BE RESPONSIBLE FOR LOCATING ALL UTILITIES LOCATED WITHIN THE BOUNDARIES IN ACCORDANCE WITH THE PROVISIONS OF ARTICLE 8A NCGS 87-115 THROUGH 87-130; UNDERGROUND UTILITY SAFETY AND DAMAGE PREVENTION ACT.

BEFORE ANY EXCAVATION, CONTRACTORS SHALL DO THE FOLLOWING:

* CALL NORTH CAROLINA 811 AT 811 IN STATE OR 1-800-632-4949 FROM ANY LOCATION TO REQUEST THE LOCATION OF PUBLIC UTILITY LINES WITHIN THE PROJECT AREA.

* CONTRACT A PRIVATE LINE LOCATOR TO LOCATE AND MARK UTILITY LINES WHICH ARE NOT OWNED BY A PUBLIC UTILITY. A LISTING OF LOCATORS MAY BE FOUND AT www.nc811.org/line-locators.html

Coordination

Cooperation

Give work the constant attention necessary to facilitate its progress. Cooperate with Engineer and PWC Representative's.

Cooperate with Environmental Contractor, if required.

Maintain at the site a competent and reliable representative authorized to receive orders and to initiate necessary actions.

Coordination

Be responsible for proper fitting and coordination of operations of various subcontractors, trades, and material men. Coordinate with PWC and Environmental Contractor for the excavation and transportation off site of petroleum impacted soils from the project site. Notify PWC if delays in the progress of the work occur or are anticipated.

Cutting and Patching

Cut, patch and refinish work as necessary to coordinate its several parts, so that it functions optimally, and as indicated in, or reasonably implied by, plans and specifications.

Submittals

General

Submittals hereinafter required shall be made to Engineer as follows, unless otherwise specified:

- Written submittals: Typed, PDF;
- Drawings for AST and Appurtenances: PDF;
- Equipment Data Sheets for pumps, valves, probes and sensors: PDF.
- Material Data Sheets for precast concrete piers, pipe fittings, pipe and sealants: PDF.
- Concrete Mix Design: PDF.
- Operation and Maintenance Instructions for Equipment and Systems: PDF.

Progress Schedule

The Contractor shall provide a written schedule prior to starting work and shall provide updates at the end of each work week.

Progress schedule shall show proposed dates of start and completion of each subdivision of work.

Cost Schedule

Cost schedule shall show detailed breakdown of costs including unit pricing for each item of work. Sum of all items shall equal contract price.

Restoration and Repair

The Contractor shall make satisfactory and acceptable arrangements with the Owner and/or Engineer to repair and restore all structures, property, utilities, and facilities disturbed, disconnected, or damaged as a result of this Work.

Damaged vegetation shall be repaired or replaced.

It shall be the contractor's responsibility to insure that the damaged areas are re-vegetated in a manner satisfactory to the Owner.

The contractor shall protect sub-surface utilities

Selective Demolition

Work Included

A. Demolition required for this work includes, but is not necessarily limited to:

- Saw-cutting and removal of existing concrete as required to complete the removal of the existing concrete containment, concrete piers and trimming of existing curb as needed.
- Removal of the two (2) Aboveground Storage Tank (AST) systems including the tanks, off-load pumps, submerged turbine pumps (STP), valves, piping, probes, sensors, platforms and ladders. Contractor shall take possession of the tanks, off-load pumps, platforms, ladders, submerged turbine pumps and appurtenances upon removal from their currently installed locations. Contractor shall complete the removal of fuel and/or water from the tanks, cleaning and preparation for transport.
- Proper disposal of removed materials at a licensed facility. Contractor shall provide a written certificate of disposal or recycle for tanks removed from the Owners property.
- Removal and replacement of electrical conduits and connections as required.

Related Work Described Elsewhere

- Earthwork - Section 02200.
- Cast In Place Concrete - Section 03300.

Definitions

The term "demolition" as used herein includes the removal of designated existing objects, plus such other work as is described in the this section of the specifications.

Quality Assurance

A. In addition to complying with all pertinent codes and regulations, comply with the requirements of those insurance carriers providing coverage for this work.

Materials

- Temporary Barricades
 - Unless otherwise specifically approved by Engineer, use only new and solid lumber of utility grade or better to construct temporary barricades.
- Explosives
 - Do Not use explosives for the performance of this work.
- Other Materials
 - All other materials not specifically described, but required for proper completion of this section, as selected by Contractor subject to approval of Engineer.

Preparation

- Notification
 - Notify Engineer and Owner at least 48-hours prior to commencing the work of this section.
- Site Inspection
 - Prior to all work of this section, carefully inspect the entire work area and all objects designated to be removed and to be preserved.
 - Record information needed to re-install existing components, conduits and supports.
- Clarification
 - The drawings do not purport to show all objects existing on the site.
 - Before commencing the work of this section, verify with Owner and/or Engineer objects to be removed and objects to be preserved.
- Scheduling
 - Schedule all work in a careful manner with all necessary consideration for neighbors, the public, and PWC personnel.
 - Avoid to the extent practical interference with the use of, and passage to and from, adjacent buildings or facilities.
- Disconnection of Utilities
 - Before starting site operations disconnect or arrange for the disconnection of all utility services designated designated to be removed or which may, due to their proximity to the work, create a safety hazard. Perform all such work in accordance with the requirements of the utility company or agency involved.
- Protection of Utilities
 - Preserve in operating condition all active utilities traversing the site and designated to remain. Contact NC811 a minimum of 3 business days prior to construction.

Construction of Banicades

- Layout
 - Make barricades a minimum of three feet high consisting of 2-inch by 4-inch or larger post at not more than 6-feet on centers, joined at the top by 1-inch by 6-inch or larger boards firmly attached to the post. Barricades shall be white with approved reflectorized stripes. Provide warning flashers on areas to be barricaded overnight.
- Protection
 - Do not permit stockpiling of materials or debris within the barricaded area except as specifically approved by Engineer.

Removal of Concrete and/or Asphaltic Concrete

- Lay-out areas to be removed; establish straight cut lines.
- Remove asphaltic concrete surfaces and/or reinforced concrete surfaces, and substrates to each.
- Saw cut to establish lines resulting in vertical planes.

Removed Materials

A. All removed materials under this section shall become the property of Contractor for Contractor's off-site disposal.

Job Conditions

- Dust Control:
 - Use all means necessary to prevent the spread of dust during performance of the work of this section; thoroughly moisten surfaces as required to prevent dust being a nuisance to the public, neighbors, and concurrent performance of other work on the site. Dry cutting of concrete and masonry shall not be allowed.

Protection

A. Roads and Walks - Keep roads and walks free of dirt and debris at all times.

B. Utilities:

- Protect existing utility lines that are indicated to remain from damage. Notify OWNER immediately of damage to or an encounter with an unknown existing utility line. The CONTRACTOR shall be responsible for the repairs of damage to existing utility lines that are indicated on the plans or made known to the CONTRACTOR prior to the start of the project. CONTRACTOR shall contract for the location of utilities within the proposed work area. Failure of the CONTRACTOR to contract for the location of utilities shall not relieve the CONTRACTOR of the responsibility to repair damage to existing utility lines.

Disposal of Materials

A. Non-saleable Materials

- Concrete, concrete block, brick, asphalt, pipe, wood, and other refuse from the demolition, shall be disposed of by the CONTRACTOR off site. The CONTRACTOR shall be responsible for compliance with all Federal, State and Local regulations.

Earthwork

Work Included

- The extent of excavation, filling and grading is shown on the approved plans. Excavation of soils will be limited to that required to remove AST piers and to install the UST System tanks, pipes and conduits. Soils located beneath the AST Containment are not known to contain petroleum hydrocarbon constituents.
- The Contractor shall notify the Owner and Engineer immediately if soils containing petroleum hydrocarbon constituents are encountered. Removal and disposal of soils containing petroleum hydrocarbon constituents shall be completed by an Environmental Contractor with the appropriate HAZWOPER training. Removal and disposal of petroleum impacted soils shall be completed at PWC's expense.
- Porous fill under the concrete containment is included as part of the work of this section.
- Compaction of porous fill is included as part of the work of this section.

Related Work Described Elsewhere

- Demolition.
- Cast-in-Place Concrete.

Reference Standards

- Stone backfill material - ASTM C-33 paragraph 7.1 for soundness.
- Soil backfill material - ASTM D-2487, soil classification groups GW, GP, GM, SM, SW and SP.

Site Conditions

- Site Information
 - Soil borings have not been advanced in the area proximal to the AST Containment. Therefore, data concerning the existing sub-grade soils is not available.
- Existing Utilities
 - Verify locations of all existing underground utilities in the area of work.
 - Protect from damage during all construction operations.
 - Hand excavate where necessary, to locate buried conduits, wires, pipes, tanks or similar items.
- The use of explosives will not be permitted.

Protection

- Protect structures, utilities, sidewalks, pavements and other site items to remain.
- Barricade open excavations and provide warning lights. The contractor shall provide, install and maintain OSHA approved barrier fencing around the excavation. Post shall be installed not more than 8-feet apart.
- Take precautions and provide necessary bracing and shoring to guard against movement or settlement of existing improvements or new construction. Contractor is entirely responsible for strength and adequacy of bracing and shoring, and for safety and support of construction from damage or injury caused by the lack thereof or by movement or settlement.

Materials

A. Porous fill under concrete structures and concrete slabs on grade shall be NCDOT Class II, Type 1 Select Material as defined in Table 1016-1. Place the Select Material in compacted thickness as shown on the plans or as approved by the Engineer.

Sieve	Percent Passing
3/8"	100
No. 4	80 - 100
No. 10	65 - 95
No. 40	25 - 55
No. 200	0 - 20
LL	≤ 30
PI	≤ 6

Excavation

- Excavation consists of removal and disposal of material encountered when establishing required grade elevations. Excess materials may Not be disposed of on-site.
- Excavation in this contract is "unclassified", which shall mean excavation and removal of materials of every description existing in spaces to be excavated.
- Unauthorized Excavation
 - Unauthorized excavation consists of removal of materials beyond indicated subgrade elevations or dimension without specific direction of the Engineer. Unauthorized excavation shall be at the Contractor's sole expense.
 - Backfill and compact unauthorized excavation as specified for authorized excavations of same classification, unless otherwise directed by the Engineer.
- Stability of Excavations
 - Slope sides of excavations to comply with local codes, ordinances, and OSHA regulations. Shore and brace where sloping is not possible either because of space restrictions for stability of material excavated. Maintain sides and slopes of excavations in a safe condition until completion of backfilling.
- Shoring and Bracing
 - Provide materials for shoring and bracing, such as sheet piling, uprights, stringers and cross-braces, in good serviceable condition.
 - Provide minimum requirements for trench shoring and bracing to comply with local codes and authorities having jurisdiction.
 - Maintain shoring and bracing in excavations regardless of time period excavations will be open.
 - Carry down shoring and bracing as excavation progresses.

FAYETTEVILLE PUBLIC WORKS COMMISSION
955 OLD WILMINGTON ROAD
FAYETTEVILLE, NORTH CAROLINA 28351

NO.	REVISION	DATE

HAGGETT ENGINEERING ASSOCIATES, INC.
5307 SOUTH COLLEGE ROAD, SUITE 2B
WILMINGTON, NORTH CAROLINA 28412
PHONE: (910) 397-0808
LICENSE NO.: C-1111

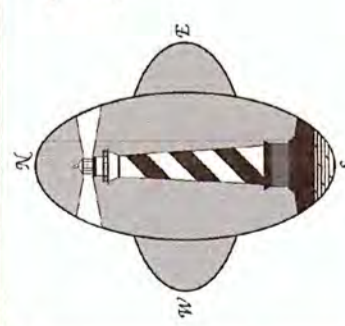

DRAWING:
C.0.1

PROJECT SPECIFICATIONS & NOTES

- F. Dewatering
1. Prevent surface water and subsurface or ground water from flowing into excavations and from flooding project site and surrounding area.
 2. Provide and maintain pumps, sumps, suction and discharge lines, and other dewatering system components necessary to convey water away from excavations.
 3. Provide means to control sediment and silt from being discharged onto adjacent properties or nearby waterways.
- G. Material Storage
1. Stockpile satisfactory excavated materials where directed, until required for backfill or fill.
 2. Place, grade, and shape stockpiles for proper drainage.
 3. Locate and retain soil materials away from edge of excavations.
 4. Dispose of excess soil material and waste materials as specified hereinafter.
 5. Provide erosion control as required to meet Codes.
 6. Protect stockpiled excavation materials from causing muddy run-offs or dirt on adjacent paving and structure.
- H. Excavation for Structures
1. Conform to elevations and dimensions shown within a tolerance of plus or minus 0.08 of one foot (1-inch), and extending a sufficient distance from footings and foundations to permit placing and removal of concrete formwork, installation of services, other construction required, and for inspection.
- I. Cold Weather Protection
1. Protect excavation bottoms against freezing when atmospheric temperature is less than 35°F.

Filling, Backfilling and Rough Grading

- A. Do no backfilling around any parts of the structures (tanks, piping, reinforcements, waterstops) until such parts have been inspected and the backfilling authorized by the Engineer or Owners representative.
- B. Install filling and backfilling in 6-inch layers, dampened, and compacted at optimum moisture content to a dry density of not less than 100% of the maximum dry density for structures and not less than 95% of the maximum dry density for piping and conduit trenches in paved areas as determined by ASTM D-1557, Method C.
- C. Owner shall provide compaction testing in accordance with the following:
1. Four tests for each 6-inch layer of soil placed that is located within 5-feet of the finished sub-grade or grade up to 3,000 square feet of surface.
 2. Two test for each 6-inch layer of sand or ABC placed per 2,500 square feet of surface that is placed within 5-feet of the finished grade or sub-grade.
 3. Compaction testing for NCDOT 57 and NCDOT 78M stone is not required.
- B. Clean excavations and areas to be filled of all topsoil, vegetable matter, refuse and debris before placing any fill, backfill or bedding.
- C. Perform filling and backfilling carefully so as not to damage other work or affect that stability of any construction. Do backfilling only when the structures are fully capable of withstanding the resulting pressure.
- D. Do not fill or backfill over frozen subgrade or use any frozen material in fill or backfill.

Compaction

- A. Perform compaction of soil materials for backfills and fills using suitable soil compaction equipment for materials to be compacted and work area locations.
- B. Control soil compaction during construction for compliance with percentage of maximum density specified for each area classification.
- C. Percentage of Maximum Density Requirements:
1. Provide not less than the following percentage of maximum density of soil material compacted at optimum moisture content, for the actual density of each layer of soil material-in-place. (Compaction percentages refer to the maximum modified proctor as described in ASTM D-1557-07).
 - a. Compact top 30-inches of sub-grade and each layer of backfill for fill material at 100% maximum density under structures.
 - b. Compact top 18-inches of sub-grade and each layer of backfill or fill material at 100% maximum density under asphalt or concrete paving or traffic bearing areas.
 - c. Compact each layer of backfill material at 90% maximum density for trenches in unpaved or non-traffic bearing areas.

Grading

- A. General
1. Uniformly grade areas within limits of grading under this Section, including adjacent transition areas.
 2. Smooth finished surface within specified tolerances, compact with uniform levels of slopes between points where elevations are shown; or between such points and existing grades.
- B. Compaction
1. After grading, compact sub-grade surfaces to the depth and percentage of maximum density as required to avoid erosion or subsidence.

Maintenance

- A. Protection of Graded Areas
1. Protect newly graded areas from traffic and erosion, and keep free of trash and debris.
- B. Repair and re-establish grades in settled, eroded, and rutted areas to specified tolerances.

Disposal of Excess and Waste Materials

- A. Remove waste materials, trash and debris from the Owner's property and legally dispose of it.
- B. Remove excavated soils from the site unless otherwise directed by the Owner and approved by the Engineer.
- C. Petroleum hydrocarbon impacted soils, if present, shall be transported from the site under a non-hazardous waste manifest and shall be disposed of at a facility approved by the North Carolina Department of Environment Quality. Contractor shall provide to the owner copies of each properly completed manifest including weight tickets from a North Carolina certified scale.

Cast-in-Place Concrete

Reference Standards

- A. ACI: American Concrete Institute, Manual of Practice.
- B. CRSI: Concrete Reinforcing Steel Institute, Manual of Standard Practice.
- C. ASTM: American Society of Testing and Materials.

Related Work Specified Elsewhere

- A. Earthwork

Submittals

- A. A delivery ticket indicating the truck number, date, and time that mixing was started shall be submitted with each batch at time of delivery. The contractor shall complete the ticket by indicating the arrival time, depositing time and concrete placement location. The delivery ticket shall also contain the project name and number, date; mix type including strength, aggregate type, amount of water, and design slump; and batch quantities. Failure to deliver such completed ticket shall be cause for rejection, removal, and replacement by the Contractor at any time or stage of the work.
- B. The Owner shall retain and pay for the services of an independent concrete testing service to sample and test the concrete during the course of the work. The testing service shall meet the requirements of ASTM E-329. The contractor shall submit the results of the following test for each load of concrete:
1. Slump test in accordance with ASTM C-143.
 2. Air Content in accordance with ASTM C-173.
 3. Compression Test for two specimens in accordance with ASTM C-31 and C-39. One specimen tested at 7 days and one specimen tested at 28 days.

Materials

- A. Form materials for exposed finish concrete: sawn lumber, plywood, metal or other acceptable panel-type material for producing continuous smooth surfaces. Use largest practicable sizes to minimize number of joints and to conform with joint system shown on drawings. Use sufficient thickness to withstand pressure of wet concrete without deflection. Comply with applicable recommendation of ACI 347 - Recommended Practice for Concrete Formwork.
- B. Steel Reinforcement:
1. Reinforcing bars: ASTM A-615, grade 60, deformed
 2. Stirrups and ties: ASTM A-615, grade 40
 3. Welded wire fabric reinforcement: ASTM A-185 welded steel wire fabric
 4. Accessories: conform with CRSI manual. Accessories exposed in finished surface shall be galvanized.
- C. Concrete Materials:
1. Portland cement: ASTM C-150, Type I
 2. Aggregates: ASTM C-33 and the following:
 - a. Fine aggregate: clean, sharp, natural sand, free from loam, clay, lumps or other deleterious substances.
 - b. Coarse aggregate: clean, uncoated, processed, locally available and containing no clay, mud, loam or foreign matter.
 - c. Store fine and coarse aggregate separately.
 3. Water: Clean, free from oil, acid, alkali, injurious amounts of vegetable matter and other impurities; potable.
 4. Admixtures: ASTM C-494 for water reducing or ASTM C-260 for air-entraining. Mix in accordance with manufacturer's directions.
 5. Synthetic Fibers: Fibermesh MD fibrillated polypropylene fibers as manufactured by Synthetic Industries, Chattanooga, TN 37416.

Mixes

- A. Mix Design: In accordance with ACI 301. Provided written test reports when requested by Owner or Engineer.
1. Compressive Strength: 4000 psi, 28 day compressive strength
 2. Slump: 2 to 3 inches
 3. Water-cement Ratio: not to exceed 0.45.
 4. Air Content: 4 to 6 percent
 5. Fly Ash Content: not to exceed 20 percent or cement content by weight.
- B. Concrete Mixing: Comply with requirements of ASTM C 94. When ambient temperature is between 85 F and 90 F reduce delivery and mixing time from 1-1/2 hours to 75 minutes, and when ambient temperature exceeds 90 F reduce mixing and delivery time to 60 minutes.

Fabrications

Shop-fabricated reinforcing: ACI 318, Section 5.

Reinforcement and Embedded Items

- A. Preparation: Clean reinforcement of loose rust, mill scale and other materials which reduce or destroy bond with concrete. Use only new stock.
- B. Placement: Concrete Reinforcing Steel Institute's recommended practice for "Placing Reinforcing Bars". Avoid cutting or puncturing the polyethylene vapor barrier when present.
- C. Embedded Items: Set anchorage devices and other items into the work which are required for work specified elsewhere. Use setting drawings and instructions provided by suppliers of items to be attached thereto. Furnish ties and supports necessary to keep embedded items in place during concrete placement.

Joints

- A. Construction Joints: Locate and install construction joints as indicated, if not indicated, locate as not to impair the strength and appearance of the structure. Place construction joints perpendicular to main reinforcement. Continue reinforcement across construction joints unless otherwise noted.
- B. Isolation Joints (slabs-on-grade): Construct isolation joints at points of contact between slabs-on-grade and vertical surfaces such as walls, grade beams, pedestals, or existing slabs on grade (unless tie in is specified).
- C. Control Joints (slabs-on-grade): Construct control joints in slabs-on-grade to form panels as indicated on the plans. Use saw cuts 1/8-inch wide by 1/4 slab depth or inserts 1/4-inch wide by 1/4 depth of slab unless otherwise indicated.

Concrete Placement

- A. Notify Engineer forty-eight (48) hours before placing concrete.
- B. Do not start concrete placing until items to be embedded have been secured, cleaned, inspected and approved in place by the Engineer.
- C. Do not start placing concrete until forms, completely assembled and erected, have been approved by the Engineer.

- D. Place concrete in compliance with ACI 304 and as herein specified. Deposit continuously or in layers of such thickness that no concrete will be placed on hardened concrete in a manner to cause seams or planes of weakness. If a section cannot be placed continuously, provide construction joints. Deposit concrete near to or in its final location to avoid segregation caused by rehandling or flowing. Deposit floor slab concrete between screeds at finished level. Set screeds to insure maximum slab thickness, allowing 1/8" shrinkage. Scream with straight-edge and leave no hollows or pockets in surface. Obtain a tolerance after curing of no more than 1/8" in 10'.
- E. Do not place concrete when the elements of nature (heat, cold, wind, rain, etc.) will prevent proper placement, consolidation, finishing and curing.

Finishing of Slabs

- A. Floors which have an exposed integral cement finish: Tamp concrete to force aggregate away from surface and screed. Float surface and trowel lightly. When concrete has set sufficiently to ring under trowel, do a second troweling to produce a smooth, dense surface free from trowel marks, sweeps, air bubbles and other troweling imperfections. Do not add water.
- B. Exterior entrances and walks: Finish as in "A", except omit second troweling. Brush with a light broom at right angles to directions of pedestrian travel. Score to patterns indicated with small radius edging tool to a minimum 1/2" depth.

Curing

- A. Conform with ACI 605. Protect concrete against rapid drying. Keep moist for at least seven days after placing. Concrete from which forms are removed within seven days, as well as all cement finishes, shall be sprayed as frequently as drying conditions may require.
- B. Start curing immediately following last finishing operation. Continue curing for not less than 7 days. Keep concrete moist for not less than 7 days.
- C. Permit no traffic that could damage the surface over compound during curing period.
- D. If necessary, use curing compound compatible with any subsequent finish.
- E. Follow manufacturer's recommendations for curing compounds.

Protection

- A. No kneeling, working, or walking on finished surface shall be allowed for 16 hours after concrete is deposited.
- B. Comply with applicable recommendations of ACI 305 - Recommended Practice for Hot Weather Concreting and/or ACI 306 - Recommended Practice for Cold Weather Concreting.

Underground Storage Tank System

Preparation

- A. A precast concrete deadman anchoring system is required to counteract the buoyancy of the tanks due to the presence of groundwater within the UST basin. Refer to details provided by the manufacturer.
- B. Installation of sheet piles or a similar protective system is required to install the UST System. Dewatering of the excavation shall be completed and maintained until the UST System is properly anchored.

Safety

- A. It is the Contractor's responsibility that all excavation work and site conditions are within the regulations as established by OSHA. Any property damage or bodily injury (including death) that arises from use of the trench safety systems, from the Contractor's negligence in performance of the contract work, shall remain the sole responsibility and liability of the Contractor.
- B. Flammable or combustible vapors may be encountered by the Contractor or his agents while present in the work area. The Contractor shall be solely responsible for determining/removing the concentration of vapors in the excavation or the work area prior to construction activities.
- C. As this explosion hazard is foreseeable, the Contractor shall be responsible for venting the excavation and providing a safe working environment with respect to explosion hazards and air quality. Therefore, precautions must be taken by the Contractor to:
1. Eliminate all potential sources of ignition from the area (e.g., smoking materials and explosion-proof electrical and internal combustion equipment).
 2. Eliminate vapors.
 3. Prevent the accumulation of vapors at ground level.
 4. Protect persons in the area of affected soil from the hazards related to the aforementioned vapors. Refer to API Publication 2015 and Recommended Practice 2003 for general precautionary measures to follow during the vapor-freeing procedure.
 5. A Combustible Gas Indicator (CGI) shall be used to check for hazardous vapor concentrations. All open flame and spark-producing equipment within the vapor hazard area should be shut down for the duration of the project. Electrical equipment (e.g., pumps and portable hand tools) used in the area must be explosion-proof in accordance with NFPA 70B Class I, Group D or otherwise approved for use in potentially explosive atmospheres.

Tank Handling

- A. Do not handle or install tank without having knowledge and experience in procedures involved with proper and safe installation of an aboveground tank used for storage of stable, flammable and combustible liquids. To avoid tank damage, use skilled, professional installers.
- B. Equipment for handling the tank shall be of adequate size to lift and position the tank. DO NOT DROP OR DRAG THE TANK.
- C. Tanks shall be carefully handled. Use cables or chains of adequate length (with spreader bars, if necessary) and size. Attach to the tank using the lifting lugs provided. Care should be taken that the angle between the two cables, at the lift point, shall be no greater than 60 degrees.
- D. DO NOT HANDLE OR MOVE THE TANK UNLESS IT IS EMPTY.

Tank Installation

- A. Install tank as shown on the contract drawings and in accordance with the manufacturer's installation drawings and written instructions.
- B. Level tank as necessary using approved fill material. The tank shall be installed level +/- one inch end to end as measured on the top of the shell.

Tank Tightness Testing

- A. General Requirements
1. An on-site air test of the tank shall be required by to ensure no damage has occurred in shipping and handling. All testing shall be performed as described below.
 2. The Contractor shall notify the Engineer and Owner, in writing, a minimum of seven (7) calendar days prior to scheduling the installation testing.

FAYETTEVILLE PUBLIC WORKS COMMISSION
 955 OLD WILMINGTON ROAD
 FAYETTEVILLE, NORTH CAROLINA 28351

NO.	REVISION	DATE

HAGGETT ENGINEERING ASSOCIATES, INC.
 5307 SOUTH COLLEGE ROAD, SUITE 2B
 WILMINGTON, NORTH CAROLINA 28412
 PHONE: (910) 397-0808
 LICENSE NO.: C-1111

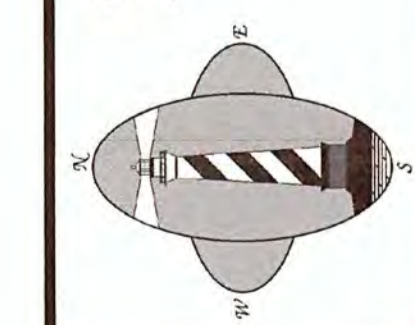

PROJECT NO.: 20-1019
 CHECKED BY: DOUG HAGGETT
 DATE: 18OCT2022
 SCALE: AS SHOWN

DRAWING:
C.0.2

PROJECT SPECIFICATIONS & NOTES

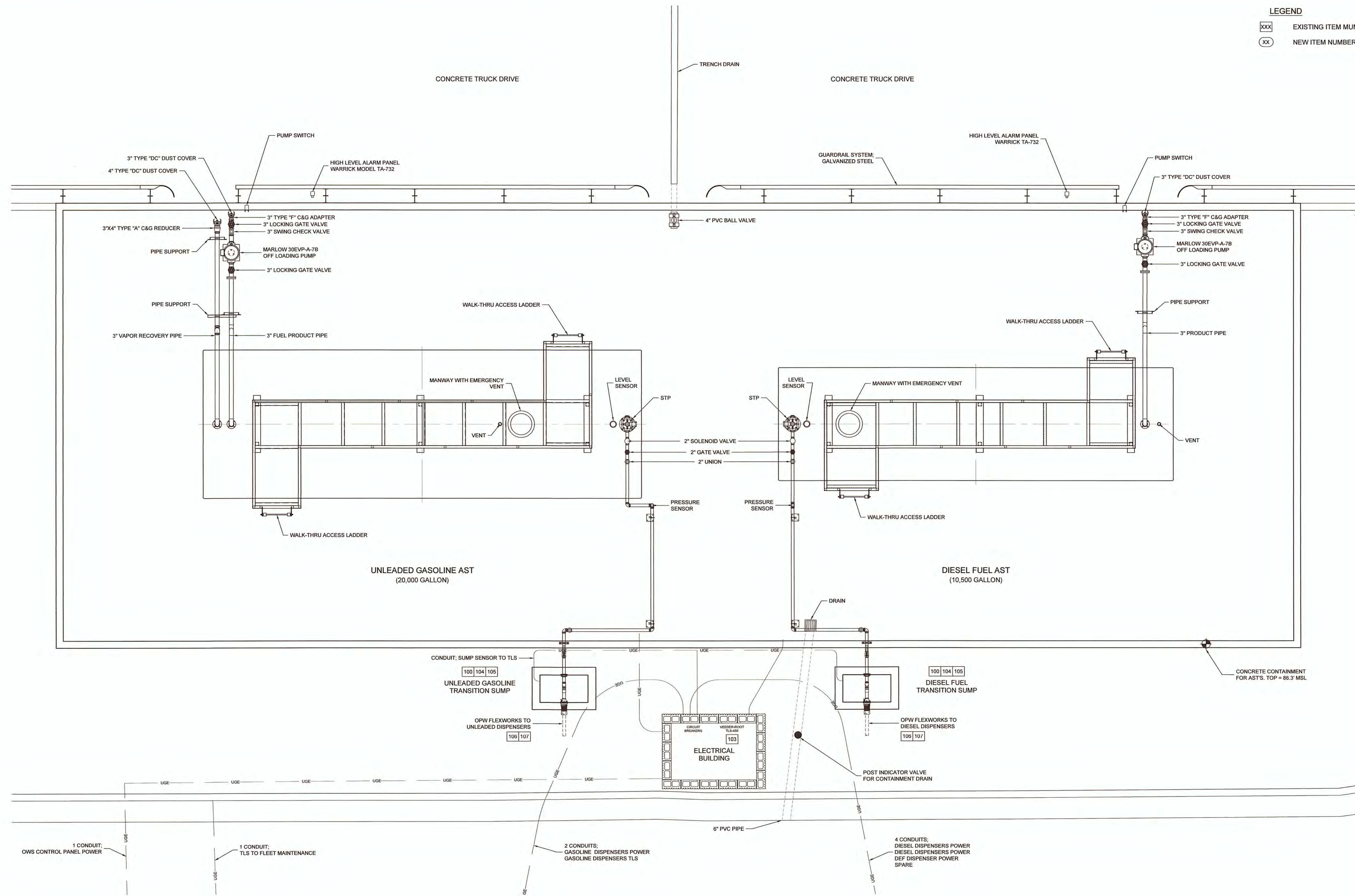

LEGEND

XXX	EXISTING ITEM NUMBER
XX	NEW ITEM NUMBER

FAYETTEVILLE PUBLIC WORKS COMMISSION
 955 OLD WILMINGTON ROAD
 FAYETTEVILLE, NORTH CAROLINA 28351
 AST CONTAINMENT - EXISTING CONDITIONS

NO.	REVISION	DATE
1	added item numbers	02/20/22

HAGGETT ENGINEERING ASSOCIATES, INC.
 5307 SOUTH COLLEGE ROAD, SUITE 2B
 WILMINGTON, NORTH CAROLINA 28412
 PHONE: (910) 397-0808
 LICENSE NO.: C-1111

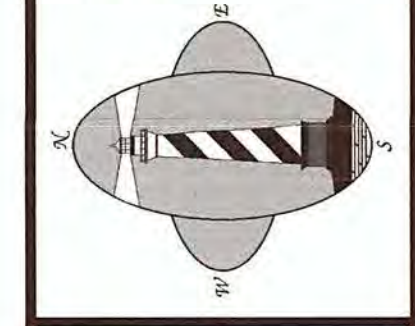

DRAWING:
C.1.1

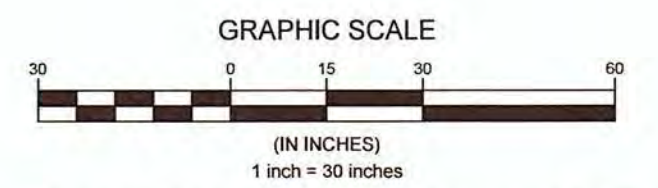

AST CONTAINMENT - EXISTING CONDITIONS

© 2022 HAGGETT ENGINEERING ASSOCIATES, INC.

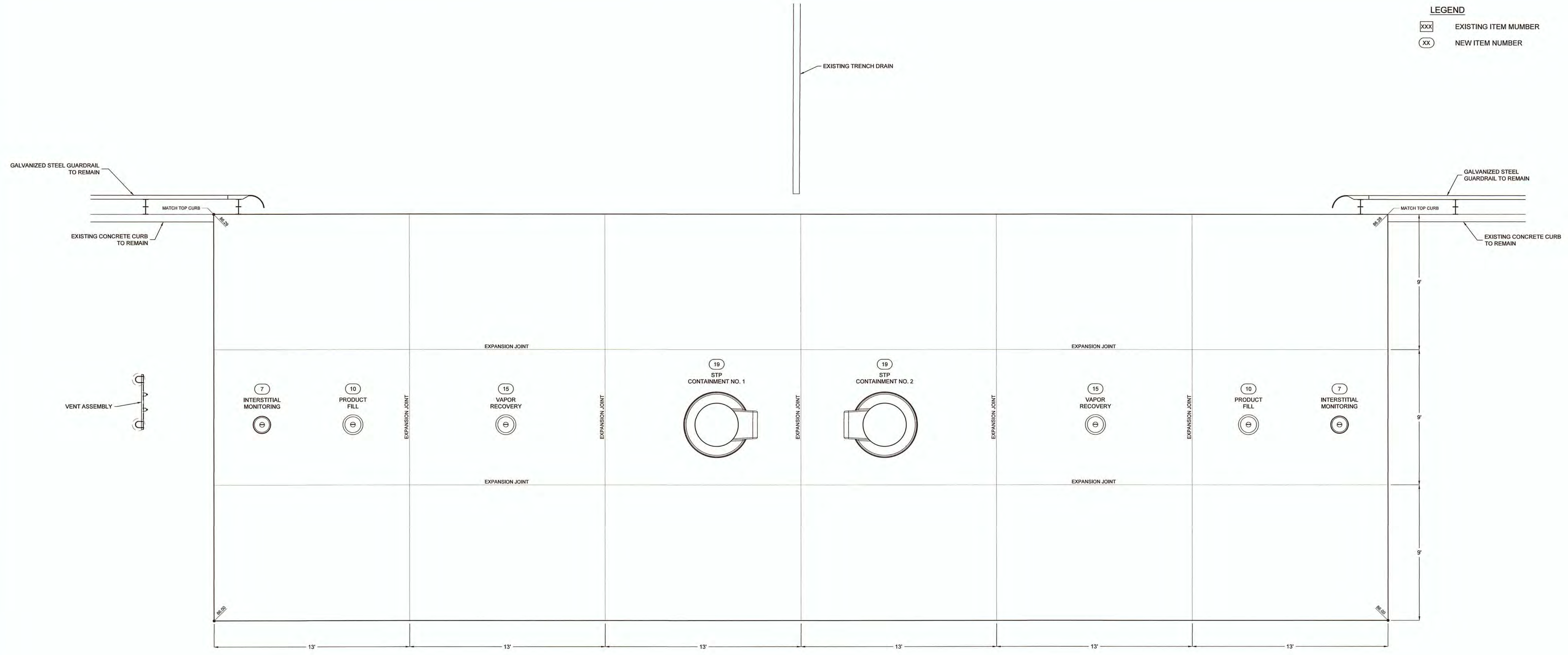

LEGEND

XXX	EXISTING ITEM NUMBER
XX	NEW ITEM NUMBER

FAYETTEVILLE PUBLIC WORKS COMMISSION
 955 OLD WILMINGTON ROAD
 FAYETTEVILLE, NORTH CAROLINA 28351

NO.	REVISION	DATE
1	added item numbers	02/01/22

HAGGETT ENGINEERING ASSOCIATES, INC.
 5307 SOUTH COLLEGE ROAD, SUITE 2B
 WILMINGTON, NORTH CAROLINA 28412
 PHONE: (910) 397-0808
 LICENSE NO.: C-1111

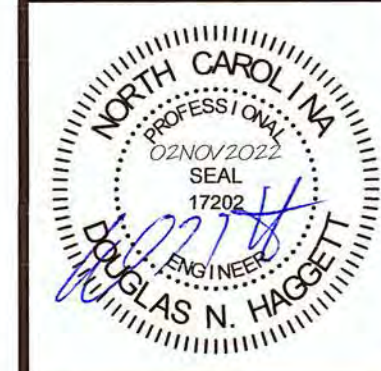
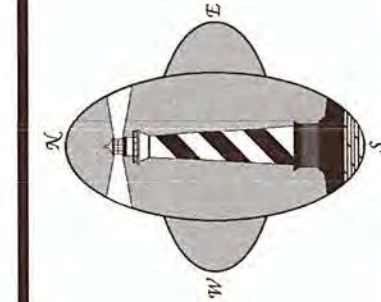

DRAWING:
C.2.2

CONTRACTOR SHALL PROTECT AND PRESERVE CONDUITS AND PIPE SYSTEMS INTENDED TO REMAIN IN SERVICE.

WARNING
 You are working in a dangerous environment of gasoline, gasoline vapor, and electricity. Failure to install this equipment in accordance with NFPA 30A and NFPA 70 can result in severe injury or death. Read, understand, and follow NFPA 30A and NFPA 70.

- Before installing the equipment, read, understand, and follow:
- The NEC (NFPA 70)
 - The Automotive and Marine Service Code (NFPA 30A)
 - Any national, state, and local codes that may apply

CAUTION
 Failure to install the equipment as per the NFPA 30A and NFPA 70 may adversely affect the safe use and operation of the system.

FINAL DESIGN
 NOT RELEASED FOR CONSTRUCTION
 WITHOUT APPROVAL FROM THE
 DIVISION OF WASTE MANAGEMENT

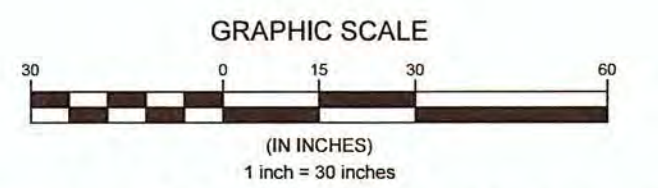

UST BASIN - CONCRETE PAVEMENT



3250 US Highway 70 Business West
Smithfield, NC 27577-6954
(919) 934-2786



Highland Tank

2700 Patterson Street
Greensboro, NC 27407
(336) 218-0801
Christopher Moore
cmoore@highlandtank.com

LEGEND

- XXX EXISTING ITEM NUMBER
- XX NEW ITEM NUMBER

INTERSTITIAL MONITOR:

- 7 OPW PN 104A-1200WT MANHOLE
- 8 VEEDER-ROOT PN 794380-333 SENSOR
- 9 VEEDER-ROOT PN 312020-928 2" SENSOR RISER CAP KIT

PRODUCT FILL:

- 10 OPW PN 1C-3132D DOUBLE WALL SPILL CONTAINER
- 11A OPW PN 71SOM-412C OVERFILL PREVENTION VALVE
- 12 OPW PN 633T-8075 FILL ADAPTER
- 13 OPW PN 633LC-1000 LOCK CLAMP (2)
- 14 OPW PN 634TT-785-EVR FILL CAP

VAPOR RECOVERY:

- 15 OPW PN 1C-3101D SINGLE WALL SPILL CONTAINER
- 16 OPW PN 233-4420 EXTRACTOR FITTING
- 17 OPW PN 61VSA-1020-EVR VAPOR RECOVERY ADAPTER
- 18 OPW PN 1711T-7085-EVR VAPOR RECOVERY CAP

STP CONTAINMENT:

- 4 OPW PN DPC-2200A DOUBLE WALL COUPLING, STAINLESS STEEL
- 19 OPW PN FCSM-1-4233CR TANK SUMP
- 20 OPW PN 42MAT-PL12 MANHOLE
- 21A VEEDER-ROOT PN 846396-110 FUEL PROBE WITH 846400-100 GASOLINE FLOAT KIT
- 22 VEEDER-ROOT PN AGP150S1 R/J SUBMERGED TURBINE PUMP
- 23 OPW PN FC20-MM12 FLEXIBLE CONNECTOR, STAINLESS STEEL
- 24 OPW FULL PN 21BV-0200 FULL PORT BALL VALVE
- 25 VEEDER-ROOT PN 859080-001 DIGITAL PRESSURE LINE LEAK DETECTOR
- 26 VEEDER-ROOT PN 794380-208 LIQUID LEVEL SENSOR

CONCRETE SURFACE
(no motor vehicles)

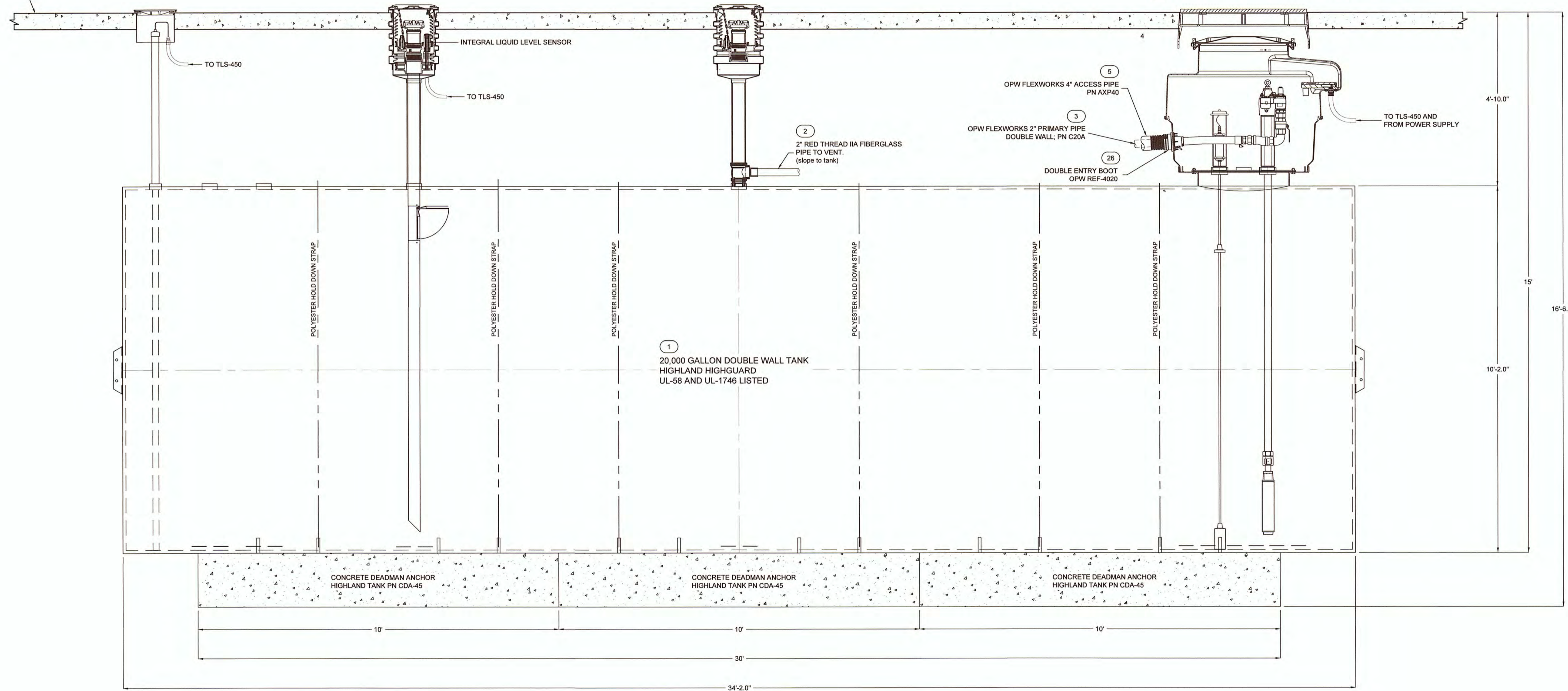

ELEVATION VIEW

TANK NO. 1

MATERIAL AND EQUIPMENT SHOWN ON THIS SHEET IS TO BE INCLUDED IN THE BASE BID. CONTRACTOR SHALL ENSURE COMATIBILITY OF THE LISTED COMPONENTS.

PROPOSED TANK ARRANGEMENT - UNLEADED GASOLINE UST

FINAL DESIGN
NOT RELEASED FOR CONSTRUCTION
WITHOUT APPROVAL FROM THE
DIVISION OF WASTE MANAGEMENT

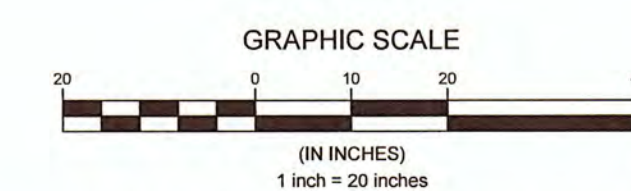

© 2022 HAGGETT ENGINEERING ASSOCIATES, INC.

FAYETTEVILLE PUBLIC WORKS COMMISSION
955 OLD WILMINGTON ROAD
FAYETTEVILLE, NORTH CAROLINA 28351
PROPOSED TANK ARRANGEMENT - UNLEADED GASOLINE UST

NO.	REVISION	DATE
1	added item numbers	02NOV22
2	interstitial sensor model	03JAN23

HAGGETT ENGINEERING ASSOCIATES, INC.
5307 SOUTH COLLEGE ROAD, SUITE 2B
WILMINGTON, NORTH CAROLINA 28412
PHONE: (910) 397-0808
LICENSE NO.: C-1111

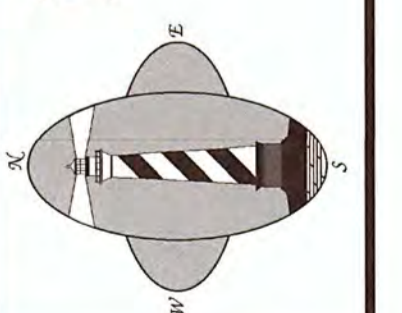

DRAWING:
C.3.1



3250 US Highway 70 Business West
Smithfield, NC 27577-6954
(919) 934-2786



Highland Tank

2700 Patterson Street
Greensboro, NC 27407
(336) 218-0801
Christopher Moore
cmoore@highlandtank.com

LEGEND

- XXX EXISTING ITEM NUMBER
- XX NEW ITEM NUMBER

INTERSTITIAL MONITOR:

- 7 OPW PN 104A-1200WT MANHOLE
- 8 VEEDER-ROOT PN 794380-333 SENSOR
- 9 VEEDER-ROOT PN 312020-928 2" SENSOR RISER CAP KIT

PRODUCT FILL:

- 10 OPW PN 1C-3132D DOUBLE WALL SPILL CONTAINER
- 11A OPW PN 7150-410CB OVERFILL PREVENTION VALVE (B100)
- 12 OPW PN 633T-8075 FILL ADAPTER
- 13 OPW PN 633LC-1000 LOCK CLAMP (2)
- 14 OPW PN 634TT-785-EVR FILL CAP

VAPOR RECOVERY:

- 15 OPW PN 1C-3101D SINGLE WALL SPILL CONTAINER
- 16 OPW PN 233-4420 EXTRACTOR FITTING
- 17 OPW PN 61VSA-1020-EVR VAPOR RECOVERY ADAPTER
- 18 OPW PN 1711T-7085-EVR VAPOR RECOVERY CAP

STP CONTAINMENT:

- 4 OPW PN FCSM-1-4233CR TANK SUMP
- 19 OPW PN 42MAT-PL12 MANHOLE
- 20 VEEDER-ROOT PN 846396-110 FUEL PROBE WITH 846400-101 DIESEL FUEL FLOAT KIT
- 21A VEEDER-ROOT PN AGP150S1 RJ2 SUBMERGED TURBINE PUMP
- 22 OPW PN FC20-MM12 FLEXIBLE CONNECTOR, STAINLESS STEEL
- 23 OPW FULL PN 21BV-0200 FULL PORT BALL VALVE
- 24 VEEDER-ROOT PN AGP150S1 RJ2 SUBMERGED TURBINE PUMP
- 25 VEEDER-ROOT PN 859080-001 DIGITAL PRESSURE LINE LEAK DETECTOR
- 26 VEEDER-ROOT PN 794380-208 LIQUID LEVEL SENSOR

CONCRETE SURFACE
(no motor vehicles)

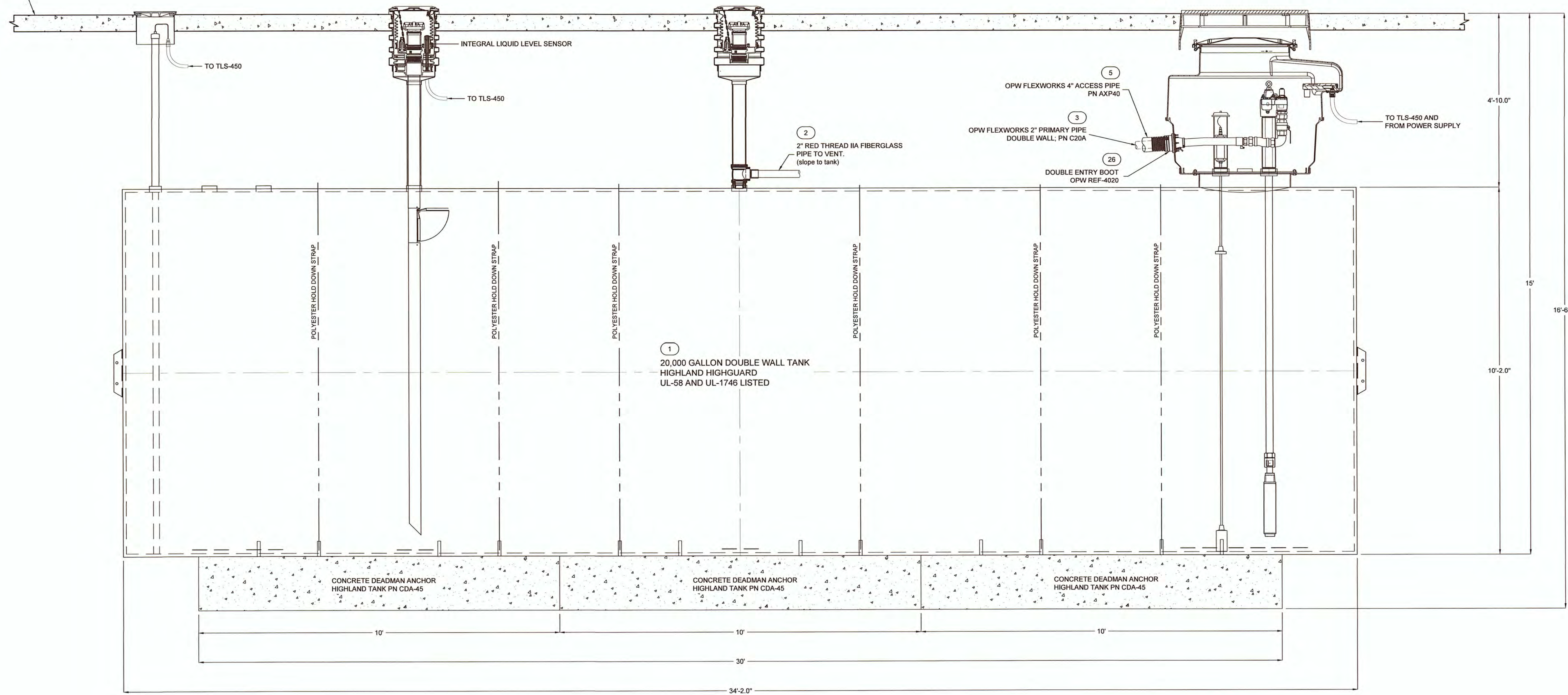

ELEVATION VIEW

TANK NO. 2

MATERIAL AND EQUIPMENT SHOWN ON THIS SHEET IS TO BE INCLUDED IN THE BASE BID. CONTRACTOR SHALL ENSURE COMPATIBILITY OF THE LISTED COMPONENTS.

PROPOSED TANK ARRANGEMENT - DIESEL FUEL UST

FINAL DESIGN
NOT RELEASED FOR CONSTRUCTION
WITHOUT APPROVAL FROM THE
DIVISION OF WASTE MANAGEMENT

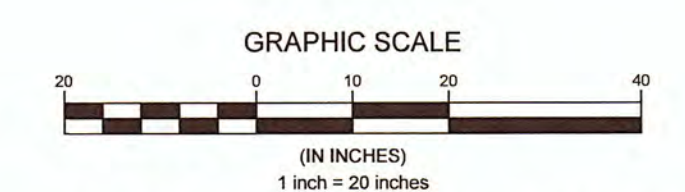

© 2022 HAGGETT ENGINEERING ASSOCIATES, INC.

FAYETTEVILLE PUBLIC WORKS COMMISSION
955 OLD WILMINGTON ROAD
FAYETTEVILLE, NORTH CAROLINA 28351
PROPOSED TANK ARRANGEMENT - DIESEL FUEL UST

NO.	REVISION	DATE
1	added item numbers	02NOV22
2	interstitial sensor model	03JAN23

HAGGETT ENGINEERING ASSOCIATES, INC.
5307 SOUTH COLLEGE ROAD, SUITE 2B
WILMINGTON, NORTH CAROLINA 28412
PHONE: (910) 397-0808
LICENSE NO.: C-1111

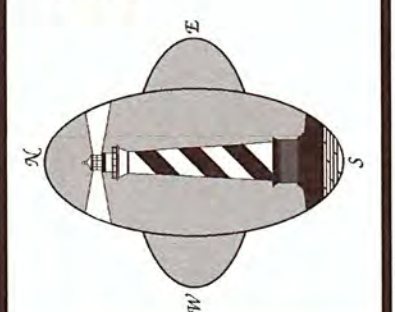

DRAWING:
C.3.2



3250 US Highway 70 Business West
Smithfield, NC 27577-6954
(919) 934-2786

LEGEND

- xxx EXISTING ITEM NUMBER
- xx NEW ITEM NUMBER



Highland Tank

2700 Patterson Street
Greensboro, NC 27407
(336) 218-0801
Christopher Moore
cmoore@highlandtank.com

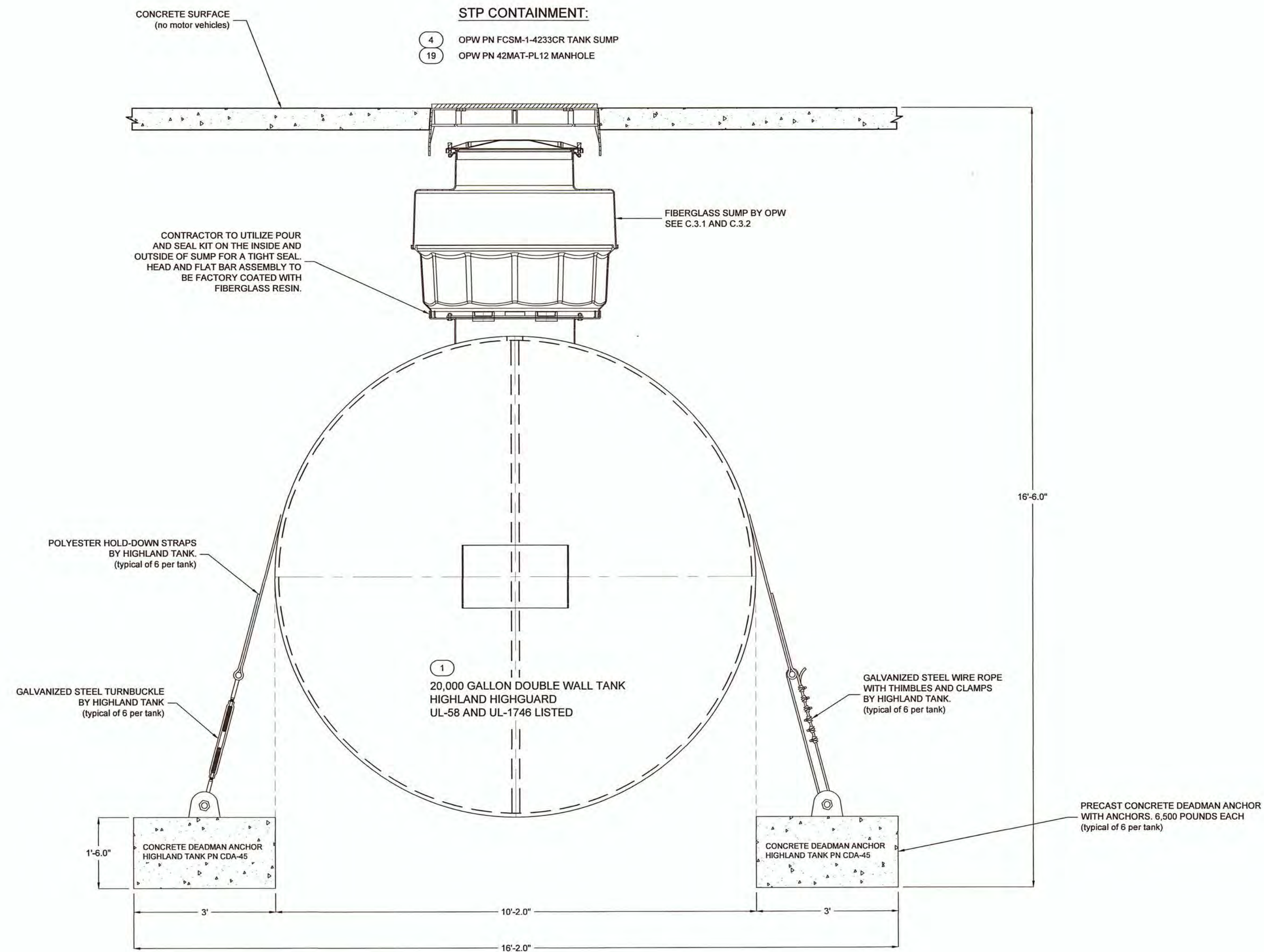

END VIEW

MATERIAL AND EQUIPMENT SHOWN ON THIS SHEET IS TO BE INCLUDED IN THE BASE BID. CONTRACTOR SHALL ENSURE COMATIBILITY OF THE LISTED COMPONENTS.

PROPOSED TANK ARRANGEMENT - TYPICAL UST

FINAL DESIGN
NOT RELEASED FOR CONSTRUCTION WITHOUT APPROVAL FROM THE DIVISION OF WASTE MANAGEMENT

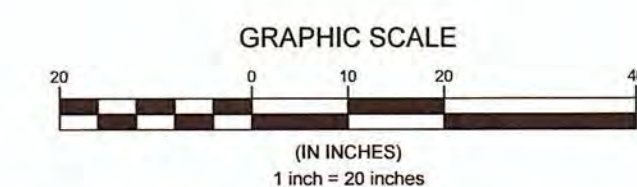

© 2022 HAGGETT ENGINEERING ASSOCIATES, INC.

FAYETTEVILLE PUBLIC WORKS COMMISSION
955 OLD WILMINGTON ROAD
FAYETTEVILLE, NORTH CAROLINA 28351
PROPOSED TANK ARRANGEMENT - TYPICAL UST

NO.	REVISION	DATE
1	added item numbers	08/02/22

HAGGETT ENGINEERING ASSOCIATES, INC.
5307 SOUTH COLLEGE ROAD, SUITE 2B
WILMINGTON, NORTH CAROLINA 28412
PHONE: (910) 397-0808
LICENSE NO.: C-1111

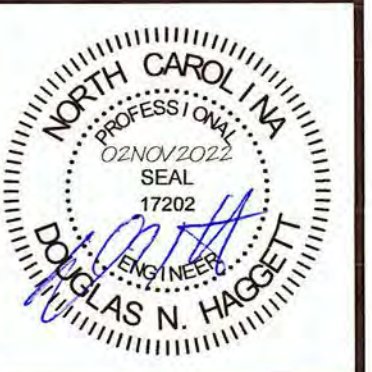
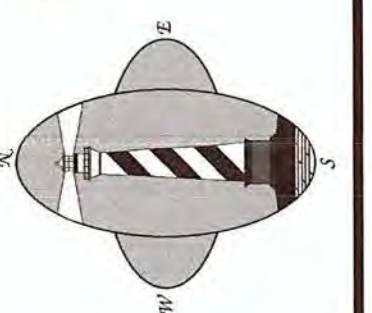

DRAWING:
C.3.3

LEGEND

- xxx EXISTING ITEM NUMBER
- xx NEW ITEM NUMBER

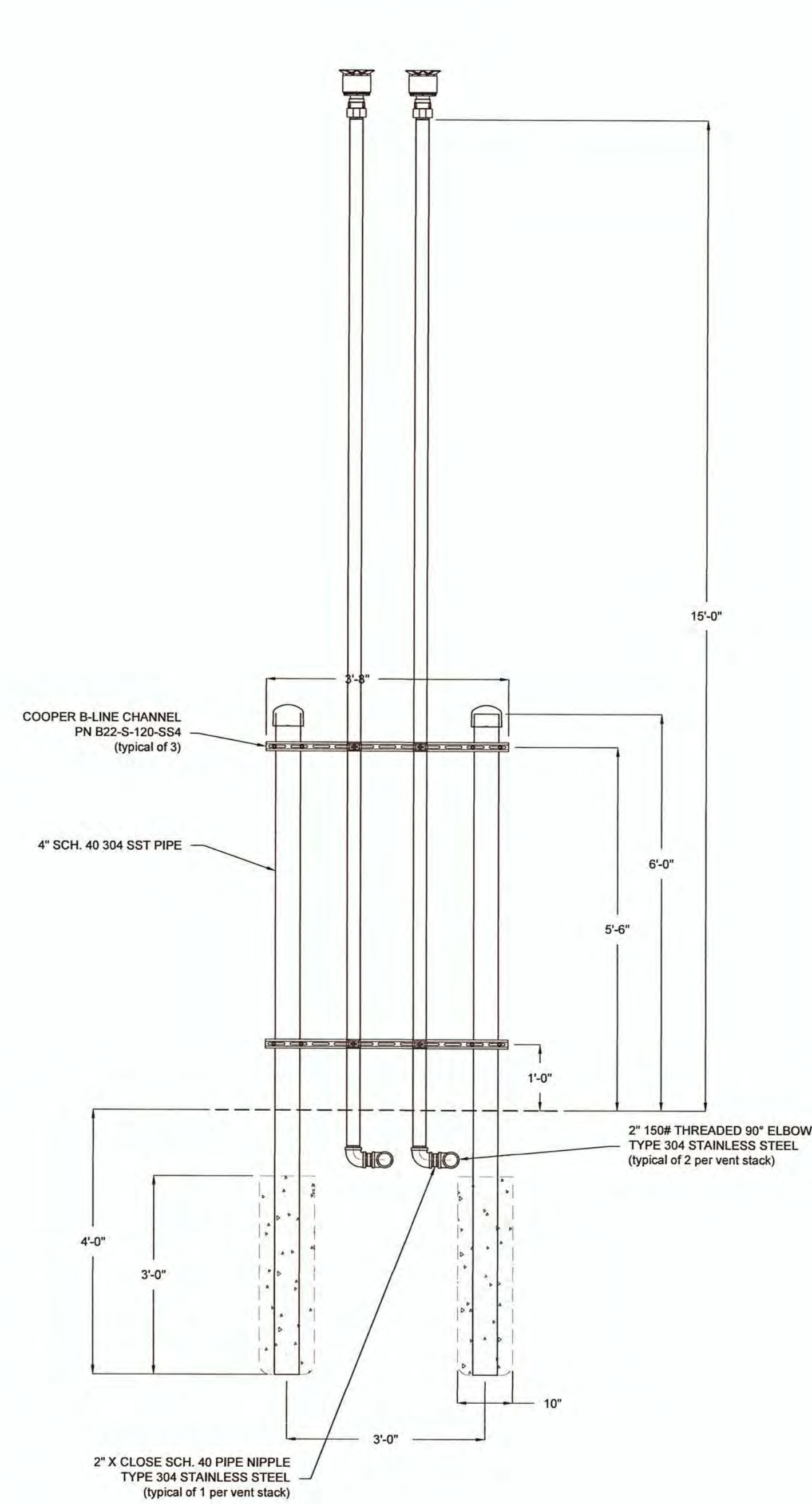

FRONT VIEW

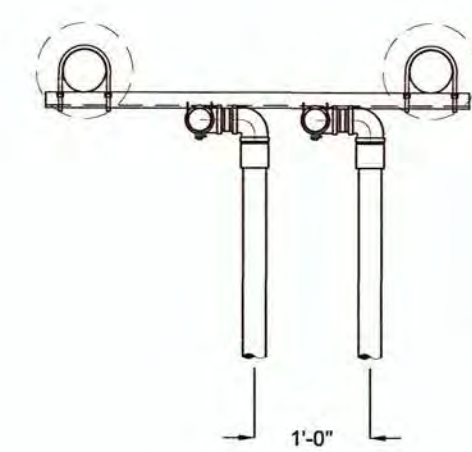

PLAN VIEW

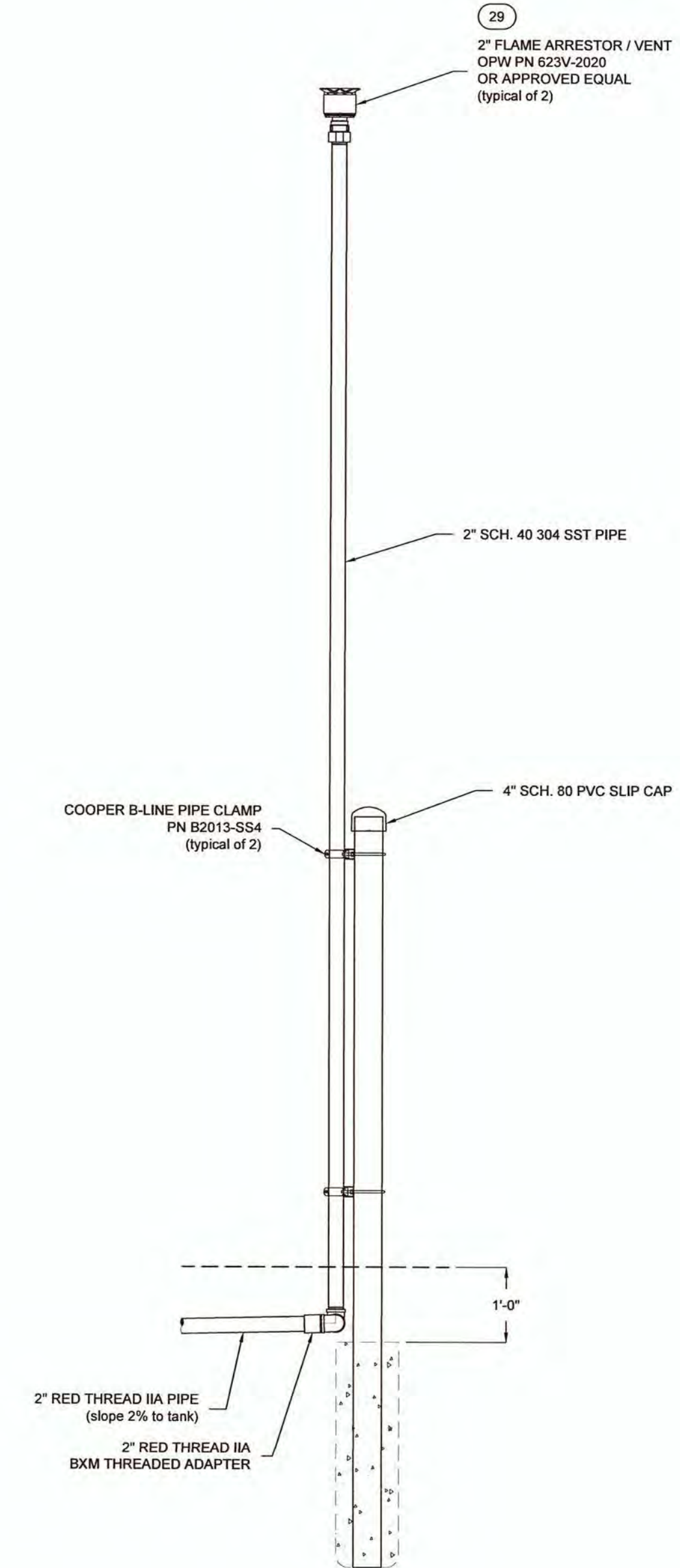

ELEVATION VIEW

FINAL DESIGN
 NOT RELEASED FOR CONSTRUCTION
 WITHOUT APPROVAL FROM THE
 DIVISION OF WASTE MANAGEMENT

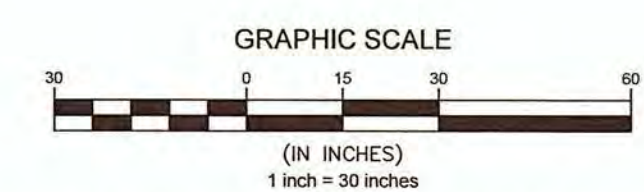

© 2022 HAGGETT ENGINEERING ASSOCIATES, INC.

FAYETTEVILLE PUBLIC WORKS COMMISSION
 955 OLD WILMINGTON ROAD
 FAYETTEVILLE, NORTH CAROLINA 28351

UST VENT ASSEMBLY - INSTALLATION DETAILS

SCALE: AS SHOWN

DATE: 18OCT2022

CHECKED BY:

DESIGN: DOUG HAGGETT

NO.	REVISION	DATE
1	added item numbers	08NOV22

PROJECT NO.: 20-1019

HAGGETT ENGINEERING ASSOCIATES, INC.
 5307 SOUTH COLLEGE ROAD, SUITE 2B
 WILMINGTON, NORTH CAROLINA 28412
 PHONE: (910) 397-0808
 LICENSE NO.: C-1111

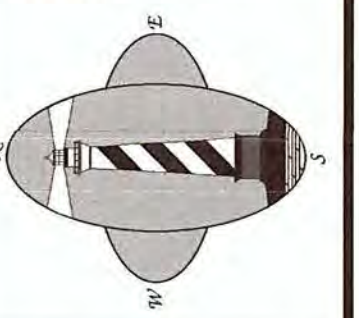

DRAWING:
C.4.1

LEGEND

- XXX EXISTING ITEM NUMBER
- XX NEW ITEM NUMBER

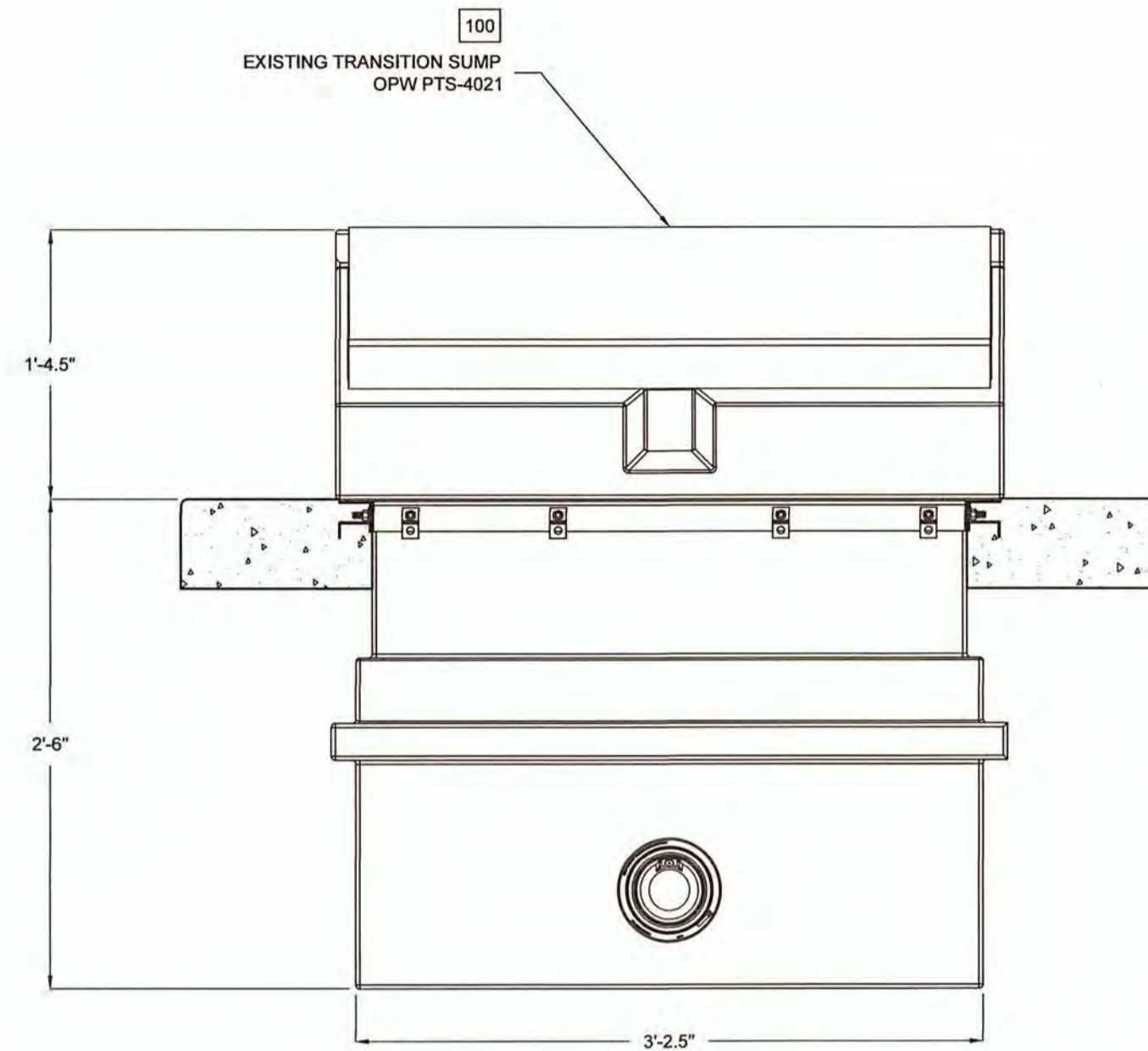

FRONT VIEW
(FACING COMMISSION DRIVE)

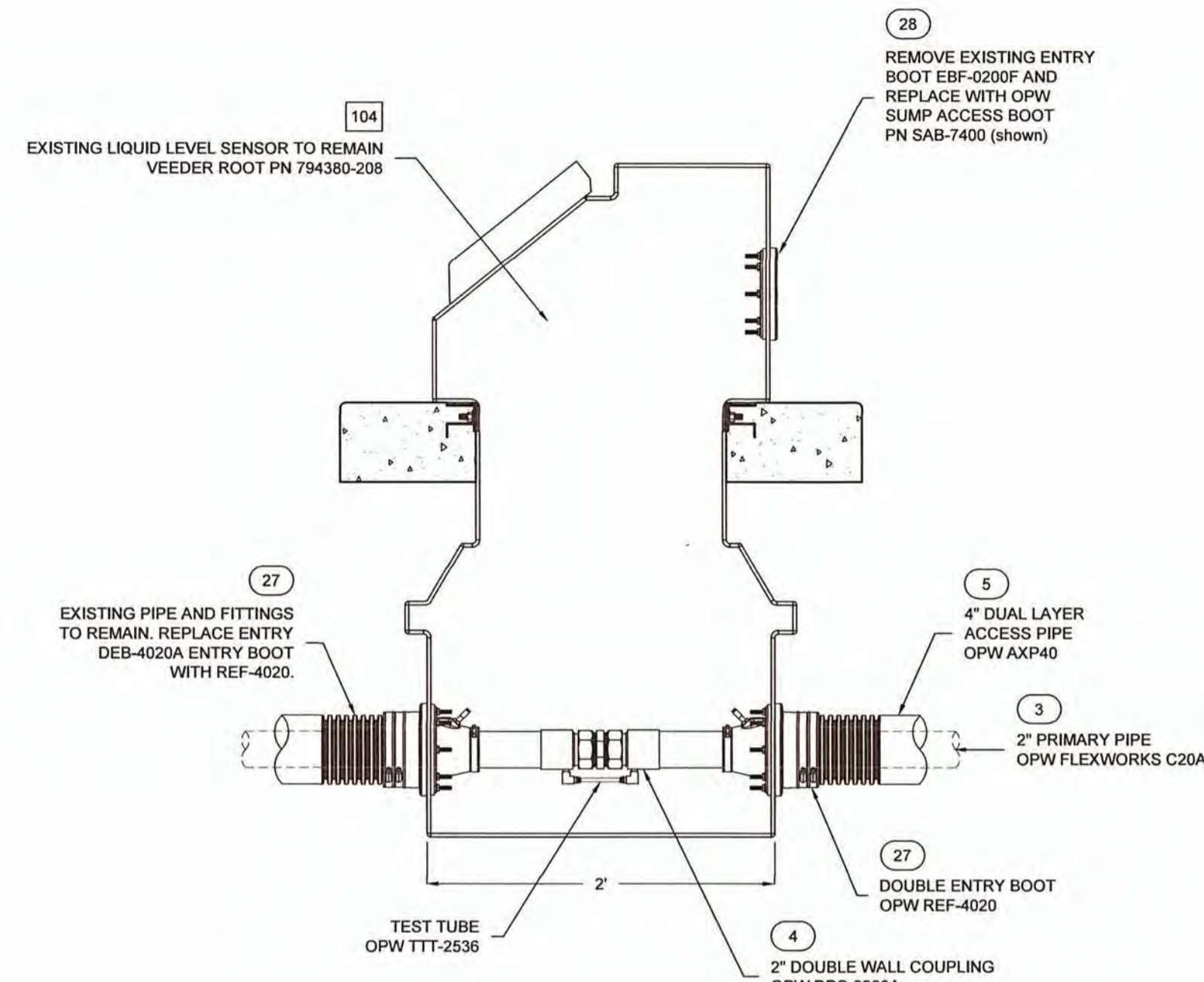

ELEVATION
TYPICAL FOR TWO TRANSITION SUMPS.

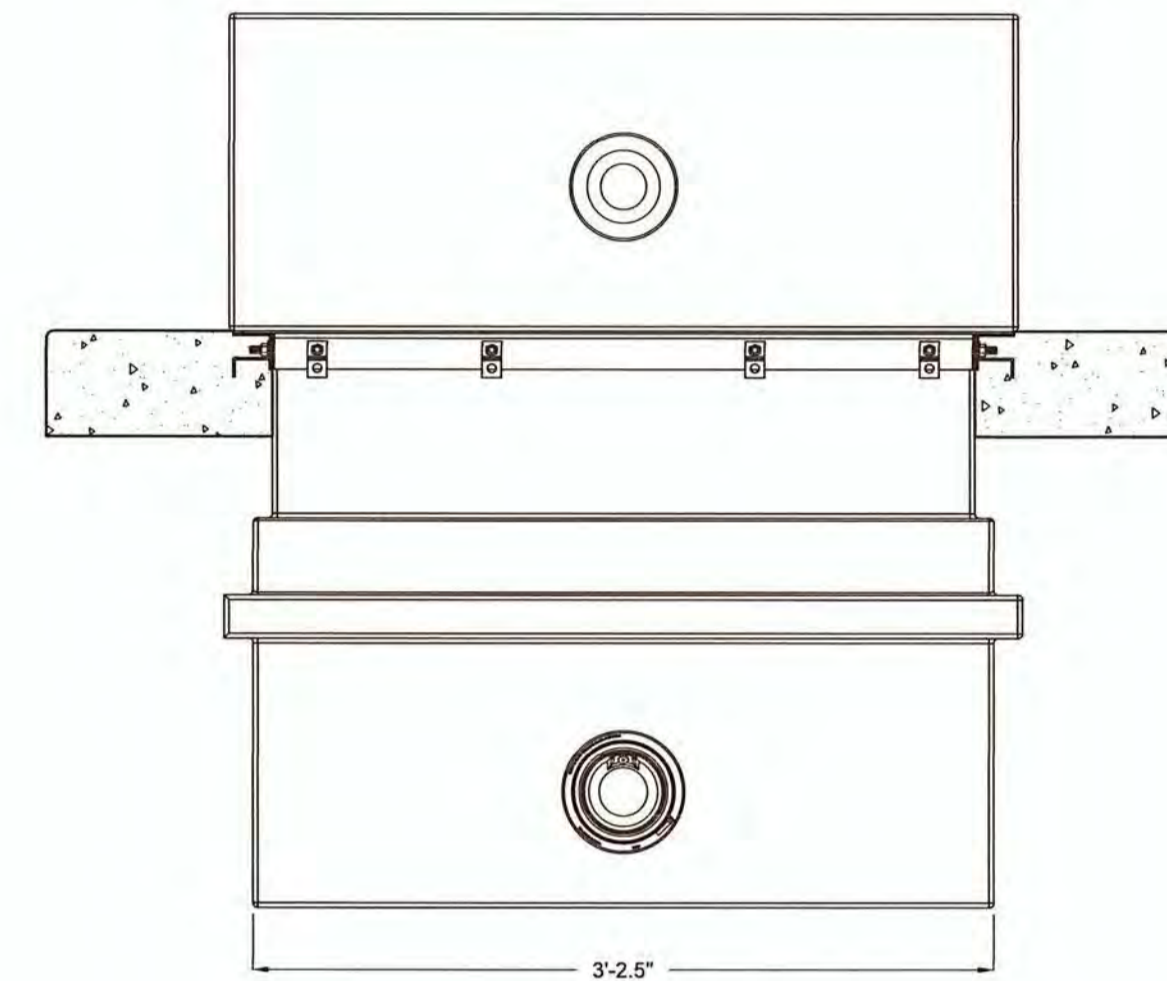

REAR VIEW

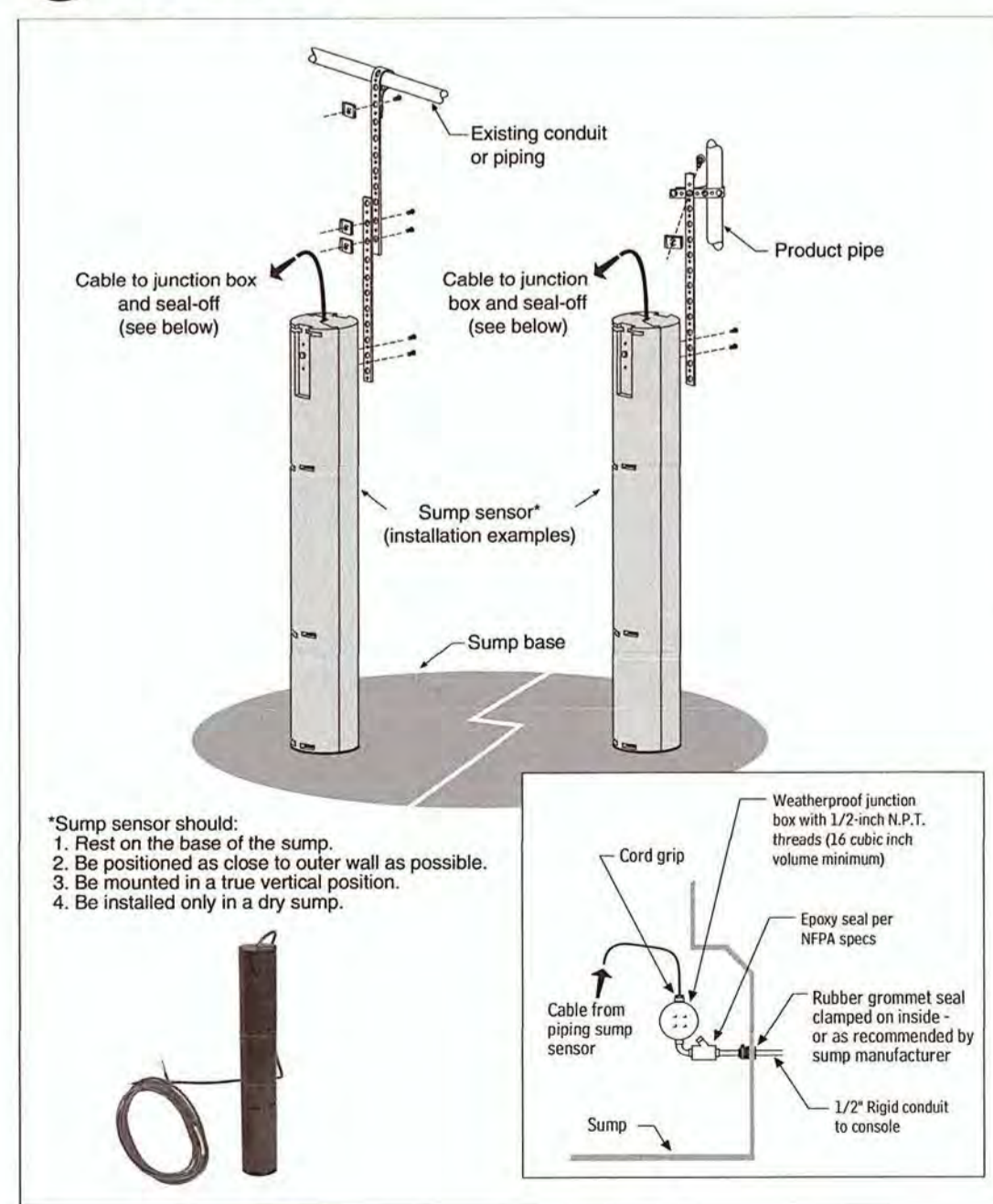

SUMP SENSOR INSTALLATION - DETAIL

EXISTING AND PROPOSED LIQUID LEVEL SENSORS.

TRANSITION SUMP NOTES:

PIPE ENTRIES

The installation of all flexible entry boots must be completed prior to the installation of the riser pipe assembly. Determine the correct pipe entry location in the bottom of the pan so that there is direct alignment with the dispenser inlet fitting.

PIPE & CONDUIT ENTRIES

All sump containers shall be fitted with pipe and conduit entry seals which are semi-absorbent to ground movement and sufficiently flexible enough to permit angled entries up to 15 degrees without leaking under liquid head pressures of up to three feet.

LIQUID TIGHTNESS

All sump containers shall prevent outside surface and ground water from coming into the container and prevent any product originating from within the sump from escaping into the underground environment. OPW-FCS recommends hydrostatic testing on all sumps after installation to check for proper sealing of joints and connections.

HYDROSTATIC TESTING

OPW Fueling Containment Systems recommends the following procedure for hydrostatic testing of dispenser sumps, tank sumps and specialty application sumps.

- 1) Visually inspect all entry boots for band clamps, compression rings and donuts for possible leak points prior to connecting. Correct as needed.
- 2) Be sure all test tubes, connector tubes or any other open secondaries into the sump are sealed and liquid tight.
- 3) Fill all sumps to a minimum of 1" above the highest penetration fitting or sump joint. Mark the liquid level with a permanent marker. Sumps should be filled to the top whenever practical.
- 4) Hydrostatic test should be held for 1 hour or per local regulations. Testing shall be observed by the Owner and the Engineer.
- 5) Be sure all water is disposed of properly after completing the test.

Note: Should the liquid level drop during testing, visually identify the leak source. Remove water and tighten band clamps to 30 in/lbs. Entry boot compression rings should be tightened in a clockwise manner until each stud reaches 60in/lbs. Do not over-tighten compression rings. Repeat testing procedure.

TRANSITION SUMP - MODIFICATION DETAILS

FINAL DESIGN
NOT RELEASED FOR CONSTRUCTION
WITHOUT APPROVAL FROM THE
DIVISION OF WASTE MANAGEMENT

HAGGETT ENGINEERING ASSOCIATES, INC.

5307 SOUTH COLLEGE ROAD, SUITE 2B
WILMINGTON, NORTH CAROLINA 28412
PHONE: (910) 397-0808
LICENSE NO.: C-1111

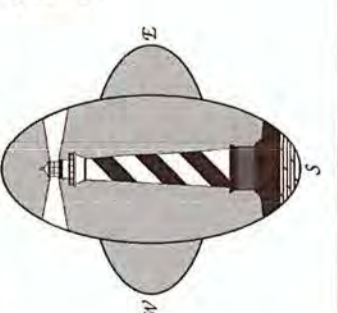

DRAWING:
C.5.1

NO.	REVISION	DATE
1	added item numbers	02/10/22

FAYETTEVILLE PUBLIC WORKS COMMISSION
955 OLD WILMINGTON ROAD
FAYETTEVILLE, NORTH CAROLINA 28351
TRANSITION SUMP - MODIFICATION DETAILS
DESIGN: DOUG HAGGETT CHECKED BY: DATE: 18OCT2022 SCALE: AS SHOWN

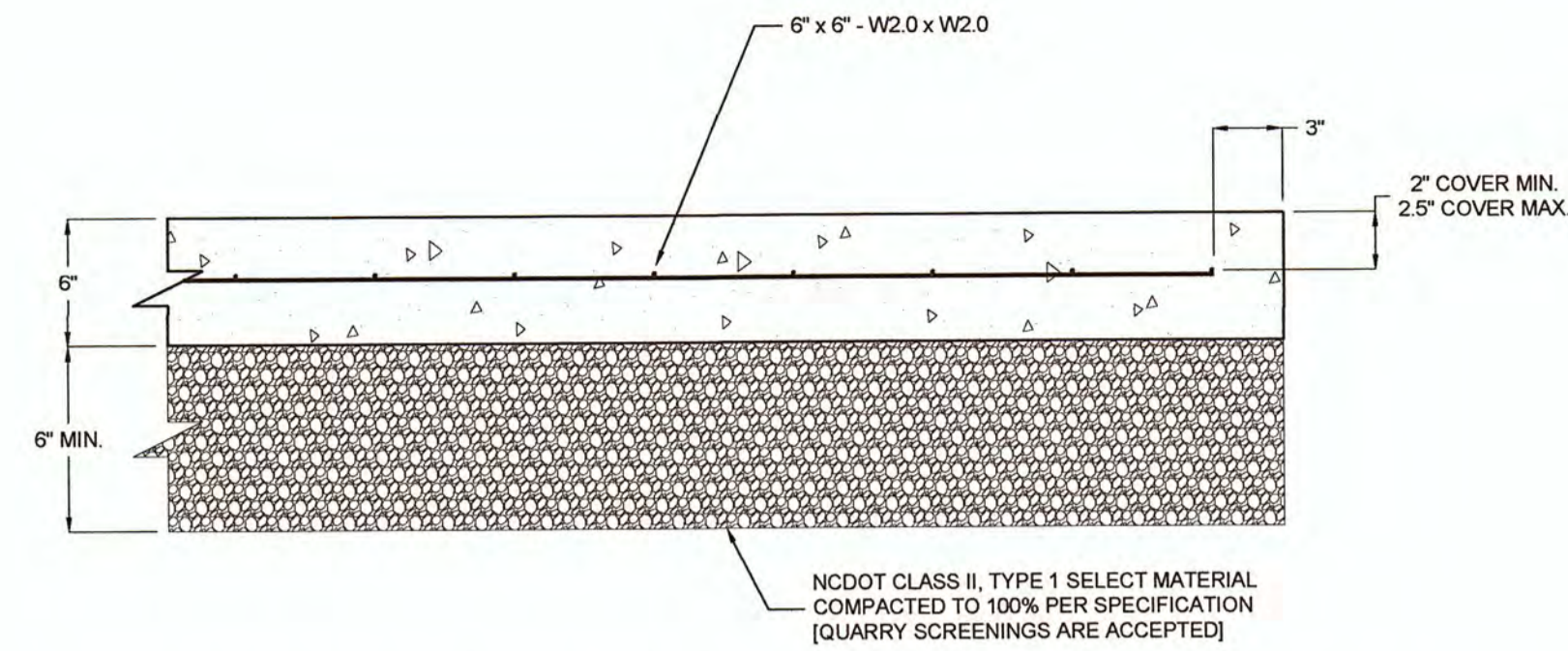

WIRE REINFORCED CONCRETE PAVEMENT - LIGHT DUTY (NON H20)

INSTALLATION OF WELDED WIRE REINFORCEMENT

1. WHEN WWR ROLLS ARE USED, ROLLS SHALL BE UNROLLED, CUT TO PROPER LENGTH AND TURNED OVER TO PREVENT THE ENDS FROM CURLING.
2. FLATTENING OF THE WWR IS BEST ACCOMPLISHED MECHANICALLY (ROLLER STRAIGHTENER) WHICH WILL PROVIDE THE NECESSARY FLATNESS TO ACHIEVE PROPER POSITIONING.
3. ALL WWR SHALL BE PLACED ON SUPPORT ACCESSORIES TO MAINTAIN THE REQUIRED POSITION AND COVER AS SPECIFIED ON THE APPROVED PLANS.
4. WWR SHALL NOT BE PLACED ON THE SUB GRADE AND PULLED UP DURING CONCRETE PLACEMENT.
5. SUPPORT ACCESSORIES MAY BE STEEL (COATED OR UNCOATED) AND PLASTIC CHAIRS, BOLSTERS AND WWR SUPPORT ACCESSORIES MADE SPECIFICALLY FOR SINGLE OR DOUBLE LAYER REINFORCING APPLICATIONS.
6. SUPPORT ACCESSORIES SHALL BE SPACED 2' TO 3' APART WHEN USING LIGHT WWR STYLES; W1.4 OR D10 TO W2.0 OR D8.
7. DO NOT PLACE CONCRETE UNTIL THE ENGINEER HAS INSPECTED AND APPROVED THE PLACEMENT OF THE REINFORCEMENT.

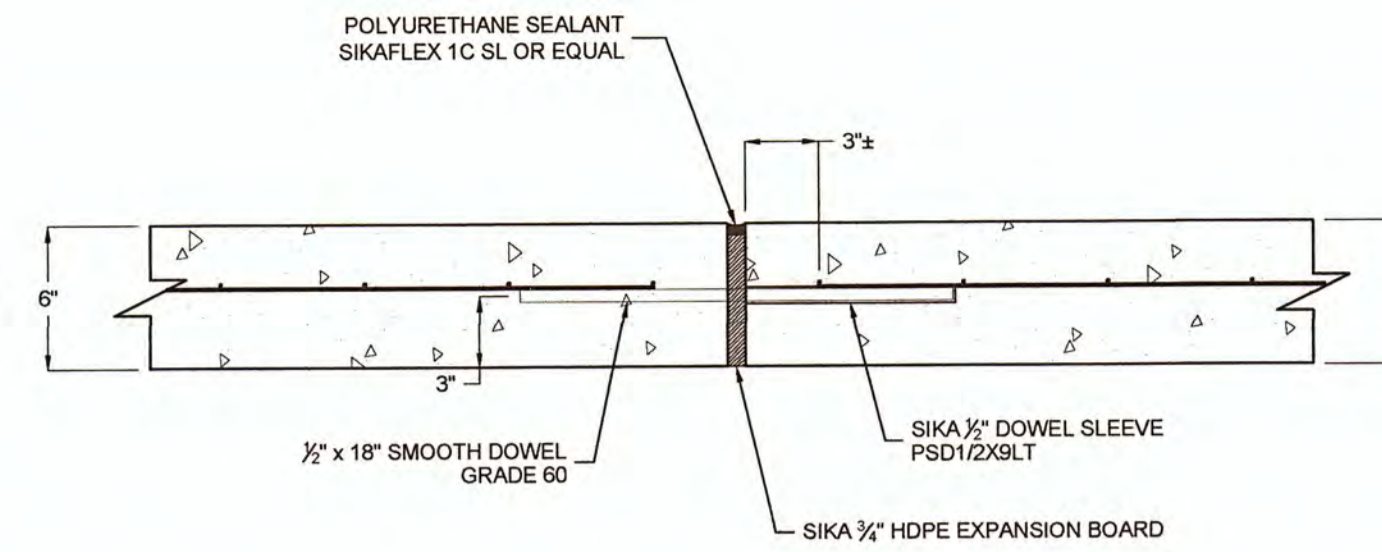

EXPANSION JOINT - LIGHT DUTY CONCRETE PAVEMENT (NON H20)

1. INTERRUPT WWR AT EXPANSION JOINT AS SHOWN.
2. APPLY POLYURETHANE SEALANT TO CLEAN DRY CONCRETE. ALLOW A MINIMUM OF 48-HOURS CURE TIME FOR NEW CONCRETE.

FAYETTEVILLE PUBLIC WORKS COMMISSION
 955 OLD WILMINGTON ROAD
 FAYETTEVILLE, NORTH CAROLINA 28351

NO.	REVISION	DATE

HAGGETT ENGINEERING ASSOCIATES, INC.
 5307 SOUTH COLLEGE ROAD, SUITE 2B
 WILMINGTON, NORTH CAROLINA 28412
 PHONE: (910) 397-0808
 LICENSE NO.: C-1111

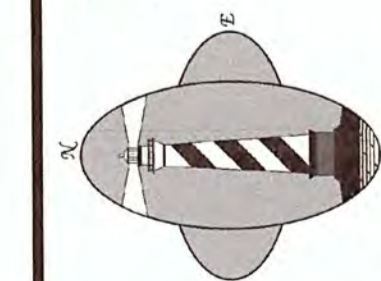

DRAWING: **C.6.1**

DESIGN: DOUG HAGGETT CHECKED BY: SCALE: AS SHOWN DATE: 18OCT2022

PROJECT NO.: 22-1009

FINAL DESIGN
 NOT RELEASED FOR CONSTRUCTION
 WITHOUT APPROVAL FROM THE
 DIVISION OF WASTE MANAGEMENT

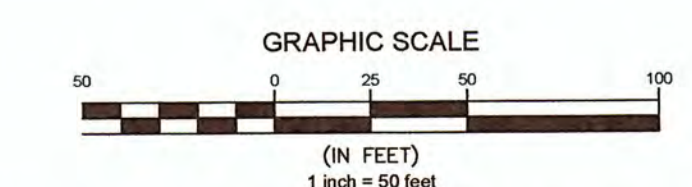

CONCRETE PAVEMENT DETAILS

© 2022 HAGGETT ENGINEERING ASSOCIATES, INC.

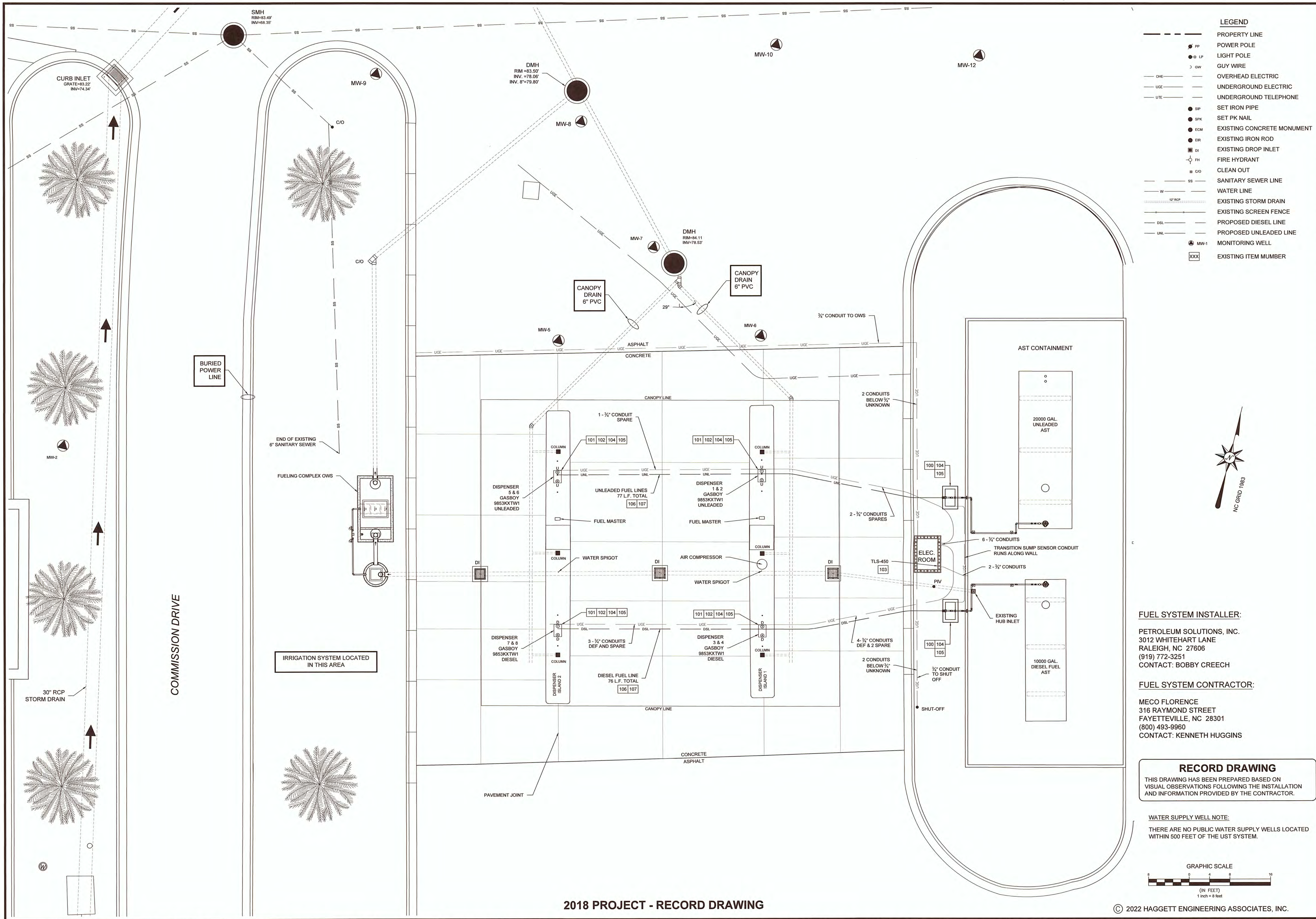

- LEGEND**
- PROPERTY LINE
 - PP POWER POLE
 - LP LIGHT POLE
 - GW GUY WIRE
 - OHE OVERHEAD ELECTRIC
 - UGE UNDERGROUND ELECTRIC
 - UTE UNDERGROUND TELEPHONE
 - SPK SET IRON PIPE
 - SPK SET PK NAIL
 - ECM EXISTING CONCRETE MONUMENT
 - ERR EXISTING IRON ROD
 - DI EXISTING DROP INLET
 - FH FIRE HYDRANT
 - CO CLEAN OUT
 - SS SANITARY SEWER LINE
 - W WATER LINE
 - 1" RCP EXISTING STORM DRAIN
 - DSL PROPOSED DIESEL LINE
 - UNL PROPOSED UNLEADED LINE
 - MW-1 MONITORING WELL
 - XXX EXISTING ITEM NUMBER



FUEL SYSTEM INSTALLER:
 PETROLEUM SOLUTIONS, INC.
 3012 WHITEHART LANE
 RALEIGH, NC 27606
 (919) 772-3251
 CONTACT: BOBBY CREECH

FUEL SYSTEM CONTRACTOR:
 MECO FLORENCE
 316 RAYMOND STREET
 FAYETTEVILLE, NC 28301
 (800) 493-9960
 CONTACT: KENNETH HUGGINS

RECORD DRAWING
 THIS DRAWING HAS BEEN PREPARED BASED ON VISUAL OBSERVATIONS FOLLOWING THE INSTALLATION AND INFORMATION PROVIDED BY THE CONTRACTOR.

WATER SUPPLY WELL NOTE:
 THERE ARE NO PUBLIC WATER SUPPLY WELLS LOCATED WITHIN 500 FEET OF THE UST SYSTEM.

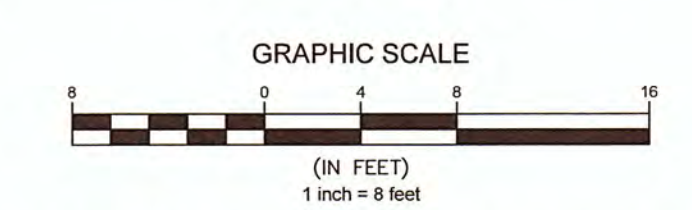

FAYETTEVILLE PUBLIC WORKS COMMISSION
 955 OLD WILMINGTON ROAD
 FAYETTEVILLE, NORTH CAROLINA 28351
 2018 PROJECT - RECORD DRAWING

NO.	REVISION	DATE
1	water supply well note	03 JAN 23

HAGGETT ENGINEERING ASSOCIATES, INC.
 5307 SOUTH COLLEGE ROAD, SUITE 2B
 WILMINGTON, NORTH CAROLINA 28412
 PHONE: (910) 397-0808
 LICENSE NO.: C-1111

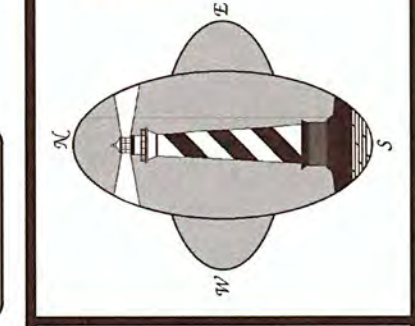

DRAWING:
C.7.1

2018 PROJECT - RECORD DRAWING

© 2022 HAGGETT ENGINEERING ASSOCIATES, INC.

APPENDIX B – PERMIT

ROY COOPER
Governor
ELIZABETH S. BISER
Secretary
MICHAEL SCOTT
Director



January 23, 2023

To: Henry Smith
Fayetteville Public Works Commission
P.O. Box 1089
Fayetteville NC 28302

Contractor: TBD

Engineer: Douglas N. Haggett, P.E.
Haggett Engineering Associates, Inc.
P.O. Box 15104
Wilmington, NC 28408

Subject: UST-6 “Application to Install or Replace Underground Storage Tank Systems (Pre-Installation)”
Fayetteville Public Works Commission (PWC)
955 Old Wilmington Road
Fayetteville, NC 28301
Facility ID: 00-0-0000047561

Mr. Smith,

The North Carolina Department of Environmental Quality (NCDEQ) – Underground Storage Tank (UST) Section has reviewed the UST-6 “Application to Install or Replace Underground Storage Tank Systems (Pre-Installation)”, received 11/03/2022, with additional information received on 01/03/2023 and 01/19/2023, proposing the installation of tanks and piping at the above location. Based on your submittal, your application to install or replace UST systems or UST system components at the above location is approved.

This approval is limited to the UST system and UST system components specified in the aforementioned application. Any modifications to the approved application must be approved by the design engineer. Significant modifications need to be submitted to NCDEQ for review and approval prior to installation (see enclosed “Guidance on UST-6A Modifications” for additional information).

Be advised, all UST system components must be installed and tested in accordance with the manufacturer’s written guidelines, PEI/RP100 “Recommended Practices for Installation of Underground Liquid Storage Systems” and Title 15A North Carolina Administrative Code, Subchapter 02N “Criteria and Standards Applicable to Underground Storage Tanks” (15A NCAC 02N). All new UST system piping, including tank manifolds (siphon bars) and remote fills, must have a line tightness test (LTT) conducted at the time of installation. New and existing automatic line leak detectors (ALLD) associated with any new piping being installed must also be tested. Additionally, leak detection sensors (e.g., sump sensors) being used to monitor the new UST system components (e.g., double-walled piping) must be tested for operability and proper setup, in accordance with the manufacturer’s written guidelines.

Be advised, new UST systems and UST system components cannot be installed in areas where it will be in contact with contaminated soil or free product. If evidence of a release has been discovered or confirmed, the UST Section Regional Office Corrective Action Branch must be notified and initial response/abatement activities must be completed prior to initiating UST installation or replacement activities. Please refer to the UST Section’s website (<https://deq.nc.gov/about/divisions/waste-management/underground-storage-tanks-section>) for UST Section Regional



North Carolina Department of Environmental Quality | Division of Waste Management
217 West Jones Street | 1646 Mail Service Center | Raleigh, North Carolina 27699-1646
919.707.8200

Office locations/contact information and for the UST Section's Guidelines for Site Checks, Tank Closure and Initial Response and Abatement for UST Releases.

During the installation of your UST system, you are required to schedule an installation inspection with UST Section personnel. The following phase(s) of the UST system installation must be inspected:

1. Exterior tank surface inspection and tank integrity testing prior to placing the tank into the excavation; and
2. Testing of all piping, fittings and containment sumps prior to burial of the product piping. Note that the detectable tape (specified on the UST-6C form) must be on-site during this inspection.

The UST inspector for the required inspection(s) is Gina Williams and they can be reached at (910) 567-5683. To ensure that a mutually convenient inspection date can be arranged, please contact the inspector prior to finalizing the schedule of the installation activity, such as scheduling tank delivery, crane rental, etc. You must provide one or more weeks' notice to have a better chance that your proposed installation date is open on the inspector's calendar. If the regular inspector does not return your voicemail or e-mail within 24 hours, the alternate contact for installation inspections is Michael Phelps (Environmental Supervisor) who can be contacted at (336) 776-9684. Note: Inspections cannot be scheduled for weekends or state holidays.

Please be advised, within thirty days of the completion of installation activities, an electronic copy, in PDF format, of the UST-6 "Application to Install or Replace Underground Storage Tank Systems (Post-Installation)" documenting the installation work and testing must be submitted to deq.wm.ust-installation@ncdenr.gov to NDEQ-UST Section (Central Office) for review.

Sincerely,

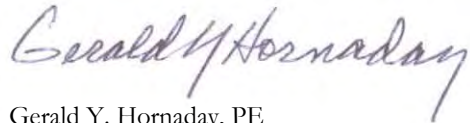

Gerald Y. Hornaday, PE
Engineer
North Carolina Department of Environmental Quality
Division of Waste Management
Underground Storage Tank Section
(919) 707-8162
Email: Gerald.Hornaday@ncdenr.gov

Enclosures: Guidance on UST-6A Modifications

cc: Gina Williams - UST Inspector
 Registration File



North Carolina Department of Environmental Quality | Division of Waste Management
217 West Jones Street | 1646 Mail Service Center | Raleigh, North Carolina 27699-1646
919.707.8200

UST-6

Application to Install or Replace Underground Storage Tank Systems (Pre/Post-Installation)



Facility ID No.:
00-0-0000047561

Is this an existing facility? Yes No

INSTRUCTIONS: This form is used to: (1) document the proposed installation of regulated Underground Storage Tanks (UST) and/or piping in North Carolina, referred to as the UST-6A, and (2) certify the specifics of the installation once it is complete, referred to as the UST-6B. Please type or print all items except signature. If more than four (4) UST systems are being installed at the facility, photocopy the necessary additional sheets and staple to this form.

1. Type of Notification		STATE USE ONLY	
1.1	<input checked="" type="checkbox"/> Pre-Installation Notification (UST-6A)	Projected Installation Start Date: 2/15/2023	UST-6A Reviewer Name: Gerald Y. Hornaday
		UST System components to be installed (Check one): <input checked="" type="checkbox"/> Tanks and Piping <input type="checkbox"/> Piping Only <input type="checkbox"/> Tanks Only <input type="checkbox"/> Piping Only (Emergency)* *[A letter of emergency justification must be provided]	UST-6A Approved: <input checked="" type="checkbox"/> Yes <input type="checkbox"/> No Date UST-6A Approved/Disapproved: 01/23/2023 UST-6B Reviewer Name:
1.2	<input type="checkbox"/> Post-Installation Notification (UST-6B)	Date Installation Completed:	UST-6B Approved: <input type="checkbox"/> Yes <input type="checkbox"/> No
		Were there any modifications made to the approved UST-6A design (Check one): <input type="checkbox"/> Yes <input type="checkbox"/> No	Date UST-6B Approved/Disapproved:

2. Ownership of UST System			3. Operator of UST System		
Owner Name (Corporation, Individual, Public Agency, or Other Entity) Fayetteville Public Works Commission			Operator Name (Corporation, Individual, Public Agency, or Other Entity) Fayetteville Public Works Commission		
Contact Name (if not named above) Henry Smith			Contact Name (if not named above) Henry Smith		
Mailing Address P.O. Box 1089			Mailing Address P.O. Box 1089		
City Fayetteville	State NC	Zip 28302	City Fayetteville	State NC	Zip 28302
Phone Number (910) 233-4670	Email Address henry.smith@faypwc.com		Phone Number (910) 233-4670	Email Address henry.smith@faypwc.com	

Check here if "Real" Property Owner of Site

Type of UST Owner (check all that apply): State Gov't Local Gov't Private/Corporate Federal Gov't GSA Facility ID

4. Location of UST System

Facility Name or Company: Fayetteville Public Works Commission Check if tanks located on Indian lands or reservation

Street Address (if street address has not been assigned, then provide county tax map number or street intersection):
955 Old Wilmington Road

City: Fayetteville State: NC Zip: 28301

County: Cumberland Phone Number: (910) 223-4670 Email Address: henry.smith@faypwc.com

5. North Carolina Professional Engineer			6. Main UST System Installation Contractor		
PE Name Douglas N. Haggett		PE License No. 17202	Contractor Name To Be Determined		
Company Name Haggett Engineering Associates, Inc.			Project Manager Name (if not named above)		
Mailing Address P.O. Box 15104			Mailing Address		
City Wilmington	State NC	Zip 28408	City	State	Zip
Phone Number (910) 397-0808	Fax Number N/A		Phone Number	Fax Number	
Email Address haggettengineeri@bellsouth.net			Email Address		

UST-6

Application to Install or Replace Underground Storage Tank Systems (Pre/Post-Installation)



Please complete and attach this page when submitting a UST-6A (proposed installation).

7. Scope of the Proposed Work

7.1 Proposed Work - General

This UST-6A proposes the installation of UST system components as part of a(n):

- New UST Facility (Ground Up)
 Existing UST Facility - Expansion
 Existing UST Facility - Replacement of UST System Component(s)

7.2 Proposed Work - Components (to be filled out for non-ground up installations)

This UST-6A proposes the installation of the following UST components (check all that apply):

- Underground Storage Tanks
 Spill Prevention Equipment (e.g., spill buckets)
 Leak Detection Equipment (e.g., sump sensors, monitoring consoles)
- Piping
 Overfill Prevention Equipment (e.g., flapper valves, ball float vent restriction devices)
 Stage I Vapor Recovery Equipment
- Containment Sumps

8. Additional Description of the Proposed Work

For proposed installations that require additional description (e.g., complicated projects), please include additional details below. Also, if piping is being replaced at an existing facility, please explain reason for replacement and condition of other existing piping at facility, as applicable:

This project is to convert an existing AST system to a UST system. The underground piping and sumps for the existing AST system were completed in February 2019 and include approved double wall piping, dispenser sumps, transition sumps and sensors. In addition, the console for the leak detection system was upgraded to a TLS 450. Work included in this project includes the removal of the AST's and installation of two (2) 20,000 gallon double wall coated steel tanks complete with STP containment, spill buckets and vapor recovery. New piping will be limited to that required to connect from the STP's to the existing transition sumps and for the venting requirements. One tank will contain diesel fuel and the other regular unleaded gasoline. New dispensers were also installed in 2019.

NOTE: Per 15A NCAC 2N, no UST system or UST system component may be installed:

- Within 100 feet of a well serving a public water supply
- Within 50 feet of any other well used for human consumption
- Where it would be in contact with petroleum contaminated soils
- Where it would be in contact with free product

NOTE: "Existing" temporarily closed USTs must follow the requirements outlined in the temporary closure link below before the UST may return to service after a piping replacement. This includes the following USTs:

- USTs listed as being in temporary closure with NC DEQ
- USTs out of use for 90 or more days. This includes USTs that were in-use but the piping replacement takes longer than 90 days to complete or USTs where NC DEQ was not notified of the temporary closure.

https://files.nc.gov/ncdeq/Waste%20Management/DWM/UST/Brochures-FAQs/Brochure-Temporary_Closure.pdf

9. UST-6A Application Certification (Pre-Installation)

I certify, under penalty of law, that I have personally examined and am familiar with the information submitted in this and all attached documents; and that based on my inquiry of those individuals responsible for obtaining this information, I believe that the submitted information is true, accurate, and complete.

Marion Noland
 Print Name of Applicant
 Fayetteville Public Works Commission
 Company Name

 Applicant Signature

Interim Chief Executive Officer / General Manager
 Print Title of Applicant
 (910) 483-1382
 Telephone No.
 Date Signed

10. UST-6A Attachments (Pre-Installation)

Please attach the following items to this submittal (i.e., Pages 1 and 2).

10.1	Sections 11 through 17 (pages 3-7) of the UST-6 form detailing the proposed installation	<input checked="" type="checkbox"/> Yes	
10.2	An 11" x 17" scale drawing signed and sealed by a North Carolina Professional Engineer detailing the proposed installation	<input checked="" type="checkbox"/> Yes	
10.3	UST-6C, "Application to Install or Replace Underground Storage Tank Systems (Schedule of Materials)" signed and sealed by a North Carolina Professional Engineer	<input checked="" type="checkbox"/> Yes	
10.4	UST-15A, "Ownership of UST System(s)"	<input checked="" type="checkbox"/> Yes	
10.5	Proof of Financial Responsibility along with the Certification of Financial Responsibility form	<input type="checkbox"/> Yes	<input checked="" type="checkbox"/> Will be submitted after post-installation testing
10.6	Tank manufacturer's re-certification checklist. (Only required for "used" tanks being reinstalled)	<input type="checkbox"/> Yes	<input checked="" type="checkbox"/> N/A
10.7	UST-20, "Alternative Fuel /Hazardous Substances Compatibility Checklist" (Only required for > 20% Bio-Diesel, >10% Ethanol or Hazardous substances)	<input type="checkbox"/> Yes	<input checked="" type="checkbox"/> N/A

UST-6

Application to Install or Replace Underground Storage Tank Systems (Pre/Post-Installation)



11. Description of all Underground Storage Tanks (USTs) at this Facility

Instructions: Please complete Part 1 of this Section when submitting a UST-6A (proposed installation). Upon completion of installation, verify the information in Part 1 and revise as necessary, making sure to indicate those changes, and then complete Part 2. If there are more than four USTs at facility, please attach additional copies of this page.

PART 1 - PRE-INSTALLATION

11.1 UST - General					
11.1.1	TANK IDENTIFICATION NO. (e.g., A, B, C or 1, 2, 3; If compartment tank 1A, 1B, 1C, etc.)	Tank No. 1 (gasoline)	Tank No. 2 (diesel)	Tank No.	Tank No.
11.1.2	Indicate if tank is N= new, U=used, or E=existing ¹	New	New		
11.1.3	Capacity (gallons) If compartment tank, list compartment size.	20000	20000		

11.2 UST - Product Stored					
11.2.1	Product stored or to be stored (if other specify below) ²	Gasoline	Diesel		
11.2.2	If Other (specify)	N/A	N/A		
11.2.3	If hazardous substance, provide Chemical Abstract Service (CAS) number	N/A	N/A		

11.3 UST - Construction					
11.3.1	Tank manufacturer	Highland Tank Co	Highland Tank Co		
11.3.2	Tank model	Highguard	Highguard		
11.3.3	Materials of construction ³	DW Steel/Polyurethane	DW Steel/Polyurethane		
11.3.4	If other (specify)	N/A	N/A		
11.3.5	Check if tank is siphon manifolded and enter tank # it is manifolded with.	<input type="checkbox"/> /	<input type="checkbox"/> /	<input type="checkbox"/> /	<input type="checkbox"/> /

11.4 UST - Interstitial Monitoring (Leak Detection) ⁴					
11.4.1	Method of monitoring tank interstice ⁵	Liquid Detecting Sensor	Liquid Detecting Sensor		
11.4.2	Tank interstitial sensor manufacturer	Veeder-Root	Veeder-Root		
11.4.3	Tank interstitial sensor model	794380-333	794380-333		

PART 2 - POST-INSTALLATION

11.5 UST - Post Installation Certification (To Be Filled Out After Installation is Complete)					
11.5.1	Date of UST installation ⁶				
11.5.2	Tank UL (or serial) number				

¹ If UST is "used" attach a completed manufacturers re-certification checklist. If "existing", please fill out sections 11.1 and 11.2 at a minimum.

² Enter one of the following choices: Aviation Gas, Biodiesel (> 20%) - Diesel Mix*, Diesel, Ethanol (> 10%) -Gas Mix*, Fuel Oil, Gasoline, Hazardous Substance, Heating Oil, Kerosene, Motor Oil, Other Non-Petroleum, Other Petroleum, Transmission Fluid, or Used Oil
* Tanks with ≤20% Biodiesel should list the product as "Diesel" and tanks with ≤10% Ethanol should list the product as "Gasoline"

³ Enter one of the following choices: DW* FRP** (e.g. Xerxes, Containment Solutions), DW* Steel/FRP** (e.g. ACT-100), DW* Steel/Polyurethane (e.g. ACT-100-U), DW* Steel/Jacketed (e.g. Perm tank, Titan), Other

*DW = Double-walled **FRP = Fiberglass Reinforced Plastic

⁴ All tanks installed on or after November 1, 2007 must be of double-walled construction with continuous interstitial monitoring.

⁵ Enter one of the following choices: VM=Vacuum Sensor, PR=Pressure Sensor, HYDRO=Hydrostatic Float*, LDS=Liquid Detecting (dry) Sensor (usually position-sensitive)*, OTH=Other (specify type)
* Tanks using liquid detecting (dry) interstitial sensors must also be tested for tightness in accordance with 15A NCAC 02N.0903(f) & tanks using hydrostatic (wet) interstitial sensors must be dual-float to monitor both low & high level alarm conditions.

⁶ For consistency, please use the same installation date as recorded on the tank manufacturer's installation checklists.

UST-6

Application to Install or Replace Underground Storage Tank Systems (Pre/Post-Installation)



12. Description of All Piping Systems at this Facility

Instructions: Please complete Part 1 of this Section when submitting a UST-6A (proposed installation). Upon completion of installation, verify the information in Part 1 and revise as necessary, making sure to indicate those changes, and then complete Part 2. If there will be piping associated with more than four USTs, more than four different types of piping installed, etc., please attach additional copies of this page.

PART 1 - PRE-INSTALLATION

12.1 Piping System - General

12.1.1	Tank # (associated with piping) ¹	Tank No. 1 (gasoline)	Tank No. 2 (diesel)		
12.1.2	Indicate if piping is N=new or E=existing ²	New	New		
12.1.3	Indicate piping use/application ³	Product Distribution	Product Distribution		
12.1.4	If other (specify)	N/A	N/A		
12.1.5	Piping configuration (PR=Pressurized, SU=Suction, SI=Siphon or GR=Gravity)	Pressurized	Pressurized		

12.2 Piping System - Construction

12.2.1	Piping manufacturer	OPW	OPW		
12.2.2	Piping model	C20A	C20A		
12.2.3	Material of construction ⁴	DW Flex	DW Flex		
12.2.4	If Other (specify)	N/A	N/A		

12.3 Piping System - Interstitial Monitoring (Leak Detection) ⁵

12.3.1	Method of monitoring piping interstice ⁶	Liquid Detecting Sensor	Liquid Detecting Sensor		
12.3.2	Piping interstitial sensor manufacturer	Veeder-Root	Veeder-Root		
12.3.3	Piping interstitial sensor model	794380-208	794380-208		
12.3.4	Indicate if piping interstitial sensor is N=new or E=existing	New	New		

12.4 Piping System - Automatic Line Leak Detector (To Be Filled Out for Pressurized Piping Only)

12.4.1	Automatic Line Leak Detector (ALLD) (Mechanical or Electronic)	Electronic	Electronic		
12.4.2	ALLD manufacturer	Veeder-Root	Veeder Root		
12.4.3	ALLD model	859080-001	859080-001		
12.4.4	Indicate if ALLD is N=new or E=existing	New	New		

¹ Indicate which tank the piping is associated with (e.g., Tank 1, Tank 2A, Tank 2B). If the piping is associated with two or more USTs (e.g., a siphon manifold), then list both tanks in the column (e.g., Tank 1 & 2). If there is more than a single kind of piping associated with an individual tank, list each kind of piping in a separate column.

² If "existing", provide (minimally) the use, type of piping and configuration and as much other information as available.

³ Enter one of the following choices:
 PD = Product Distribution
 M = Tank Manifold (Siphon Bar)
 RF = Remote Fill
 PR = Product Return
 OTH = Other (specify)

⁴ Enter one of the following choices:

DW Flex = Double-walled Flex Piping (e.g., APT XP, APT UPP, OPW FlexWorks)
 DW FRP = Double-walled Fiberglass Reinforced Plastic (e.g., NOV Fiberglass Dualoy 3000/L (3" over 2"), Dualoy 3000/LCX, Red Thread IIA)
 DW Metal/Plastic = Double-walled Plastic secondary and metal primary (e.g., OmegaFlex DoubleTrac)
 None
 OTH = Other (specify)

⁵ All piping installed on or after November 1, 2007 must be of double-walled construction with continuous interstitial monitoring

⁶ Enter one of the following choices:

LDS = Liquid Detecting Sensor (e.g., sump sensor)
 VM = Vacuum Sensor
 PR = Pressure Sensor
 HYDRO = Hydrostatic Float
 OTH = Other (specify)

Note that discriminating sensors must be set up to detect and alarm with all liquids

UST-6

Application to Install or Replace Underground Storage Tank Systems (Pre/Post-Installation)



12. Description of All Piping Systems at this Facility (cont)

Instructions: Please complete Part 1 of this Section when submitting a UST-6A (proposed installation). Upon completion of installation, verify the information in Part 1 and revise as necessary, making sure to indicate those changes, and then complete Part 2. If there will be piping associated with more than four USTs, more than four different types of piping installed, etc., please attach additional copies of this page.

PART 1 - PRE-INSTALLATION (cont)

12.5 Piping System Information - Associated Piping Components

12.5.1	Tank # (associated with piping)	Tank No. 1 (gasoline)	Tank No. 2 (diesel)		
12.5.2	Method that will be used to allow piping to be located once it is backfilled? ¹	Detectable Tape	Detectable Tape		
12.5.3	If Other (specify)	N/A	N/A		

PART 2 - POST-INSTALLATION

12.6 Piping System - Post Installation Certification (To Be Filled Out After Installation is Complete)

12.6.1	Date of piping installation ²				
--------	--	--	--	--	--

¹ If detectable tape/wire is proposed, also list manufacturer/model number on UST-6C; tape/wire width (gauge) & installation depth on UST-6C or plans. Note that NC DEQ may require documentation that the pipe can be located after installation for compliance with 15A NCAC 02N.0904(d).

² For consistency, please use the same installation date as recorded on the piping manufacturer's installation checklists.

13. Description of Spill Prevention Equipment at this Facility

Please complete Part 1 of this Section when submitting a UST-6A (proposed installation). Upon completion of installation, verify the information in Part 1, revise as necessary.

PART 1 - PRE-INSTALLATION

13.1 Spill Prevention Equipment - General

13.1.1	Tank # (associated with)	Tank No. 1 (gasoline)	Tank No. 2 (diesel)		
13.1.2	Indicate if spill prevention equipment is N=new or E=existing ¹	New	New		

13.2 Spill Prevention Equipment - Construction

13.2.1	Spill prevention equipment type ²	DW	DW		
13.2.2	Spill prevention equipment manufacturer	OPW	OPW		
13.2.3	Spill prevention equipment model	1C-3132D	1C-3132 D		

13.3 Spill Prevention Equipment - Interstitial Monitoring Information ³

13.3.1	Method of monitoring interstice ⁴	Liquid Detecting Sensor	Liquid Detecting Sensor		
13.3.2	Does spill prevention equipment have built-in sensor?	<input checked="" type="checkbox"/> Yes <input type="checkbox"/> No	<input checked="" type="checkbox"/> Yes <input type="checkbox"/> No	<input type="checkbox"/> Yes <input type="checkbox"/> No	<input type="checkbox"/> Yes <input type="checkbox"/> No
13.3.3	Interstitial sensor manufacturer (if not built-in)	N/A	N/A		
13.3.4	Interstitial sensor model (if not built-in)	N/A	N/A		

¹ If "existing", fill out Section 13.1 at a minimum

² Enter one of the following choices:
 DW = Double-walled spill bucket
 SW+MCS = Single-walled spill bucket within a monitored containment sump
 SW = Single-walled spill bucket (only valid if installed prior to November 1, 2007)
 NR = Not Required (only valid for USTs that are always filled by transfers that are 25 gallons or less)

³ All spill prevention equipment installed on or after November 1, 2007 must be of double-walled construction with continuous interstitial monitoring (if tank installed on or after 11/1/2007) or mechanical float gauge (if tank installed prior to 11/1/2007).

⁴ Enter one of the following choices:

LDS = Liquid Detecting Sensor (e.g., sump sensor, float switch, etc.)
 VM = Vacuum Sensor
 PR = Pressure Sensor
 HYDRO = Hydrostatic Float
 MECH = Mechanical Float (only valid for tanks installed prior to 11/1/2007)
 OTH = Other (specify type)

Note: Discriminating sensors must be set up to detect and alarm with all liquids

UST-6

Application to Install or Replace Underground Storage Tank Systems (Pre/Post-Installation)



14. Description of All Containment Sumps at this Facility

Please complete Part 1 of this Section when submitting a UST-6A (proposed installation). Upon completion of installation, verify the information in Part 1, revise as necessary.

PART 1 - PRE-INSTALLATION

Enter the type and number(s) in each column that will have the same make/model of containment sumps. If all containment sumps will be the same, then list the range of sump numbers in one column. Containment sumps with the same make/model only have to be entered in one of the columns with a list of the sumps that have that make/model. For example, a gas station with three tank top containment sumps of the same make and model and four under dispenser containment (UDC) sumps of the same make and model could be grouped as Tank 1-3 and Disp. 1/2 - 7/8, respectively.

14.1 Containment Sumps - General					
14.1.1	Containment sump identifier / name (e.g., Disp. 1/2 - 7/8, Tank 1-3, etc.)	Tank No. 1 (gasoline)	Tank No. 2 (diesel)		
14.1.2	Quantity of containment sumps of this type	1	1		
14.1.3	Containment sump type ¹	Tank Top Sump	Tank Top Sump		
14.1.4	If Other (specify)	N/A	N/A		
14.1.5	Indicate if containment sump is N=new or E=existing ²	New	New		
14.2 Containment Sumps - Construction					
14.2.1	Containment sump manufacturer	OPW	OPW		
14.2.2	Containment sump model	FCSM-1-4233CR	FCSM-1-4233CR		
14.2.3	Material of construction ³	FRP	FRP		
14.2.4	If Other (specify)	N/A	N/A		
14.3 Containment Sumps - Leak Detection ⁴					
14.3.1	Method of monitoring containment sump ⁵	Liquid Detecting Sensor	Liquid Detecting Sensor		
14.3.2	Interstitial sensor manufacturer	Veeder-Root	Veeder-Root		
14.3.3	Interstitial sensor model	794380-208	794380-208		
14.3.4	Indicate if interstitial sensor is N=new or E=existing	New	New		

¹ Enter one of the following choices:
 TTS = Tank Top Sump (e.g., STP sump)
 UDC = Under Dispenser Containment Sump
 TS = Transition Sump
 OTH = Other (specify)

² Note that existing containment sumps, when connected to replacement piping, will require continuous monitoring and must be tested for integrity

³ Enter one of the following choices:
 PLS = Plastic
 FRP = Fiberglass Reinforced Plastic
 OTH = Other (specify)

⁴ All single-walled or metal UST system components (e.g., flex connectors, automatic line leak detectors, submersible turbine pumps, shear valves) installed on or after November 1, 2007 must be located within continuously monitored containment sumps

⁵ Enter one of the following choices:
 LDS = Liquid Detecting Sensor (e.g., sump sensor)
 VM = Vacuum Sensor
 PR = Pressure Sensor
 HYDRO = Hydrostatic Float
 OTH = Other (specify)

Note that discriminating sensors must be set up to detect and alarm with all liquids

UST-6

Application to Install or Replace Underground Storage Tank Systems (Pre/Post-Installation)



14. Description of All Containment Sumps at this Facility

Please complete Part 1 of this Section when submitting a UST-6A (proposed installation). Upon completion of installation, verify the information in Part 1, revise as necessary.

PART 1 - PRE-INSTALLATION

Enter the type and number(s) in each column that will have the same make/model of containment sumps. If all containment sumps will be the same, then list the range of sump numbers in one column. Containment sumps with the same make/model only have to be entered in one of the columns with a list of the sumps that have that make/model. For example, a gas station with three tank top containment sumps of the same make and model and four under dispenser containment (UDC) sumps of the same make and model could be grouped as Tank 1-3 and Disp. 1/2 - 7/8, respectively.

14.1 Containment Sumps - General					
14.1.1	Containment sump identifier / name (e.g., Disp. 1/2 - 7/8, Tank 1-3, etc.)	Transition Sump No. 1	Transition Sump No. 2		
14.1.2	Quantity of containment sumps of this type	1	1		
14.1.3	Containment sump type ¹	Transition Sump	Transition Sump		
14.1.4	If Other (specify)	N/A	N/A		
14.1.5	Indicate if containment sump is N=new or E=existing ²	Existing	Existing		
14.2 Containment Sumps - Construction					
14.2.1	Containment sump manufacturer	OPW	OPW		
14.2.2	Containment sump model	PTS-4021	PTS-4021		
14.2.3	Material of construction ³	Plastic	Plastic		
14.2.4	If Other (specify)	N/A	N/A		
14.3 Containment Sumps - Leak Detection ⁴					
14.3.1	Method of monitoring containment sump ⁵	Liquid Detecting Sensor	Liquid Detecting Sensor		
14.3.2	Interstitial sensor manufacturer	Veeder-Root	Veeder-Root		
14.3.3	Interstitial sensor model	794380-208	794380-208		
14.3.4	Indicate if interstitial sensor is N=new or E=existing	Existing	Existing		

¹ Enter one of the following choices:
 TTS = Tank Top Sump (e.g., STP sump)
 UDC = Under Dispenser Containment Sump
 TS = Transition Sump
 OTH = Other (specify)

² Note that existing containment sumps, when connected to replacement piping, will require continuous monitoring and must be tested for integrity

³ Enter one of the following choices:
 PLS = Plastic
 FRP = Fiberglass Reinforced Plastic
 OTH = Other (specify)

⁴ All single-walled or metal UST system components (e.g., flex connectors, automatic line leak detectors, submersible turbine pumps, shear valves) installed on or after November 1, 2007 must be located within continuously monitored containment sumps

⁵ Enter one of the following choices:
 LDS = Liquid Detecting Sensor (e.g., sump sensor)
 VM = Vacuum Sensor
 PR = Pressure Sensor
 HYDRO = Hydrostatic Float
 OTH = Other (specify)

Note that discriminating sensors must be set up to detect and alarm with all liquids

UST-6

Application to Install or Replace Underground Storage Tank Systems (Pre/Post-Installation)



14. Description of All Containment Sumps at this Facility

Please complete Part 1 of this Section when submitting a UST-6A (proposed installation). Upon completion of installation, verify the information in Part 1, revise as necessary.

PART 1 - PRE-INSTALLATION

Enter the type and number(s) in each column that will have the same make/model of containment sumps. If all containment sumps will be the same, then list the range of sump numbers in one column. Containment sumps with the same make/model only have to be entered in one of the columns with a list of the sumps that have that make/model. For example, a gas station with three tank top containment sumps of the same make and model and four under dispenser containment (UDC) sumps of the same make and model could be grouped as Tank 1-3 and Disp. 1/2 - 7/8, respectively.

14.1 Containment Sumps - General

14.1.1	Containment sump identifier / name (e.g., Disp. 1/2 - 7/8, Tank 1-3, etc.)	Dispensers 1/2 & 5/6	Dispensers 3/4 & 7/8		
14.1.2	Quantity of containment sumps of this type	2	2		
14.1.3	Containment sump type ¹	UDC Sump	UDC Sump		
14.1.4	If Other (specify)	N/A	N/A		
14.1.5	Indicate if containment sump is N=new or E=existing ²	Existing	Existing		

14.2 Containment Sumps - Construction

14.2.1	Containment sump manufacturer	OPW	OPW		
14.2.2	Containment sump model	DS-1123	DS-1123		
14.2.3	Material of construction ³	Plastic	Plastic		
14.2.4	If Other (specify)	N/A	N/A		

14.3 Containment Sumps - Leak Detection ⁴

14.3.1	Method of monitoring containment sump ⁵	Liquid Detecting Sensor	Liquid Detecting Sensor		
14.3.2	Interstitial sensor manufacturer	Veeder-Root	Veeder-Root		
14.3.3	Interstitial sensor model	794380-208	294380-208		
14.3.4	Indicate if interstitial sensor is N=new or E=existing	Existing	Existing		

¹ Enter one of the following choices:

- TTS = Tank Top Sump (e.g., STP sump)
- UDC = Under Dispenser Containment Sump
- TS = Transition Sump
- OTH = Other (specify)

² Note that existing containment sumps, when connected to replacement piping, will require continuous monitoring and must be tested for integrity

³ Enter one of the following choices:

- PLS = Plastic
- FRP = Fiberglass Reinforced Plastic
- OTH = Other (specify)

⁴ All single-walled or metal UST system components (e.g., flex connectors, automatic line leak detectors, submersible turbine pumps, shear valves) installed on or after November 1, 2007 must be located within continuously monitored containment sumps

⁵ Enter one of the following choices:

- LDS = Liquid Detecting Sensor (e.g., sump sensor)
- VM = Vacuum Sensor
- PR = Pressure Sensor
- HYDRO = Hydrostatic Float
- OTH = Other (specify)

Note that discriminating sensors must be set up to detect and alarm with all liquids

UST-6

**Application to Install or Replace Underground Storage Tank Systems
(Pre/Post-Installation)**



15. Description of Overfill Prevention Equipment at this Facility

Please complete Part 1 of this Section when submitting a UST-6A (proposed installation). Upon completion of installation, verify the information in Part 1, revise as necessary.

PART 1 - PRE-INSTALLATION

15.1 Overfill Prevention Equipment - General

15.1.1	Tank # (associated with)	Tank No. 1 (gasoline)	Tank No. 2 (diesel)		
15.1.2	Overfill prevention equipment type ¹	Automatic Shutoff	Automatic Shutoff		
15.1.3	Indicate if overfill prevention equipment is N=new or E=existing ²	New	New		
15.2 Overfill Prevention Equipment - Construction					
15.2.1	Overfill prevention equipment manufacturer	OPW	OPW		
15.2.2	Overfill prevention equipment model	71SOM-412C	71SO-410CB		

16. Description of Leak Detection Monitoring Equipment at this Facility

Please complete Part 1 of this Section when submitting a UST-6A (proposed installation) application. Upon completion of installation, verify the information in Part 1, revise as necessary.

PART 1 - PRE-INSTALLATION

Please list the manufacturer and model of each leak detection monitoring console that is being used at the UST facility. If more than one monitoring console is being used, list each monitoring console and specify which tanks, piping, containment sumps, etc. are being monitored by each.

16.1 Leak Detection Monitoring Equipment - General

		Monitoring Console #1	Monitoring Console #2	Monitoring Console #3	Monitoring Console #4
16.1.1	Monitoring console manufacturer	Veeder-Root			
16.1.2	Monitoring console model	TLS-450			
16.1.3	Indicate if N=new or E=existing Equipment	Existing			

17. Description of Stage I Vapor Recovery Equipment at this Facility

Note: the following gasoline USTs are not required to have Stage I vapor recovery equipment: a) new USTs that are 500 gallons or less in capacity, and b) facilities that have a combined throughput of less than 50,000 gallons per year. If vapor recovery is not required for a UST at this facility, then the last box in this section should be marked. If you have any questions about Stage I vapor recovery, please call the Air Quality Section at (919) 707-8400.

17.1.1	Tank # (associated with)	Tank No. 1 (gasoline)	Tank No. 2 (diesel)		
17.1.2	Indicate if N=new or E=existing Equipment	New	New		
17.1.3	Type of Stage I vapor recovery	<input type="checkbox"/> Coaxial system <input checked="" type="checkbox"/> Dual point system <input type="checkbox"/> Stage 1 vapor recovery is not required for this UST	<input type="checkbox"/> Coaxial system <input checked="" type="checkbox"/> Dual point system <input type="checkbox"/> Stage 1 vapor recovery is not required for this UST	<input type="checkbox"/> Coaxial system <input type="checkbox"/> Dual point system <input type="checkbox"/> Stage 1 vapor recovery is not required for this UST	<input type="checkbox"/> Coaxial system <input type="checkbox"/> Dual point system <input type="checkbox"/> Stage 1 vapor recovery is not required for this UST

¹ Enter one of the following choices:

AS = Automatic shutoff device (e.g., flapper valve)

BF = Ball float vent valve (e.g., vent restriction device) [Note: Ball Floats cannot be used with coaxial vapor recovery or suction piping systems. Also, new ball floats cannot be installed after June 1, 2017]

OA = Overfill alarm [Note: Alarm must be located where fuel delivery takes place.]

NR = Not required [Note: Not Required is only valid for USTs that are always filled by transfers that are 25 gallons or less.]

[Note: If installing an automatic shut off device (e.g., flapper valve) and a ball float vent valve on the same tank, the ball float must be set to activate at a level higher in the tank than the automatic shut-off device. Only show the primary overfill prevention device in this section.]

² If "existing", provide (minimally) the type of equipment and as much other information as available.

UST-6

**Application to Install or Replace Underground Storage Tank Systems
(Pre/Post-Installation)**



Please complete this page when submitting a UST-6B (post-installation).

18. Certification of Installation (Must be completed by UST system installer)

Were there any modifications to the approved UST-6A application? Yes No

If "Yes" then briefly describe below or attach separate description of the modifications (Note: Professional Engineer must approve and seal any changes to the UST-6C and original design plans):

OATH: I certify, under penalty of law, that the information provided in this application is accurate and true to the best of my belief and knowledge and that the UST system equipment was installed in accordance with the UST system design plans, the manufacturer's guidelines and the applicable national codes of practice and industry standards listed in 15A NCAC 02N .0900.

Installer:

Print Name _____

Job Title _____

Signature _____

Date _____

Penalties: Pursuant to N.C.G.S.143-215.94W any person who knowingly fails to notify or submits false information shall be subject to a civil penalty not to exceed \$10,000 per day, per violation.

19. Facility Owner Certification and Acknowledgement (Read and Sign After Completing Sections 1 to 7 and 12 to 21)

I certify, under penalty of law, that I have personally examined and am familiar with the information submitted in this and all attached documents; and that based on my inquiry of those individuals responsible for obtaining this information, I believe that the submitted information is true, accurate, and complete. In addition, I certify that all applicable State and Federal UST requirements have been complied with.

Print Name of UST Facility Owner or Authorized Representative _____

Print Title of Owner or Authorized Representative _____

Signature _____

Date _____

Penalties: Pursuant to N.C.G.S.143-215.94W any person who knowingly fails to notify or submits false information shall be subject to a civil penalty not to exceed \$10,000 per day, per violation.

UST-6

Application to Install or Replace Underground Storage Tank Systems (Pre/Post-Installation)



Please complete this page when submitting a UST-6B (post-installation).

20. UST-6B Attachments (Post-Installation)

Please attach the following items to this submittal (i.e., Pages 1, 8 and 9).

20.1	Sections 11 through 17 (pages 3-7) of the UST-6 form detailing the completed installation, indicating any changes that were made to the originally approved plans	<input type="checkbox"/> Yes	
20.2	Proof of Financial Responsibility along with the Certification of Financial Responsibility form ¹	<input type="checkbox"/> Yes	<input type="checkbox"/> Previously submitted
20.3	Manufacturers tank installation checklist and warranty registrations.	<input type="checkbox"/> Yes	<input type="checkbox"/> N/A, for piping only
20.4	Manufacturers piping installation checklist and warranty registrations.	<input type="checkbox"/> Yes	<input type="checkbox"/> N/A, for tank only
20.5	Copies of manufacturer's installer certifications for each employee who installed equipment at this facility.	<input type="checkbox"/> Yes	
20.6	One copy of 11" x 17" as-built plans signed/sealed by a NC PE documenting and detailing the completed installation, indicating any changes that were made to the originally approved design plans. [Note: If no changes were made, no as-builts need to be submitted.]	<input type="checkbox"/> Yes	<input type="checkbox"/> N/A. The originally approved engineered design plans can be used as as-builts, as there were no changes.
20.7	UST-6C, "Application to Install or Replace Underground Storage Tank Systems (Schedule of Materials)" attached. [Note: If no changes were made, no UST-6C needs to be submitted.]	<input type="checkbox"/> Yes	<input type="checkbox"/> N/A. The originally approved UST-6C can be used, as there were no changes.
20.8	UST-6D/23A "Application to Install or Replace Underground Storage Tank Systems (Spill Bucket Installation Testing)" containing post-installation test results ¹ .	<input type="checkbox"/> Yes	<input type="checkbox"/> N/A
20.9	UST-6E/23D "Application to Install or Replace Underground Storage Tank Systems (Tank Installation Testing)" containing pre-installation and post-installation test results ¹ .	<input type="checkbox"/> Yes	<input type="checkbox"/> N/A, for piping only
20.10	UST-6F/23B "Application to Install or Replace Underground Storage Tank Systems (UDC/Containment Sump Installation Testing)" containing post-installation test results ¹ .	<input type="checkbox"/> Yes	<input type="checkbox"/> N/A
20.11	UST-6H/23C "Application to Install or Replace Underground Storage Tank Systems (Piping Post-Installation Testing)" containing post-installation test results ¹	<input type="checkbox"/> Yes	<input type="checkbox"/> N/A
20.12	Line Tightness Test (LTT) results and data sheets ¹ .	<input type="checkbox"/> Yes	<input type="checkbox"/> N/A
20.13	Automatic Line Leak Detector (ALLD) test results and data sheets ¹ .	<input type="checkbox"/> Yes	<input type="checkbox"/> N/A, non-pressurized piping only
20.14	UST-22A, "Overfill Prevention Equipment Operability Check" ¹ .	<input type="checkbox"/> Yes	<input type="checkbox"/> N/A
20.15	UST-22B, "Annual Leak Detection Equipment Operability Check" ¹ .	<input type="checkbox"/> Yes	<input type="checkbox"/> N/A
20.16	UST-22C, "Annual Sump Visual Inspections" ¹ .	<input type="checkbox"/> Yes	<input type="checkbox"/> N/A
20.17	Leak detection console printout documenting the setup of each interstitial sensor (e.g., vacuum, pressure, hydrostatic, liquid-detecting sensor). Please submit results copied onto 8.5 X 11 paper.	<input type="checkbox"/> Yes	
20.18	Leak detection console printout documenting the functionality of each interstitial sensor (e.g., vacuum, pressure, hydrostatic, liquid-detecting sensor). The sensor functionality tests, conducted in accordance with manufacturer's written guidelines, should consist of printouts documenting the status of each sensor: <ul style="list-style-type: none"> • Normal / OK Status (Prior to Test) • Alarm (During Test) • Normal / OK Status (At the Conclusion of the Test) Note: Additional printouts may be required to document sensors with multiple alarm states (e.g., discriminating sensors, position-sensitive sensors, dual-float hydrostatic sensors). Please submit results copied onto 8.5 X 11 paper ¹ .	<input type="checkbox"/> Yes	<input type="checkbox"/> N/A

¹ At a minimum, items that need to be completed for a Temporary Operating Permit (TOP) to be issued. TOP will be valid for a period of approximately 60 days to allow interim operations while the other application items are completed.

UST-6C

Application to Install or Replace Underground Storage Tank Systems (SCHEDULE OF MATERIALS)



Facility ID No.	Facility Name Fayetteville Public Works Commission	Attachment to (check one): UST-6A <input checked="" type="checkbox"/> UST-6B <input type="checkbox"/>
UST System components installed (Check one): <input checked="" type="checkbox"/> Tanks and Piping <input type="checkbox"/> Tanks Only <input type="checkbox"/> Piping Only		If attached to UST-6B, have any modifications been made to approved design plan? YES <input type="checkbox"/> NO <input type="checkbox"/>

INSTRUCTIONS: List the manufacturer, model or part number and quantity for the following equipment installed at the facility: tanks; piping including flexible connectors; leak detection equipment including the monitoring console, interstitial monitoring sensors and automatic line leak detectors; spill and overflow prevention equipment; vapor recovery equipment; containment sumps and method of locating the piping once it is buried. Group like categories of equipment together in the list. The item number provided below must correspond to the location(s) of the equipment shown on the scale drawing. Attach additional pages as necessary.

ITEM NO.	ITEM/PART DESCRIPTION	MANUFACTURER	MODEL/PART NO.	QTY
1	DW Steel / Polyurethane Tank; 20K	Highland Tank Company	Highguard	2
2	Vent Piping; 2-inch	Fiber Glass Systems	Red Thread IIA	86
3	Product Piping; 2-inch	OPW	Flexworks C20A	45
4	Double Wall Coupling; Stainless Steel	OPW	Flexworks DPC-2200A	4
5	Access Piping; 4-inch	OPW	Flexworks ACP40	45
6	Detectable Warning Tape	Seton	Style 85498	150
7	Interstitial Manhole	OPW	104A-1200WT	2
8	Interstitial Sensor	Veeder-Root	794380-333	2
9	Interstitial Riser Cap	Veeder-Root	312020-928	2
10	Double Wall Spill Container (fill)	OPW	1C-3132D	2
11A	Overfill Prevention Valve (gasoline)	OPW	71SOM-412C	1
11B	Overfill Prevention Valve (diesel)	OPW	71SO-410CB	1
12	Fill Adapter	OPW	633T-8075	2
13	Fill Adapter Lock Clamp	OPW	633LC-1000	4
14	Fill Cap	OPW	634TT-785-EVR	2
15	Single Wall Spill Container	OPW	1C-3101D	2
16	Extractor Fitting (vapor)	OPW	233-4420	2
17	Vapor Recovery Adapter	OPW	61VSA-1020-EVR	2
18	Vapor Recovery Cap	OPW	1711T-7085-EVR	2
19	Tank Sump	OPW	FCSB-1-4233CR	2
20	Manhole (tank sump)	OPW	42MAT-PL12	2
21A	Fuel Level Probe (gasoline)	Veeder-Root	846396-110/846400-100	1
21B	Fuel Level Probe (diesel)	Veeder-Root	846396-110/846400-101	1
22	Submerged Turbine Pump (STP)	Veeder-Root	AGP150S1 RJ2	2
23	Flexible Connector; Stainless Steel	OPW	FC20-MM12	2
24	Full Port Ball Valve	OPW	21BV-0200	2
25	Digital Pressure Line Leak Detector	Veeder-Root	859080-001	2

<p>Douglas N. Haggett _____ Print Name of North Carolina Professional Engineer</p> <p>Haggett Engineering Associates, Inc. _____ Company Name</p> <p>November 2, 2022 _____ Date</p>	<p>Affix PE seal here:</p>
--	----------------------------

APPENDIX C – SALE TAX FORMS

PROJECT TITLE AST SYSTEM CONVERSION TO UST SYSTEM **Pay App #** _____

SALES/USE TAX CERTIFICATE

(Use as many sheets as needed/sign affidavit of last sheet per pay estimate)

Analysis of consumed material **Manufactured or Purchased** by you. Sales and/or Use Tax Regulation Number 41 requires that the City of Fayetteville secure from each contractor certified statements setting forth the cost of the materials and supplies manufactured or purchased by you and consumed in construction. This form is provided for you to list the materials consumed in construction. Please complete this form by inserting the information required below.

<u>Vendor Name</u>	<u>Date Purchased</u>	<u>Invoice Number</u>	<u>Amount Less Tax</u>	<u>Sales Tax % State/ % Local</u>	<u>Invoice Total</u>	<u>County Paid</u>
_____	_____	_____	_____	_____/_____	_____	_____
_____	_____	_____	_____	_____/_____	_____	_____
_____	_____	_____	_____	_____/_____	_____	_____
_____	_____	_____	_____	_____/_____	_____	_____
_____	_____	_____	_____	_____/_____	_____	_____
_____	_____	_____	_____	_____/_____	_____	_____

\$ _____ \$ _____ \$ _____ \$ _____

AFFIDAVIT

This is to certify that sales/use tax was or will be paid as stated above on materials and supplies purchased or manufactured by the **City of Fayetteville, North Carolina**, for the above mentioned project during the period and billed on this payment application # _____

(Contractor)

(Authorized Signature/Date)

(Address)

(Telephone Number)

(City, State, Zip)

(Fax Number)

Date: _____

Page _____ **of** _____