



**INVITATION FOR BID**

**PWC2324039-REBID**

**CUMBERLAND RD. SUBSTATION  
STRUCTURE AND EQUIPMENT**

**Date of Issue: January 30, 2024  
Date of Opening: February 15, 2024  
1:00 p.m.**

**Direct all inquiries concerning this IFB to:**

**Victoria McAllister  
Procurement Manager  
[procurement@faypwc.com](mailto:procurement@faypwc.com)**

**Contents**

**ADVERTISEMENT FOR BID** ..... 3

**INSTRUCTIONS TO BIDDERS** ..... 4

**PURPOSE AND BACKGROUND** ..... 4

**OBJECTIVE OF THE REQUEST** ..... 4

**IFB SCHEDULE** ..... 4

**QUESTIONS** ..... 4

**MINORITY, WOMEN, AND DISADVANTAGED BUSINESS ENTERPRISE (MWDBE) PROGRAM / SMALL LOCAL SUPPLIER (SLS) PROGRAM** ..... 5

**REFERENCES** ..... 6

**SUBMISSION INSTRUCTIONS** ..... 6

**QUANTITIES AND PRICING** ..... 7

**EVALUATION AND AWARD** ..... 7

**DELIVERY AND PAYMENT** ..... 8

**ATTACHMENT A: TECHNICAL SPECIFICATIONS & DRAWINGS** ..... 9

**ATTACHMENT B: BID PRICING FORM** ..... 10

**ATTACHMENT C: CERTIFICATION OF PRIMARY PARTICIPANT REGARDING DEBARMENT, SUSPENSION AND OTHER RESPONSIBILITY MATTERS** ..... 11

**ATTACHMENT D: AT A GLANCE** ..... 12

**ATTACHMENT E: PWC SALE OF GOOD AGREEMENT** ..... 13

**ATTACHMENT F: MWDBE AFFIDAVITS** ..... 14

**ATTACHMENT G: SMALL LOCAL SUPPLIER/MWDBE SUBCONTRACTOR DISCLOSURE FORM** ..... 15

**ADVERTISEMENT FOR BID  
FAYETTEVILLE PUBLIC WORKS COMMISSION  
CUMBERLAND RD. STRUCTURE AND EQUIPMENT**

**Cumberland County  
North Carolina**

Bids are solicited and will be received at Fayetteville Public Works Commission, Administration Building, Conference Room 107, 955 Old Wilmington Road, Fayetteville, NC 28301, until **1:00 p.m., EST Thursday, February 15, 2024**, for the **CUMBERLAND RD. STRUCTURE AND EQUIPMENT**.

Enclosed please find the Instructions to Bidders, Detailed Specifications, and Bid Pricing Form. Bids shall be submitted on the forms provided herein, or exact copies thereof, and the bidder shall return one copy of the entire bid packet along with the completed Bid Pricing Form and any other information specified in the bid documents.

Questions regarding this bid must be submitted in writing to the attention of Victoria McAllister, Procurement Manager at [procurement@faypwc.com](mailto:procurement@faypwc.com) no later than **Tuesday, February 6, 2024 at 5:00 p.m. E.T.**, in order to be considered for a response.

Mailed bids must be addressed to **Victoria McAllister**, Procurement Manager, Fayetteville Public Works Commission, 955 Old Wilmington Road, Fayetteville, North Carolina 28301. The outside of the envelope must be marked **BID: PWC2324039- REBID-CUMBERLAND RD. SUBSTATION STRUCTURE AND EQUIPMENT** and shall indicate the name, and address of the bidder. No electronic submissions will be accepted.

Fayetteville Public Works Commission reserves the right to reject any or all bids for any reason determined by PWC to be in its best interest, or to award the bid to the lowest responsible bidder or bidders, taking into consideration quality, performance, and the time specified in the bids for the performance of the contract.

**FAYETTEVILLE PUBLIC WORKS COMMISSION**  
Victoria McAllister  
Procurement Manager

**INSTRUCTIONS TO BIDDERS  
FAYETTEVILLE PUBLIC WORKS COMMISSION  
CUMBERLAND RD. SUBSTATION STRUCTURE AND EQUIPMENT**

**PURPOSE AND BACKGROUND**

Fayetteville Public Works Commission intends to solicit bids from qualified vendors to furnish and deliver all materials and equipment (except materials and equipment specified to be furnished by the Owner) complete and conforming to the specifications for the installation of the Cumberland Road 69 TO 15 x 25 kV Substation.

**OBJECTIVE OF THE REQUEST**

It is the intent of this bid invitation to obtain pricing for **CUMBERLAND RD. SUBSTATION STRUCTURE AND EQUIPMENT** within the detailed specifications section of this Invitation for Bid (IFB). You are requested to submit your bid on the enclosed Bid Pricing Form.

**IFB SCHEDULE**

The following table shows the schedule of events to prepare your organization’s response. The key deadlines and targeted dates for this process are as follows:

<b>Action</b>	<b>Responsibility</b>	<b>Date/Time</b>
Submit Written Questions	Bidders	Tuesday, February 6, 2024 by 5:00 P.M. ET
Provide Response to Questions	PWC	Thursday, February 8, 2024 by 5:00 P.M. ET.
Submit IFB	Bidders	Thursday February 15, 2024 by 1:00 P.M. ET
Target Commission Date	PWC	TBD
Target Council Date	PWC	TBD
Award /Sale of Goods Agreement	PWC	TBD

**QUESTIONS**

Written questions shall be e-mailed to [procurement@faypwc.com](mailto:procurement@faypwc.com) by the date and time specified in the IFB schedule. Bidders will enter “**IFB PWC2324039–REBID Questions**” as the subject of the email.

Questions received prior to the submission deadline date, the Procurement Manager’s response, and any additional information deemed necessary by PWC will be posted in the form of an addendum to the PWC website and shall become an Addendum to this IFB. No information, instruction, or advice provided orally or informally by any PWC personnel, whether made in response to a question or otherwise concerning this IFB, shall be considered authoritative or binding. Firms shall rely only on written material contained in an Addendum to this IFB.

Inquiries should be submitted no later than the date and time noted in the IFB schedule. Questions answered verbally will be followed up by written addenda as deemed necessary; oral

interpretations shall have no effect.

## **MINORITY, WOMEN, AND DISADVANTAGED BUSINESS ENTERPRISE (MWDBE) PROGRAM / SMALL LOCAL SUPPLIER (SLS) PROGRAM**

PWC is committed to promoting the utilization of Minority, Women, and Disadvantaged Businesses in PWC's geographical statistical area (GSA) by providing equal opportunity for participating in all aspects of PWC's contracting and procurement programs. The GSA consists of NCDOT division areas 3-8, and 10. PWC is also committed to promoting the utilization of small, local businesses in the Fayetteville Metropolitan Statistical Area (MSA) by increasing opportunities for those businesses to participate in PWC procurements. The MSA consists of Cumberland County, Hoke County, and Harnett County.

PWC requires Firms to report efforts to utilize Minority, Women, and Disadvantaged Business Enterprises (MWDBEs) and Historically Underutilized Businesses (HUBs) for specific projects and requires all Firms to report all such efforts for MWDBEs, HUBs, and Small Local Suppliers regardless of the requirements of a specific project. **Bidders shall document any good-faith efforts and utilization in the MWDBE forms provided within Attachment F.**

In accordance with PWC's MWDBE Program, the goal shall be to award four percent (4%) of the total contract dollars to MBE firms and four percent (4%) to WBE firms. A complete copy of PWC's MWDBE Program is available for inspection at PWC Procurement Department.

The following is a list of the efforts that should be made by the prime service provider to encourage MWDBE participation. In order to receive credit for having made "good faith efforts", the prime service provider should document all actions taken to include the following:

- 1) Attending pre-bid meetings scheduled by the department;
- 2) Identifying selected specific items of the project which could be executed by a MWDBE;
- 3) Soliciting MWDBE service provider participation in a reasonable time before the proposals are due through advertisements in circulation media, trade publications, and minority-focused media;
- 4) Contacting local firms, firms owned by minorities or women, and associations or business development centers which disseminate information to local businesses and businesses owned by minorities or women in a timely manner to allow sufficient time for MWDBEs to respond;
- 5) Following up on initial solicitations of interest by contacting the MWDBE to determine whether the MWDBE was interested in performing specific items of the project;
- 6) Attempting to enter into joint venture or partnership arrangements with MWDBEs and provide interested MWDBEs with information about the requirements for the project;
- 7) Providing assistance to MWDBEs in the review of proposals and work to be done by sub-service providers;

- 8) Using available directories of certified MWDBEs and other available resources;
- 9) Ensuring that the proposer negotiated in good faith with the MWDBE and did not unjustifiably reject as unsatisfactory quotes prepared by any Minority, Women, or Disadvantaged Business Enterprise;
- 10) Making every effort to obtain Minority, Women, or Disadvantaged Business Enterprise participation that could reasonably be expected to produce a level of participation sufficient to meet the goals of PWC; and
- 11) Providing interested minority, women, and disadvantaged businesses with information relative to project requirements

**REFERENCES**

Bidders shall provide at least three (3) different references for which your company has supplied the exact model of equipment offered. PWC may contact these references to determine the commodity provided are substantially similar in scope to those requested in Attachment A and that the bidder’s performance has been satisfactory. The information obtained shall be considered in the evaluation of the bid. If PWC is referenced, it cannot be counted towards your three (3) required references but may be included in addition to.

COMPANY NAME	CONTACT NAME	TELEPHONE NUMBER	EMAIL
Fayetteville Public Works Commission, if applicable			

**SUBMISSION INSTRUCTIONS**

- 1) Bids should be complete and carefully worded and should convey all the information requested in the IFB. Bids should be prepared simply and economically, providing a straightforward, concise description of the bidder’s capabilities to satisfy the requirements of the IFB. Emphasis should be on completeness and clarity of content. If the bid includes any comment over and above the specific information requested in the IFB, the bidder should include this information as a separate appendix to its bid. Bids that include clarifications or modifications to any of the IFB’s contractual requirements, or a bidder’s standard terms and conditions, may be deemed non-responsive and not considered for award at PWC’s discretion. Unsolicited bid samples or descriptive literature will not be examined or tested, will not be used to determine responsiveness, and will not be deemed to vary any of the provisions of the IFB. Failure to comply with these requirements shall constitute sufficient cause to reject a bid without further consideration. PWC reserves the right to accept or reject any bid and to annul the bidding process and reject all bids at any time prior to award of a Sale of Goods Agreement, without thereby incurring any liability to the affected bidder or bidders or any

obligation to inform the affected bidder or bidders the reasons for PWC's action.

- 2) Bids may be withdrawn by the bidder only in writing and if receipt of such withdrawal is acknowledged by PWC prior to the time for the bid submittal deadline identified in the Advertisement for Bidders (or such later date included in an Addendum). Written withdrawal requests shall be submitted on the bidder's letterhead and signed by an official of the bidder duly authorized to make such request. Any withdrawal request made after the bid submittal deadline shall be allowed only if the price bid was based upon a mistake that constituted a substantial error, provided the bid was submitted in good faith, and then only pursuant to the terms of N.C.G.S. § 143-129.1.
- 3) Bids submitted in an envelope must have the bid title, date, and time of the bid submittal deadline on the front of the envelope no later than the bid due date and time. The sealed bid will be due at the **Fayetteville Public Works Commission, Administration Building, Procurement Department, 955 Old Wilmington Road, Fayetteville, NC 28301**. No electronic submissions will be accepted.
- 4) Bids will be examined promptly after the due date and an award will be made at the earliest possible date. Bids must be held firm for PWC for a period of sixty (60) days after the bid due date. A purchase order will be issued to the awarded bidder.
- 5) Bidders shall submit bids only on the Bid Pricing Forms provided herein, or exact copies thereof (**See Exhibit B – Bid Pricing Form**). Failure to provide full and complete Bid Pricing Forms may result in a bid being deemed non-responsive.
- 6) All bids must be signed by an authorized official of the bidder. Bids may be rejected for any omission, alteration of form, additions not called for, conditional bid, or any irregularities of any kind.
- 7) Do not submit alternate bids unless specifically called for on the Bid Pricing Forms.

## **QUANTITIES AND PRICING**

- 1) Quantities listed are estimates ONLY based on historical usage. PWC does not guarantee a minimum or maximum quantity to be purchased.
- 2) All bidders are advised to include all costs incurred by the bidder in delivering the **CUMBERLAND RD. SUBSTATION STRUCTURE AND EQUIPMENT** to the PWC **CUMBERLAND RD. SUBSTATION 2336 CARBINE ST. FAYETTEVILLE, NC 28306** in their bid submittal. The invoice submitted for payment shall not reflect any other costs (fuel surcharge, toll, etc.).

## **EVALUATION AND AWARD**

- 1) An award of a contract is subject to the approval by the Board of Commissioners of PWC and the Fayetteville, North Carolina City Council.
- 2) PWC reserves the right to inspect, at a reasonable time, the equipment, item, plant, or other facilities of a prospective Bidder prior to award, and during the Sale of Goods Agreement term,

---

## **CUMBERLAND RD. SUBSTATION STRUCTURE AND EQUIPMENT**

as PWC deems necessary to determine that such equipment, item, plant, or other facilities conform with the specifications/requirements and are adequate and suitable for the proper and effective performance of the Sale of Goods Agreement.

- 3) PWC reserves the right to request additional information from bidders to aid in the evaluation process. This information may include but is not limited to, financial statements, a reference list of contracts of similar size, etc.
- 4) PWC reserves the right to make a single award for all items or may award separate contracts to multiple bidders for various items to the lowest responsive, responsible bidder or bidders, taking into consideration product quality, performance to PWC, and conformity with the specifications in these bid documents. PWC may also consider, among other things, the Bidder's past performance conduct on other contracts, and other information as PWC deems necessary to assist in the evaluation of any bid.
- 5) The Sale of Goods Agreement will be awarded for a one-time purchase to occur on or before June 30, 2024.

## **DELIVERY AND PAYMENT**

- 1) Delivery to be made F.O.B. Public Works Commission **2336 CARBINE ST. FAYETTEVILLE, NC 28306.**
- 2) Deliveries shall be made between the hours of **9:00 a.m. and 3:00 p.m., Monday through Friday**, within the time frame specified on the Bid Pricing Form.
- 3) Payment for equipment, material, supplies, etc. purchased pursuant to this bid shall be made by Public Works Commission approximately thirty days after the same has been delivered, inspected, approved and the invoice received in the PWC Accounts Payable Office, P.O. Box 1089, Fayetteville, North Carolina 28302.



**ATTACHMENT A: TECHNICAL SPECIFICATIONS & DRAWINGS**

# **TECHNICAL SPECIFICATIONS**

**PUBLIC WORKS COMMISSION  
FAYETTEVILLE, NORTH CAROLINA**

**STRUCTURES AND EQUIPMENT FOR  
CUMBERLAND ROAD SUBSTATION**

<b>TECHNICAL SPECIFICATIONS</b>
---------------------------------

**1.0 Scope**

Public Works Commission of Fayetteville, North Carolina, is procuring materials for the installation of the CUMBERLAND ROAD Substation. These Technical Specifications describe the structural materials, equipment, and the associated components for the installation of these facilities.

The Bidder's work shall include furnishing all equipment and materials so represented by the Bill of Materials, the accompanying Drawings, these Technical Specifications, and as set forth in the Bid Schedule. The Owner reserves the right to select any combination of alternate schedules as may be allowed. The Owner also reserves the right to reject any or all bids.

**The Bill of Materials supplied with these Specifications represents the type of materials to be supplied. The Bidder has the responsibility of furnishing the quantity, all mounting hardware, and miscellaneous other materials necessary for a complete and functional substation, except for items designated to be furnished by Owner.**

**2.0 General**

These Specifications describe the type, size, and characteristics of the various materials and equipment required to be furnished. The Drawings indicate general arrangement, equipment location, and spacing.

Strict adherence to these general Specifications and Drawings is requested to facilitate checking and consideration of the Proposal.

Proposals shall include the following:

- 2.1. Catalog numbers, manufacturer, ratings, characteristics, types, sizes, etc., of all materials and equipment included. A simple statement that all necessary materials and equipment will be provided is not satisfactory. A List of Materials is included at the end of these Specifications for providing this information.
- 2.2. Proposal for the substation shall include all materials and equipment required for a complete and coordinated substation. The Successful Bidder shall submit along with his quotation a complete list of materials to be furnished for the substation.
- 2.3. Prices shall include the cost of delivery to Fayetteville, North Carolina.
- 2.4. Coordinated shipment shall be made to reduce storage by Contractor and to facilitate the accumulation of component parts. Small piecemeal shipments will not be accepted. The number of shipments shall not exceed five (5) unless approved by the Owner. Direct-manufacturer, factory-drop shipments shall not be accepted.
- 2.5. All components in the steel package shall be distinctly marked or identified and shall be completely assembled before shipment, insofar as is practical. Each Bidder shall so state in his Proposal the manner in which trusses and columns will be shipped.
- 2.6. The Bidder shall furnish specification sheets (and installation manuals when required) for all switches, connectors, fittings, insulators, and lightning arresters not explicitly called out in the approved Bill of Materials. These specification sheets shall be provided with the approval drawings.

- 2.7. Any design work performed by the Bidder shall be sealed by a Professional Engineer registered in the State where the project is located.

### **3.0 Special Conditions**

3.1. Material Shipments

The structures, crates, pallets, boxes, packing lists, etc. shall be maintained and clearly marked to correspond appropriately with the correct project.

3.2. Defective Materials, Equipment, and Workmanship

All materials and equipment furnished hereunder shall be subject to the inspection, tests, and approval of Owner; and the Bidder shall furnish all information required concerning the nature or source of any materials and equipment and provide adequate facilities for testing and inspecting the materials and equipment at the plant of the Bidder.

The materials and equipment furnished hereunder shall become the property of Contractor when delivered at the point to which shipment is to be made; provided, however, that Contractor may reject any such materials and equipment as does not comply with the Specifications for materials and equipment and warranties of the Bidder and manufacturers. Recognition and subsequent rejection of any defective materials and equipment may occur either before or after incorporation of such materials and equipment into the facilities, provided such rejection is made within one (1) year of date of delivery of the materials and equipment. Upon any such rejection, the Bidder shall replace the rejected materials and equipment with materials and equipment complying with the Specifications for materials and equipment and warranties FOB open-top truck or open trailer at suitable destination as determined by Contractor. Contractor shall return the rejected materials FOB open-top truck or open trailer at the same destination. In the event of the failure of the Bidder to so replace rejected materials and equipment, Contractor may make such replacement; and the cost and expense thereof shall be paid by and be recoverable from the Bidder.

3.3. Miscellaneous

The Bidder shall hold harmless and indemnify the Owner, its agents, and employees from any and all claims, suits, and proceedings for infringement of any patent or patents covering materials and equipment purchased hereunder. The Bidder shall defend any suit or proceeding brought against Owner, its agents, or employees based upon a claim that the materials and equipment, or any part thereof, constitute an infringement of any patent; or if the Bidder shall fail to defend such suit or proceeding, Owner may do so and the Bidder shall make reimbursement for the expense of such litigation. If the materials and equipment, or any part thereof, are held to constitute infringement and the use thereof is enjoined, the Bidder shall, at its own expense, either procure for Owner the right to continue to use the materials and equipment, or such part thereof, or shall replace the materials and equipment, or such part thereof, with non-infringing materials and equipment.

### **4.0 Standards**

- 4.1. All equipment and materials covered by these Specifications shall be in accordance with the applicable provisions of the latest editions of the Standards of the ASTM, ANSI, NEMA, IEEE, OSHA, RUS, and latest revision of the NESC. Where a manufacturer's name and type of equipment is indicated in the Specifications, it is for clarity and the establishment of a standard and is restrictive unless use of an approved equal is specifically mentioned.

The Bidder may offer alternate pricing for equivalent items by other manufacturers. However, all base bids must explicitly comply with the designated materials specified herein. The Owner may elect to purchase alternates, as proposed by the Bidder. The alternate materials are subject to review and approval by the Owner.

The basic system ratings for the substations shall be as follows:

System High-Side Voltage	69,000 volts, three-phase wye, Basic Insulation Level shall be 350 kV, 60 Hertz.
System Low-Side Voltage	25 kV at 150 BIL, 60 Hertz operated at 25 kV
Transformer Capacity	One (1) substation class power transformer rated 67 to 26.18 x 13.09 kV, rated 20/26.7//33.3.0 MVA, ONAN/ ONAF/ ONAF (55°C).
Structural Design	Medium Loading District, plus allowance for 0.50 inches of ice and 90 mph. wind with 150 mph. gusts.
Primary Bus and Secondary Bus	Strength requirements to match weight of equipment, ice, and wind loadings.
Incoming Circuit	2,500 lbs. factored per 69 kV phase conductor design tension, 1,500 lbs. unfactored per static conductor, +/- 15° take-off angle in any direction
Outgoing Circuits	Underground
69 kV Power Circuit Breaker	48 volt dc and 120/240 volt ac single-phase
Transformer	48 volt dc and 120/240 volt ac single-phase
Bus & Feeder Circuit Breakers	48 volt dc and 120/240 volt ac single-phase
Protective Relaying Panels	48 volt dc and 120/240 volt ac single-phase

## 5.0 **Drawings and Documentation**

### 5.1 Conceptual Design

The work shall conform to the Booth & Associates, Inc. Drawings listed in the Appendices, all of which form a part of these Specifications.

### 5.2 Load Calculations

The Commission's Engineer will prepare calculated loading reactions.

### 5.3 Design and Fabrication Drawings

The Commission's Engineer will prepare all Shop Drawings and Bill of Materials.

### 5.4 Bus Cutting Schedule

The Bidder shall provide a bus cutting schedule to demonstrate the bus quantity and be used by the construction contractor.

## 6.0 **Structural Steel**

6.1. The substation structures to be included in the Form of Proposal shall conform to the following specifications and are identified on the appropriate substation project drawing.

The Substation Structures are to include:

- 1) 69 kV, 4-inch diameter IPS aluminum bus and bus supports
- 2) 69 kV line A-frame terminating structure with 69 kV group-operated disconnect switches
- 3) Two (2) 69 kV group-operated switch structures
- 4) 85-foot direct embedded steel static masts, (one (1) required)
- 5) 25 kV, 6-bay underground feeder distribution structure

6.2. Specifications for the fabrication, erection and shipping of structural steel can be found in the Appendices of this specification.

## 7.0 Lightning Protection Structures

- 7.1. Lightning masts shall be one-inch diameter galvanized steel pipe capped at top end, of required length, and shall extend a minimum of ten feet (10') above the structure as shown on the Drawings. Lightning masts shall be supplied with mounting provisions for attachment to the steel columns of the substation structures. Lightning mast ground clamps shall be included for attachment of 2/0 AWG copper-clad steel leads as defined in **Section 12.0 Connectors**.
- 7.2. One (1) hot-dip galvanized steel pole shall be provided by the Bidder for primary bus static protection. The static pole shall be two-piece units, and shall be 85'-0" in length (for 10'-0" embedment), furnished complete with 10'-0" static rod designed for top mast mounting, for a total height of eighty-five feet (85') above-grade. The poles shall be equipped with Aeolian vibration suppression, service hand-hole, below-grade cable entrance slot, NEMA 2-hole pads for grounding, and two (2) floodlight brackets, as indicated on the Drawing details. The Bidder shall provide all mounting hardware, conductor, and connectors to complete assembly of the static masts per the Detail Drawings.

## 8.0 Miscellaneous Structures/ Hardware

- 8.1. A switch grounding platform used for protecting the switch operator in the event of a fault at the switch during manual operation shall be furnished for each group-operated switch. The platform shall be open-grating design with the grounding connector locations on opposite corners for attachment of 2/0 AWG copper as shown on the drawings.
- 8.2. Miscellaneous fastener hardware shall conform to the industry standards for the purpose for which they are to be used. Bolts, nuts, and washers for structural steel shall be hot-dip galvanized. Hardware shall be of low-alloy, corrosion-resistant steel, ASTM Specification A242.

All quantities of fastener hardware shall be shipped with a **minimum of ten percent (10%) overcount** above the designated quantity necessary for assembly.

## 9.0 Insulators

All insulators shall be wet-processed porcelain colored sky gray, shall conform to the IEEE Standards for insulators, and shall have the following minimum electrical mechanical characteristics:

### 9.1. Bus Insulators

Bus insulators for supporting bus and leads shall be standard station post non-stacking or uniform-diameter stack type meeting ANSI-BIL units complete with connectors, bolts, and washers as required:

Voltage Rating	25 kV	69 kV
BIL	150 kV	350 kV
Impulse Flashover-Positive	170 kV	390 kV
Low Frequency Withstand-Wet, 60 cycle	60 kV	145 kV
Leakage Distance, Inches	24	72
Mechanical Strength Tension Pounds	10,000	16,000
Insulators per Stack	1	1
Bolt Circle	3"	3"
Technical Reference Number	TR 208	TR 216

Bus insulators shall be as manufactured by Lapp, Locke, Newell, or approved equal.

## 10.0 **Bus and Leads**

The Drawings include a sheet of details to indicate the several methods to be used for connecting and supporting the bus and leads. The conductors shall be provided with the necessary supports and connectors as illustrated by these details. The hardware required for the conductor and overhead ground wire attachments shall be furnished by the Bidder and shall conform to the following specifications: ANSI C135 for bolts, ASTM A36 for steel, ASTM A47 for malleable iron and ASTM A153 for galvanizing. All hardware supplied shall be hot-dipped galvanized.

Bus and leads shall be as follows:

- 10.1. Primary rigid bus, 69 kV: 4-inch aluminum tubing, alloy 6063-T6, Schedule 40, with single conductor 336.4 kcmil ACSR internal damping cable.
- 10.2. Leads to and from 69 kV Breaker: 477 AAC.
- 10.3. Leads from 69 kV bus to transformer primary: 477 AAC, 19 strand.
- 10.4. Leads from the 67 to 26.18kV transformer secondary to secondary bus: Dual 954 AAC.
- 10.5. Secondary rigid bus, 25 kV, main bus - 3-inch and transfer bus - 2-inch: aluminum tubing, alloy 6063-T6, Schedule 40, with single conductor 336.4 kcmil ACSR internal damping cable.
- 10.6. Leads to and from feeder breakers: Single 954 AAC.
- 10.7. Surge arrester leads: 69 kV leads on 67 to 26.18 kV transformer mounted units: 477 AAC, via bolt-on tee. 25 kV leads on 67 to 26.18 x 13.09 kV transformer mounted units: 954 kcmil AAC via bolt-on tee to 954 kcmil AAC. 25 kV leads on outgoing distribution circuits: #2 AWG solid tinned copper.
- 10.8. Ground grid bus: 4/0 AWG S.D. bare copper, 7-strand.
- 10.9. Equipment and structure ground bonding leads:
  - a. Connections extending below grade shall have 2/0 or 4/0 S.D. bare copper, 7-strand.
  - b. Connections and runs existing only above grade shall be 2/0 AWG 40% conductivity 7-strand copper clad steel.
- 10.10. Transformer neutral and tank bonds: Single or parallel 2/0 or 4/0 S.D. bare copper, 7 strand.
- 10.11. Fence ground leads: #2 AWG copper clad.

## 11.0 **Bus Supports**

All substation tubular bus shall be supported by either fixed, slip-fit, or expansion attachment to the station post insulators using aluminum weldment tube to insulator fittings, as indicated on the Drawings. Bus supports shall be radio noise-free, equal to Travis.

## 12.0 **Connectors**

Connectors shall be suitable for the purpose they are intended and shall provide a sound electrical and mechanical connection.

The Bidder is responsible for supplying the connectors and hardware for all bus and leads and as defined in **Section 10.0 Bus and Leads**, and shown on the Drawings. A corrosion-inhibiting compound shall be furnished in a sufficient quantity to be applied to all connections. Non-gritted, Anderson Type VS compound shall be used on all bolted connections. Gritted, Anderson Type VSG compound shall be used on all compression connections.

- 12.1. All connector fittings to the tubular bus shall be aluminum weldment type as manufactured by Travis, unless otherwise shown in the Bill of Material.
- 12.2. Cable terminal fittings required for the incoming lines, bus leads around switches, equipment, and between switches and rigid bus shall be aluminum bolted or compression

type or bolted bronze type with the appropriate 2-hole or 4-hole NEMA spacing pad, as manufactured by Travis, unless otherwise shown on Bill of Material.

- 12.3. Expansion terminal connectors for tubular bus shall be aluminum weldment type for various locations as shown on the Drawings and as manufactured by Travis, unless otherwise shown on Bill of Material.
- 12.4. Grounding clamp connectors will be required for supporting or bonding the grounding cable to steel columns, beams, lightning masts, and/or fence/fabric posts. Supporting grounding clamp connectors will be required every four feet (4') minimum for columns and beams to minimize the sag in the cable.
- 12.5. A copper to aluminum bimetallic transition plate shall be provided for all non-similar connections between terminal connections on all equipment, including transformers, breakers, and switches to bus leads, where it is necessary to make an aluminum to copper connection. The transition plates shall be equal to Travis Type TP.
- 12.6. All hardware supplied for bolted aluminum-to-aluminum electrical fittings shall be stainless steel, 18-8 alloy.
- 12.7. All hardware supplied for bolted aluminum-to-copper electrical fittings shall be stainless steel 18-8 alloy.
- 12.8. All hardware supplied for bolted copper-to-copper electrical fittings shall be stainless steel 18-8 alloy.
- 12.9. All quantities of fastener hardware shall be shipped with **a minimum ten percent (10%) over count** above the designated quantity necessary for assembly.
- 12.10. Bidder to verify that all conductor terminal pads shall **match and fit onto switch terminal pads** with regard to pad size, NEMA rating and pad shoulder configurations.

### **13.0 Group-Operated Disconnect Switches**

#### 13.1. Switch Construction

The switches shall meet all applicable ANSI and other industry mechanical and electrical standards, and shall be completely assembled and adjusted at the factory. The switches shall be of the manual-operating type by means of an operator pipe handle, and all parts of the operating mechanism shall be furnished for installing the complete three-phase switch and mechanism on the supporting structure. The switches shall be physically sized to fit properly in the locations shown on the Drawings. Switches shall be suitable for either horizontal or vertical mounting. A galvanized steel double-channel base plate shall be furnished and drilled for the particular installation prior to galvanizing.

The switches shall be of copper or aluminum construction with tin-plated copper contacts for both the center contacts and the hinge contacts.

All switches shall be complete with stainless steel arcing horns, pipe handle operating mechanism for manual operation, outboard bearings guide plate, operating pipe, and flexible grounding braid, an open- and closed-position indicator, and provisions for pad-locking in either the open or closed position. Oilite bearings shall be used for moving parts not provided with greaseless ball-bearing assemblies having stainless steel balls and races. Bearings shall be permanently sealed and require no greasing or other field maintenance. The switches shall be designed such that when they are fully open to ninety degrees (90°), the metal-to-metal spacing to the adjacent phase will not be less than specified for each voltage class. Switch terminals shall be provided with 4-hole NEMA spacing electro tin-plated terminals for copper or aluminum conductor connections as per the Drawings.

The switch insulators shall be ANSI No. 70 sky gray standard or high strength, non-tapered, uniform-diameter stacks, station post with three or five inch (3-inch or 5-inch) diameter bolt circles both top and bottom. The switch shall be two (2) or three (3) insulators per



pole, as indicated on the Drawings. The switch insulators shall be free to rotate without affecting the position of the terminal pads.

13.2. Ratings for 69 kV Group-Operated Switches

13.2.1. Vee-type, center-break, group-operated air-break switch located on the A-frame shall be outdoor type, two-insulator, group-operated, air-break disconnect, complete with arcing horns, operating mechanism for pipe operation, outboard bearing, and guide plate. Oilite bearings shall be used for moving parts not provided with greaseless ball-bearing assemblies having stainless steel balls and races. Terminals shall be tin-plated NEMA four-hole suitable for bronze or aluminum conductor connectors as per the Drawings. High-side switches shall be 69 kV nominal, 350 kV BIL, 1200 Ampere continuous, 61,000 Ampere momentary. Switches shall be completely assembled with TR 216 standard strength post insulators.

13.2.2. Vertical break, group-operated air break switches located on the 69kV bus shall be outdoor type, three (3) insulator, group operated, air-break disconnect, complete with arcing horns, operating mechanism for pipe operation, outboard bearing, and guide plate. Oilite bearings shall be used for moving parts not provided with greaseless ball-bearing assemblies having stainless steel balls and races. Terminals shall be tin-plated NEMA four-hole suitable for bronze or aluminum conductor connectors as per the Drawings. High-side switches shall be 69 kV nominal, 350 kV BIL, 1200 Ampere continuous, 61,000 Ampere momentary. Switches shall be completely assembled with TR 216 standard strength post insulators.

13.3. Ratings for 25 kV Group-Operated Switches

13.3.1. Vee-type center-break disconnect switches located on the 25 kV main secondary bus shall be rated 27 kV, 150 kV BIL, 2000 Amperes continuous, 80,000 Amperes momentary, **completely assembled** with TR-208 standard-strength, post insulators with pipe handle manual operator mechanism.'

13.3.2. Vee-type center-break disconnect switches located on the 25 kV transfer bus shall be rated 27 kV, 150 kV BIL, 1200 Amperes continuous, 61,000 Amperes momentary, completely assembled with TR 208 standard strength post insulators with pipe handle manual operator mechanism.

13.4. Approved Switch Manufacturers and Alternates

All bids for substation structures and equipment shall incorporate only switches as approved and noted herein. The Bidder may offer an alternate quotation for an alternate switch. **However, all base bids must include the type switch so designated below.**

13.4.1. 69 kV, 1200 Ampere group-operated switches per Section 13.3.1:  
All Base Bids: Cleaveland-Price C26A018G01 / CB-AV or approved equivalent

13.4.2. 69 kV, 1200 Ampere group-operated switches per Section 13.3.2:  
All Base Bids: Cleaveland Price C06A032G22 / V2-CA or approved equivalent

13.4.3. 25 kV, 2000 Ampere vee-type center-break group-operated switches per Section 13.4.1:  
All Base Bids: Cleaveland Price C26A39G02 / CB-CV or approved equivalent

13.4.4. 25 kV, 1200 Ampere vee-type center-break group-operated switches per Section 13.4.2:  
All Base Bids: Cleaveland Price C26A038G02 / CB-CV or approved equivalent

**14.0 Surge Arresters**

Surge arresters for the high- and low-voltage sides for the power transformers will be provided by the power transformers manufacturer, as furnished by the Owner.

Surge arresters on the incoming 69 kV A-Frame shall be furnished by the Bidder and shall be surge type, sky gray metal oxide, base-mounted, polymer, Station Class rated as follows:

<u>Nominal Voltage</u>	<u>MCOV Arrester Rating</u>	<u>Location</u>	<u>Class</u>	<u>Type</u>
69 kV	48 kV	69 kV A-Frame	Station	EVP

Surge arresters for the 25 kV circuit exits shall be furnished by the Bidder and shall be surge type, polymer, sky gray, metal oxide, Station Class rated as follows:

<u>Nominal Voltage</u>	<u>MCOV Arrester Rating</u>	<u>Location</u>	<u>Class</u>	<u>Type</u>
13.2/7.2 kV	8.4 kV	15 kV Circuit Exits	Station	EVP

Metal oxide surge arresters are rated in terms of maximum continuous operating voltage (MCOV). However, metal oxide arresters which are given conventional ratings may be furnished if the MCOV equivalent ratings are as specified here.

The 48 kV MCOV station class surge arresters shall be provided with a 4-hole NEMA spacing terminal on the line-side bushing terminals and ground connectors suitable for a maximum 250 kemil copper (loop configuration) on the arrester base. The distribution structure MCOV station class arresters shall include line and ground connectors for up to #2 stranded tinned copper.

The surge arresters shall comply with ANSI Standard C-62.1.

## 15.0 Single-Pole Disconnect Switches

The switches shall be outdoor type, meet all applicable ANSI, NEMA and other industry mechanical and electrical standards, and shall be completely assembled and adjusted at the factory. The switches shall be physically sized to fit properly in the locations shown on the Drawings. Switches shall be suitable for either horizontal or vertical mounting, as shown on the Drawings. A galvanized steel channel base plate shall be furnished and drilled for the particular installation prior to galvanizing.

The switches shall be of copper construction with electro tin-plated contacts for both the jaw and the hinge contacts. The switch terminals shall be provided with 2-hole or 4-hole NEMA spacing, electro tin-plated terminals for copper or aluminum conductor connectors as per the Drawings.

Bidder to verify that all conductor terminal pads shall **match and fit onto switch terminal pads** with regard to pad size, NEMA rating and pad shoulder configurations.

The power fuses shall be outdoor type, meet all applicable ANSI, NEMA and other industry mechanical and electrical standards, and shall be completely assembled at the factory. Fuse mounting hardware shall consist of the base, insulators, complete upper and lower contact assemblies, terminal connectors sized for specified cable as shown on the Drawings, and fuse unit end fittings. The mounting shall be suitable for vertical offset or inverted installation.

The 25 kV switch and fuse insulators shall be ANSI No. 70 sky gray, post type, TR-208 standard strength (or TR-227 high-strength, as required), with three or five inch (3-inch or 5-inch) diameter bolt circles both top and bottom. The switches shall be shipped completely assembled on bases with post insulators oriented to accommodate the appropriate mounting location.

### 15.1. Hookstick Switches

High-side switches shall be 69 kV nominal, 350 kV BIL, 1200 Ampere continuous, 61,000 Ampere momentary. Switches shall be completely assembled with TR 216 standard strength post insulators. Switches shall be Cleaveland-Price model C102A150G17 Type LCO-C or approved equivalent.

Single-pole hookstick disconnect switches shall be provided for isolation of the 25 kV feeder vacuum circuit breakers, and shall be rated 27 kV, 150 kV BIL, 1200 Amperes continuous, 61,000 Amperes momentary. The 27 kV, 1200 Ampere hookstick disconnect switches shall be Cleaveland-Price model C102A230G08 Type LCO-C or approved equivalent.

#### 15.2. Fuses and Fuse Mounting Hardware

Fuses, fuse barrels and fuse mounting hardware shall be provided for isolation of the 25 kV station service transformers and potential transformers. One (1) fuse (and end fittings) of the proper rating shall be supplied with each mounting, plus additional spares, as specified on the Bill of Materials.

15.2.1. Fuses and mountings to be provided for the station service transformers shall be rated similar to S & C Type SMD-20 power fuse equipped with a current limiting fuse, or approved equal.

15.2.2. Fuses and mountings to be provided for the potential transformers shall be rated similar to S & C Type SMD-20 power fuse equipped with a current limiting fuse, or approved equal.

15.2.3. Current limiting fuses shall be Type “K-Mate” 50,000 A.I.C., rated 12 Amperes, or approved equal.

15.2.4. Insulators for fuse mounting shall be rated for 25 kV, TR-208.

#### 16.0 Hookstick and Container

One (1) station class hookstick shall be provided as follows: one (1) sixteen-foot (16'), fiberglass stick similar or equal to Hastings 541-16. An appropriate length storage container, along with fence mounting kit shall be supplied with each hookstick.

#### 17.0 Instrument Transformers

Potential transformers (PTs) shall be provided by the Bidder for use of metering the medium voltage bus. PTs shall be outdoor type, metering class, single primary, tapped secondary, 60 cycle, dual bushing.

The PTs shall be ABB Type PTT-110-977 or ABB Type VOZ-11, or approved equal.

#### 18.0 Distribution Transformers

The Owner will supply one (1) 120/240 volts distribution transformers to supply ac station service for the substation equipment in the 69 to 15 x 25 kV Substation.

The Bidder shall provide mounting provisions for this transformer on the structure in the location as shown on the Drawings included with these Specifications. The Bidder shall assure the mounting clearance between the transformer’s primary insulator and the power fuse mounting base or truss exceeds the minimum clearance requirements of the National Electrical Safety Code. The Bidder shall also assure that National Electrical Safety Code requirements are met for minimum distance to the ground for personal safety.

All transformers utilize an industry standard hanger bracket with two (2) 5/8” (5/8”) bolts in-line on eleven and one quarter-inch (11-1/4”) spacing.

#### 19.0 Station Grounding

a. The station grounding below grade conductors shall be provided by the Contractor as follows: Ground grid bus: 4/0 AWG bare SD copper, 7-strand, 2/0 AWG bare SD copper, 7-strand for perimeter conductor

b. The fence grounding conductors shall be provided by the bidder as follows: Fence ground leads: #2 AWG bare SD copper clad.

- c. Equipment and structure ground bonding leads:
  - 1) Connections extending below grade shall have 2/0 or 4/0 S.D. bare copper, 7-strand.
  - 2) Connections and runs existing only above grade shall be 2/0 AWG 40% conductivity 7-strand copper clad steel.
- d. The transformer ground bonding leads shall be provided by the Contractor as follows: Dual 4/0 AWG, SD copper, 7-strand.
- e. Ground rods shall be provided by the Contractor and shall be Copperweld three-fourths inch (3/4") diameter, ten feet (10'-0") in length, of the sectional type. Ground rod connections shall be Cadweld type, suitable for 4/0 AWG copper ground bus. Drive heads and couplings shall be furnished with the sectional rods.
- f. All connections below grade shall be Cadweld and shall be provided by the Contractor.
- g. All fence grounding connectors as shown in the Bill of Materials shall be provided by the Bidder.

## **20.0 List of Materials – Substation Structures and Equipment**

A list of the major items required for the substation is included in the appendices. Items noted as "(N/A)" in the list are to be furnished by Owner.

## **APPENDICES**

1. Booth & Associates, LLC – Drawing List
2. Bill of Materials
3. Vicinity Map

**PUBLIC WORKS COMMISSION  
FAYETTEVILLE, NORTH CAROLINA**

**CUMBERLAND ROAD SUBSTATION**

<b>LIST OF DRAWINGS</b>
-------------------------

The work shall conform to the following Booth and Associates, LLC Drawings, all of which form a part of these Specifications. The Contractor is responsible for contacting the Engineer if any drawings not indicated to be furnished at a later date are missing from their bid package. If the Bidder does not contact the Engineer regarding any drawings, their bid will be considered based on all Drawings and Specifications, as issued for bids.

**STRUCTURES AND EQUIPMENT**

Sheet No.	Title
GA-1	Plan View
GA-2	Section Views A-A, B-B
GA-3	Section View C-C, D-D
GA-4	Section Views E-E, F-F, G-G, H-H
GA-5	Details

**SITE DRAWINGS**

Sheet No.	Title
E1	One-Line
G1	Grounding Plan
G2	Grounding Details

**STEEL DRAWINGS**

Sheet No.	Title
ED1	Overall Erection Diagram
ED2	Overall Erection Diagram
ED3	Partial Erection Diagram
ED4	Overall Erection Diagram
ED5	Erection Diagram URD Stand Sections A-A, B-B
ED6	Erection Diagram Low-side Section C-C
ED7	Erection Diagram Low-side Section D-D
ED8	Erection Diagram Low-side Section E-E
ED9	Erection Diagram Low-side Section F-F
ED10	Erection Diagram Low-side Section G-G
ED11	Erection Diagram A-Frame Section H-H
ED12	Erection Diagram Low Bus Stand / A-Frame Section J-J
ED13	Erection Diagram High Switch Stand Sections L-L, M-M Erection Diagram Low Switch Stand Sections N-N, O-O

**STEEL DRAWINGS** *continued*

Sheet No.	Title
AB1	Anchor Bolt Plan & Details
AB2	Anchor Bolt Plan & Details
LS01	Low-side Details (Trusses)
LS02	Low-side Details (Trusses)
LS03	Low-side Details (Trusses)
LS04	Low-side Details (Trusses)
LS05	Low-side Details (Trusses)
LS06	Low-side Details (Trusses)
LS07	Low-side Details (Trusses)
LS08	Low-side Details (Trusses)
LS09	Low-side Details (Trusses)
LS10	Low-side Details (Trusses)
LS11	Low-side Details (Trusses)
LS12	Low-side Details (Trusses)
LS13	Low-side Details (Trusses)
LS14	Low-side Details (Trusses)
LS15	Low-side Details (Trusses)
LS16	Low-side Details (Trusses)
LS17	Low-side Details (Trusses)
LS18	Low-side Details (Trusses)
URD1	URD Stand Details
URD2	URD Stand Details
URD3	URD Stand Details
AF1	A-Frame Steel Detail
AF2	A-Frame Steel Detail
AF3	A-Frame Steel Detail
AF4	A-Frame Steel Detail
AF5	A-Frame Steel Detail
AF6	A-Frame Steel Detail
AF7	A-Frame Steel Detail
AF8	A-Frame Steel Detail
SS1	Low Switch Stand
SS2	Low Switch Stand

**STEEL DRAWINGS** *continued*

Sheet No.	Title
SS3	High Switch Stand
SS4	High Switch Stand
SS5	Switch Stand
SS6	Switch Stand
BUS1	Single-Phase Bus Stand
TPB1	Three-Phase Bus Stand
TPB2	Three-Phase Bus Stand
TPB3	Three-Phase Bus Stand
GM1	Grounding Mat Detail
BS1	Bolt Schedule
SM1	Static Mast Detail
SM2	Static Mast Detail
SM3	Static Mast Detail
SM4	Static Mast Detail



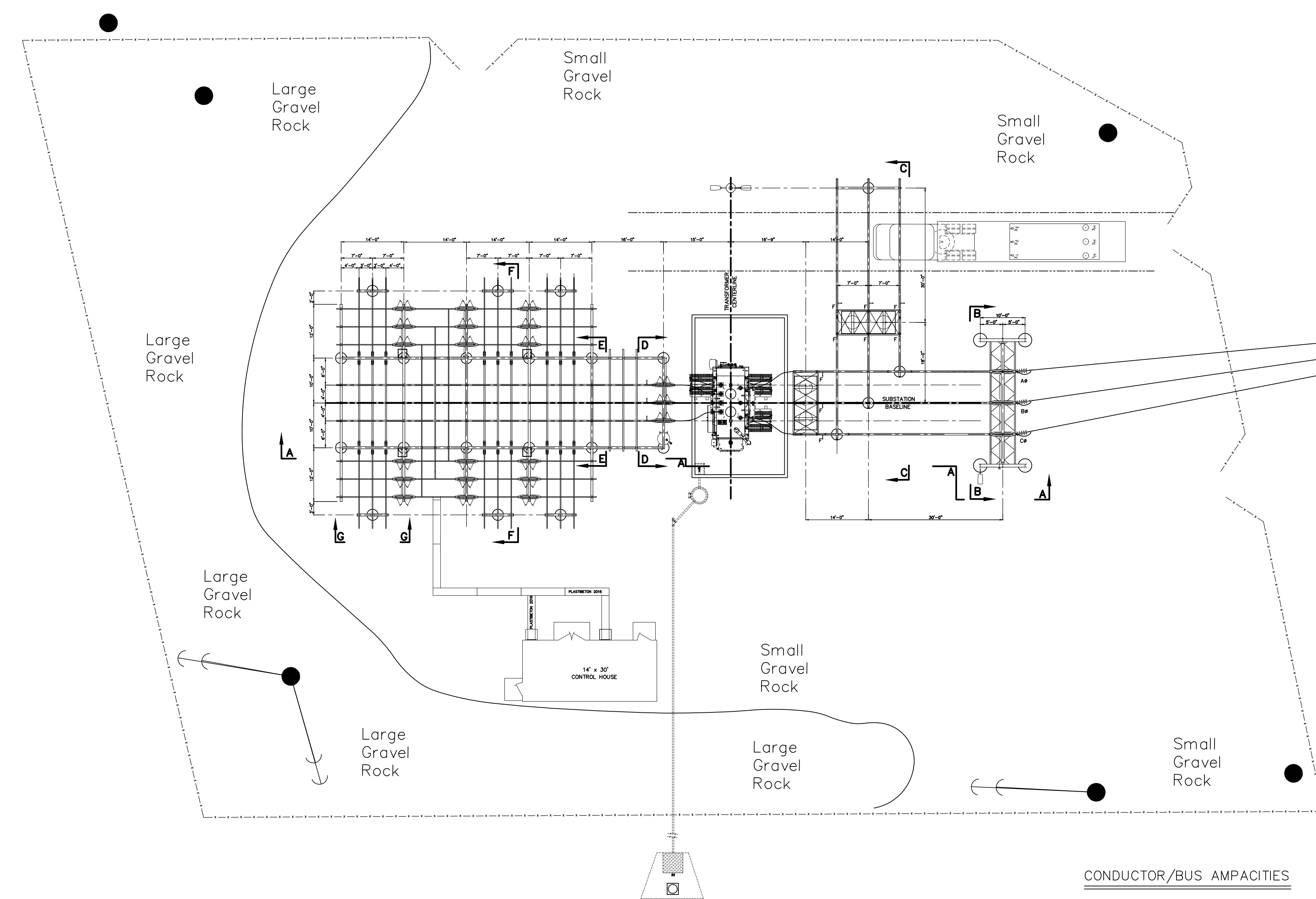

PLAN VIEW  
SCALE: 3/32" = 1'-0"

STATION DESIGN DATA									
STRUCTURE, APPARATUS AND LIGHTNING ARRESTERS ARE ALL GROUNDED TO THE SAME GROUNDING SYSTEM. STATION DESIGNED FOR THE FOLLOWING ELECTRICAL CLEARANCES/SPACINGS:									
RATED KV	BIL KV	RIGID BUS CONDUCTORS (IEEE, NEMA, NESC)				VERTICAL CLEARANCE OF UNGUARDED PARTS	GROUP-OPERATED SWITCHES (NEMA)		
		PHASE TO PHASE TO C (3)	METAL TO METAL (4)	PHASE TO GROUND (5)	CLEARANCE ABOVE GRADE (6)		HORN GAP VERT./HOR. BREAK	DISCONNECT VERTICAL BREAK	DISCONNECT HORIZONTAL BREAK
69	350	5'-0"	2'-7"	2'-6"	11'-0"	10'-5"	7'-0"	5'-0"	6'-0"
15	110	2'-0"	0'-12"	0'-10"	9'-0"	9'-0"	3'-0"	2'-0"	2'-6"

NOTES:  
 1. "CLEARANCE" IS DEFINED AS A SURFACE-TO-SURFACE MEASUREMENT.  
 2. "SPACING" IS DEFINED AS A C TO C MEASUREMENT.  
 3. INTENDED FOR PHASES ORIENTED IN PARALLEL RUNS.  
 4. INTENDED FOR NON-PARALLEL POINTS OF CROSSING.  
 5. EXCEEDS MINIMUM CLEARANCES TO MATCH NEMA STANDARD POST INSULATOR DIMENSIONS.  
 6. ROUNDED UP TO THE NEAREST EVEN FOOT, PER NESC (2002). MEASURED FROM TOP OF EQUIPMENT FOUNDATIONS, IF SUITABLE FOR PEDESTRIAN ACCESS.

DEADEND STRUCTURE(S) SHALL WITHSTAND 0' TO 15' LINE TAKE-OFF IN ANY DIRECTION WITH A DESIGN LINE TENSION OF \_\_\_\_\_ POUNDS PER CONDUCTOR.  
 \*A MINIMUM VERTICAL CLEARANCE OF 8'-6" SHALL BE MAINTAINED FOR ANY SURFACE OF INDETERMINATE POTENTIAL SUCH AS LIGHTNING ARRESTERS, UNGROUNDED SURFACES, BUSHINGS, AS PER NESC RULE 124.A.3.

EQUIPMENT BOLT TORQUING TABLE		
DIAMETER BOLT (INCHES)	RECOMMENDED TORQUE NON-LUBRICATED STEEL & SILICON BRONZE HARDWARE (FOOT*LB)	RECOMMENDED TORQUE LUBRICATED HARDWARE & ALUMINUM HARDWARE (FOOT*LB)
1/2"	40	25
5/8"	55	40
3/4"	70	60

CONDUCTOR/BUS AMPACITIES	
CONDUCTOR	APPROX. CURRENT CARRYING CAPACITY*
TUBING, 4" NPS SCH. 80 AL.	3720 AMPS.
TUBING, 3" NPS SCH. 80 AL.	2760
TUBING, 2" NPS SCH. 80 AL.	1700
TUBING, 4" NPS SCH. 40 AL.	3165
TUBING, 3" NPS SCH. 40 AL.	2425
TUBING, 2" NPS SCH. 40 AL.	1465
ACSR, 1272 MCM, 26/7	1200
ACSR, 954 MCM, 26/7	1010
ACSR, 795 MCM, 26/7	900
ACSR, 336.4 MCM, 18/1	530
ACSR, 2/0 AWG, 6/1	340
ACSR, 1/0 AWG, 6/1	230
COPPER, 1000 MCM, 61 STD.	1285
COPPER, 750 MCM, 61 STD.	1075
COPPER, 500 MCM, 37 STD.	830
COPPER, 4/0 AWG, 7 STD.	480
COPPER, 2/0 AWG, 7 STD.	355
COPPER, #2 AWG, SOLID	231
UABC, 4" x 4" x 3/8"	3125
UABC, 4" x 4" x 1/4"	2625
AL BAR 3" x 1/2"	1350
AL BAR 3" x 1/4"	938
INSUL. 1/0 34.5KV J.C.N.	235

\* AC. 60 HZ, 40° C AMBIENT, 50° C RISE HORIZONTAL ORIENTATION, OUTDOORS, WIND = 2 FPS

- INSTALLATION NOTES:
- MATERIALMAN/FABRICATOR VERIFY THAT CONDUCTOR TERMINAL PADS MATCH AND FIT ONTO SWITCH TERMINAL PADS (SIZE, NEMA RATING AND SHOULDER).
  - EQUIPMENT VIEW IS PRELIMINARY. WAITING ON VENDOR DRAWINGS.
  - CONTRACTOR TO BRING GRADE AROUND NEW A-FRAME UP TO MATCH FOUNDATION REVEALS TO ALLOW ACCESS TO BREAKER AND SWITCH OPERATORS.
  - MINOR GRADING TO BE DISCUSSED AT PRE-BID MEETING

- LEGEND:
- ⊙ STATIC POLE
  - AREA LIGHTS
  - F FIXED CONNECTION
  - S SLIP FIT

- REFERENCES
- SITE PLAN \_\_\_\_\_ 12510S1
  - SECTION VIEWS \_\_\_\_\_ 12510GA2-GA4
  - DETAILS \_\_\_\_\_ 12510GA5
  - FOUNDATION PLAN \_\_\_\_\_ 12510FD1

NO.	ISSUED FOR BID	REVISIONS	ENG.	DATE
A			BWJ	05/04/23

PROJECT NAME:	CUMBERLAND ROAD 69 TO 15 X 25 KV SUBSTATION
DRAWING TITLE:	PLAN VIEW
DRAWN BY:	JRT
CHECKED BY:	DAW
APPROVED BY:	MJW
DATE:	3/16/2022
SCALE:	3/32"=1'-0"
FILE NUMBER:	12510
SHEET:	

PRELIMINARY -  
DO NOT USE FOR  
CONSTRUCTION

© 03/2022

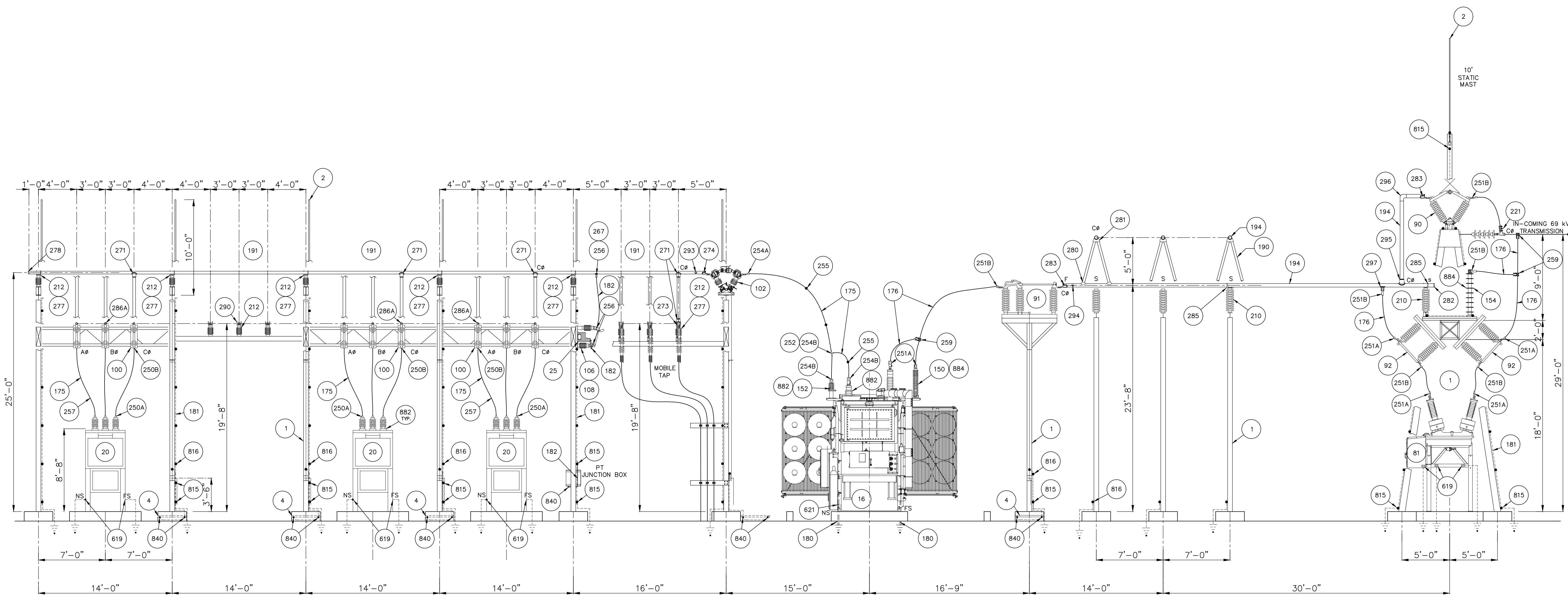

SECTION A-A  
SCALE: 3/16"=1'-0"

- INSTALLATION NOTES:**
1. MATERIALMAN/FABRICATOR VERIFY THAT CONDUCTOR TERMINAL PADS MATCH AND FIT ONTO SWITCH TERMINAL PADS (SIZE, NEMA RATING AND SHOULDER).
  2. EQUIPMENT VIEW IS PRELIMINARY. WAITING ON VENDOR DRAWINGS.
  3. CONTRACTOR TO BRING GRADE AROUND NEW A-FRAME UP TO MATCH FOUNDATION REVEALS TO ALLOW ACCESS TO BREAKER AND SWITCH OPERATORS.

**REFERENCES**

SITE PLAN	12510S1
PLAN VIEW	12510GA1
SECTION VIEWS	12510GA2-GA4
DETAILS	12510GA5
FOUNDATION PLAN	12510FD1
GROUNDING PLAN	12510G1
CONDUIT PLAN	12510C1

NO.	ISSUED FOR BID	REVISIONS	ENG.	DATE
A			BMJ	05/04/23

PROJECT NAME:	CUMBERLAND ROAD 69 TO 15 X 25 kV SUBSTATION
DRAWING TITLE:	SECTION A-A
DRAWN BY:	JRT
CHECKED BY:	DAW
APPROVED BY:	MJW
DATE:	3/16/2022
SCALE:	3/16"=1'-0"
FILE NUMBER:	12510
SHEET:	GA2

PRELIMINARY -  
DO NOT USE FOR  
CONSTRUCTION

© 03/2022

NO.	ISSUED FOR BID	REVISIONS	ENG.	DATE
A			BWJ	05/04/23

PROJECT NAME:	CUMBERLAND ROAD 69 TO 15 X 25 KV SUBSTATION
DRAWING TITLE:	SECTIONS B-B, C-C
DRAWN BY:	JRT
CHECKED BY:	DAW
APPROVED BY:	MJW
DATE:	3/16/2022
SCALE:	3/16"=1'-0"
FILE NUMBER:	12510
SHEET:	GA3

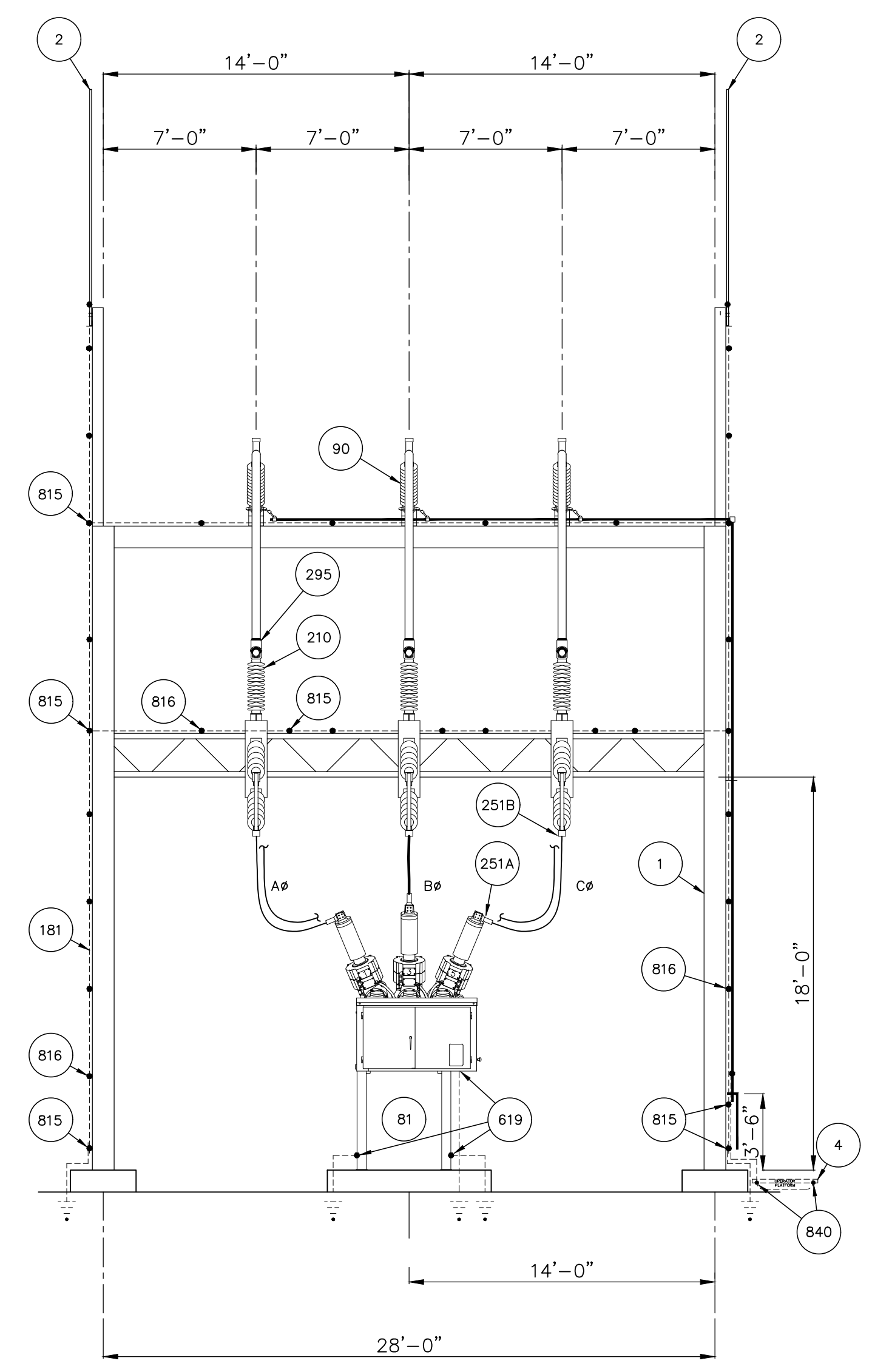

**SECTION B-B**  
SCALE: 3/16"=1'-0"

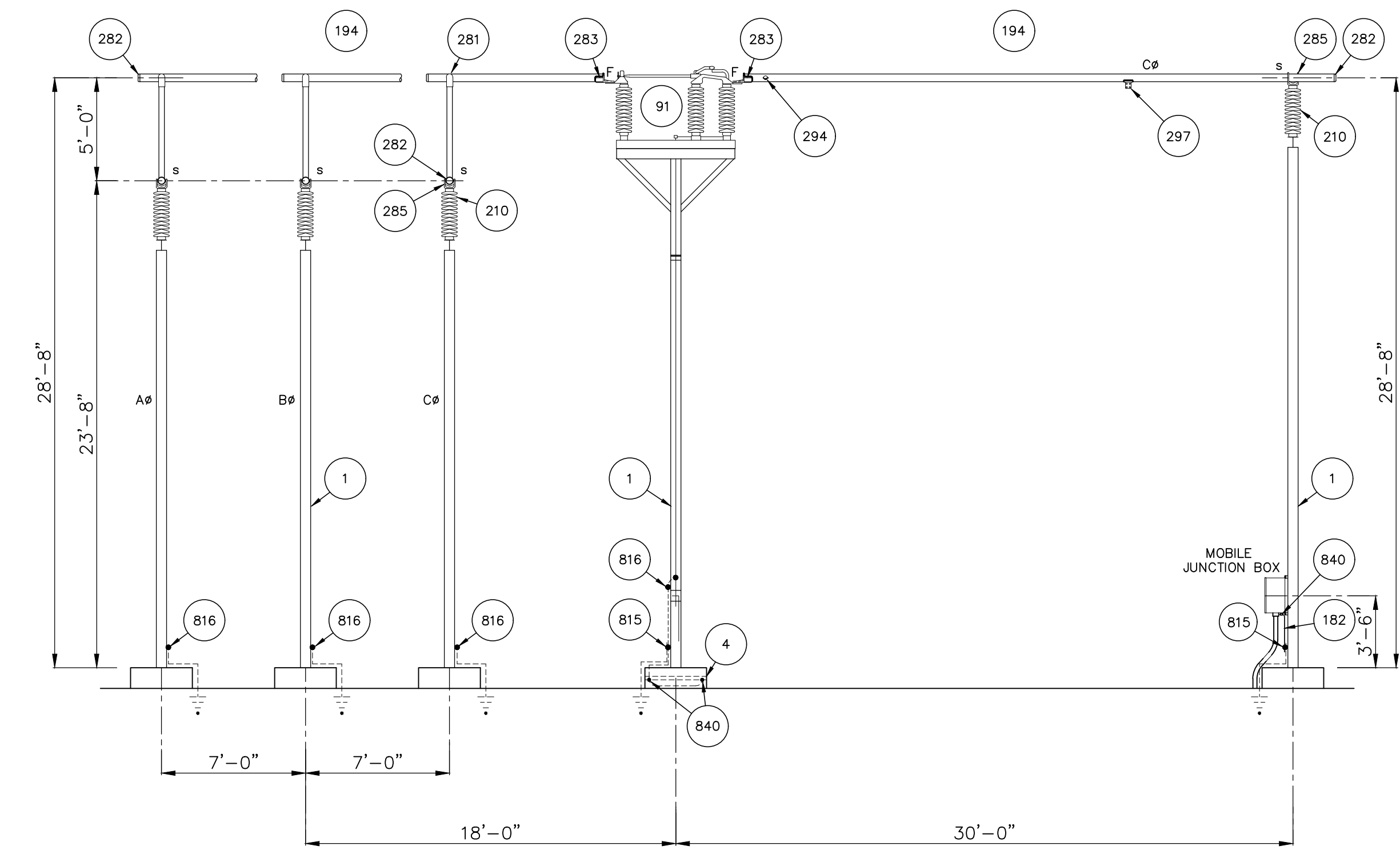

**SECTION C-C**  
SCALE: 3/16"=1'-0"

**INSTALLATION NOTES:**

1. MATERIALMAN/FABRICATOR VERIFY THAT CONDUCTOR TERMINAL PADS MATCH AND FIT ONTO SWITCH TERMINAL PADS (SIZE, NEMA RATING AND SHOULDER).
2. EQUIPMENT VIEW IS PRELIMINARY. WAITING ON VENDOR DRAWINGS.

**REFERENCES**

SITE PLAN	12510S1
PLAN VIEW	12510GA1
SECTION VIEWS	12510GA2-GA4
DETAILS	12510GA5
FOUNDATION PLAN	12510FD1
GROUNDING PLAN	12510G1
CONDUIT PLAN	12510C1

PRELIMINARY -  
DO NOT USE FOR  
CONSTRUCTION

© 03/2022

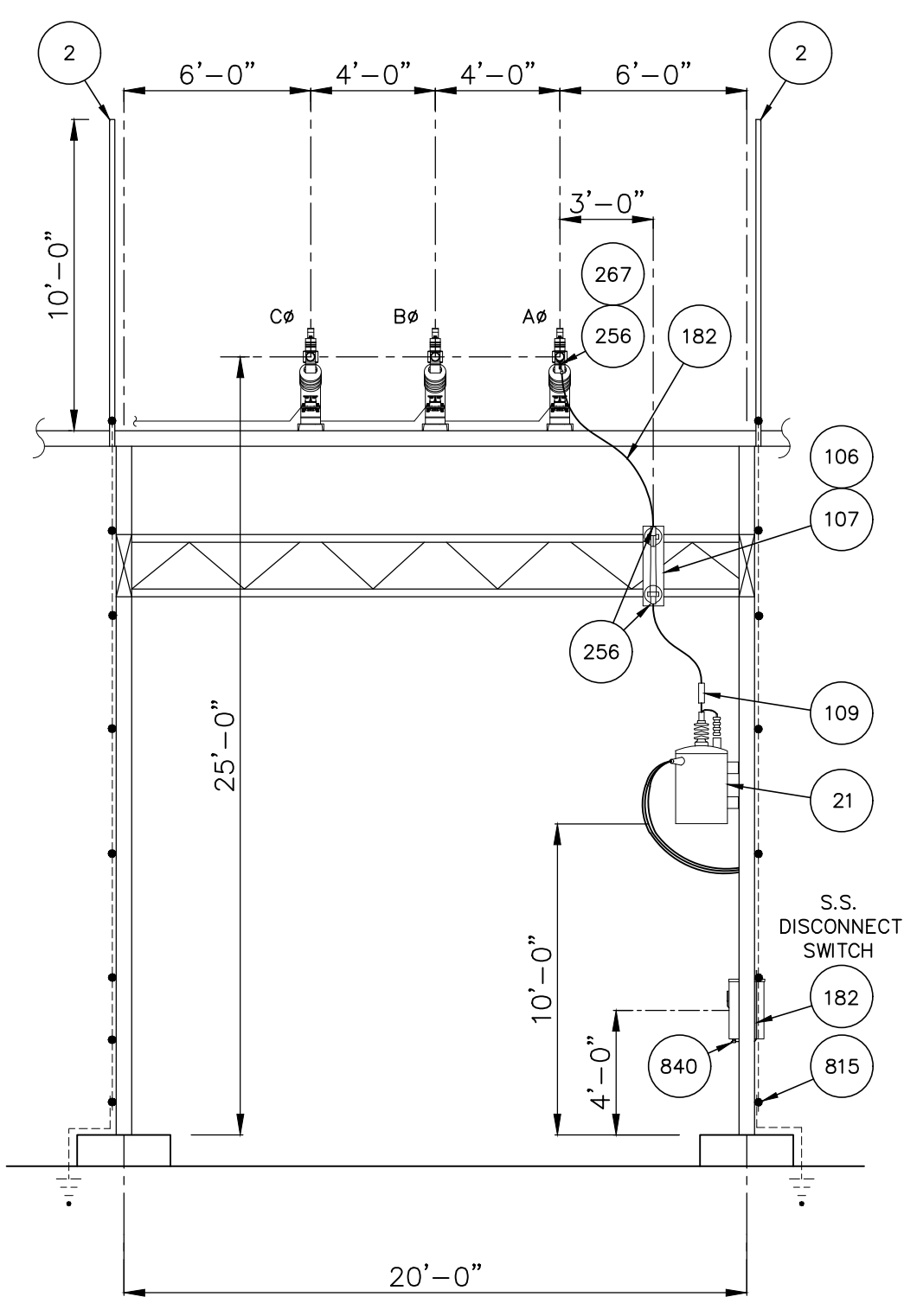

SECTION D-D  
SCALE: 3/16"=1'-0"

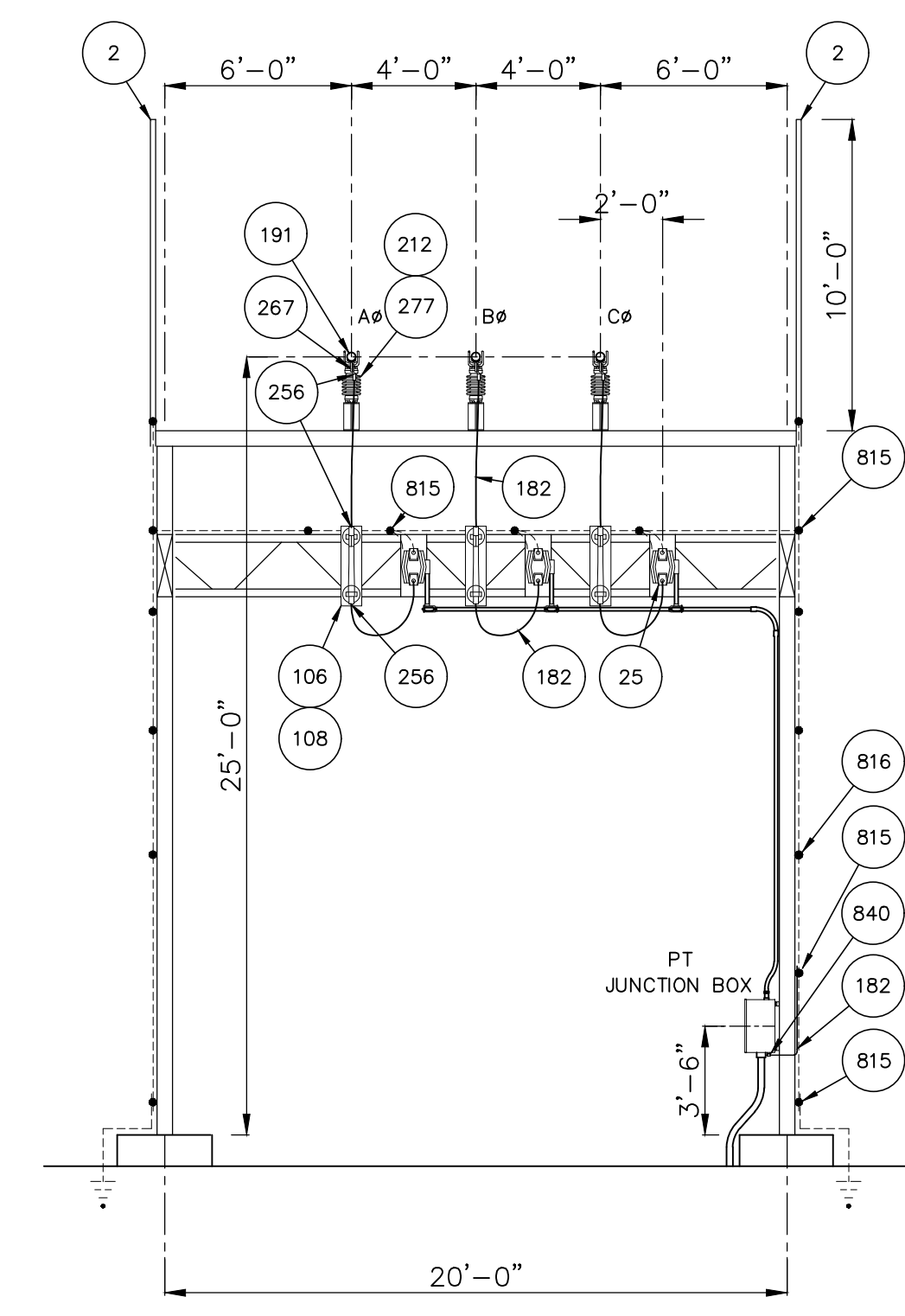

SECTION E-E  
SCALE: 3/16"=1'-0"

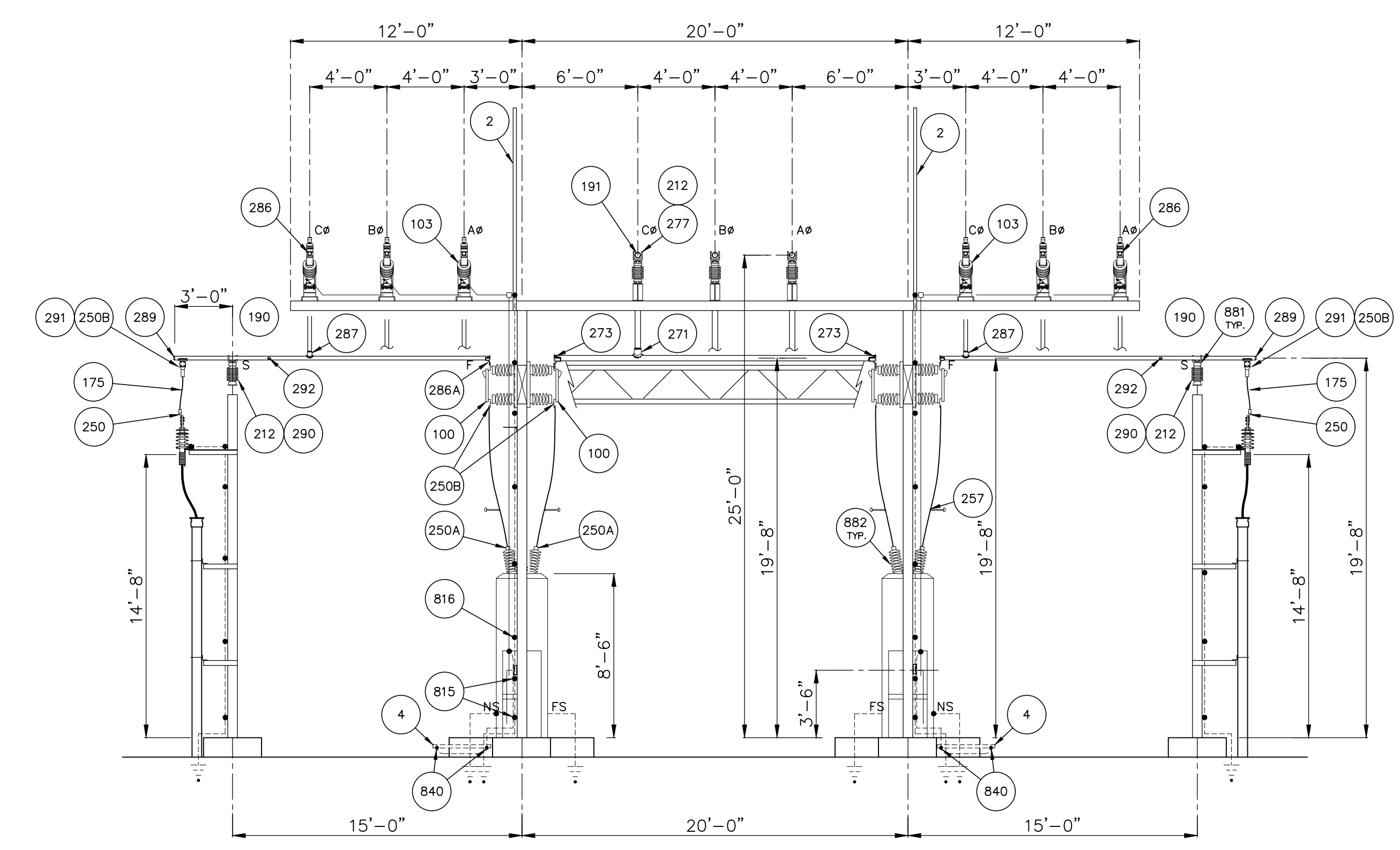

SECTION F-F  
SCALE: 3/16"=1'-0"

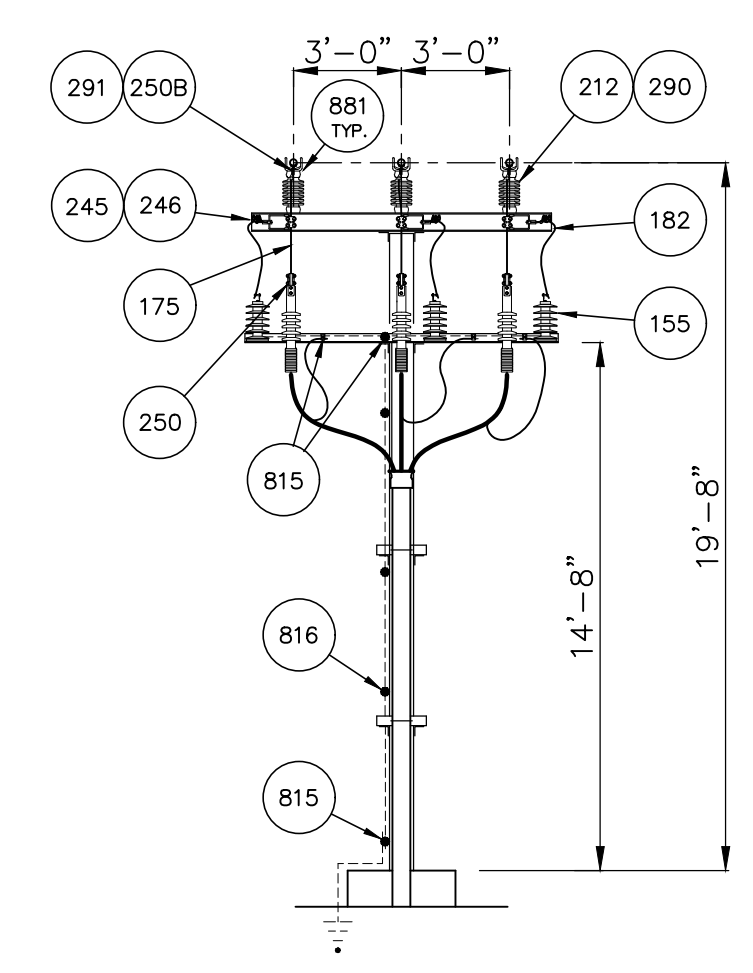

SECTION G-G  
SCALE: 3/16"=1'-0"

**INSTALLATION NOTES:**

1. MATERIALMAN/FABRICATOR VERIFY THAT CONDUCTOR TERMINAL PADS MATCH AND FIT ONTO SWITCH TERMINAL PADS (SIZE, NEMA RATING AND SHOULDER).
2. EQUIPMENT VIEW IS PRELIMINARY. WAITING ON VENDOR DRAWINGS.

**REFERENCES**

SITE PLAN	12510S1
PLAN VIEW	12510GA1
SECTION VIEWS	12510GA2-GA4
DETAILS	12510GA5
FOUNDATION PLAN	12510FD1
GROUNDING PLAN	12510G1
CONDUIT PLAN	12510C1

NO.	ISSUED FOR BID	REVISIONS	ENG.	DATE
A			BMJ	05/04/23

PROJECT NAME: CUMBERLAND ROAD  
69 TO 15 X 25 KV  
SUBSTATION  
DRAWING TITLE:

SECTIONS D-D, E-E, F-F, G-G

DRAWN BY:	JRT
CHECKED BY:	DAW
APPROVED BY:	MJW
DATE:	3/16/2022
SCALE:	3/16"=1'-0"
FILE NUMBER:	12510
SHEET:	

TUBE	BOLT CIRCLE	A	B	BOM ITEM
2"	3"	6 3/4"	2 3/4"	290
3"	3"	6 3/4"	3 5/8"	277
4"	3"	9 1/8"	4 1/2"	285

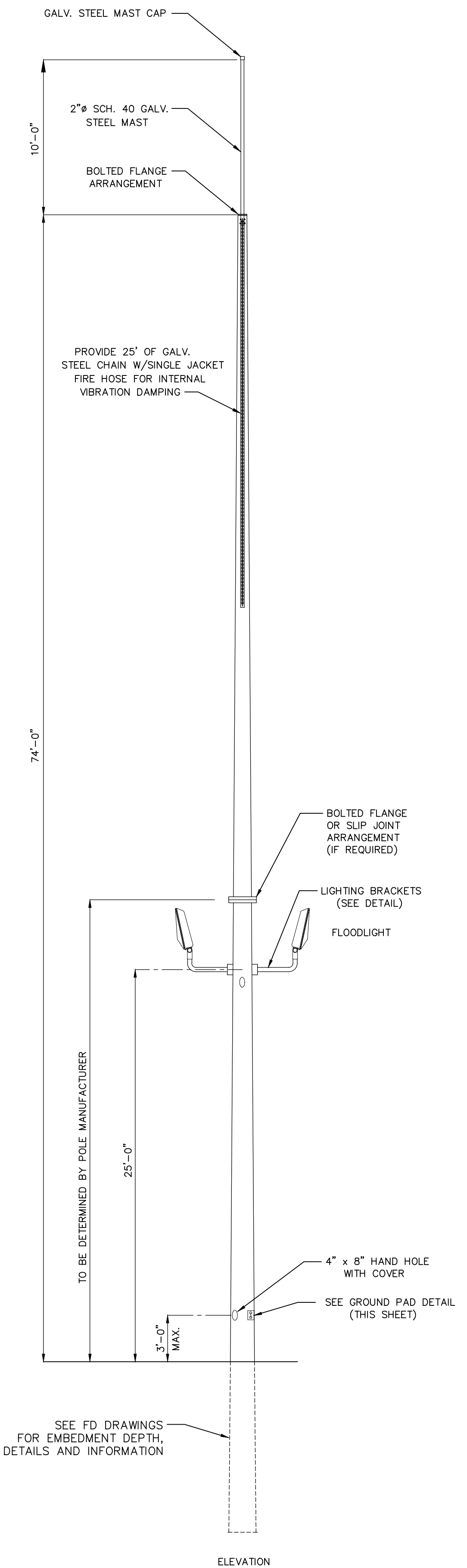
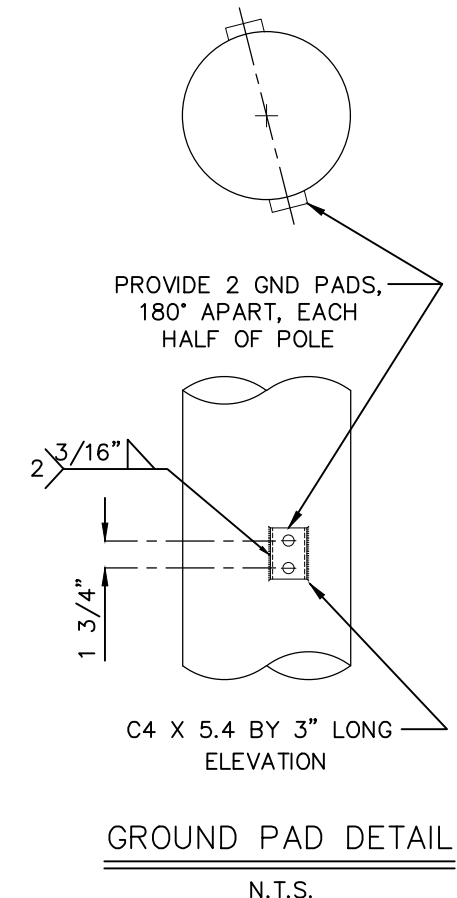
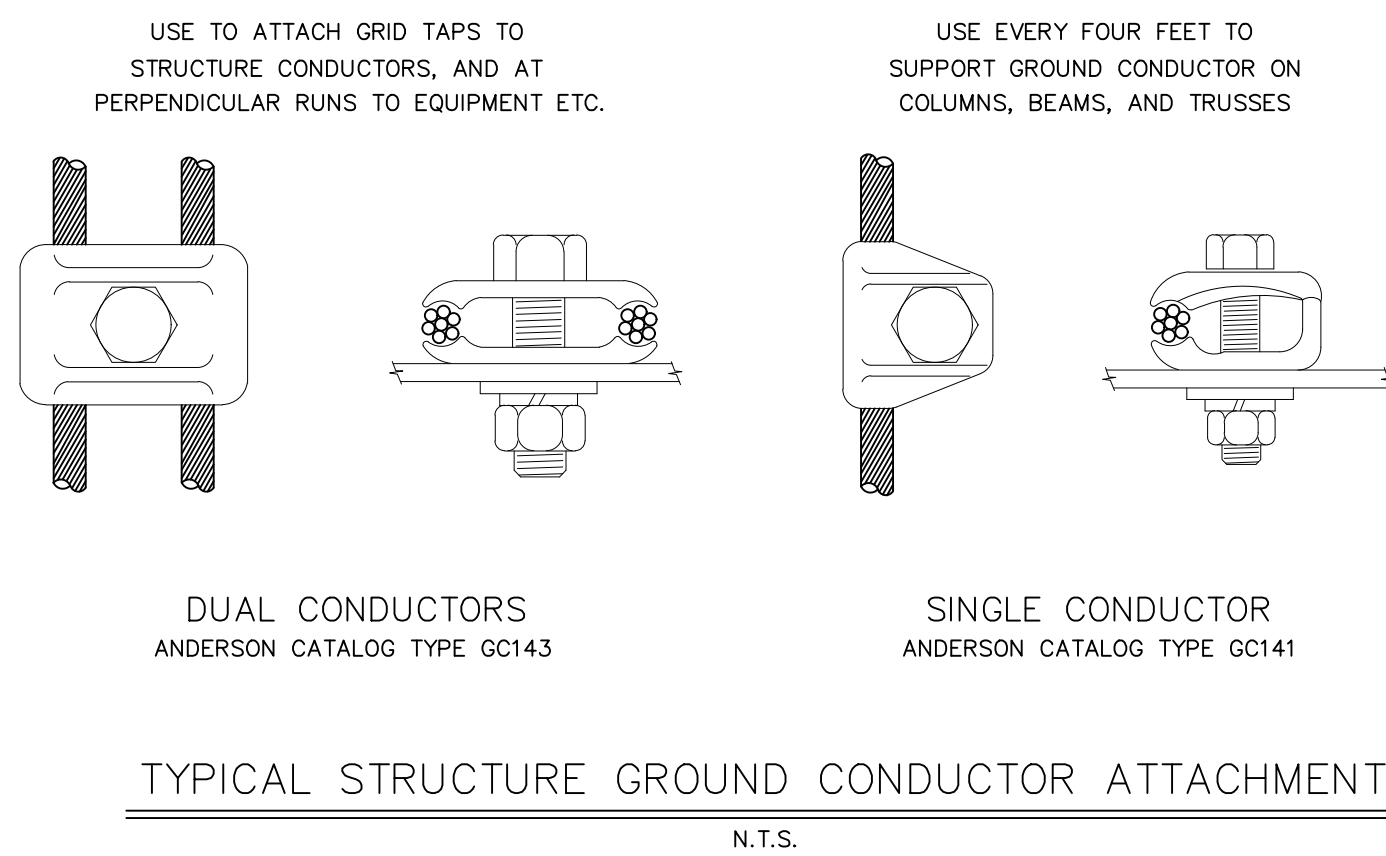
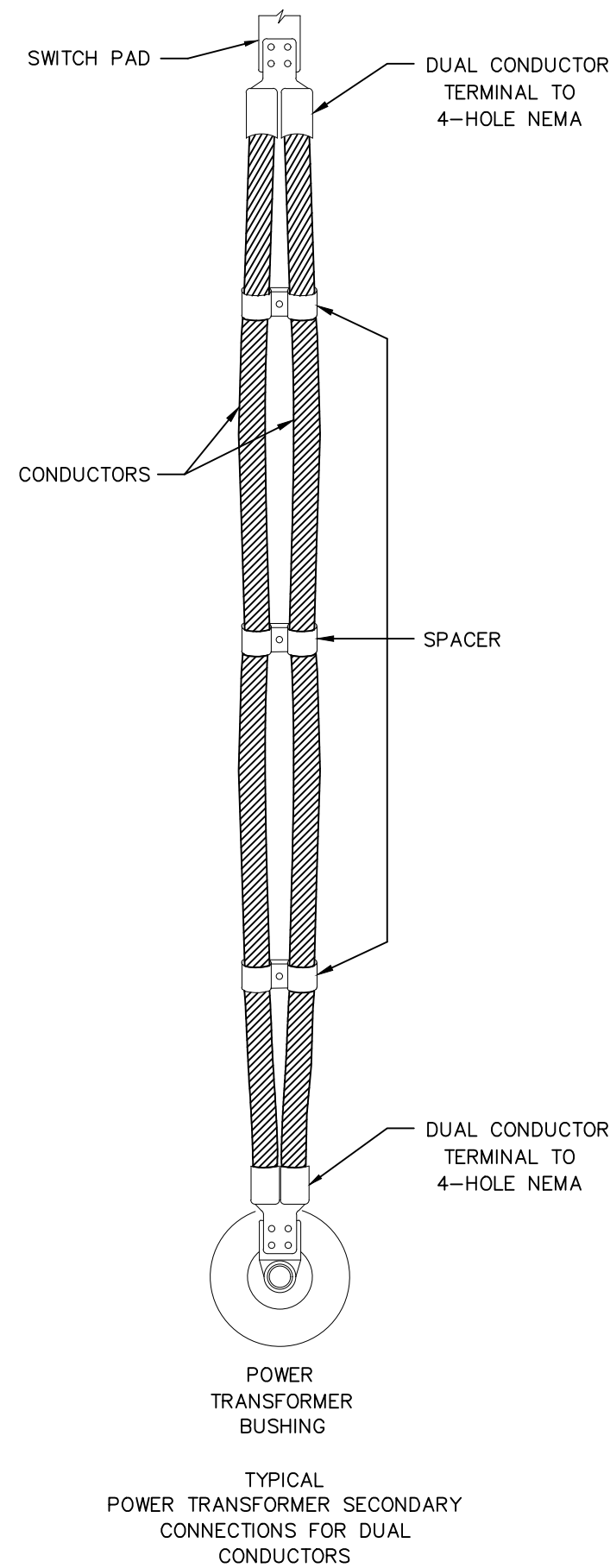
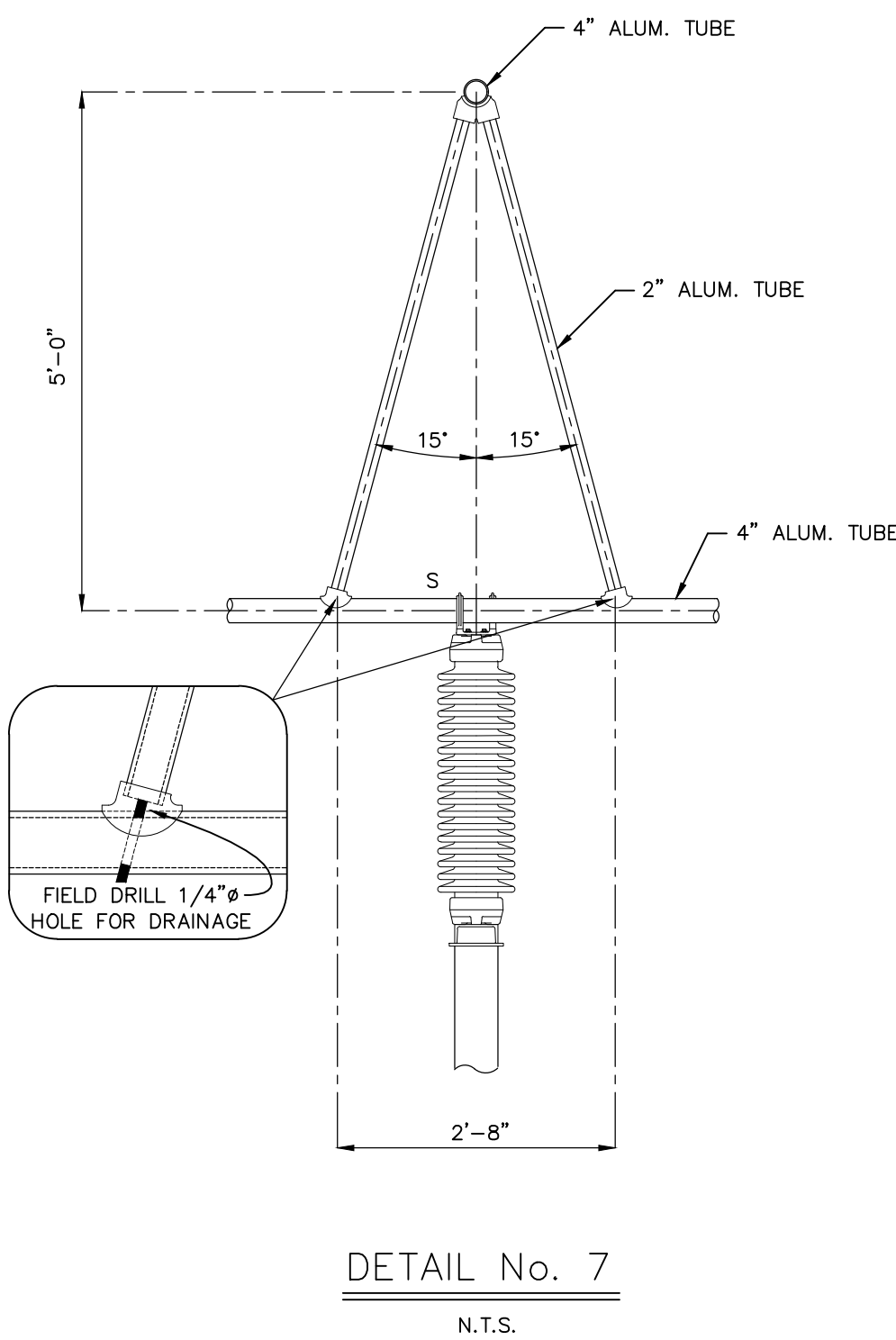
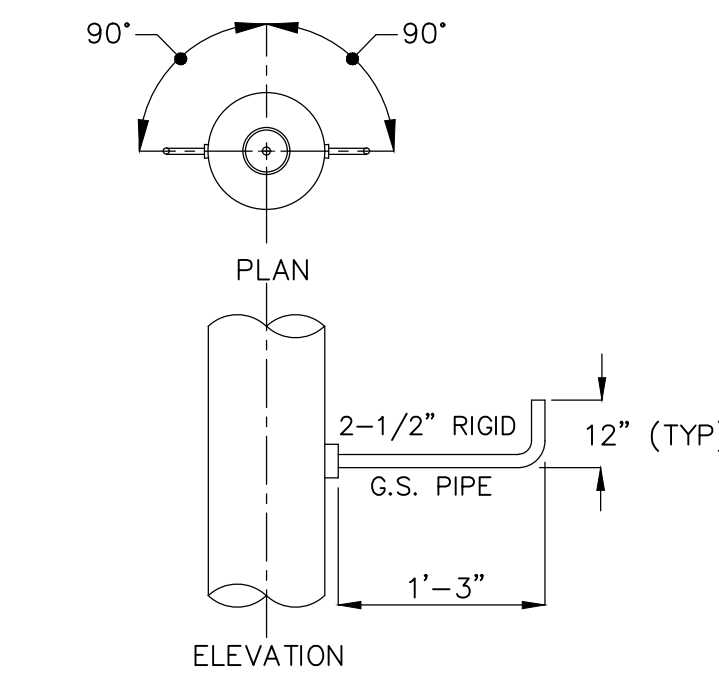
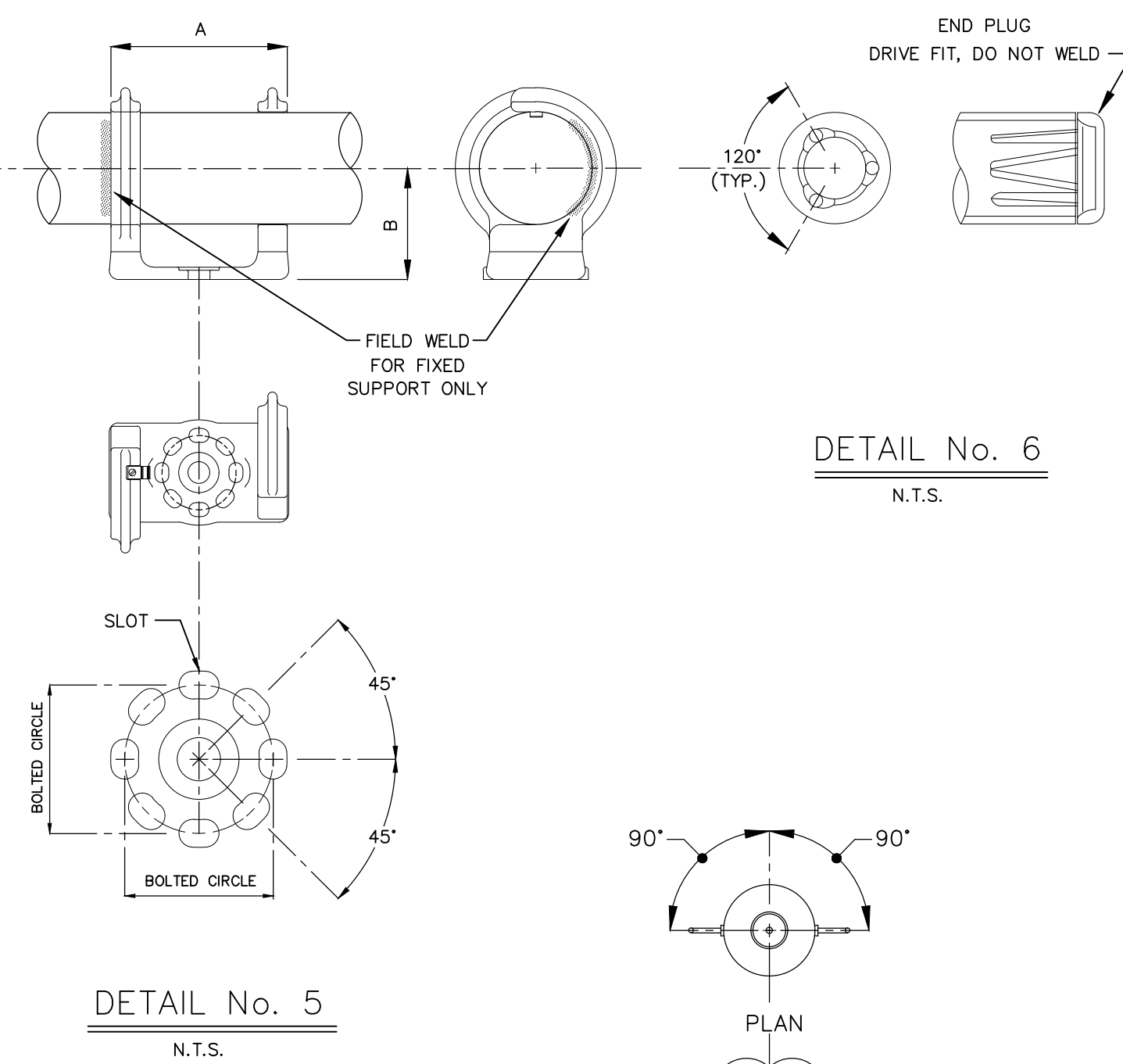
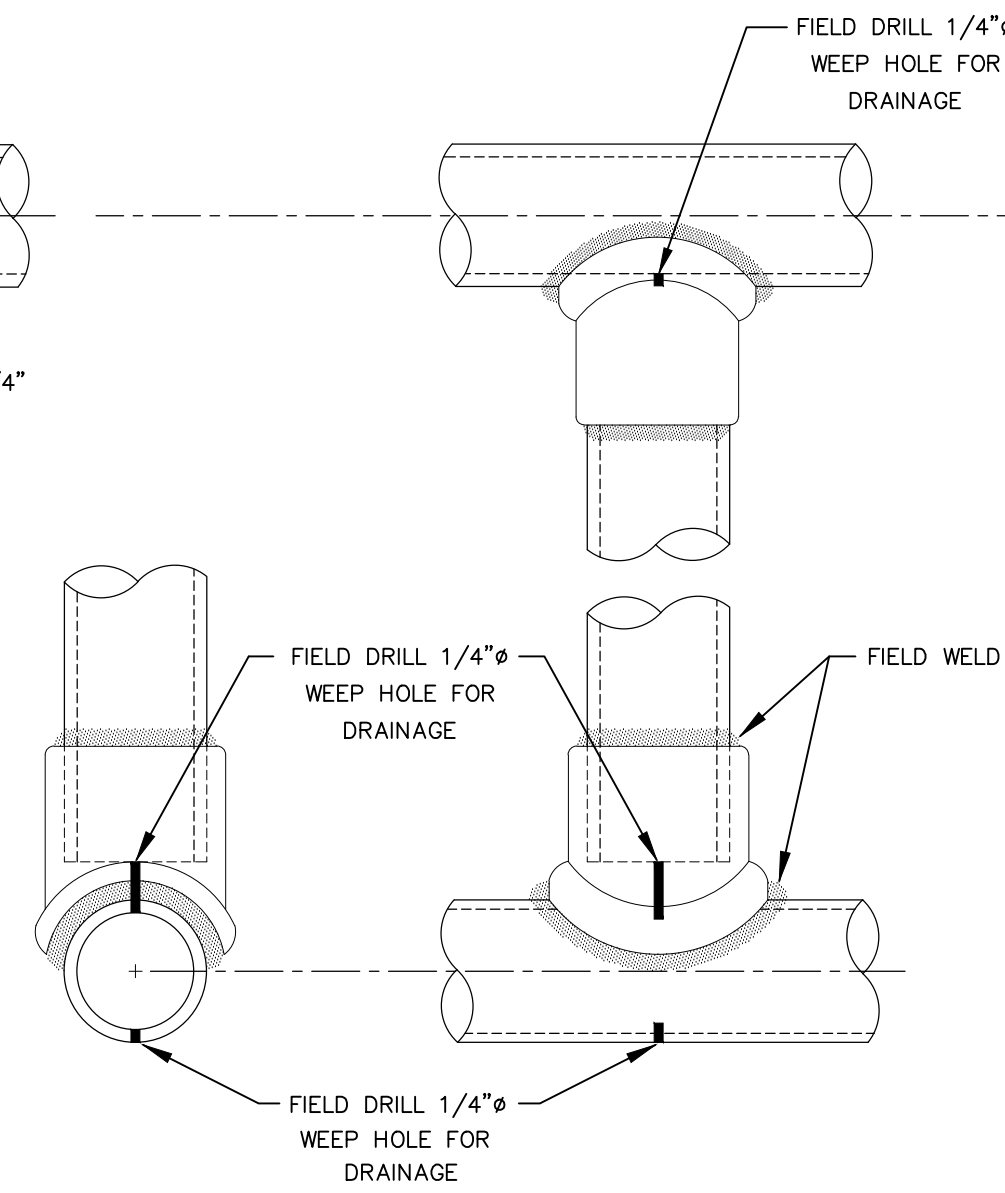
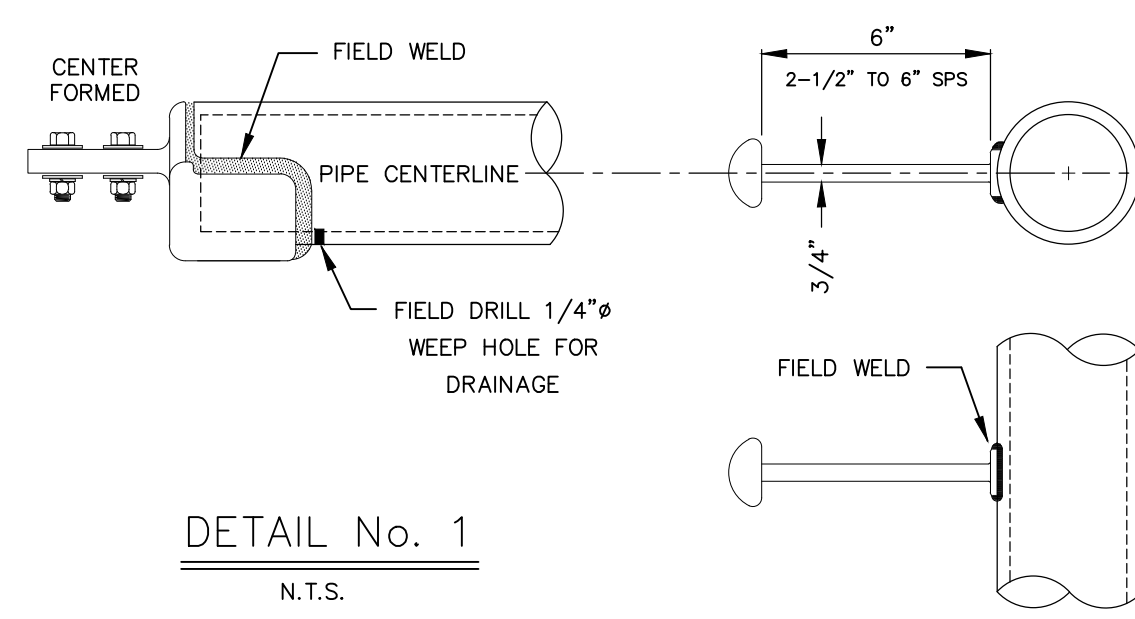

PRELIMINARY - DO NOT USE FOR CONSTRUCTION

© 03/2022

NO.	ISSUED FOR BID	REVISIONS	ENG.	DATE
A			BMJ	05/04/23

PROJECT NAME: CUMBERLAND ROAD 69 TO 15 X 25 KV SUBSTATION  
DRAWING TITLE: DETAILS

DRAWN BY:	JRT
CHECKED BY:	DAW
APPROVED BY:	MJW
DATE:	3/16/2022
SCALE:	NONE
FILE NUMBER:	12510
SHEET:	

GA5

NO.	ISSUED FOR BID	REVISIONS	ENG.	DATE
1	A		BJW	05/04/23

PROJECT NAME: **CUMBERLAND ROAD 69 TO 15 X 25 kV SUBSTATION**

DRAWING TITLE: **ONE LINE DIAGRAM**

DRAWN BY: JRT  
 CHECKED BY: DAW  
 APPROVED BY: MJW  
 DATE: 3/16/2022  
 SCALE: NTS  
 FILE NUMBER: 12513  
 SHEET: E01

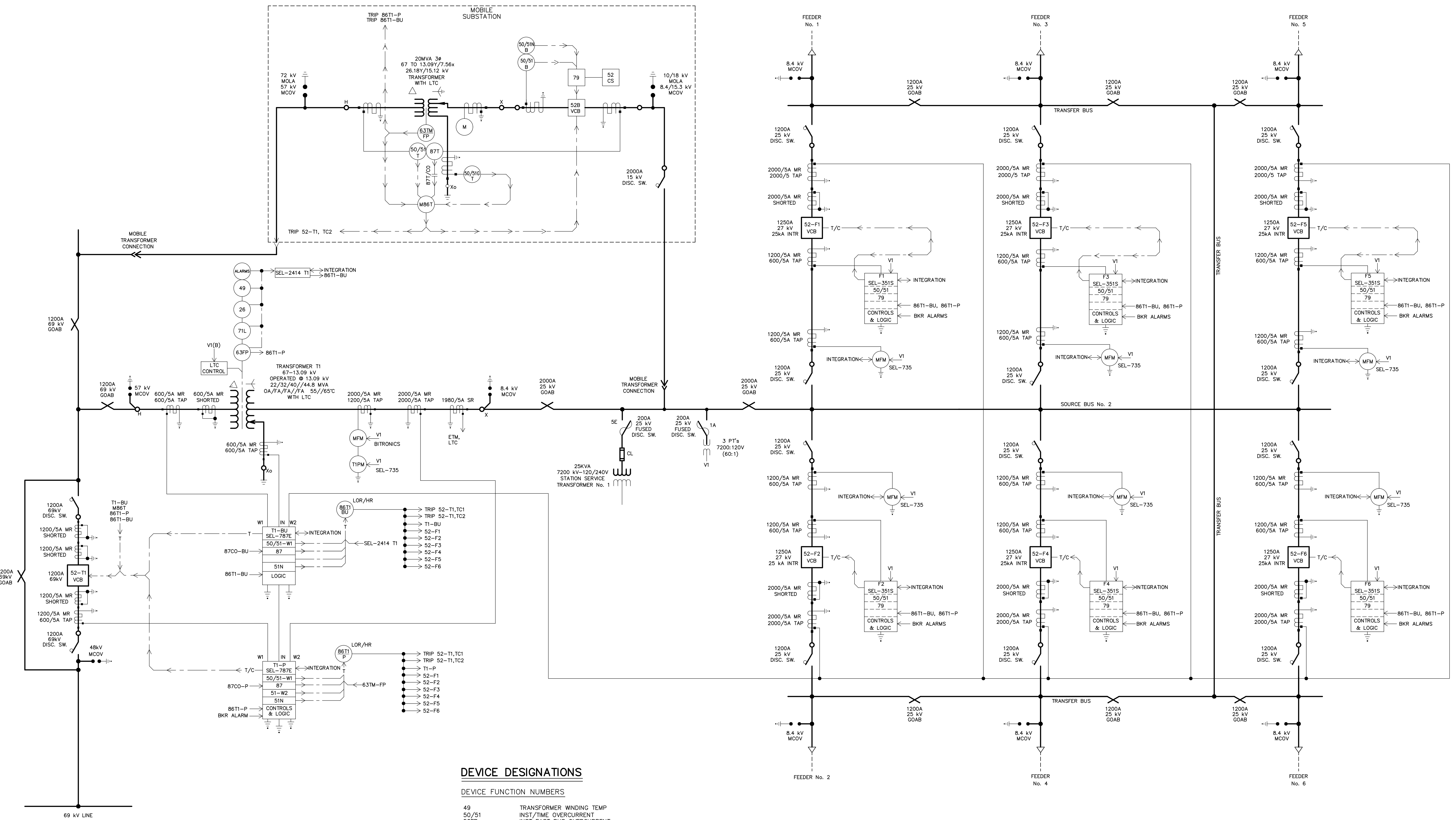

- ### DEVICE DESIGNATIONS
- #### DEVICE FUNCTION NUMBERS
- 49 TRANSFORMER WINDING TEMP
  - 50/51 INST TIME OVERCURRENT
  - 50FB INST FAST BUS OVERCURRENT
  - 52 AC CIRCUIT BREAKER
  - 52-P MULTIFUNCTION BREAKER RELAY
  - 63FP FAULT PRESSURE DEVICE/RELAY
  - 63TM-FP MOBILE SUB FAULT PRESSURE
  - 71 TRANSFORMER LIQUID LEVEL
  - 79 RECLOSING RELAY FUNCTION
  - 81 FREQUENCY RELAY FUNCTION
  - 86T1-P/-BU LOCKOUT RELAY-PRIMARY/BACKUP
  - 87 DIFFERENTIAL RELAY FUNCTION
  - 87CO DIFFERENTIAL CUTOFF
  - T1-P/T1-BU MULTIFUNCTION TRANSFORMER RELAYS
  - M86T MOBILE SUB LOR MULTI-FUNCTION
  - MFM METER
- #### SUFFIXES
- GCB GAS CIRCUIT BREAKER
  - GOAB GROUP OPERATED AIR BREAK
  - MOLA METALLIC OXIDE LIGHTNING ARRESTER
  - MCOV MAXIMUM CONTINUOUS OPERATING VOLTAGE
  - VCB VACUUM CIRCUIT BREAKER
- #### LETTER CODES
- V1 RELAY POTENTIAL - 15kV

- ### NOTES:
- BREAKER CONTROLS PERFORMED BY SEL-351S PUSHBUTTONS
  - DIFFERENTIAL CUT-OFFS (87CO) PERFORMED BY CONTROL SWITCHES ON RELAY PANEL
  - OTHER CONTROL SWITCH FUNCTIONS (71L-CO, 26/49-CO; etc.) PERFORMED BY LOCAL BITS IN T1-P & T1-BU RELAYS.

- ### LEGEND
- HIGH VOLTAGE CIRCUITS
  - LOW VOLTAGE CIRCUITS
  - ⤵ UNDERGROUND FEEDER EXIT
  - ➔ DIRECTION OF RELAY ACTION

NO.	ISSUED FOR BID	REVISIONS	ENG.	DATE
A			EWJ	05/04/23

PROJECT NAME: **CUMBERLAND ROAD TO 15 X 25 KV SUBSTATION**  
DRAWING TITLE: **GROUNDING PLAN**

DRAWN BY:	JRT
CHECKED BY:	DAW
APPROVED BY:	MJW
DATE:	3/16/2022
SCALE:	3/32"=1'-0"
FILE NUMBER:	12510
SHEET:	

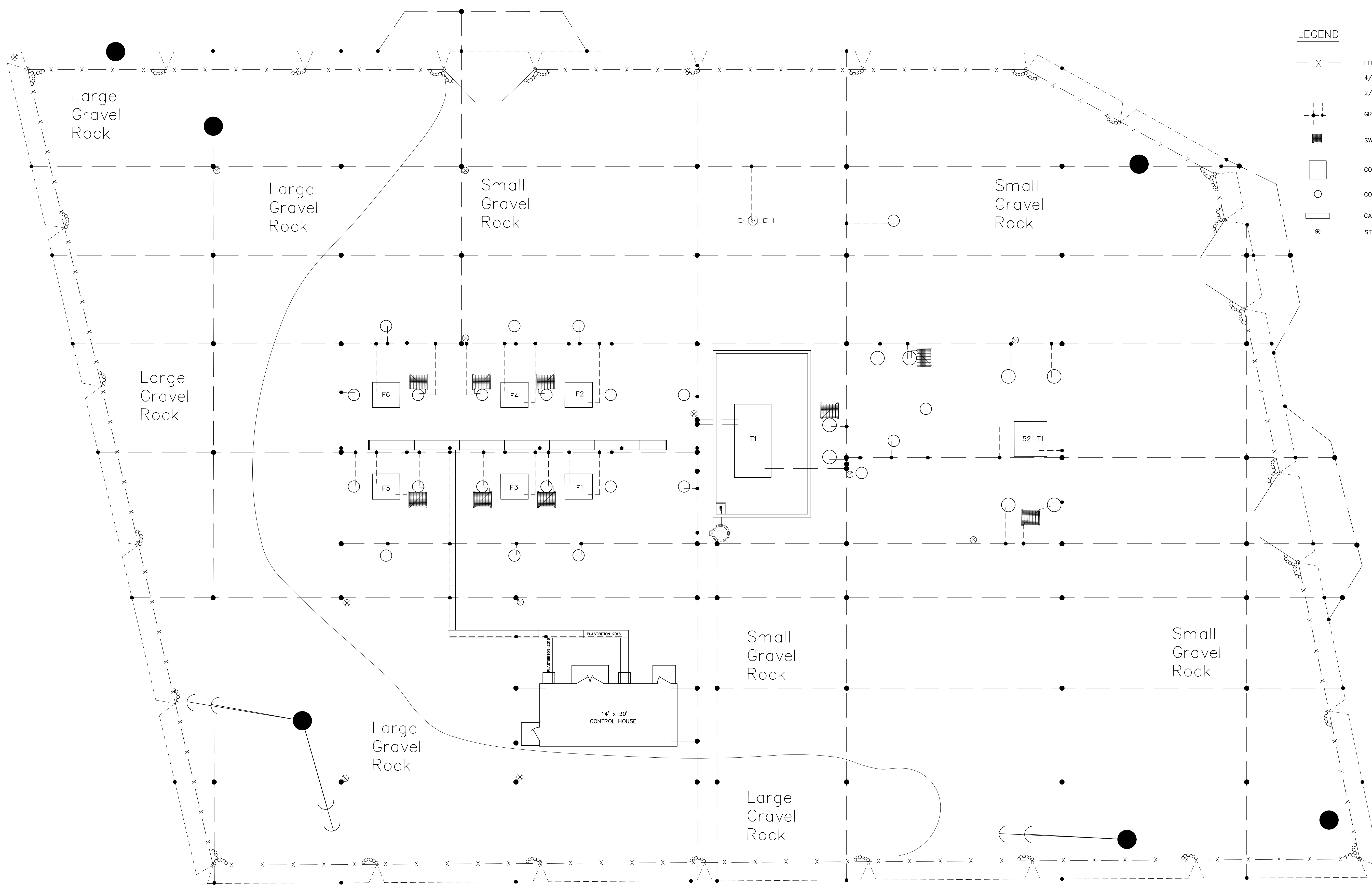

- LEGEND**
- X FENCE
  - 4/0 AWG. S.D. BARE COPPER
  - - - 2/0 AWG. S.D. BARE COPPER
  - GRID CONNECTORS: CADWELD TYPE
  - SWITCH OPERATOR PLATFORM
  - CONCRETE PAD
  - CONCRETE PIER
  - ▭ CABLE TRENCH
  - ⊙ STATIC POLE

**GROUNDING NOTES:**

1. ALL APPARATUS (TRANSFORMERS, REGULATORS, CIRCUIT BREAKERS, ETC.) SHALL HAVE TWO SEPARATE CONNECTIONS TO GROUND GRID.
2. TRANSFORMER CONNECTIONS TO THE GROUND GRID SHALL BE PARALLEL 4/0 AWG BARE COPPER.
3. GROUND GRID SHALL BE BURIED A MINIMUM OF 36" BELOW FINISHED SUBSTATION GRADE.
4. FINISHED SUBSTATION GRADE INCLUDES 3" WASHED STONE AND 3" OF CRUSHER RUN ABOVE SUBGRADE.
5. LOCATE ALL UNDERGROUND FACILITIES (DUCT BANKS, TRENCH, CONTROL OR POWER CABLES, ETC.) BEFORE INSTALLING GRID CONDUCTORS. COORDINATE CONSTRUCTION WITH BELOW GRADE UTILITIES.
6. SWITCH OPERATOR PLATFORMS SHALL BE LOCATED ON THE SAME SIDE OF SWITCH AS OPERATING HANDLE.
7. TEST EACH GROUND ROD PRIOR TO CONNECTION TO THE GROUND GRID. EACH 30' GROUND ROD SHOULD READ 100 OHMS OR LESS. IF THE READING EXCEEDS THIS VALUE CONTACT THE ENGINEER.
8. TEST THE GROUND GRID SYSTEM BEFORE ENERGIZING THE SUBSTATION AND WHILE ISOLATED FROM TRANSMISSION OR DISTRIBUTION SYSTEM(S). IF THE READING EXCEEDS 5.5 OHMS, CONTACT THE ENGINEER.
9. GROUND GRID MUST BE INSTALLED BEFORE THE OIL CONTAINMENT SYSTEM.
10. INSTALL GROUND GRID BEFORE INSTALLING CABLE TRENCH. COORDINATE CONSTRUCTION EFFORTS.
11. INSTALL 2/0 AWG. CU. GROUND ALONG LENGTH OF ALL TRENCH. SUPPORT GROUND AT TOP OF TRENCH INSIDE WALL. BOND TO GROUND GRID AT EACH INTERSECTION.

**GROUNDING PLAN**  
SCALE: 3/32"=1'-0"

**REFERENCE:**

- SITE PLAN . . . . . 12510S1
- GROUNDING DETAILS . . . . . 12510G2
- CONDUIT PLAN . . . . . 12510C1
- FOUNDATION PLAN . . . . . 12510FP1

NO.	ISSUED FOR BID	REVISIONS	ENG.	DATE
A			EWJ	05/04/23

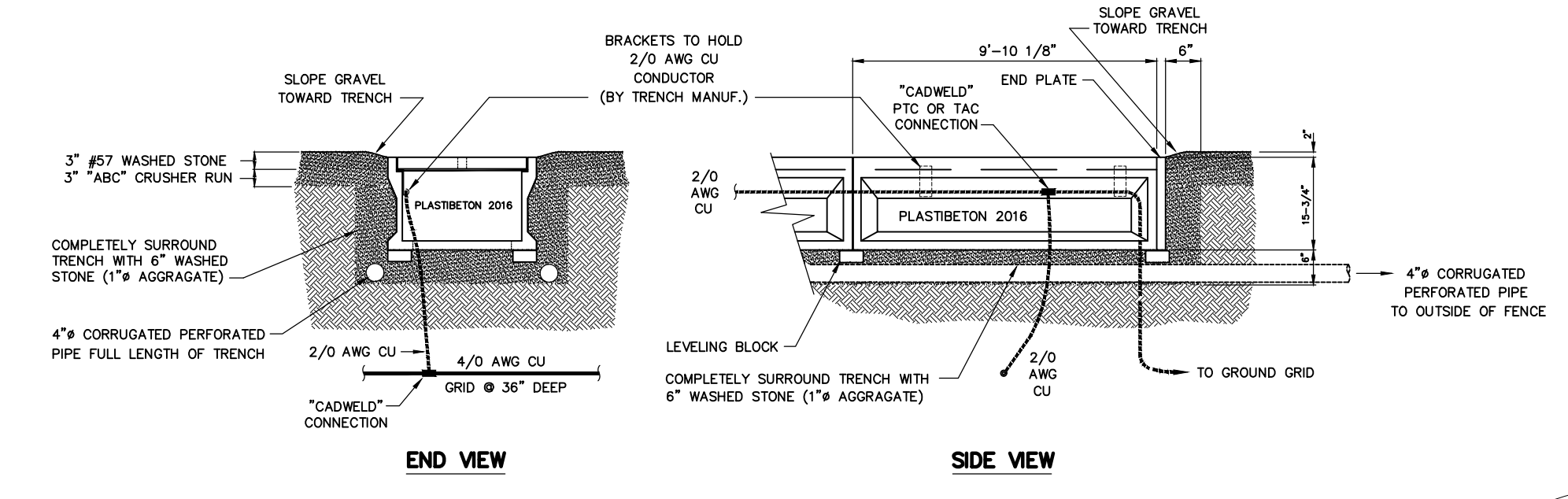

**TYPICAL TRENCH GROUNDING DETAIL**  
N.T.S.

INSTALL 2/0 GROUND ALONG LENGTH OF ALL TRENCH SUPPORTED BY GROUND CLIPS BETWEEN EACH SIDEWALL JOINT AND TRENCH BRACKET. BOND 2/0 TO GROUND GRID AT EACH INTERSECTION ALONG LENGTH OF TRENCH.

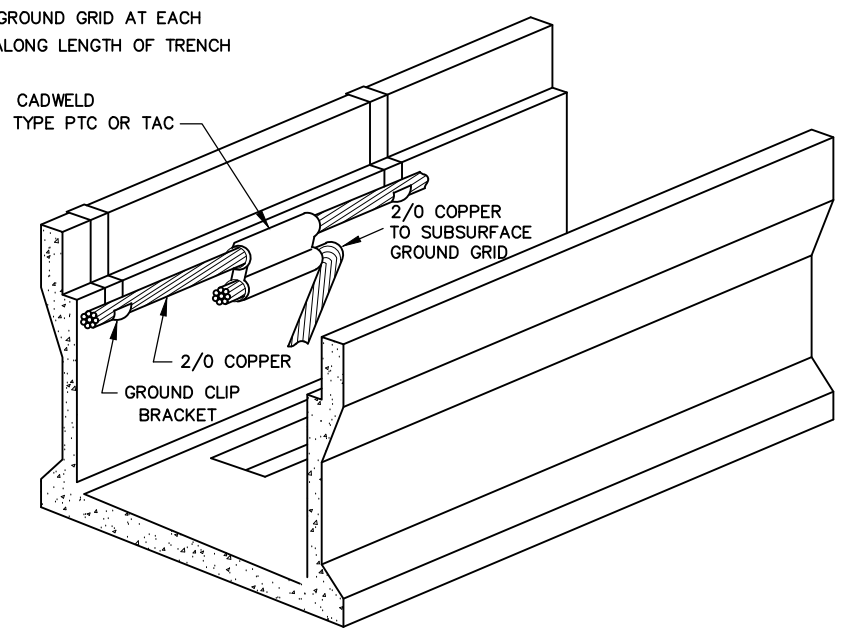

**GROUND CLIP DETAIL**  
N.T.S.

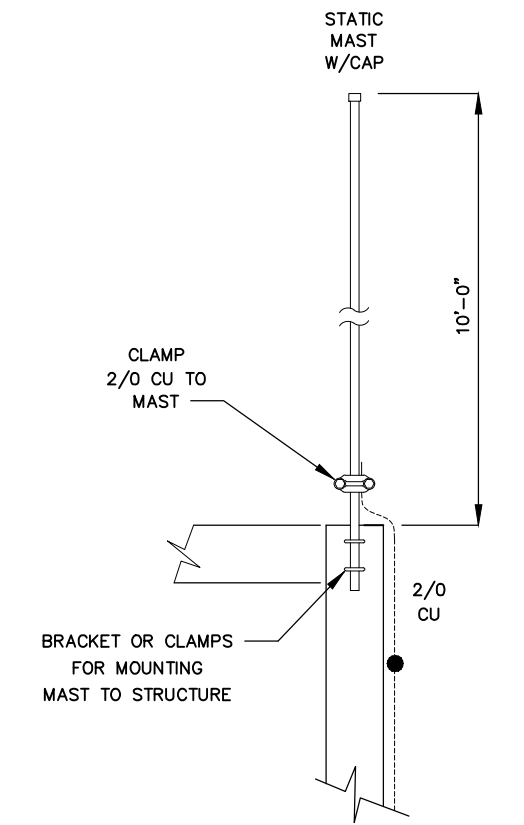

**TYPICAL STATIC MAST**  
N.T.S.

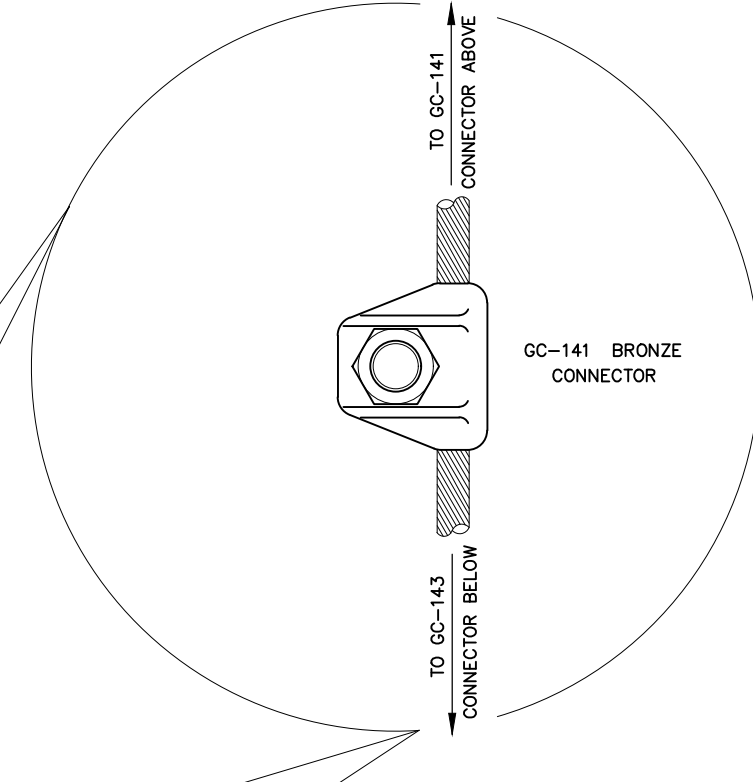

**25KV BREAKER GROUNDING DETAIL**  
N.T.S.

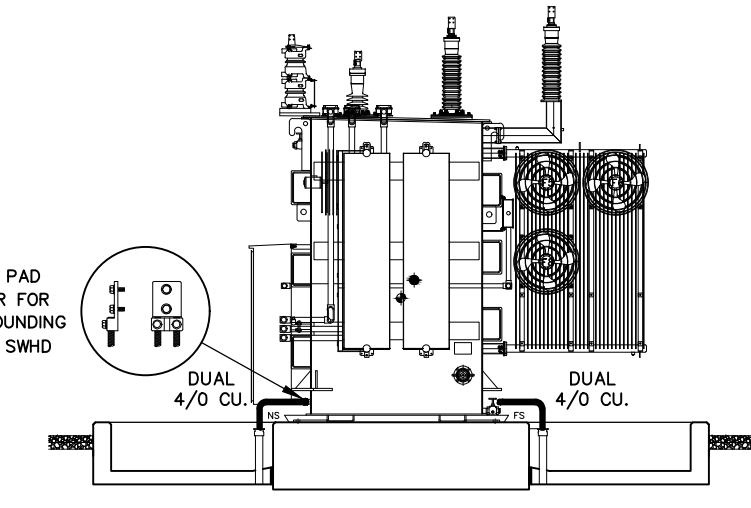

**POWER TRANSFORMER GROUNDING DETAIL**  
N.T.S.

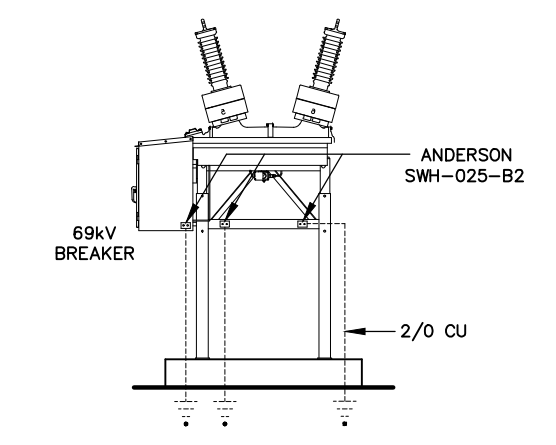

**69KV BREAKER GROUNDING DETAIL**  
N.T.S.

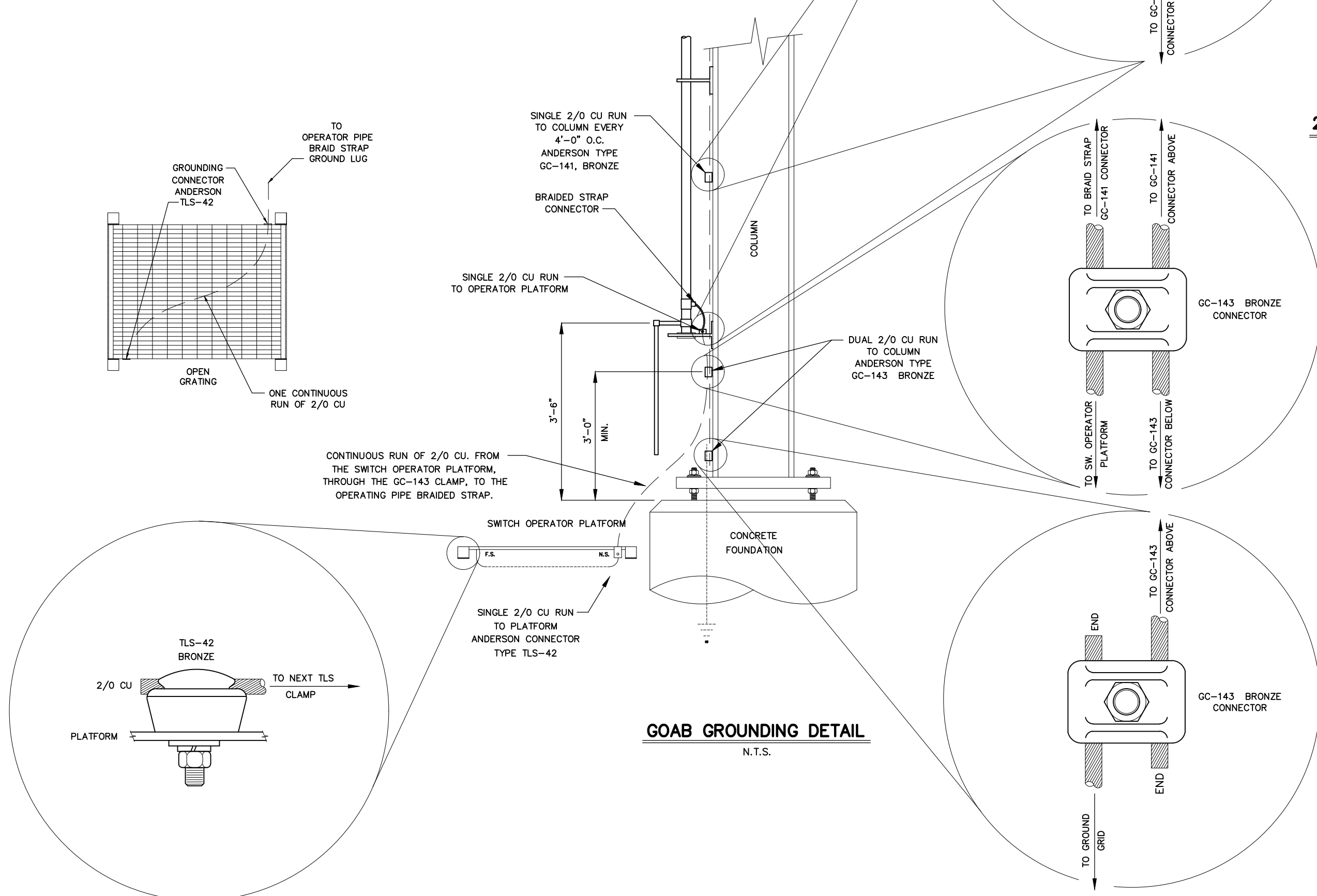

**GOAB GROUNDING DETAIL**  
N.T.S.

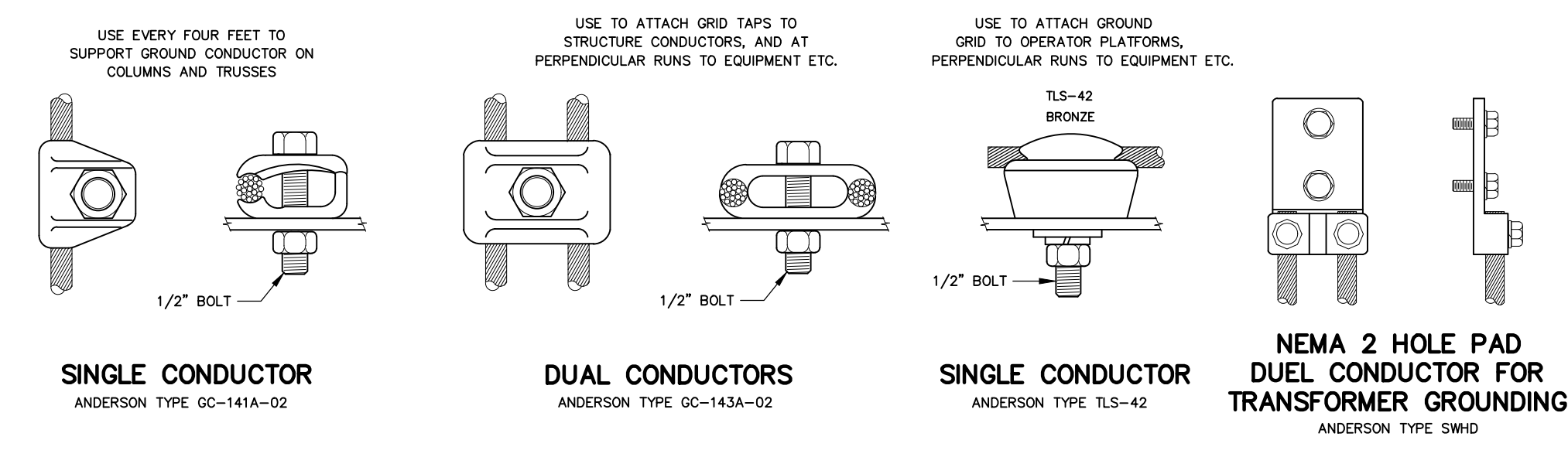

**TYPICAL STRUCTURE GROUND CONDUCTOR ATTACHMENT**  
N.T.S.

PROJECT NAME: CUMBERLAND ROAD 69 TO 15 X 25 KV SUBSTATION

DRAWING TITLE: GROUNDING DETAILS

DRAWN BY:	JRT
CHECKED BY:	DAW
APPROVED BY:	MJW
DATE:	3/16/2022
SCALE:	NTS
FILE NUMBER:	12510
SHEET:	



- NOTES:  
 1) ASTM 325 ERECTION BOLTS  
 2) ALL HOT DIP GALVANIZED AFTER FABRICATION (ASTM A123)  
 3) ALL HOLES 11/16" DIA. FOR 5/8" DIA. BOLTS UNLESS NOTED  
 4) PIECE MARK STAMPED INTO METAL WITH NOT LESS THAN 3/8" HIGH CHARACTERS BEFORE GALVANIZING  
 5) ALL WELDING ELECTRODES SHALL BE E7021  
 6) EDGE DISTANCE 1" UNLESS NOTED

BILL OF MATERIAL				
POS. NO.	QTY	DESC.	LENGTH	WEIGHT
<b>G120</b>	<b>2</b>	<b>FOR ONE GROUP G120</b>		
ANG157	4	L3x3x1/2	4"	12.53
B120	1	W6x15	15'-10 1/4"	237.81
BLACK WEIGHT:				250.34 LBS.
GALVANIZED WEIGHT:				10.01 LBS.
TOTAL WEIGHT:				260.35 LBS.

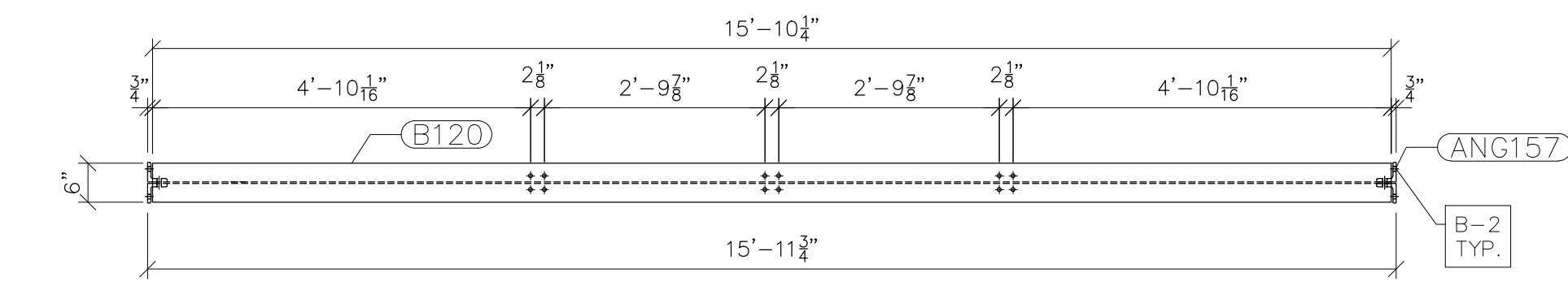

TOP VIEW

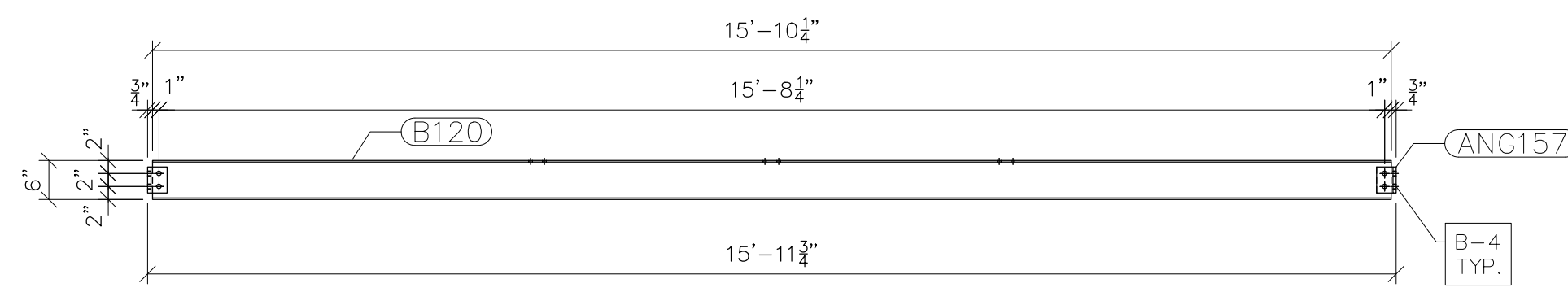

FRONT VIEW

G120  
SCALE: 1/2"=1'-0"

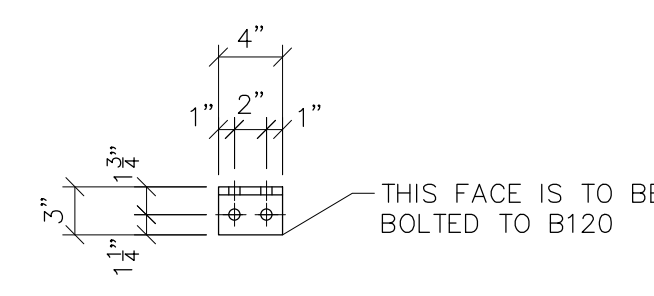

TOP VIEW

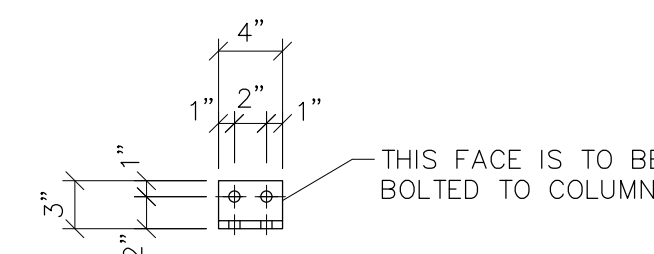

FRONT VIEW

ANG157  
SCALE: 1"=1'-0"



PRELIMINARY -  
DO NOT USE FOR  
CONSTRUCTION

© 05/2023

NO.	ISSUED FOR BID	REVISIONS	ENG.	DATE
A			VK	06/10/2023

PROJECT NAME: CUMBERLAND ROAD  
69 TO 15 X 25 kV  
SUBSTATION

DRAWING TITLE:  
LOW SIDE DETAILS (TRUSSES)

DRAWN BY:	DJD
CHECKED BY:	VK
APPROVED BY:	VK
DATE:	05/10/2023
SCALE:	AS SHOWN
FILE NUMBER:	12510
SHEET:	

NOTE:  
SEE ED-3 FOR DETAILS



PRELIMINARY -  
DO NOT USE FOR  
CONSTRUCTION

© 05/2023

NO.	ISSUED FOR BID	REVISIONS	ENG.	DATE
A			VK	06/10/2023

PROJECT NAME: CUMBERLAND ROAD  
69 TO 15 X 25 kV  
SUBSTATION  
DRAWING TITLE:  
OVERALL ERECTION DIAGRAM

DRAWN BY:	DJD
CHECKED BY:	VK
APPROVED BY:	VK
DATE:	05/10/2023
SCALE:	AS SHOWN
FILE NUMBER:	12510
SHEET:	

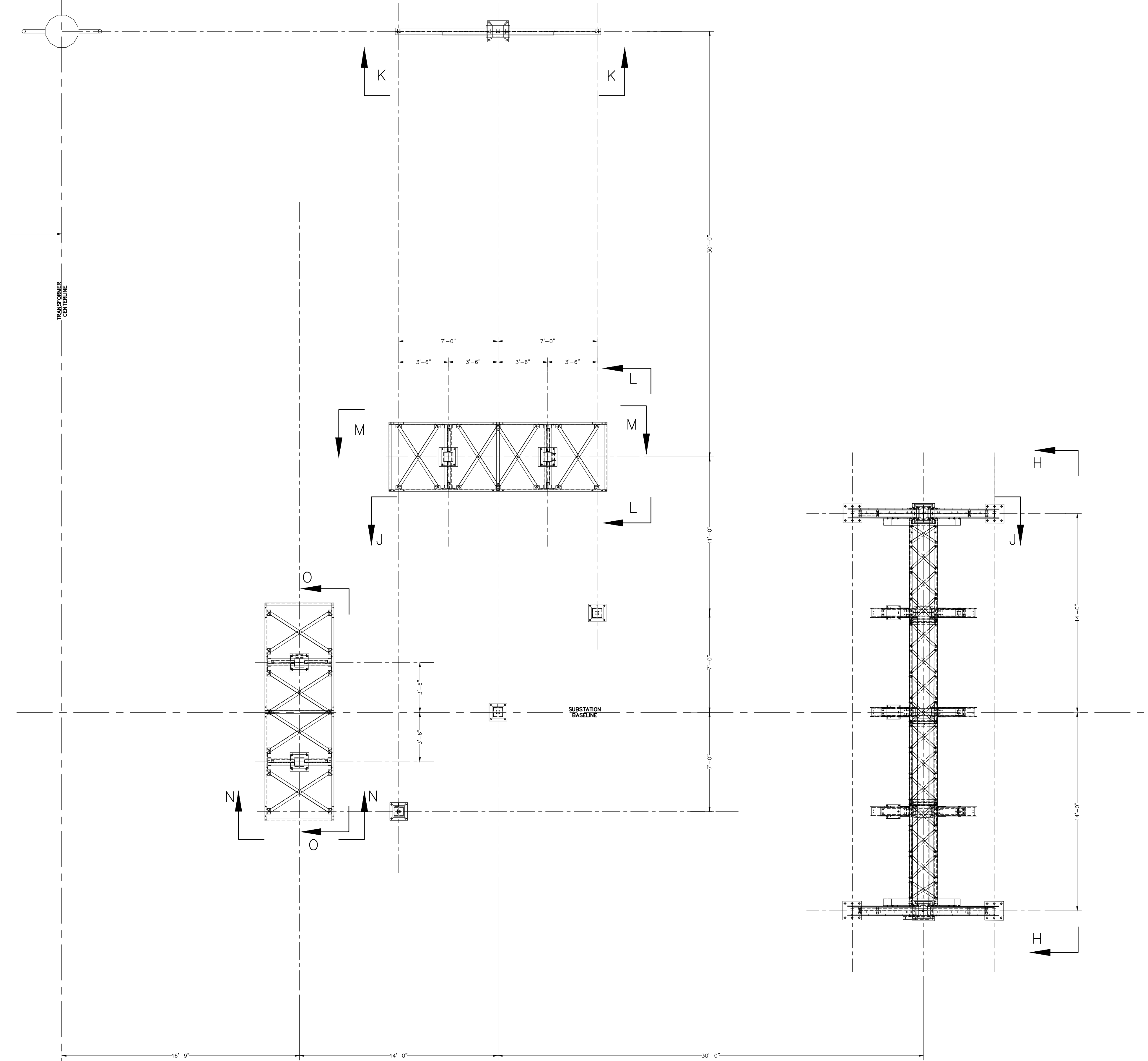

ERECTION PLAN VIEW  
SCALE: 1/4"=1'-0"

NOTE:  
SEE ED-4 FOR DETAILS

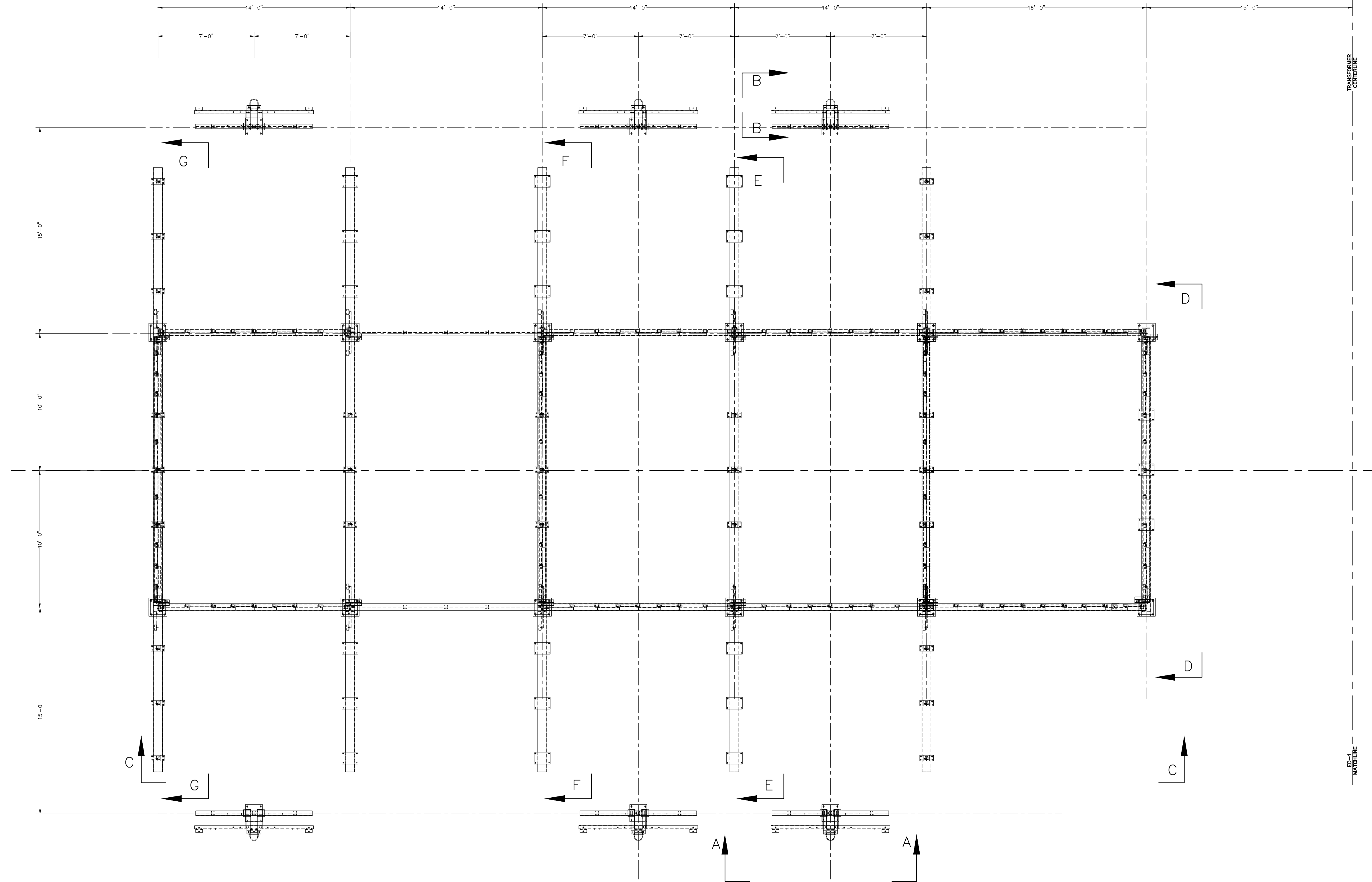

ERECTION PLAN VIEW  
SCALE: 1/4"=1'-0"



PRELIMINARY -  
DO NOT USE FOR  
CONSTRUCTION

© 05/2023

NO.	ISSUED FOR BID	REVISIONS	ENG.	DATE
A			VK	06/10/2023

PROJECT NAME: CUMBERLAND ROAD  
69 TO 15 X 25 KV  
SUBSTATION  
DRAWING TITLE:  
OVERALL ERECTION DIAGRAM

DRAWN BY:	DJD
CHECKED BY:	VK
APPROVED BY:	VK
DATE:	05/10/2023
SCALE:	AS SHOWN
FILE NUMBER:	12510
SHEET:	

NOYE:  
SEE ED-1 AND ED-2 FOR OVERALL SITE



PRELIMINARY -  
DO NOT USE FOR  
CONSTRUCTION

© 05/2023

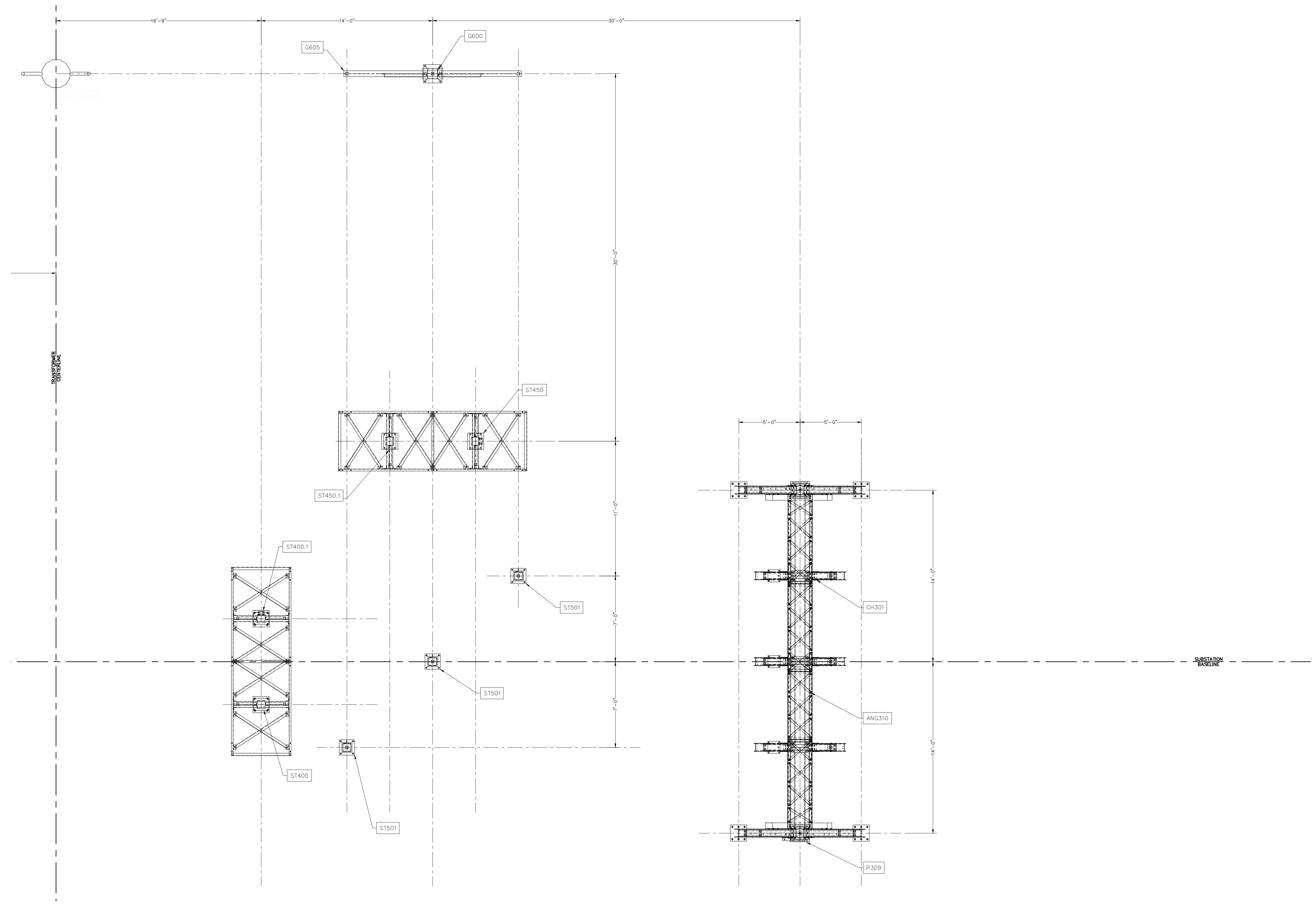

\* LABELS DENOTE GROUP DESIGNATIONS

ERECTION PLAN VIEW  
SCALE: 1/4"=1'-0"

NO.	ISSUED FOR BID	REVISIONS	ENG.	DATE
A			VK	06/10/2023

PROJECT NAME: CUMBERLAND ROAD  
69 TO 15 X 25 kV  
SUBSTATION

DRAWING TITLE:  
OVERALL ERECTION DIAGRAM

DRAWN BY:	DJD
CHECKED BY:	VK
APPROVED BY:	VK
DATE:	05/10/2023
SCALE:	AS SHOWN
FILE NUMBER:	12510
SHEET:	

NOTE:  
SEE ED-1 AND ED-2 FOR OVERALL SITE



PRELIMINARY -  
DO NOT USE FOR  
CONSTRUCTION

© 05/2023

NO.	REVISIONS	ENG.	DATE
A	ISSUED FOR BID	VK	06/10/2023

PROJECT NAME: CUMBERLAND ROAD  
69 TO 15 X 25 kV  
SUBSTATION

DRAWING TITLE:  
OVERALL ERECTION DIAGRAM

DRAWN BY:	DJD
CHECKED BY:	VK
APPROVED BY:	VK
DATE:	05/10/2023
SCALE:	AS SHOWN
FILE NUMBER:	12510
SHEET:	

ED-04

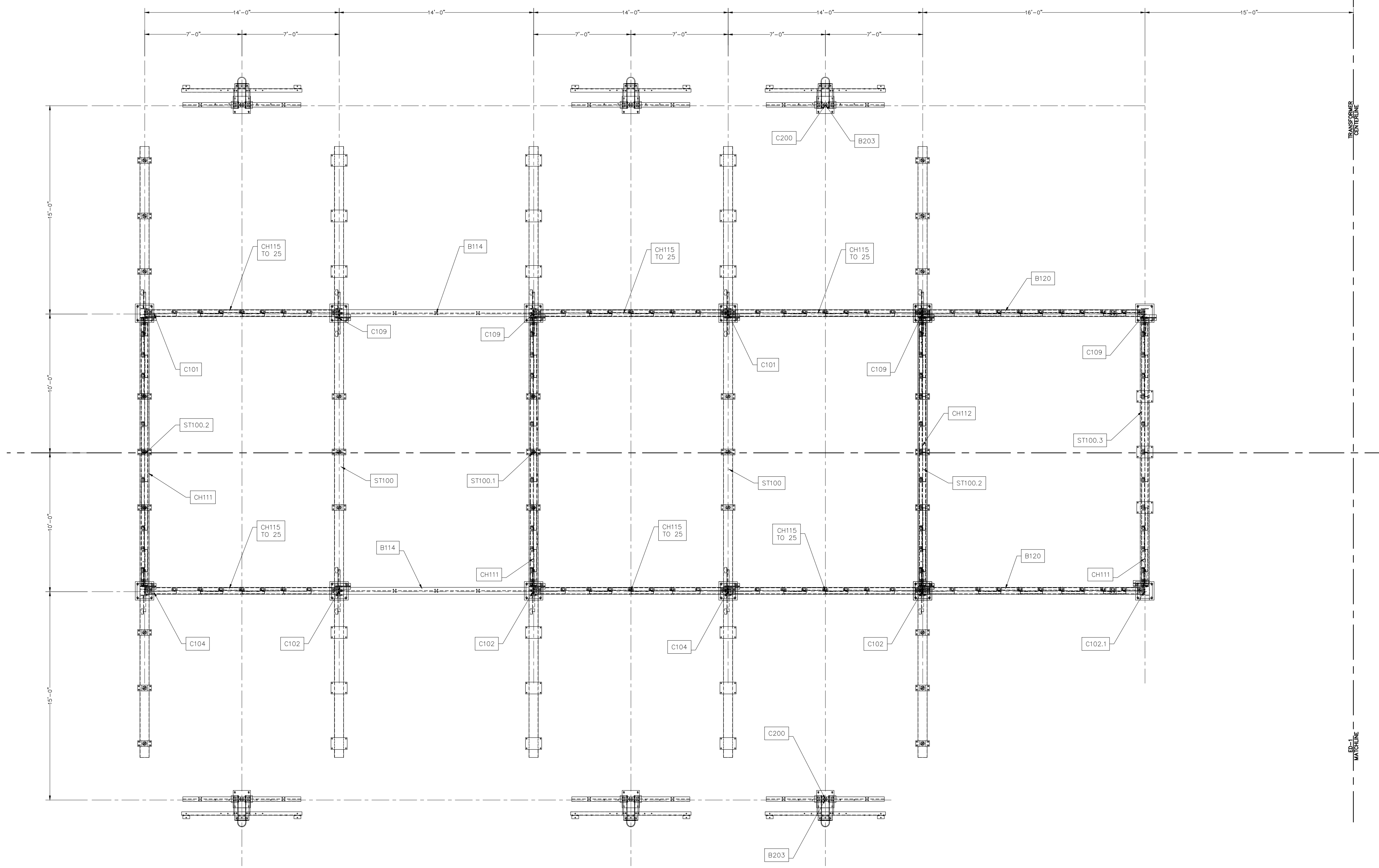

ERECTION PLAN VIEW  
SCALE: 1/4"=1'-0"  
\* LABELS DENOTE GROUP DESIGNATIONS

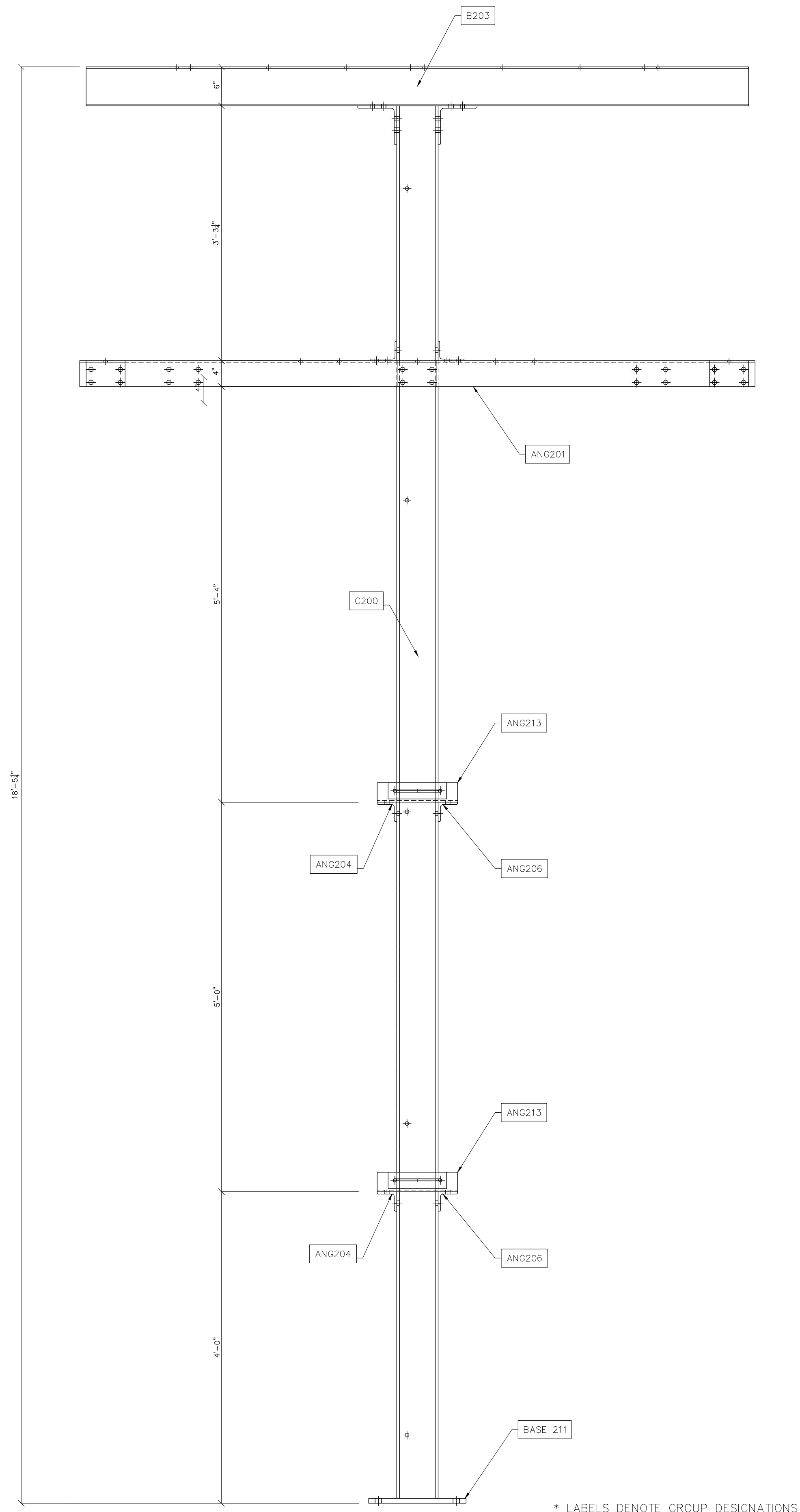

URD STAND SECTION A-A  
SCALE: N.T.S.

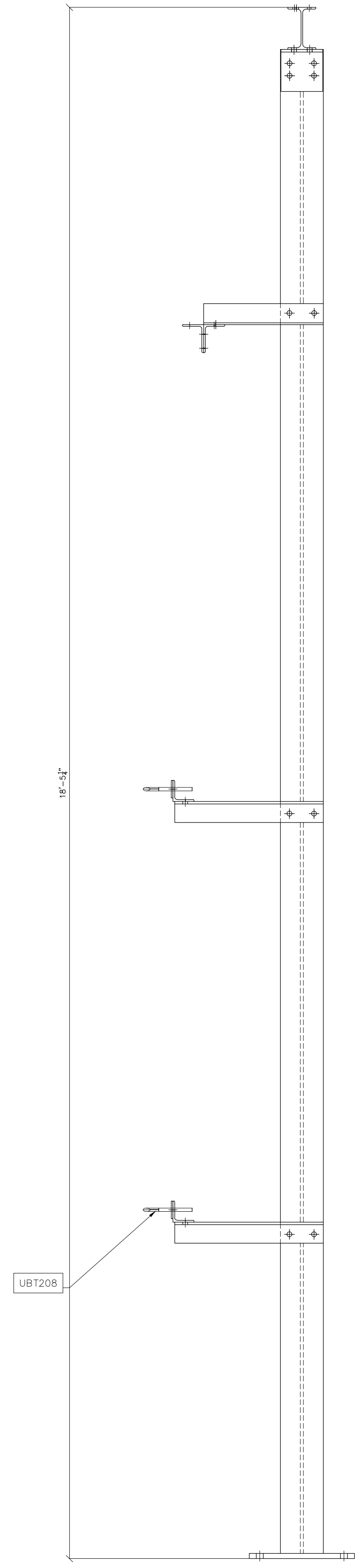

URD STAND SECTION B-B  
SCALE: N.T.S.

SEE "URD" SERIES OF DRAWINGS  
FOR URD STAND DETAILS

PRELIMINARY -  
DO NOT USE FOR  
CONSTRUCTION

© 05/2023

NO.	ISSUED FOR BID	REVISIONS	ENG.	DATE
A			VK	06/10/2023

PROJECT NAME: CUMBERLAND ROAD  
69 TO 15 X 25 kV  
SUBSTATION

DRAWING TITLE:  
OVERALL ERECTION DIAGRAM

DRAWN BY:	DJD
CHECKED BY:	VK
APPROVED BY:	VK
DATE:	05/10/2023
SCALE:	AS SHOWN
FILE NUMBER:	12510
SHEET:	

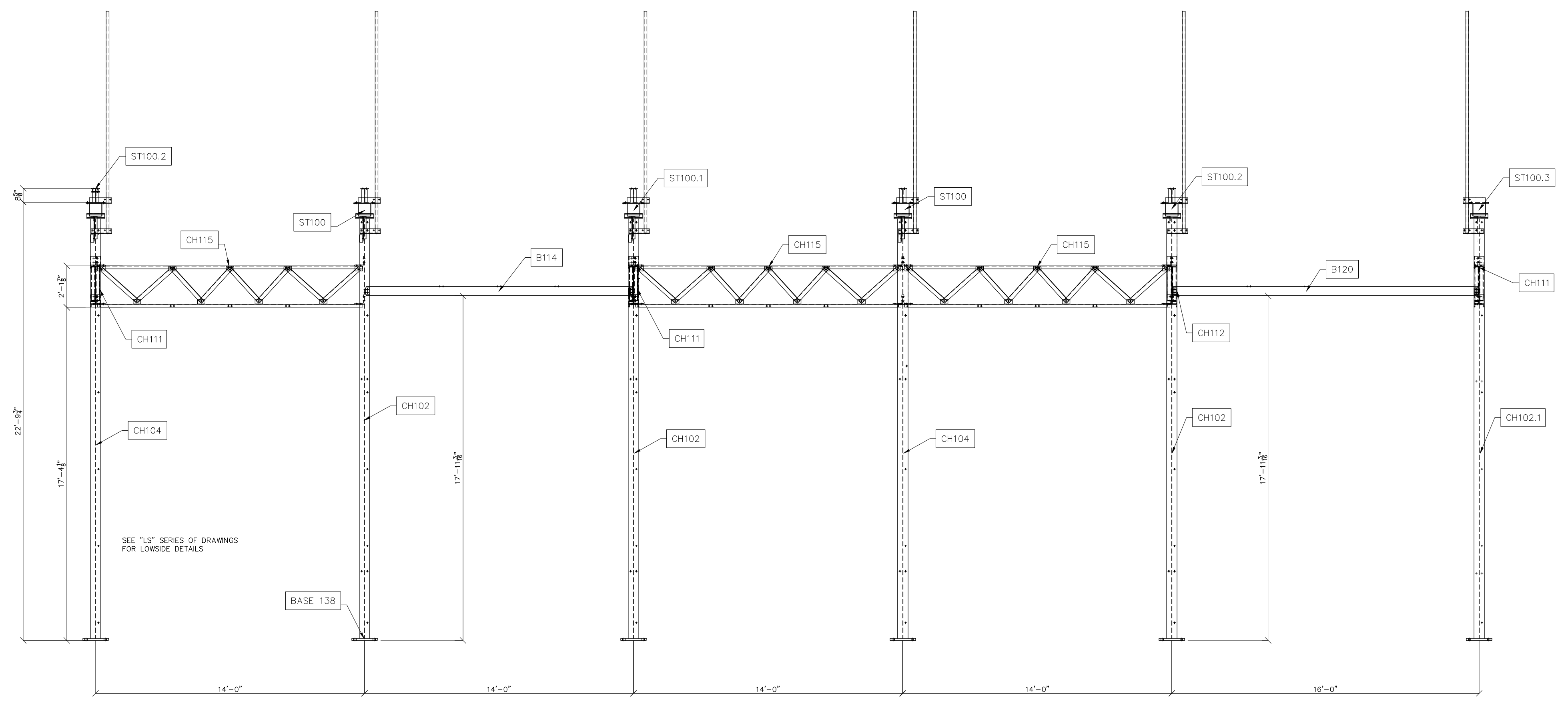

LOWSIDE SECTION C-C  
SCALE: N.T.S.

PRELIMINARY -  
DO NOT USE FOR  
CONSTRUCTION

© 05/2023

NO.	ISSUED FOR BID	REVISIONS	ENG.	DATE
A			VK	06/10/2023

PROJECT NAME: CUMBERLAND ROAD  
69 TO 15 X 25 kV  
SUBSTATION

DRAWING TITLE:  
OVERALL ERECTION DIAGRAM

DRAWN BY:	DJD
CHECKED BY:	VK
APPROVED BY:	VK
DATE:	05/10/2023
SCALE:	AS SHOWN
FILE NUMBER:	12510
SHEET:	

SEE "LS" SERIES OF DRAWINGS FOR LOWSIDE DETAILS

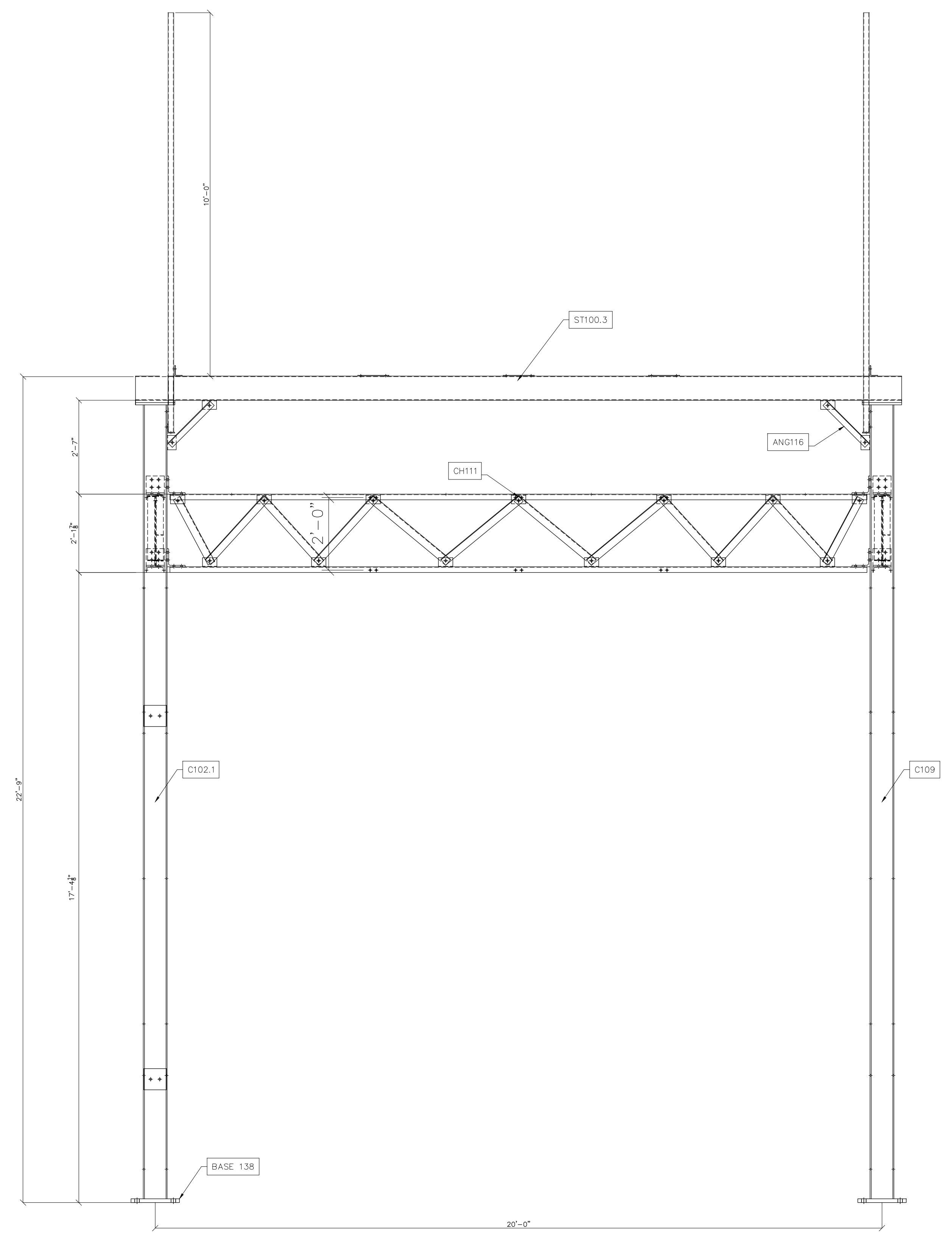

\* LABELS DENOTE GROUP DESIGNATIONS

LOWSIDE SECTION D-D  
SCALE: N.T.S.



PRELIMINARY -  
DO NOT USE FOR  
CONSTRUCTION

© 05/2023

NO.	ISSUED FOR BID	REVISIONS	ENG.	DATE
A			VK	06/10/2023

PROJECT NAME: CUMBERLAND ROAD  
69 TO 15 X 25 kV  
SUBSTATION

DRAWING TITLE:  
OVERALL ERECTION DIAGRAM

DRAWN BY:	DJD
CHECKED BY:	VK
APPROVED BY:	VK
DATE:	05/10/2023
SCALE:	AS SHOWN
FILE NUMBER:	12510
SHEET:	



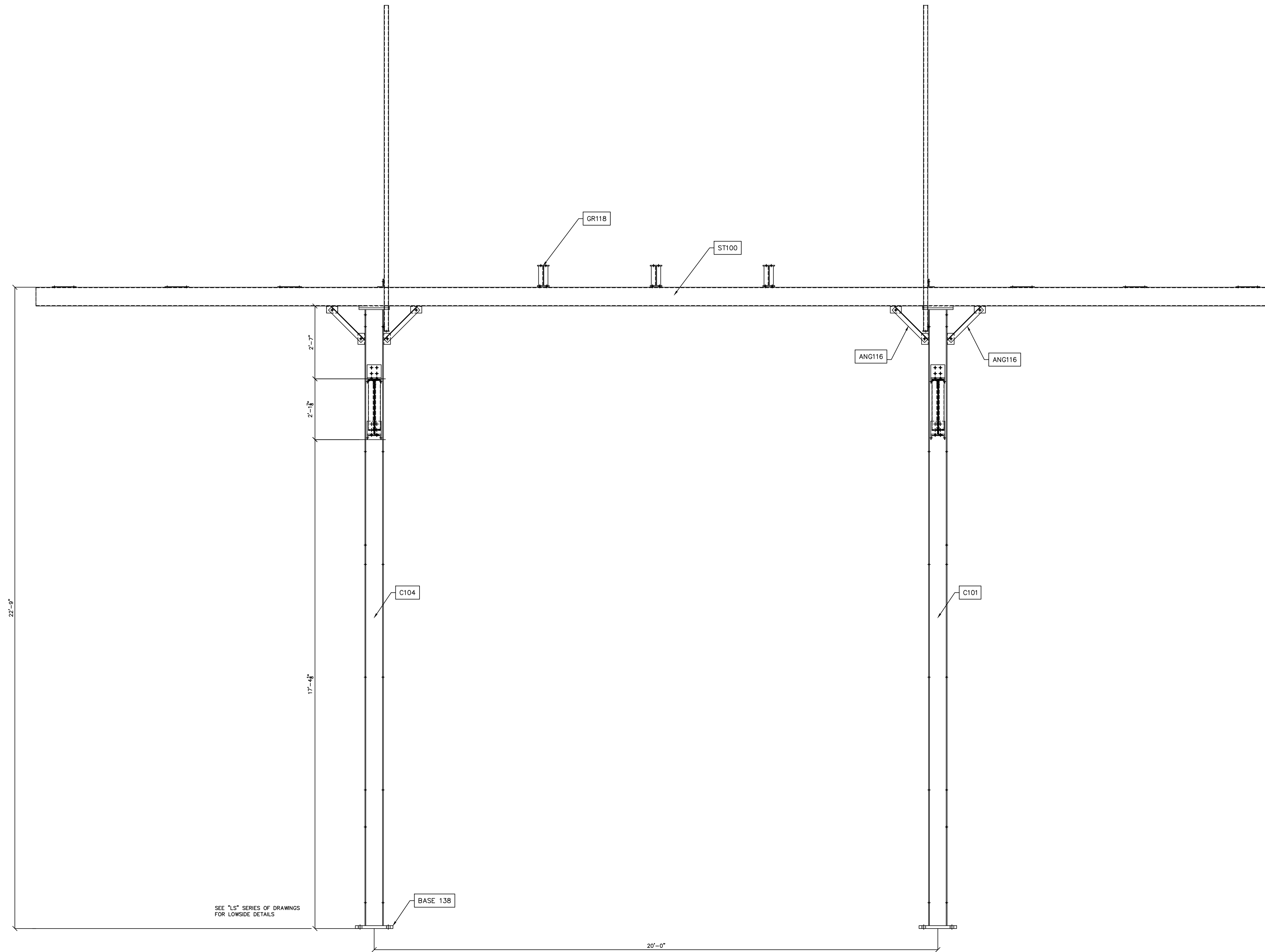

\* LABELS DENOTE GROUP DESIGNATIONS

LOWSIDE SECTION E-E  
SCALE: N.T.S.



PRELIMINARY -  
DO NOT USE FOR  
CONSTRUCTION

© 05/2023

NO.	ISSUED FOR BID	REVISIONS	ENG.	DATE
A			VK	06/10/2023

PROJECT NAME: CUMBERLAND ROAD  
69 TO 15 X 25 KV  
SUBSTATION

DRAWING TITLE:  
OVERALL ERECTION DIAGRAM

DRAWN BY:	DJD
CHECKED BY:	VK
APPROVED BY:	VK
DATE:	05/10/2023
SCALE:	AS SHOWN
FILE NUMBER:	12510
SHEET:	

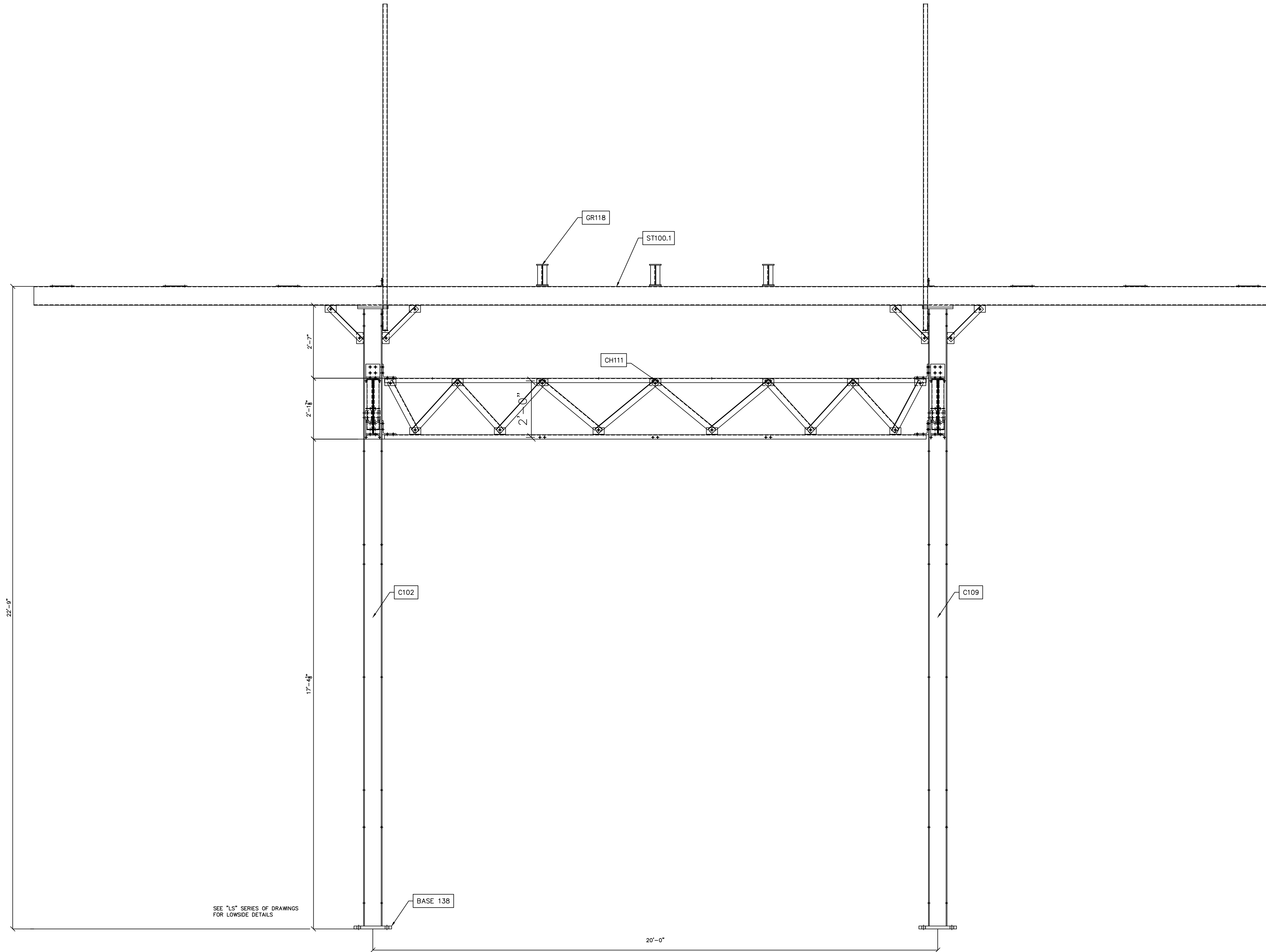

SEE "LS" SERIES OF DRAWINGS FOR LOWSIDE DETAILS

\* LABELS DENOTE GROUP DESIGNATIONS

LOWSIDE SECTION F-F  
SCALE: N.T.S



**Booth & Associates**  
2300 Rawwood Drive Suite 300, Raleigh, NC 27607  
N.C.F. 0221



**PRELIMINARY -  
DO NOT USE FOR  
CONSTRUCTION**

© 05/2023

NO.	ISSUED FOR BID	REVISIONS	ENG.	DATE
A			VK	06/10/2023

PROJECT NAME: CUMBERLAND ROAD  
69 TO 15 X 25 KV  
SUBSTATION  
DRAWING TITLE:  
**OVERALL ERECTION DIAGRAM**

DRAWN BY:	DJD
CHECKED BY:	VK
APPROVED BY:	VK
DATE:	05/10/2023
SCALE:	AS SHOWN
FILE NUMBER:	12510
SHEET:	

ED-09

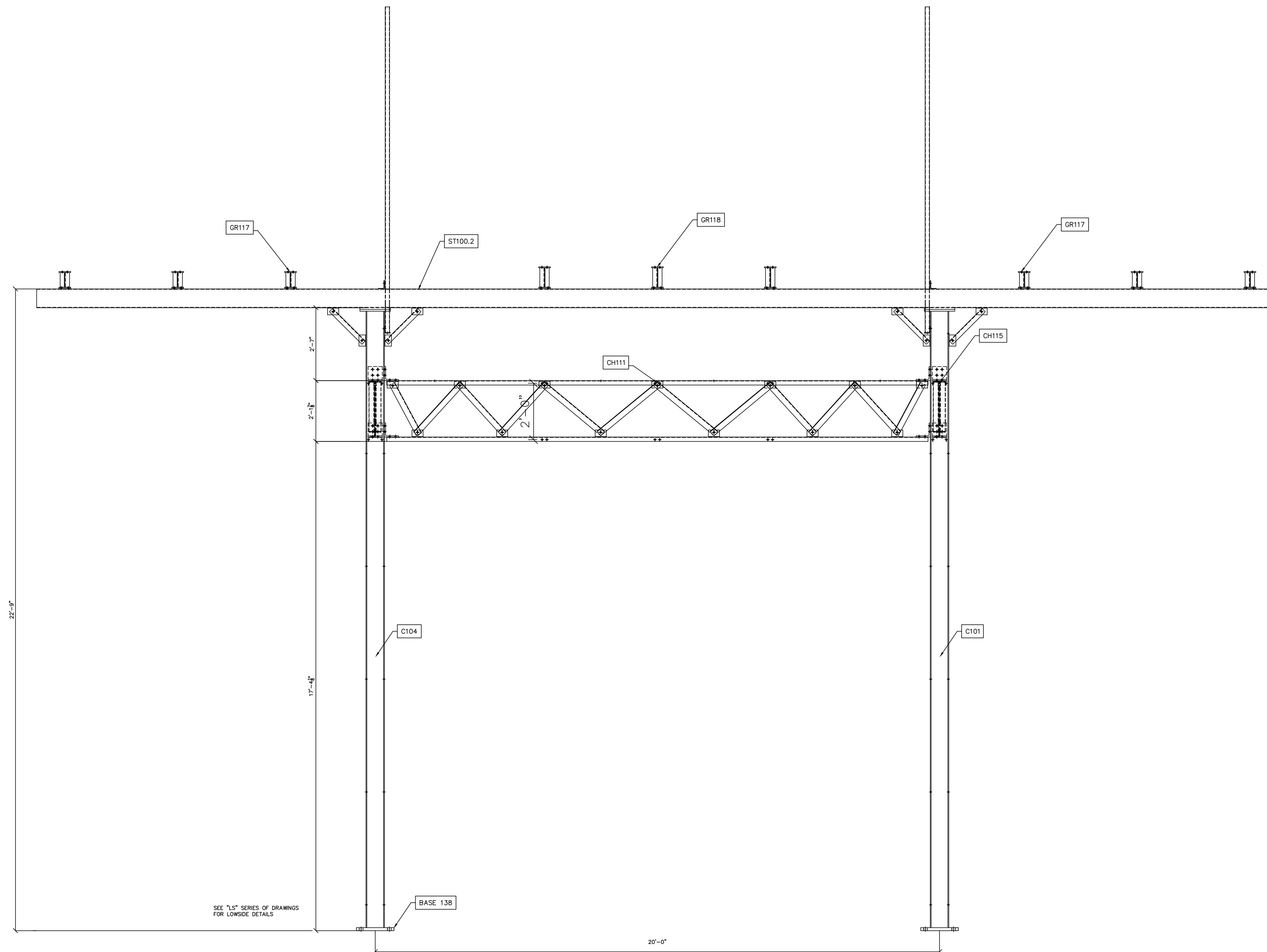

\* LABELS DENOTE GROUP DESIGNATIONS

LOWSIDE SECTION G-G  
SCALE: N.T.S.



Booth & Associates  
2200 Remwood Drive Suite 300, Raleigh, NC 27607  
N.C. F. 0221



PRELIMINARY -  
DO NOT USE FOR  
CONSTRUCTION

© 05/2023

NO.	ISSUED FOR BID	REVISIONS	ENG.	DATE
A			VK	05/10/2023

PROJECT NAME: CUMBERLAND ROAD  
69 TO 15 X 25 KV  
SUBSTATION  
DRAWING TITLE:  
OVERALL ERECTION DIAGRAM

DRAWN BY:	DJD
CHECKED BY:	VK
APPROVED BY:	VK
DATE:	05/10/2023
SCALE:	AS SHOWN
FILE NUMBER:	12510
SHEET:	

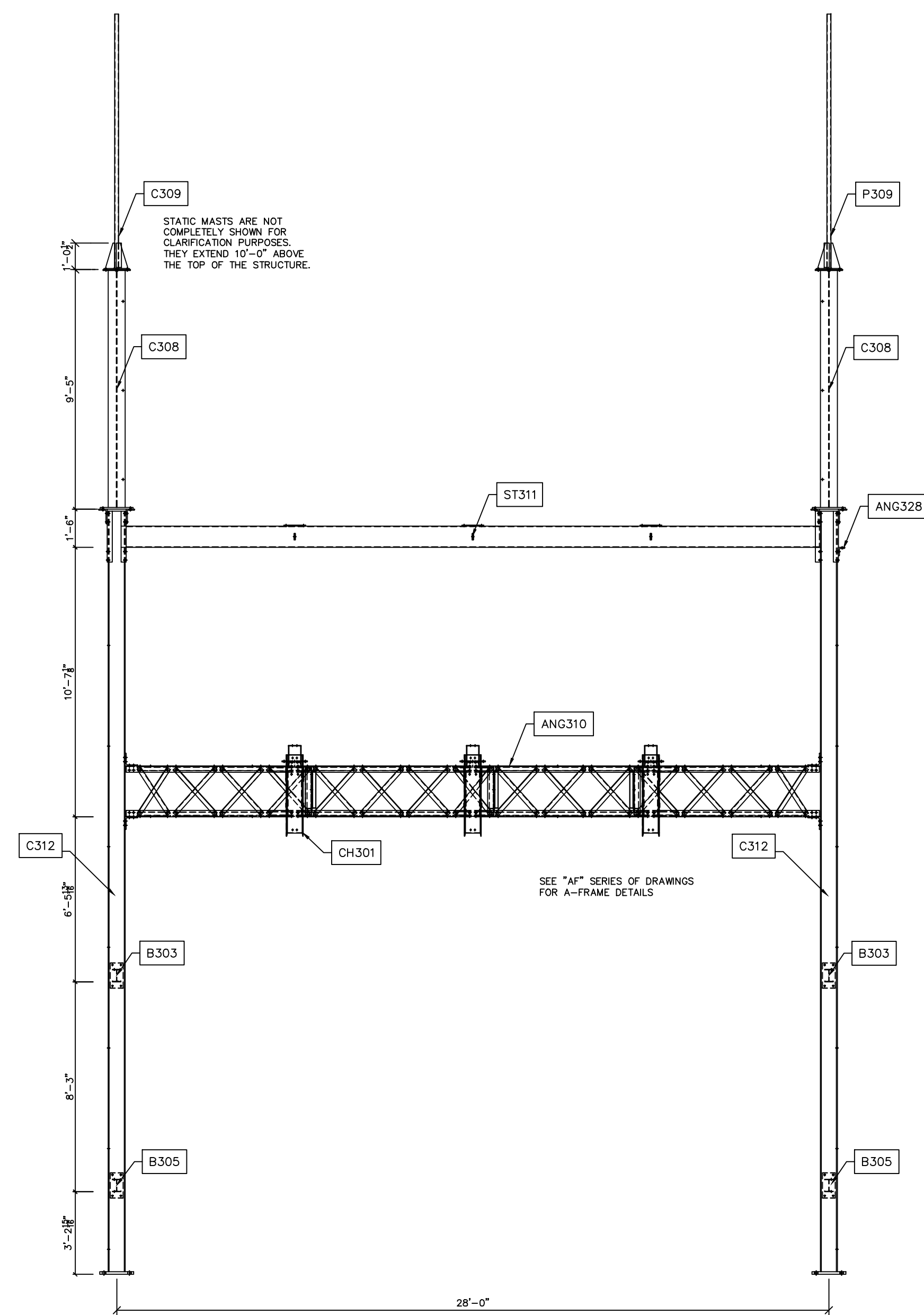

\* LABELS DENOTE GROUP DESIGNATIONS

A-FRAME SECTION H-H  
SCALE: N.T.S.



PRELIMINARY -  
DO NOT USE FOR  
CONSTRUCTION

© 05/2023

NO.	ISSUED FOR BID	REVISIONS	ENG.	DATE
A			VK	06/10/2023

PROJECT NAME: CUMBERLAND ROAD  
69 TO 15 X 25 KV  
SUBSTATION  
DRAWING TITLE:  
OVERALL ERECTION DIAGRAM

DRAWN BY:	DJD
CHECKED BY:	VK
APPROVED BY:	VK
DATE:	05/10/2023
SCALE:	AS SHOWN
FILE NUMBER:	12510
SHEET:	

PRELIMINARY -  
DO NOT USE FOR  
CONSTRUCTION

© 05/2023

NO.	ISSUED FOR BID	REVISIONS	ENG.	DATE
A	ISSUED FOR BID		VK	06/10/2023

PROJECT NAME: CUMBERLAND ROAD  
69 TO 15 X 25 KV  
SUBSTATION

DRAWING TITLE:  
**OVERALL ERECTION DIAGRAM**

DRAWN BY:	DJD
CHECKED BY:	VK
APPROVED BY:	VK
DATE:	05/10/2023
SCALE:	AS SHOWN
FILE NUMBER:	12510
SHEET:	

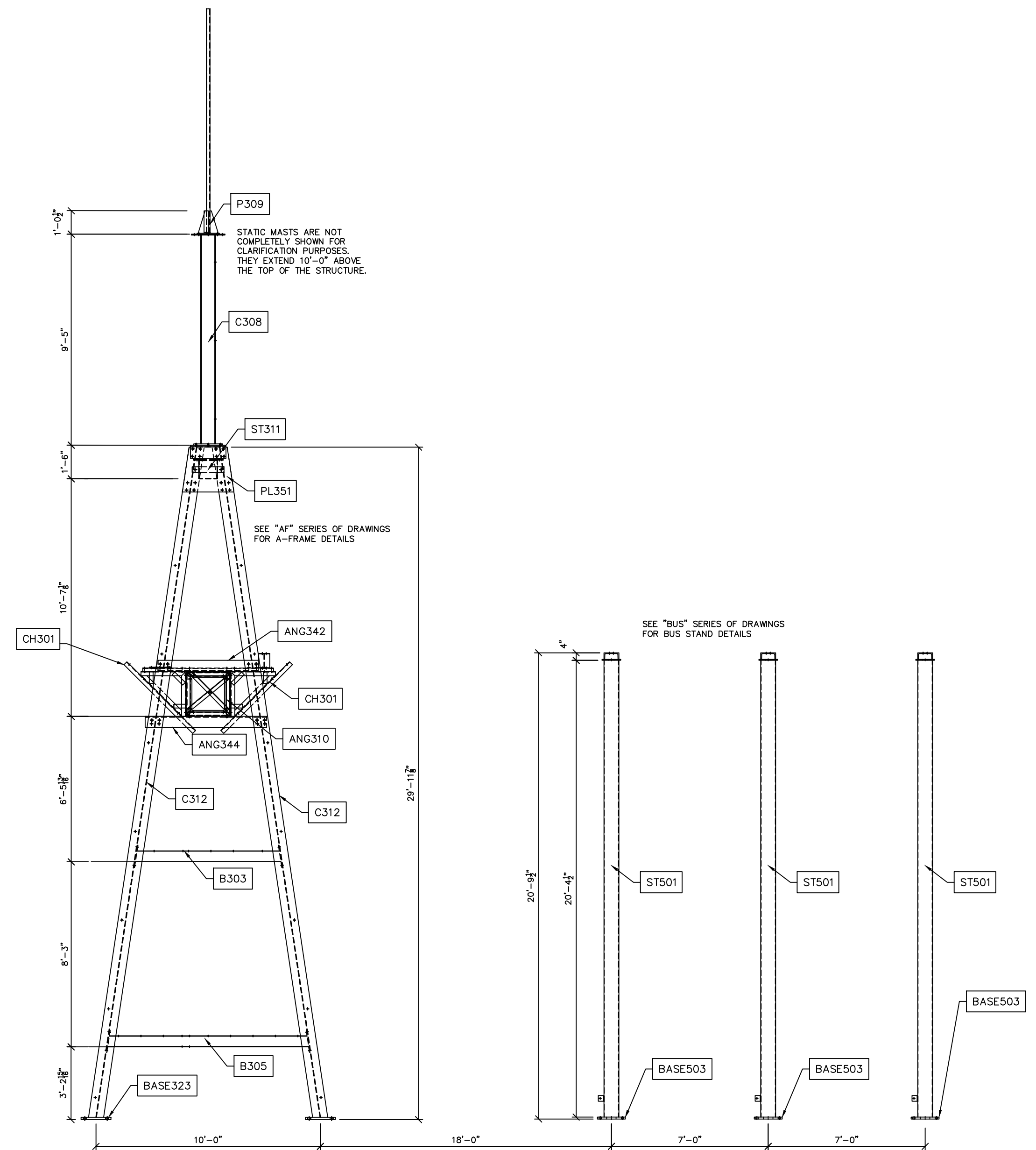

LOW BUS STAND/A-FRAME SECTION J-J  
SCALE: N.T.S.

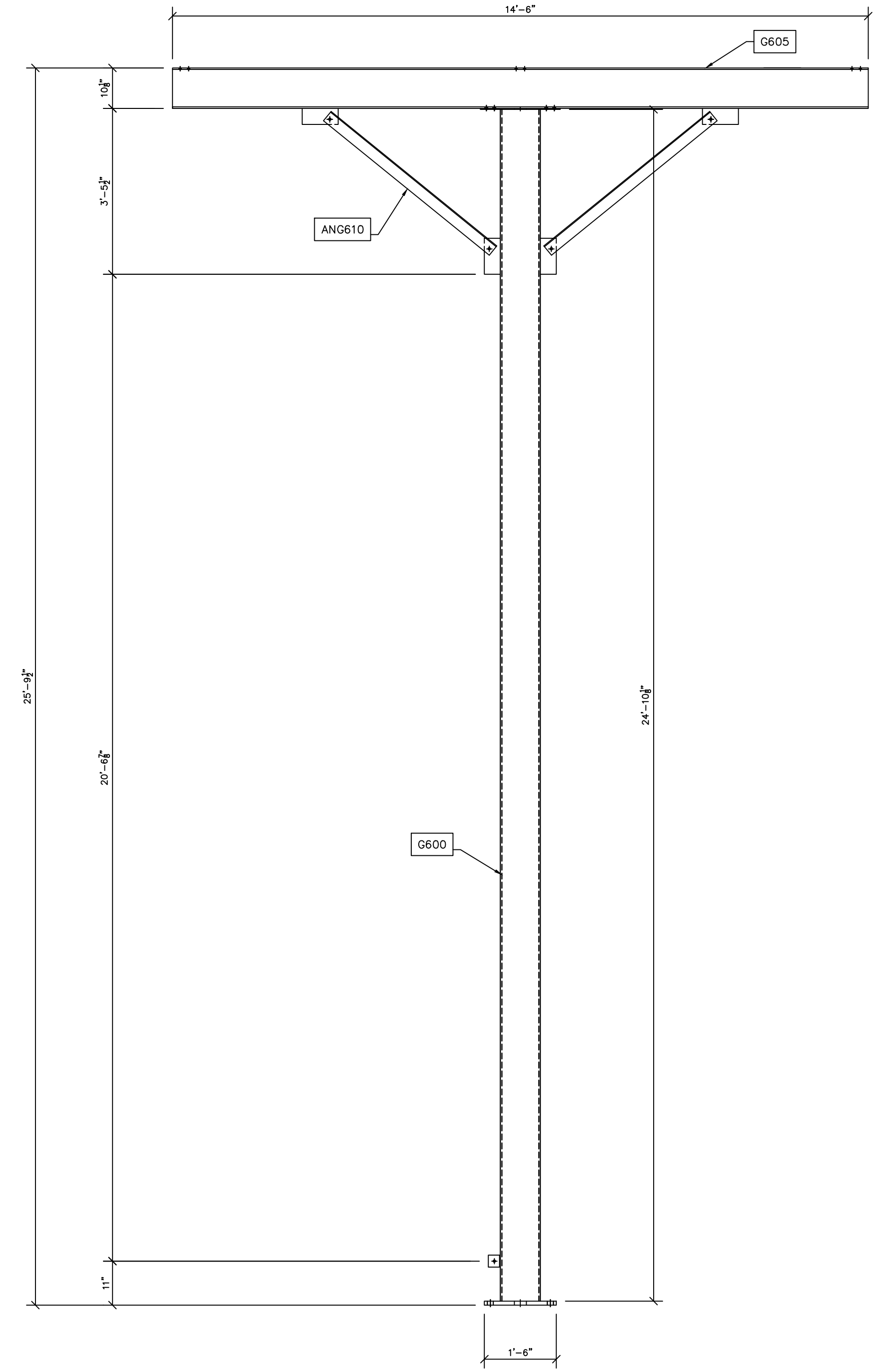

THREE PHASE BUS STAND SECTION K-K  
SCALE: N.T.S.

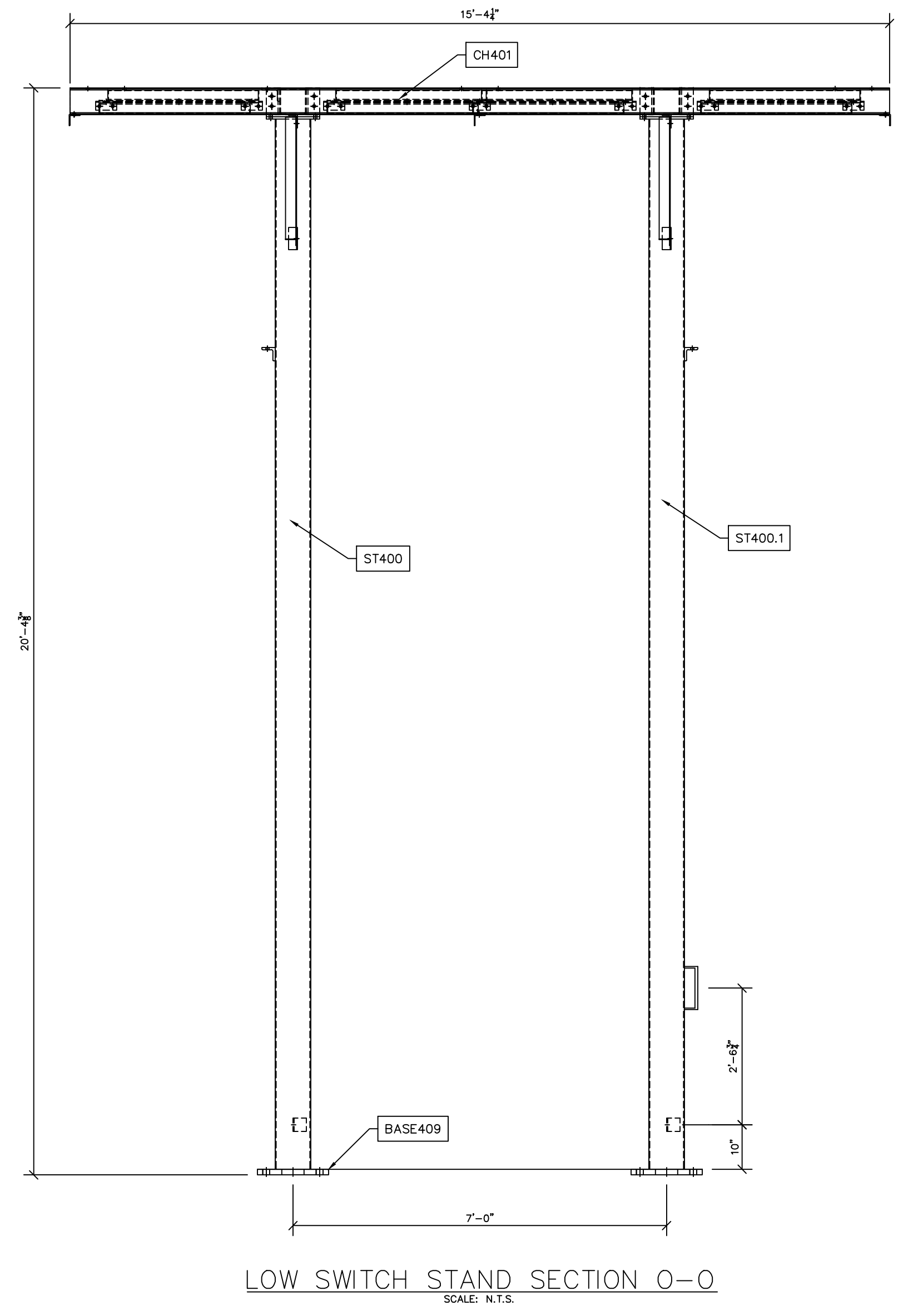
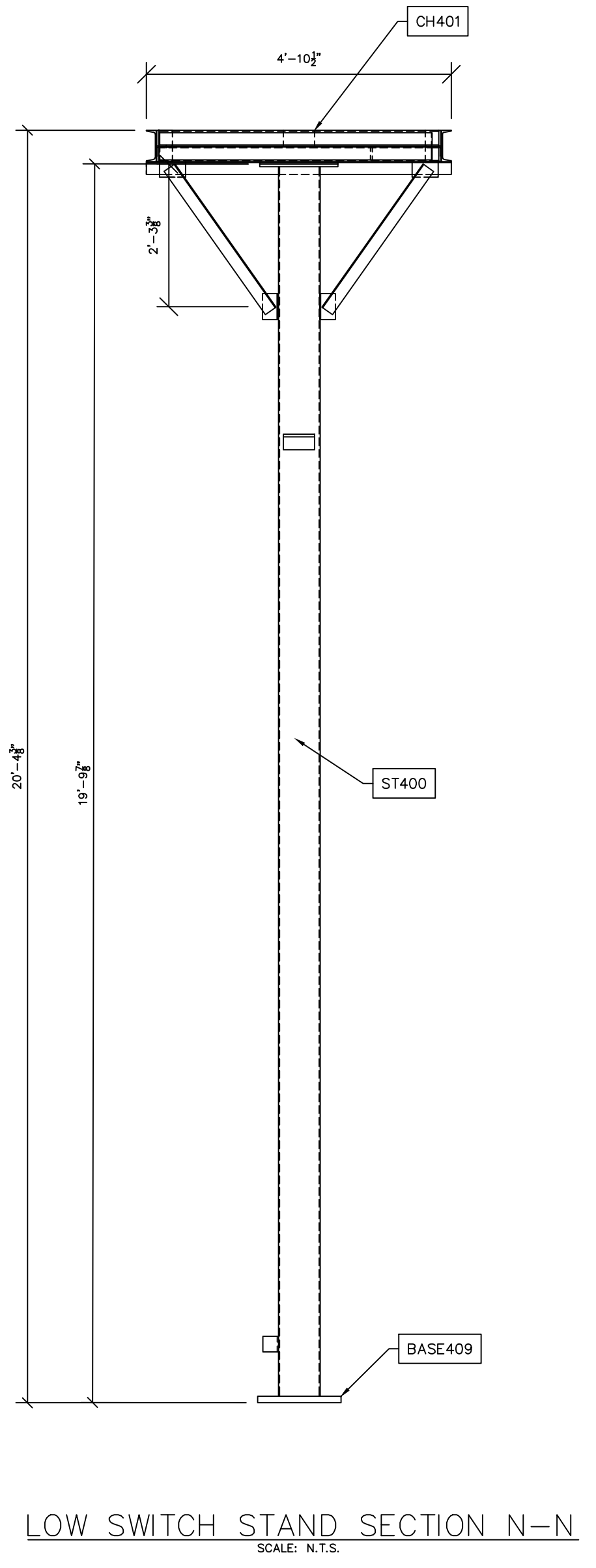
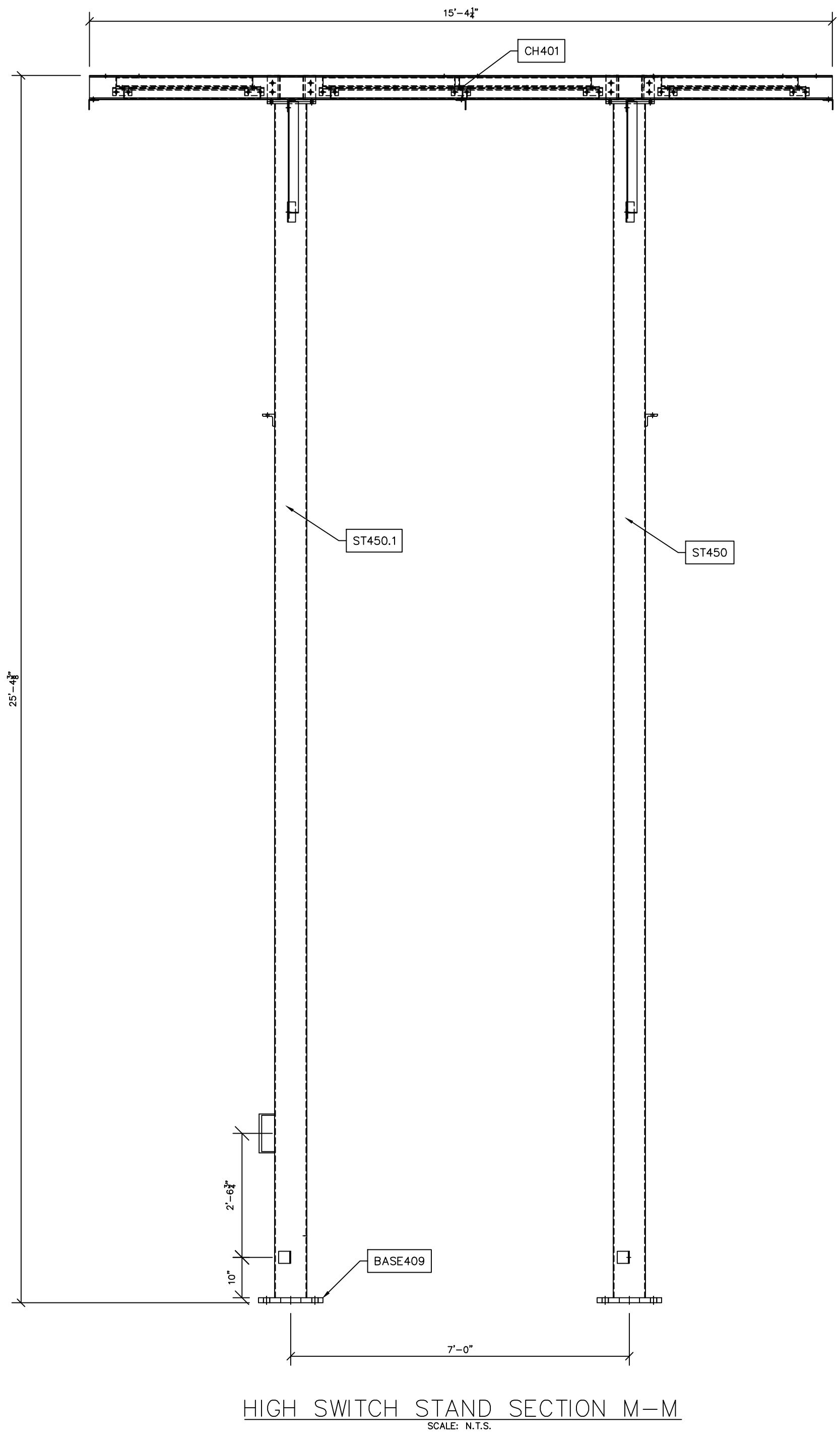
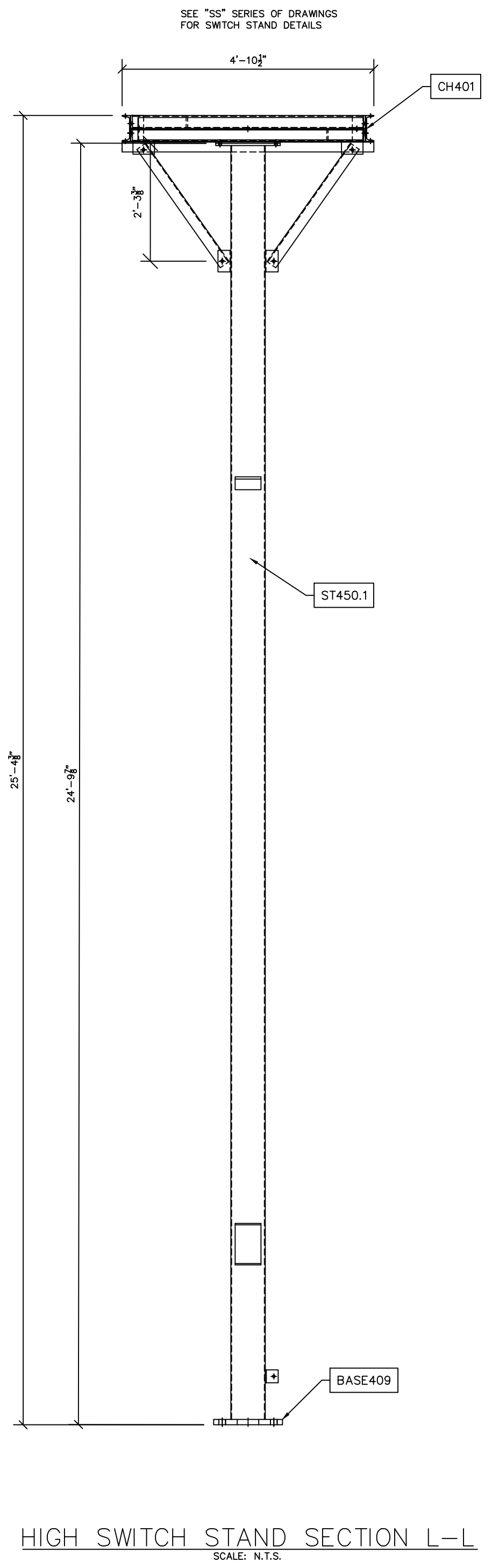

**PRELIMINARY -  
DO NOT USE FOR  
CONSTRUCTION**

© 05/2023

NO.	ISSUED FOR BID	REVISIONS	ENG.	DATE
A			VK	06/10/2023

PROJECT NAME: CUMBERLAND ROAD  
69 TO 15 X 25 KV  
SUBSTATION

DRAWING TITLE:  
**OVERALL ERECTION DIAGRAM**

DRAWN BY:	DJD
CHECKED BY:	VK
APPROVED BY:	VK
DATE:	05/10/2023
SCALE:	AS SHOWN
FILE NUMBER:	12510
SHEET:	

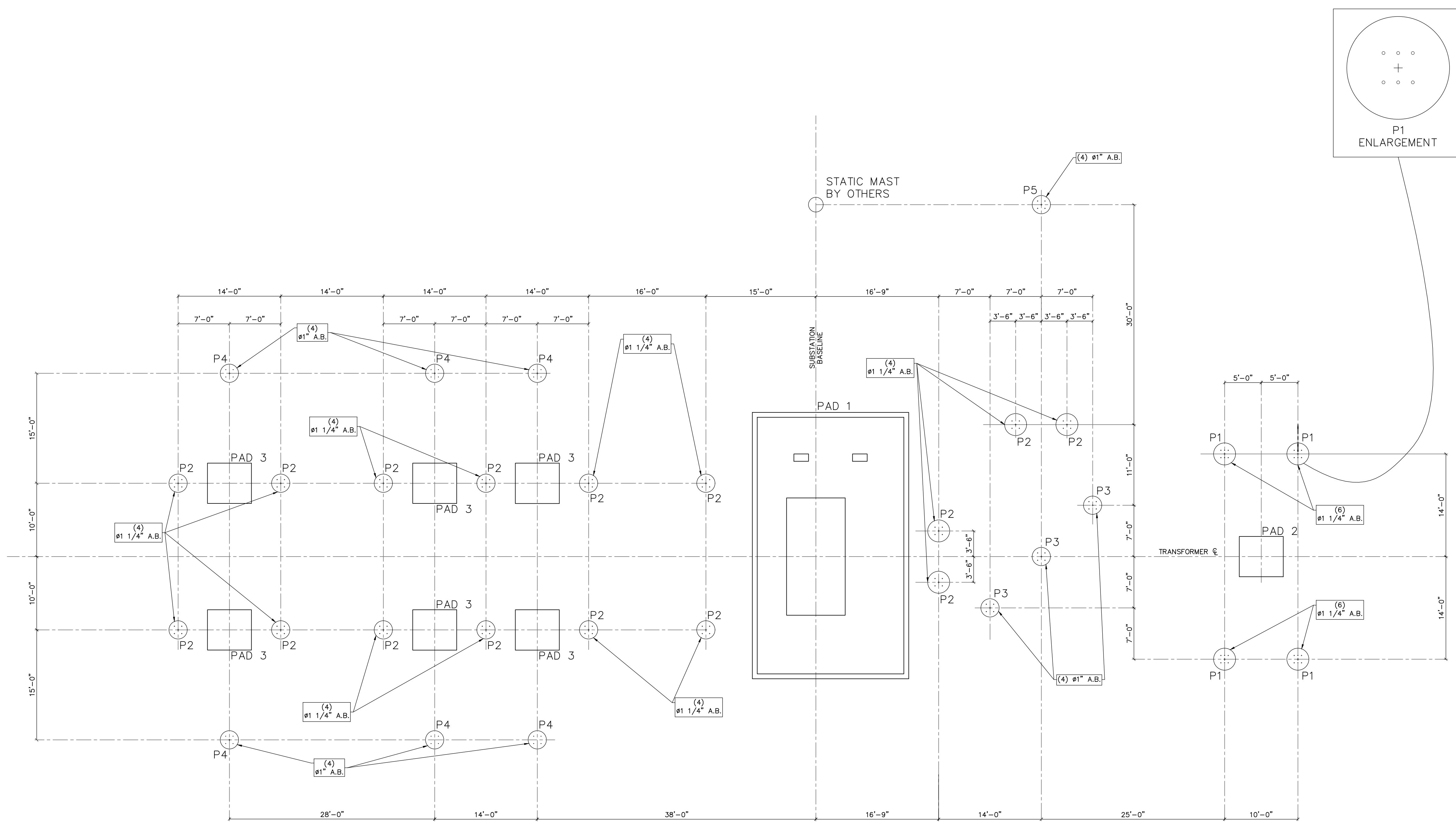

ANCHOR BOLT PLAN  
SCALE: 1/8"=1'-0"

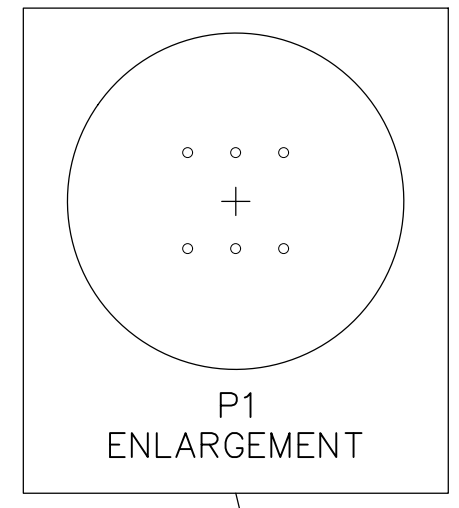
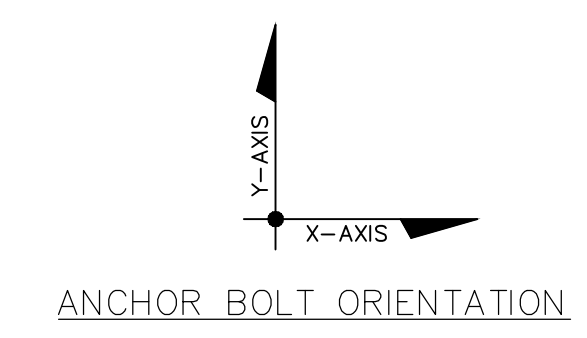

**Booth & Associates**  
2300 Rawwood Drive Suite 300, Raleigh, NC 27607  
N.C. F. 0221

**PRELIMINARY -  
DO NOT USE FOR  
CONSTRUCTION**

© 05/2023

NO.	ISSUED FOR BID	REVISIONS	ENG.	DATE
A			VK	05/10/2023

PROJECT NAME: CUMBERLAND ROAD  
69 TO 15 X 25 KV  
SUBSTATION

DRAWING TITLE:  
**ANCHOR BOLT PLAN**

DRAWN BY:	DJD
CHECKED BY:	VK
APPROVED BY:	VK
DATE:	05/10/2023
SCALE:	AS SHOWN
FILE NUMBER:	12510
SHEET:	

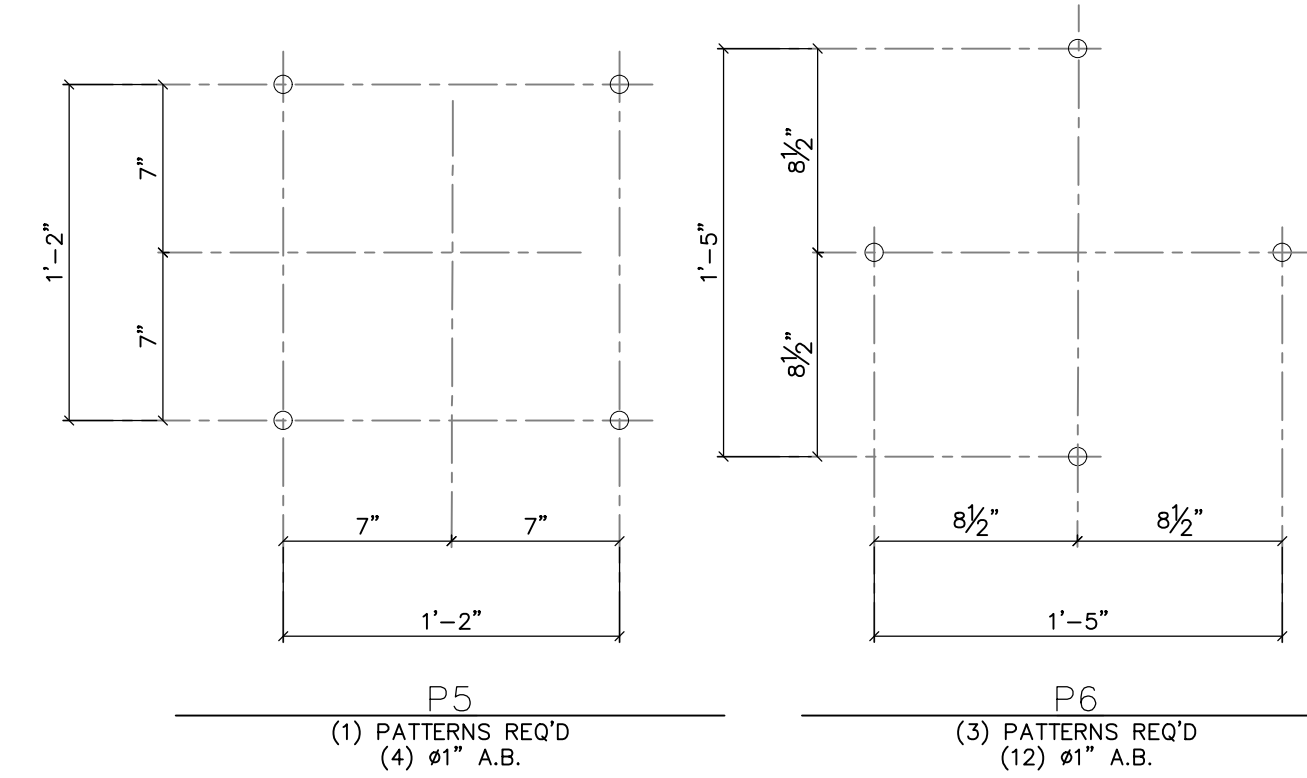
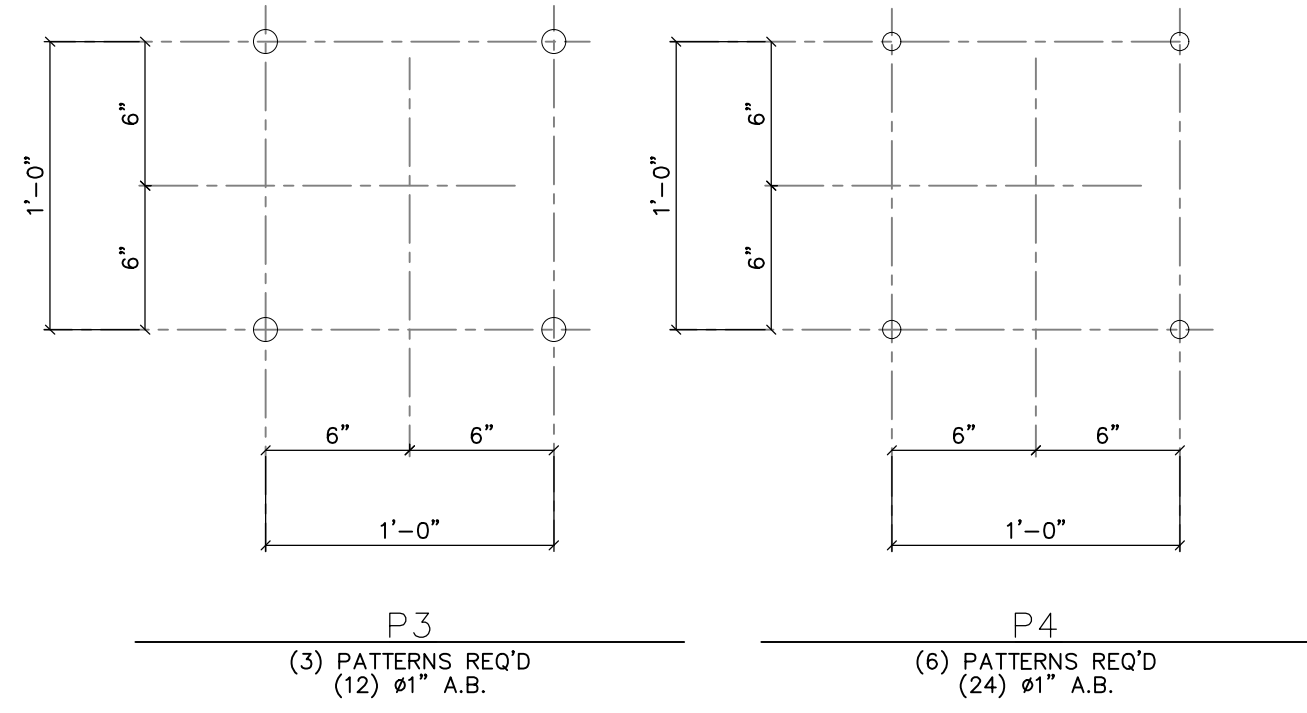
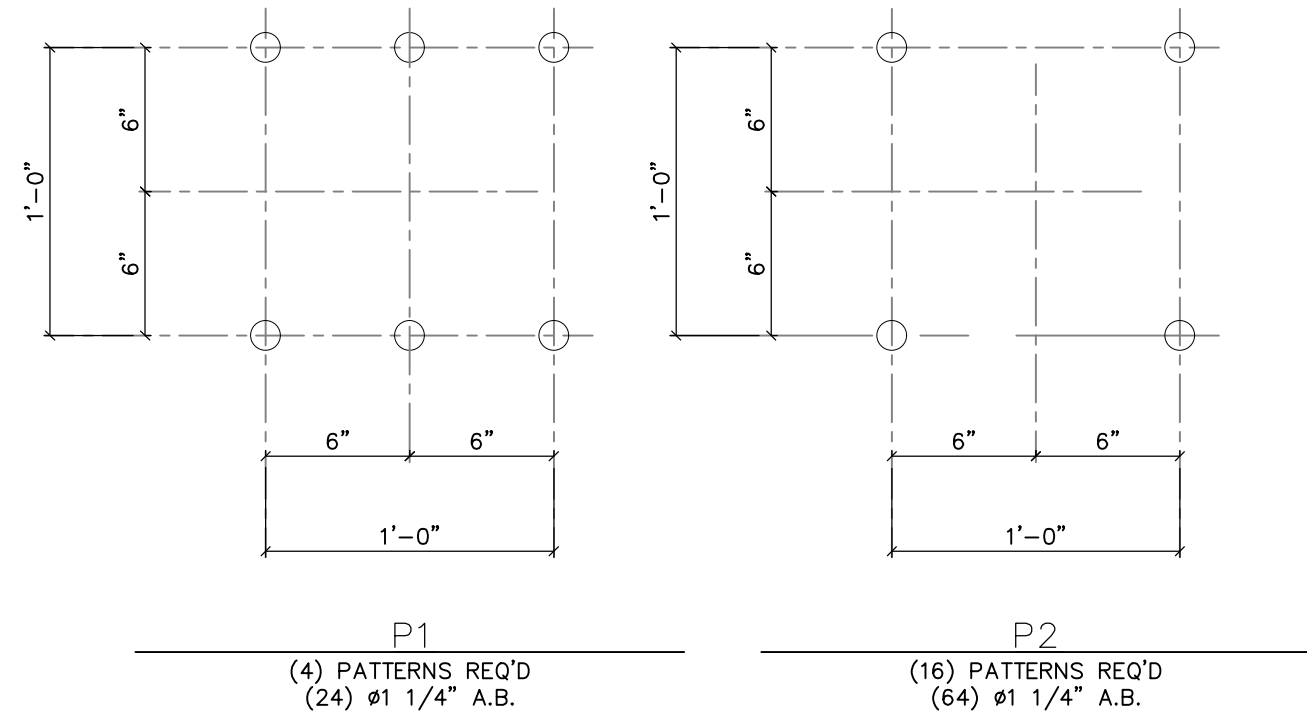
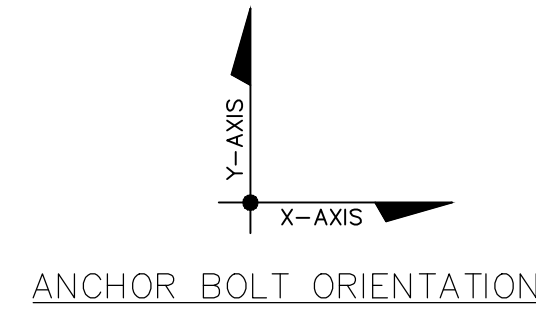

ANCHOR BOLT DETAILS  
SCALE: 1-1/2" = 1'-0"

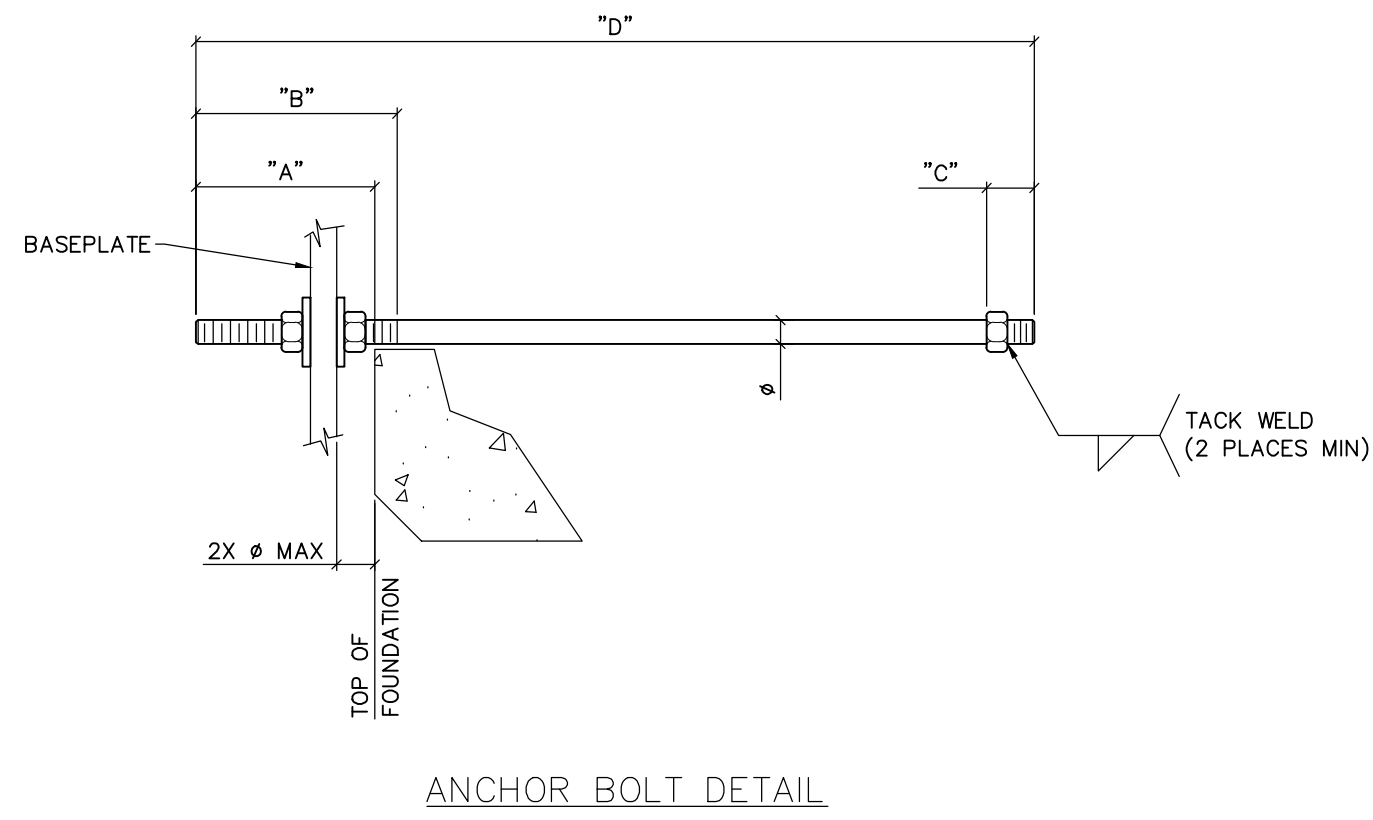

ANCHOR BOLT SUMMARY							
ANCHOR BOLTS PATTERN No.	ANCHOR BOLTS ITEM No.	QTY.	DIAMETER $\phi$	"A" PROJECTION LENGTH	"B" THREAD LENGTH/TOP	"C" THREAD LENGTH/BOTTOM	"D" BOLT LENGTH
P1, P2	AB-1	88	1 1/4"	6"	6"	2"	3'-6"
P3, P4, P5, P6	AB-2	52	1"	4 1/2"	5"	2"	2'-6"

NOTE: BOLTS SHALL BE HOT-DIP GALVANIZED PAST TO THREAD IN ACCORDANCE WITH ASTM A123.



PRELIMINARY - DO NOT USE FOR CONSTRUCTION

© 05/2023

NO.	ISSUED FOR BID	REVISIONS	ENG.	DATE
A			VK	05/10/2023

PROJECT NAME: CUMBERLAND ROAD TO 15 X 25 KV SUBSTATION  
DRAWING TITLE: ANCHOR BOLT DETAILS

DRAWN BY:	DJD
CHECKED BY:	VK
APPROVED BY:	VK
DATE:	05/10/2023
SCALE:	AS SHOWN
FILE NUMBER:	12510
SHEET:	

AB-2



- NOTES:
- 1) ASTM 325 ERECTION BOLTS
  - 2) ALL HOT DIP GALVANIZED AFTER FABRICATION (ASTM A123)
  - 3) ALL HOLES 11/16" DIA. FOR 5/8" DIA. BOLTS UNLESS NOTED
  - 4) PIECE MARK STAMPED INTO METAL WITH NOT LESS THAN 3/8" HIGH CHARACTERS BEFORE GALVANIZING
  - 5) ALL WELDING ELECTRODES SHALL BE E7021
  - 6) EDGE DISTANCE 1" UNLESS NOTED

BILL OF MATERIAL				
POS. NO.	QTY	DESC.	LENGTH	
<b>G100</b>	<b>2</b>	<b>FOR ONE GROUP G100</b>		
ANG139	1	L3-1/2x2-1/2x1/4	1'-2"	5.72
ANG140	1	L3-1/2x2-1/2x1/4	1'-2"	5.72
PL152	2	PL 3/4"x1'-1"	1'-1"	72.03
PL153	6	PL 1/4"x10 1/4"	1'-2"	61.16
PL155	3	PL 3/8"x5"	1'-0"	19.18
ST100	1	HSS8x3/16	44'-0"	862.90
WT135	4	WT4x15.5	4 3/4"	24.54
CH100.3	2	C8x11.5	8"	15.34

BLACK WEIGHT: 1066.59 LBS.  
 GALVANIZED WEIGHT: 42.66 LBS.  
 TOTAL WEIGHT: 1109.25 LBS.

SEE DRAWING No. LS-05 FOR CH 100.3, ANG139, ANG140, PL152, PL155, WT135 & END COVER DETAILS.

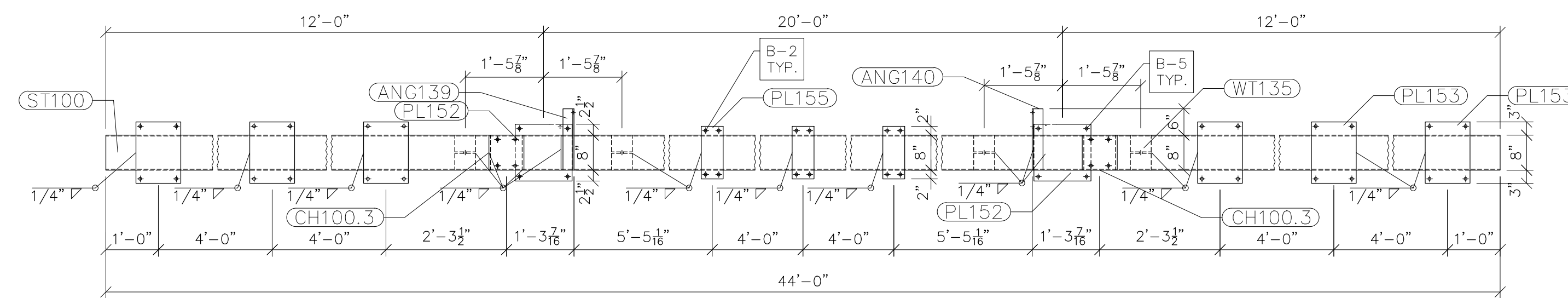

TOP VIEW

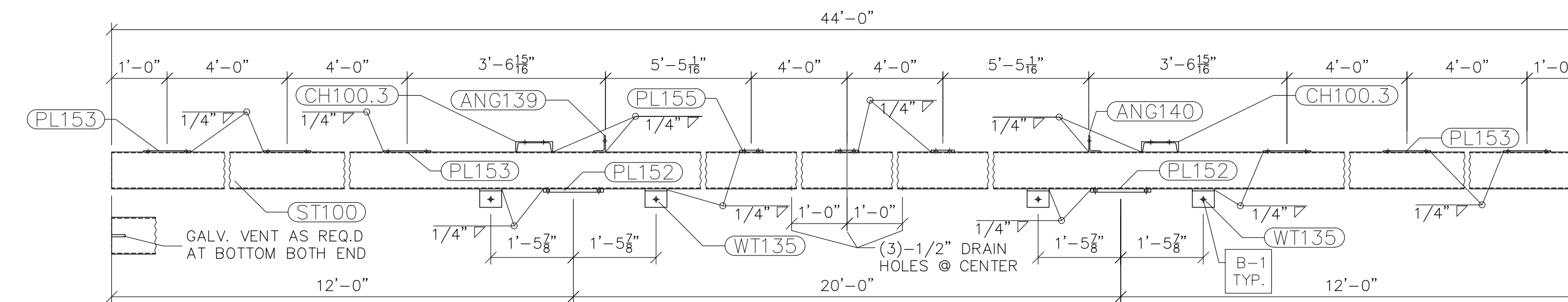

FRONT VIEW

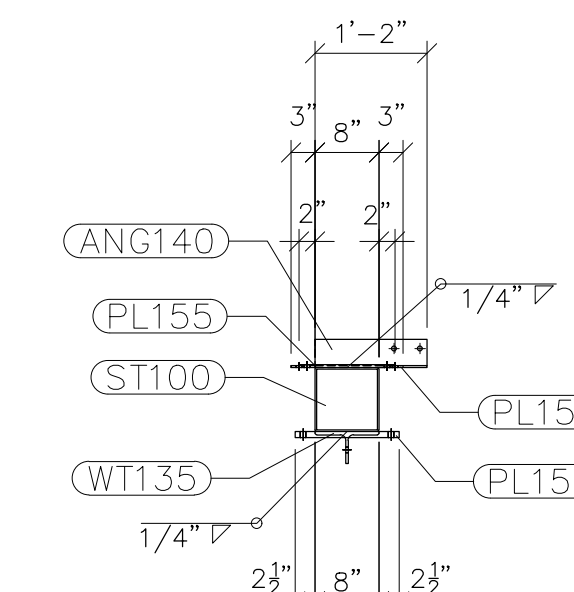

RIGHT VIEW

G100  
SCALE: N.T.S.



Booth & Associates  
2200 Renwood Drive Suite 300, Raleigh NC 27607  
N.C.F. 0021



PRELIMINARY -  
DO NOT USE FOR  
CONSTRUCTION

© 05/2023

NO.	ISSUED FOR BID	REVISIONS	ENG.	DATE
A			VK	06/10/2023

PROJECT NAME:	CUMBERLAND ROAD 69 TO 15 X 25 kV SUBSTATION
DRAWING TITLE:	LOW SIDE DETAILS (TRUSSES)
DRAWN BY:	DJD
CHECKED BY:	VK
APPROVED BY:	VK
DATE:	05/10/2023
SCALE:	AS SHOWN
FILE NUMBER:	12510
SHEET:	

- NOTES:
- 1) ASTM 325 ERECTION BOLTS
  - 2) ALL HOT DIP GALVANIZED AFTER FABRICATION (ASTM A123)
  - 3) ALL HOLES 11/16" DIA. FOR 5/8" DIA. BOLTS UNLESS NOTED
  - 4) PIECE MARK STAMPED INTO METAL WITH NOT LESS THAN 3/8" HIGH CHARACTERS BEFORE GALVANIZING
  - 5) ALL WELDING ELECTRODES SHALL BE E7021
  - 6) EDGE DISTANCE 1" UNLESS NOTED

BILL OF MATERIAL			
POS. NO.	QTY	DESC.	LENGTH
<b>G100.1</b>	<b>1</b>		
ANG139	1	L3-1/2x2-1/2x1/4	1'-2"
ANG140	1	L3-1/2x2-1/2x1/4	1'-2"
PL152	2	PL 3/4"x1'-1"	1'-1"
PL153	6	PL 1/4"x10 1/4"	1'-2"
PL155	3	PL 3/8"x5"	1'-0"
ST100.1	1	HSS8x8x3/16	44'-0"
WT135	4	WT4x15.5	4 3/4"
CH100.3	2	C8x11.5	8"
		BLACK WEIGHT:	1066.47 LBS.
		GALVANIZED WEIGHT:	42.66 LBS.
		TOTAL WEIGHT:	1109.13 LBS.

SEE DRAWING No. LS-05 FOR CH100.3, ANG139, ANG140, PL152, PL153, WT135 & END COVER DETAILS.

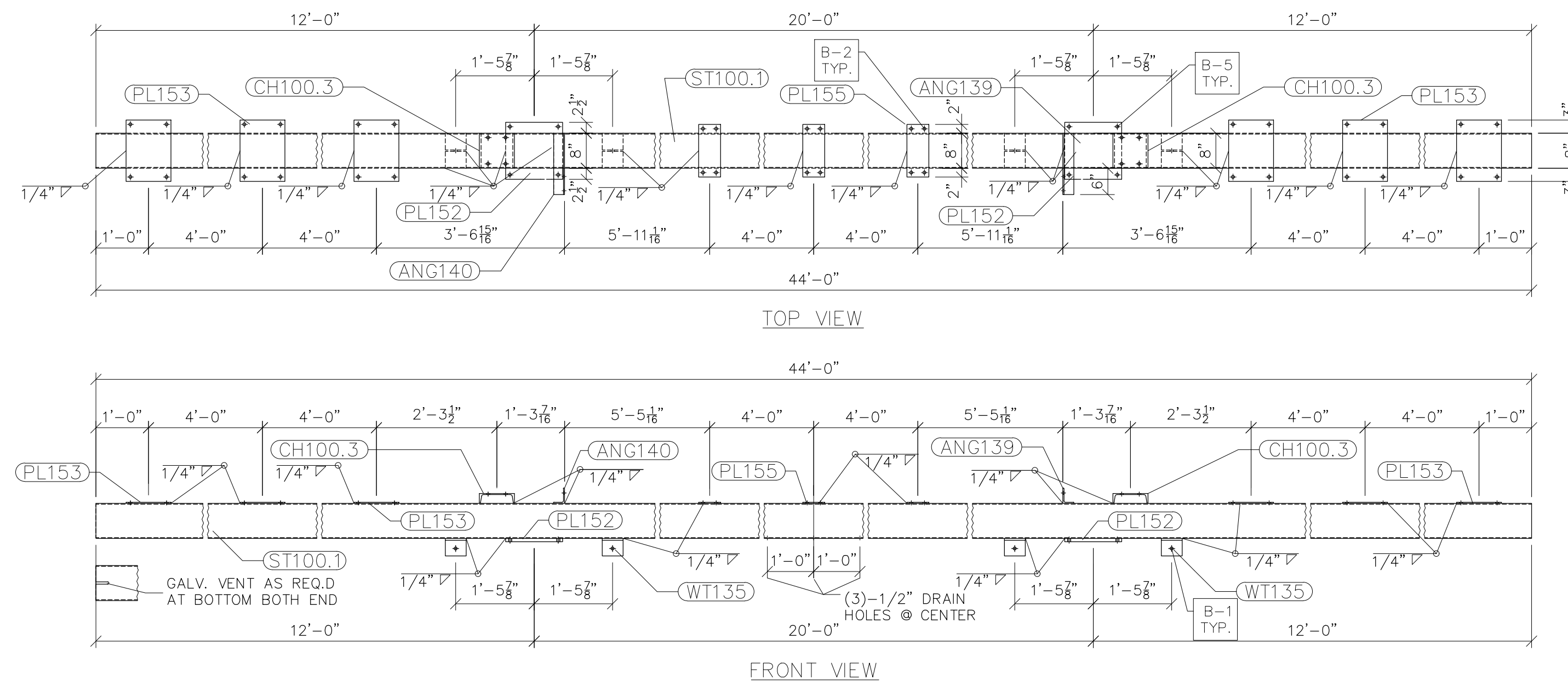

G100.1  
SCALE: N.T.S.



PRELIMINARY -  
DO NOT USE FOR  
CONSTRUCTION

© 05/2023

NO.	ISSUED FOR BID	REVISIONS	ENG. WK	DATE
A			VK	06/10/2023

PROJECT NAME: CUMBERLAND ROAD  
69 TO 15 X 25 kV  
SUBSTATION

DRAWING TITLE: LOW SIDE DETAILS (TRUSSES)

DRAWN BY:	DJD
CHECKED BY:	VK
APPROVED BY:	VK
DATE:	05/10/2023
SCALE:	AS SHOWN
FILE NUMBER:	12510
SHEET:	

NOTES:

- 1) ASTM 325 ERECTION BOLTS
- 2) ALL HOT DIP GALVANIZED AFTER FABRICATION (ASTM A123)
- 3) ALL HOLES 11/16" DIA. FOR 5/8" DIA. BOLTS UNLESS NOTED
- 4) PIECE MARK STAMPED INTO METAL WITH NOT LESS THAN 3/8" HIGH CHARACTERS BEFORE GALVANIZING
- 5) ALL WELDING ELECTRODES SHALL BE E7021
- 6) EDGE DISTANCE 1" UNLESS NOTED

BILL OF MATERIAL			
POS. NO.	QTY	DESC.	LENGTH
G100.2	2		
ANG139	1	L3-1/2x2-1/2x1/4	1'-2"
ANG140	1	L3-1/2x2-1/2x1/4	1'-2"
PL152	2	PL 3/4"x1'-1"	72.03
PL155	9	PL 3/8"x5"	1'-0"
ST100.2	1	HSS8x8x3/16	44'-0"
WT135	4	WT4x15.5	4 3/4"
		BLACK WEIGHT:	1028.45 LBS.
		GALVANIZED WEIGHT:	41.14 LBS.
		TOTAL WEIGHT:	1069.59 LBS.

SEE DRAWING No. LS-05 FOR ANG139, ANG140, PL152, PL155, WT135 & END COVER DETAILS.

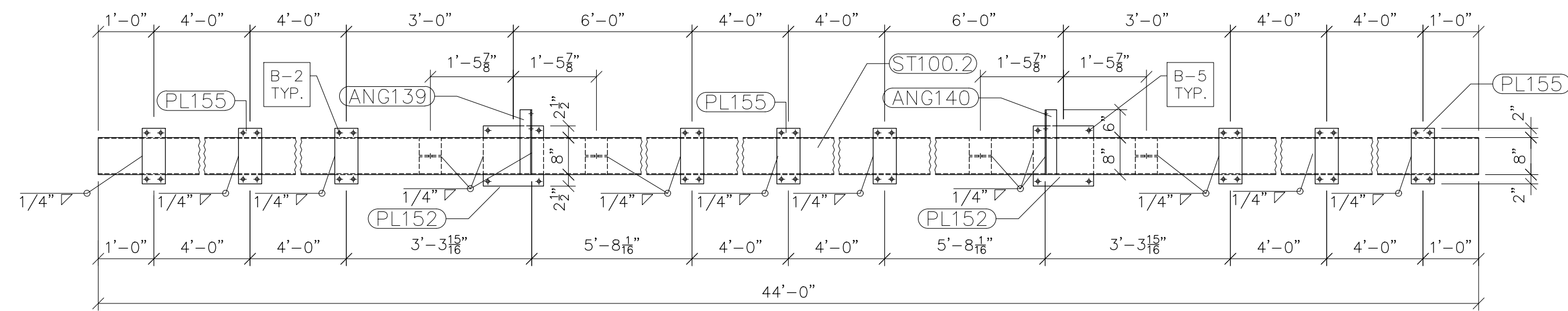

TOP VIEW

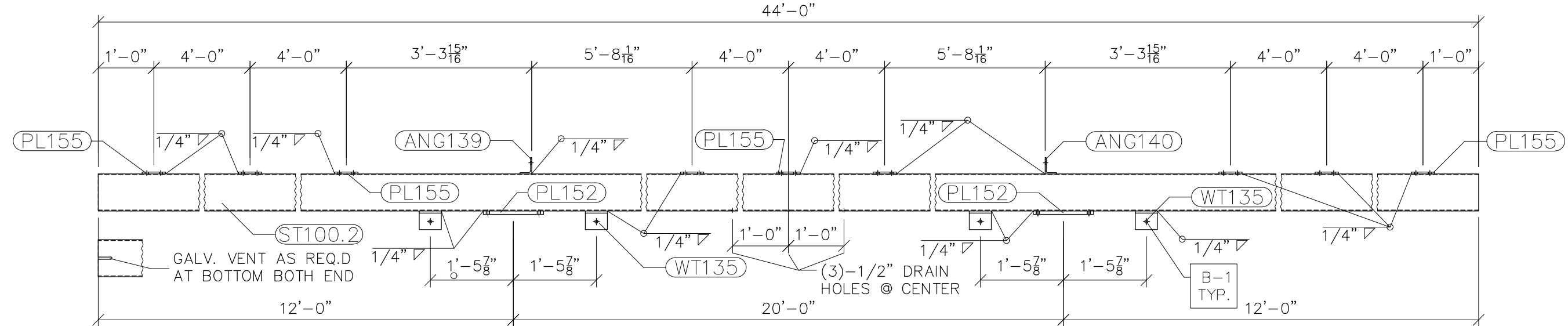

FRONT VIEW

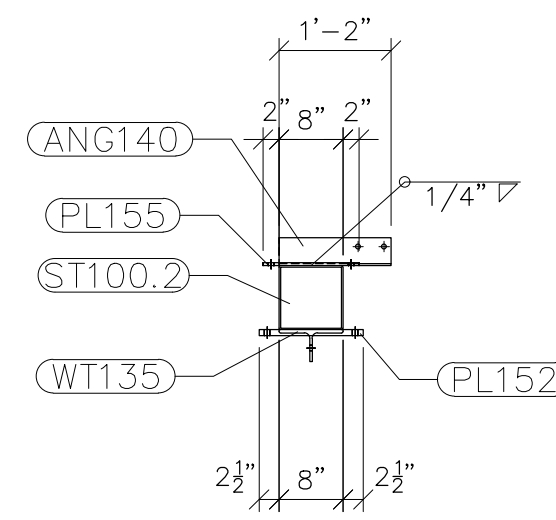

RIGHT VIEW

G100.2  
SCALE: N.T.S.



PRELIMINARY -  
DO NOT USE FOR  
CONSTRUCTION

© 05/2023

NO.	ISSUED FOR BID	REVISIONS	ENG.	DATE
A			VK	06/10/2023

PROJECT NAME:	CUMBERLAND ROAD 69 TO 15 X 25 kV SUBSTATION
DRAWING TITLE:	LOW SIDE DETAILS (TRUSSES)
DRAWN BY:	DJD
CHECKED BY:	VK
APPROVED BY:	VK
DATE:	05/10/2023
SCALE:	AS SHOWN
FILE NUMBER:	12510
SHEET:	

LS-03

- NOTES:  
 1) ASTM 325 ERECTION BOLTS  
 2) ALL HOT DIP GALVANIZED AFTER FABRICATION (ASTM A123)  
 3) ALL HOLES 11/16" DIA. FOR 5/8" DIA. BOLTS UNLESS NOTED  
 4) PIECE MARK STAMPED INTO METAL WITH NOT LESS THAN 3/8" HIGH CHARACTERS BEFORE GALVANIZING  
 5) ALL WELDING ELECTRODES SHALL BE E7021  
 6) EDGE DISTANCE 1" UNLESS NOTED

BILL OF MATERIAL				
POS. NO.	QTY	DESC.	LENGTH	
<b>G100.3</b>				
ANG139.1	1	L3-1/2x2-1/2x1/4	1'-2"	5.72
ANG140	1	L3-1/2x2-1/2x1/4	1'-2"	5.72
PL152	2	PL 3/4"x1'-1"	1'-2"	72.03
PL153	3	PL 1/4"x10 1/4"	1'-2"	30.58
ST100.3	1	HSS8x8x3/16	21'-1"	413.47
WT135	2	WT4x15.5	4 3/4"	12.27
CH100.3	1	C8x11.5	8"	7.67
			BLACK WEIGHT:	547.46 LBS.
			GALVANIZED WEIGHT:	21.90 LBS.
			TOTAL WEIGHT:	569.36 LBS.

SEE DRAWING No. LS-05 FOR ANG139.1, ANG140, PL152, PL153, & WT135 DETAILS.

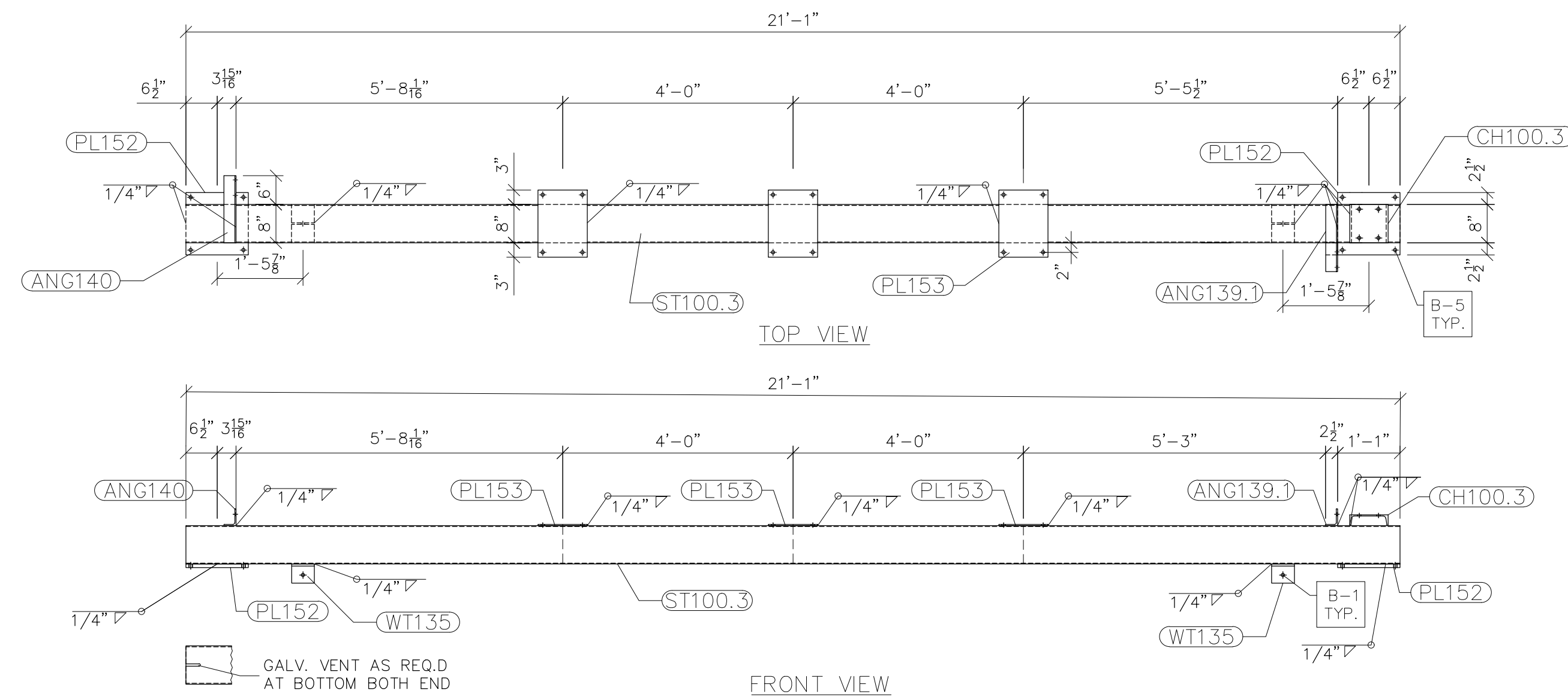

G100.3  
 SCALE: 1/2"=1'-0"



PRELIMINARY -  
 DO NOT USE FOR  
 CONSTRUCTION

© 05/2023

NO.	ISSUED FOR BID	REVISIONS	ENG.	DATE
A			VK	06/10/2023

PROJECT NAME:  
 CUMBERLAND ROAD  
 69 TO 15 X 25 kV  
 SUBSTATION

DRAWING TITLE:  
 LOW SIDE DETAILS (TRUSSES)

DRAWN BY:	DJD
CHECKED BY:	VK
APPROVED BY:	VK
DATE:	05/10/2023
SCALE:	AS SHOWN
FILE NUMBER:	12510
SHEET:	

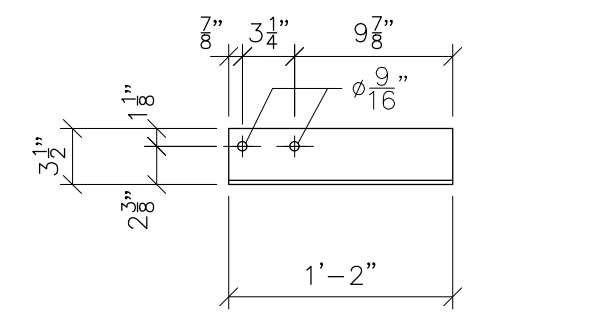

ANG139 FRONT VIEW  
SCALE: 1"=1'-0"

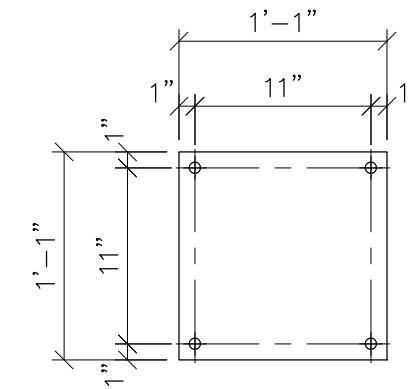

PL152  
SCALE: 1"=1'-0"

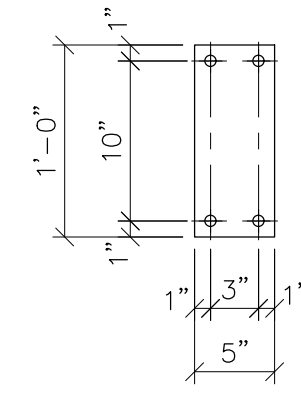

PL155  
SCALE: 1"=1'-0"

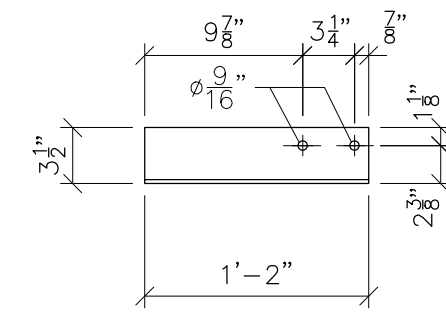

ANG140 FRONT VIEW  
SCALE: 1"=1'-0"

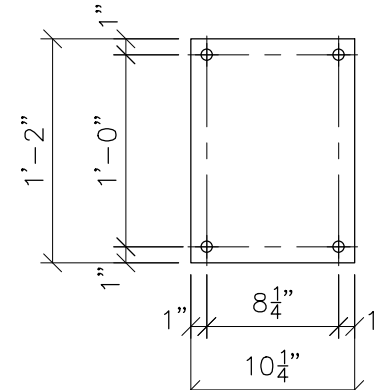

PL153  
SCALE: 1"=1'-0"

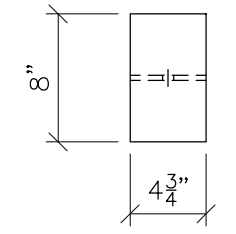

TOP VIEW

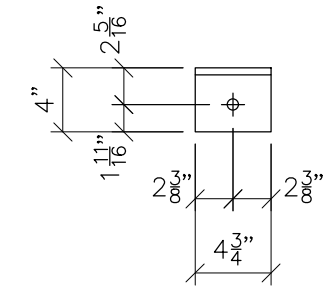

FRONT VIEW

WT135  
SCALE: 1"=1'-0"

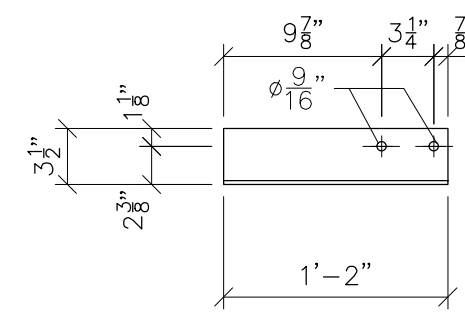

ANG139.1 FRONT VIEW  
SCALE: 1"=1'-0"

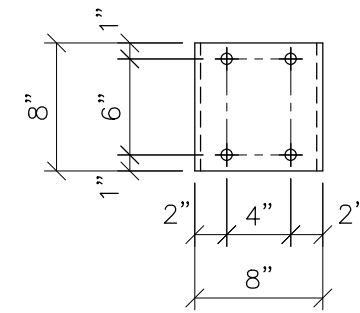

CH100.3  
SCALE: 1"=1'-0"

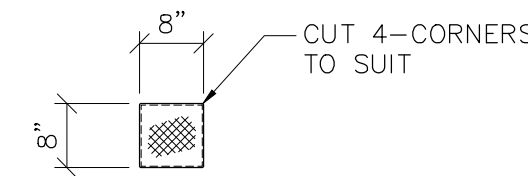

FOR ST 100, 100.1,  
100.2 & 100.3 BOTH END  
EXPANDED METAL STD. STYLE  
1/2 316 GAUGE, APPROX.  
WGT.=0.86LBS/SQ. FT.  
(1=0.38 LBS.)

TYP. END COVER  
SCALE: 1/2"=1'-0"

- NOTES:  
1) ASTM 325 ERECTION BOLTS  
2) ALL HOT DIP GALVANIZED AFTER FABRICATION (ASTM A123)  
3) ALL HOLES 11/16" DIA. FOR 5/8" DIA. BOLTS UNLESS NOTED  
4) PIECE MARK STAMPED INTO METAL WITH NOT LESS THAN 3/8" HIGH CHARACTERS BEFORE GALVANIZING  
5) ALL WELDING ELECTRODES SHALL BE E7021  
6) EDGE DISTANCE 1" UNLESS NOTED

BILL OF MATERIAL			
POS. NO.	QTY	DESC.	LENGTHxWIDTH WEIGHT
END COVER	10	MESH 1/2 #16 GAUGE	8"x8" 3.80
BLACK WEIGHT:			3.80 LBS.
GALVANIZED WEIGHT:			0.15 LBS.
TOTAL WEIGHT:			3.95 LBS.



PRELIMINARY -  
DO NOT USE FOR  
CONSTRUCTION

© 05/2023

NO.	REVISIONS	ENG.	DATE
A	ISSUED FOR BID	VK	06/10/2023

PROJECT NAME: CUMBERLAND ROAD  
69 TO 15 X 25 kV  
SUBSTATION  
DRAWING TITLE:  
LOW SIDE DETAILS (TRUSSES)

DRAWN BY:	DJD
CHECKED BY:	VK
APPROVED BY:	VK
DATE:	05/10/2023
SCALE:	AS SHOWN
FILE NUMBER:	12510
SHEET:	

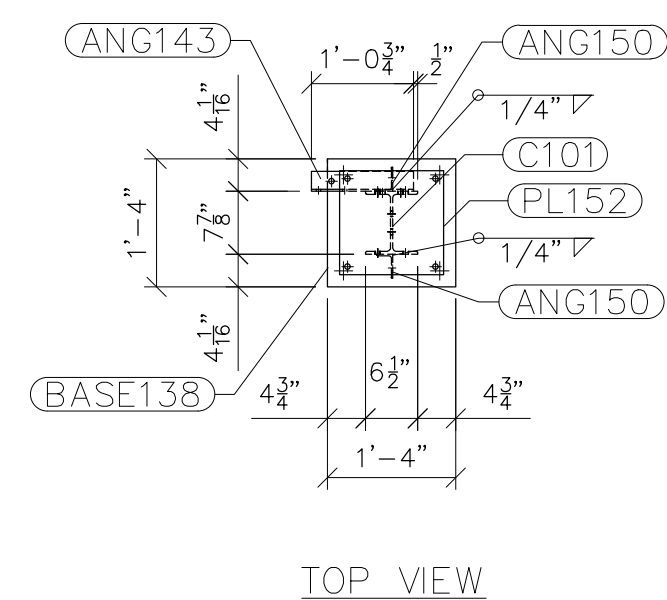
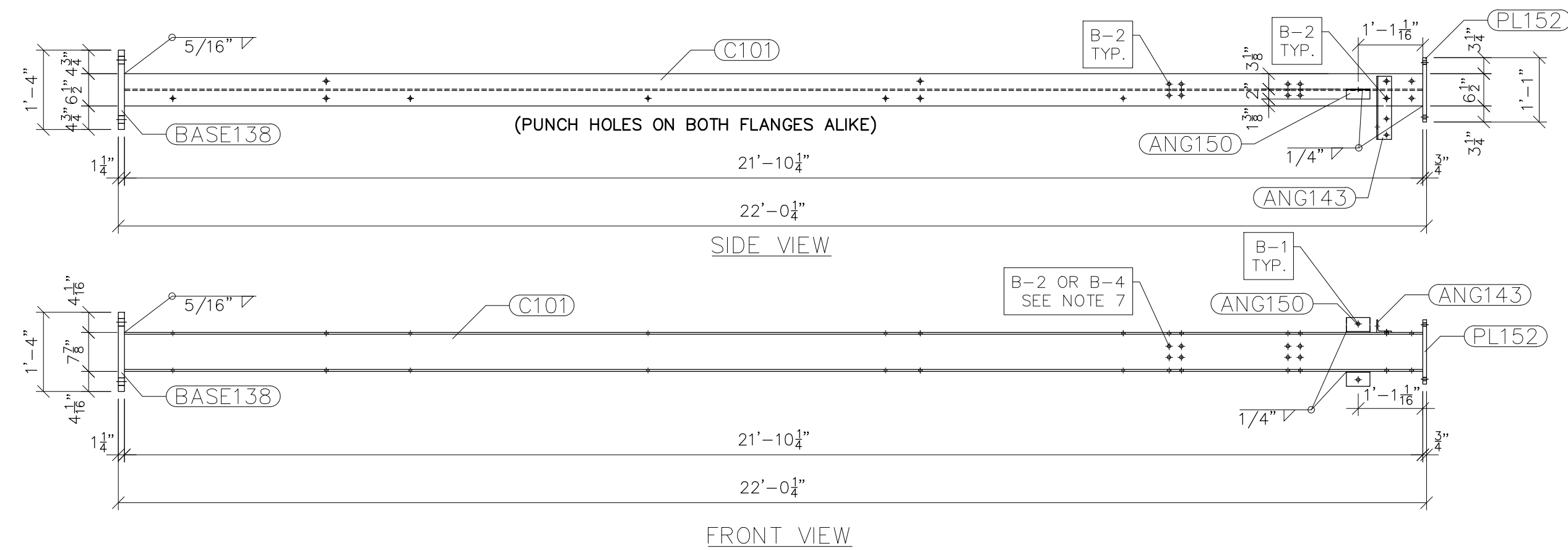

G101  
SCALE: 1/2"=1'-0"

- NOTES:
- 1) ASTM 325 ERECTION BOLTS
  - 2) ALL HOT DIP GALVANIZED AFTER FABRICATION (ASTM A123)
  - 3) ALL HOLES 11/16" DIA. FOR 5/8" DIA. BOLTS UNLESS NOTED
  - 4) PIECE MARK STAMPED INTO METAL WITH NOT LESS THAN 3/8" HIGH CHARACTERS BEFORE GALVANIZING
  - 5) ALL WELDING ELECTRODES SHALL BE E7021
  - 6) EDGE DISTANCE 1" UNLESS NOTED
  - 7) ERECTION BOLT LENGTH VARIES WHERE NOTED. B2 TO BE USED IN CASES WHERE A SINGLE TRUSS IS CONNECTED TO COLUMN. B-4 TO BE USED IN CASES WHERE TWO TRUSSES ARE CONNECTED TO COLUMN.

BILL OF MATERIAL				
POS. NO.	QTY	DESC.	LENGTH	WEIGHT
<b>G101</b>	<b>2</b>	<b>FOR ONE GROUP G101</b>		
ANG143	1	L3x2-1/2x1/4	1'-0 3/4"	4.78
ANG150	2	L3x2x3/16	4 3/4"	2.43
BASE138	1	PL 1 1/4"x1'-4"	1'-4"	90.93
C101	1	W8x24	21'-10 1/4"	524.50
PL152	1	PL 3/4"x1'-1"	1'-1"	36.01
			BLACK WEIGHT:	658.65 LBS.
			GALVANIZED WEIGHT:	26.35 LBS.
			TOTAL WEIGHT:	685.00 LBS.

SEE DRAWING No. LS-11 FOR ANG143, ANG150, BASE138 & PL152 DETAILS AND NOTES.

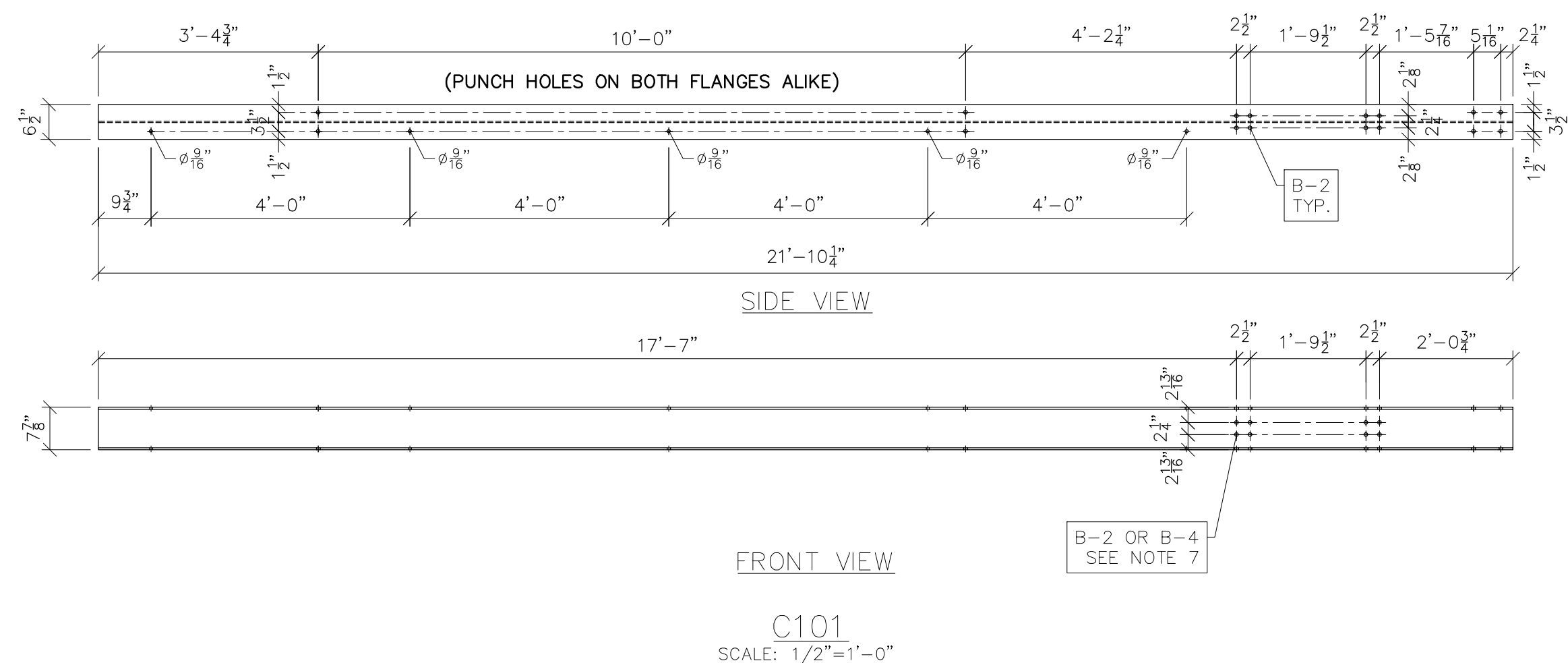

C101  
SCALE: 1/2"=1'-0"



PRELIMINARY -  
DO NOT USE FOR  
CONSTRUCTION

© 05/2023

NO.	ISSUED FOR BID	REVISIONS	ENG.	DATE
A			VK	06/10/2023

PROJECT NAME:	CUMBERLAND ROAD 69 TO 15 X 25 kV SUBSTATION
DRAWING TITLE:	LOW SIDE DETAILS (TRUSSES)
DRAWN BY:	DJD
CHECKED BY:	VK
APPROVED BY:	VK
DATE:	05/10/2023
SCALE:	AS SHOWN
FILE NUMBER:	12510
SHEET:	

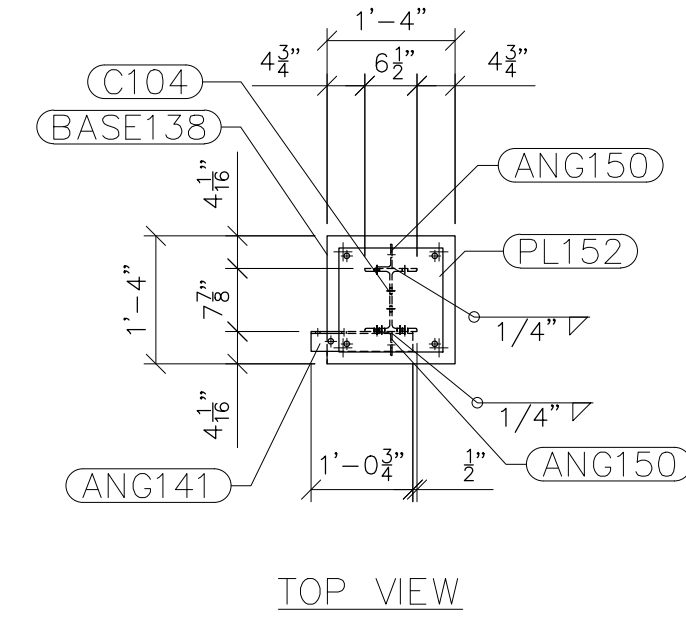
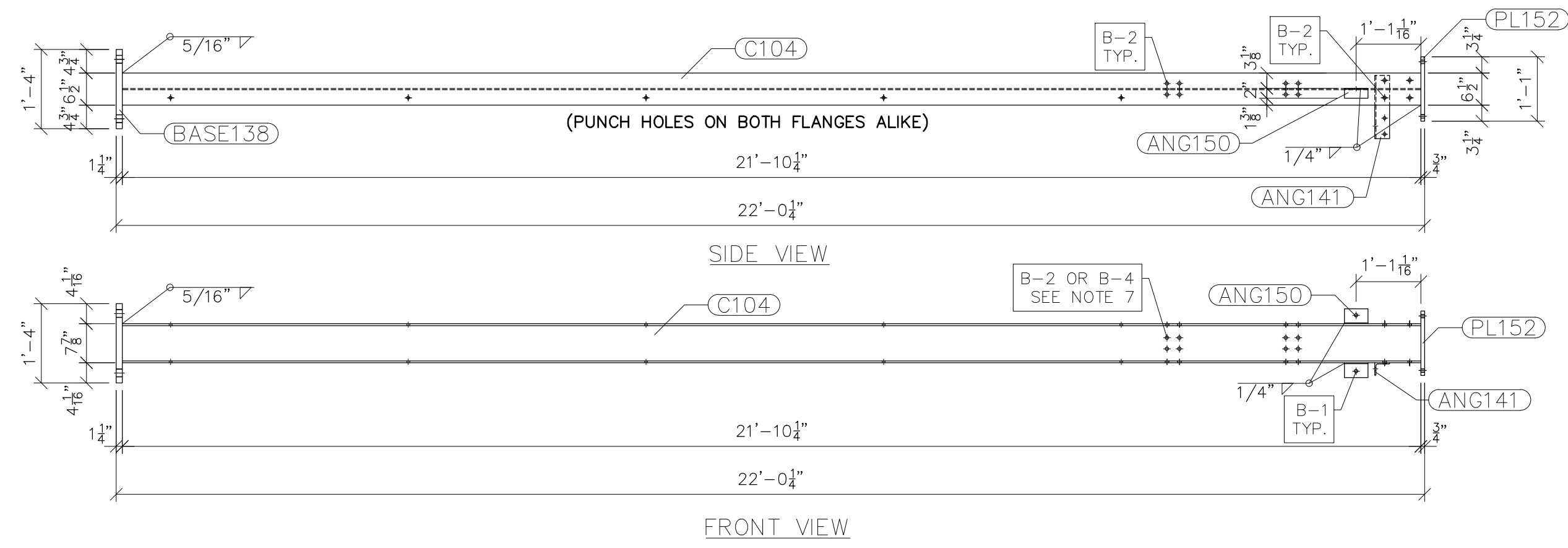

TOP VIEW

- NOTES:
- 1) ASTM 325 ERECTION BOLTS
  - 2) ALL HOT DIP GALVANIZED AFTER FABRICATION (ASTM A123)
  - 3) ALL HOLES 11/16" DIA. FOR 5/8" DIA. BOLTS UNLESS NOTED
  - 4) PIECE MARK STAMPED INTO METAL WITH NOT LESS THAN 3/8" HIGH CHARACTERS BEFORE GALVANIZING
  - 5) ALL WELDING ELECTRODES SHALL BE E7021
  - 6) EDGE DISTANCE 1" UNLESS NOTED
  - 7) ERECTION BOLT LENGTH VARIES WHERE NOTED. B2 TO BE USED IN CASES WHERE A SINGLE TRUSS IS CONNECTED TO COLUMN. B-4 TO BE USED IN CASES WHERE TWO TRUSSES ARE CONNECTED TO COLUMN.

BILL OF MATERIAL				
POS. NO.	QTY	DESC.	LENGTH	WEIGHT
<b>G104</b>	<b>2</b>	<b>FOR ONE GROUP G104</b>		
ANG141	1	L3x2-1/2x1/4	1'-0 3/4"	4.78
ANG150	2	L3x2x3/16	4 3/4"	2.43
BASE138	1	PL 1 1/4"x1'-4"	1'-4"	90.93
C104	1	W8x24	21'-10 1/4"	524.50
PL152	1	PL 3/4"x1'-1"	1'-1"	36.01
			BLACK WEIGHT:	658.65 LBS.
			GALVANIZED WEIGHT:	26.35 LBS.
			TOTAL WEIGHT:	685.00 LBS.

SEE DRAWING No. LS-11 FOR ANG141, ANG150, BASE138 & PL152 DETAILS AND NOTES.

G104  
SCALE: 1/2"=1'-0"

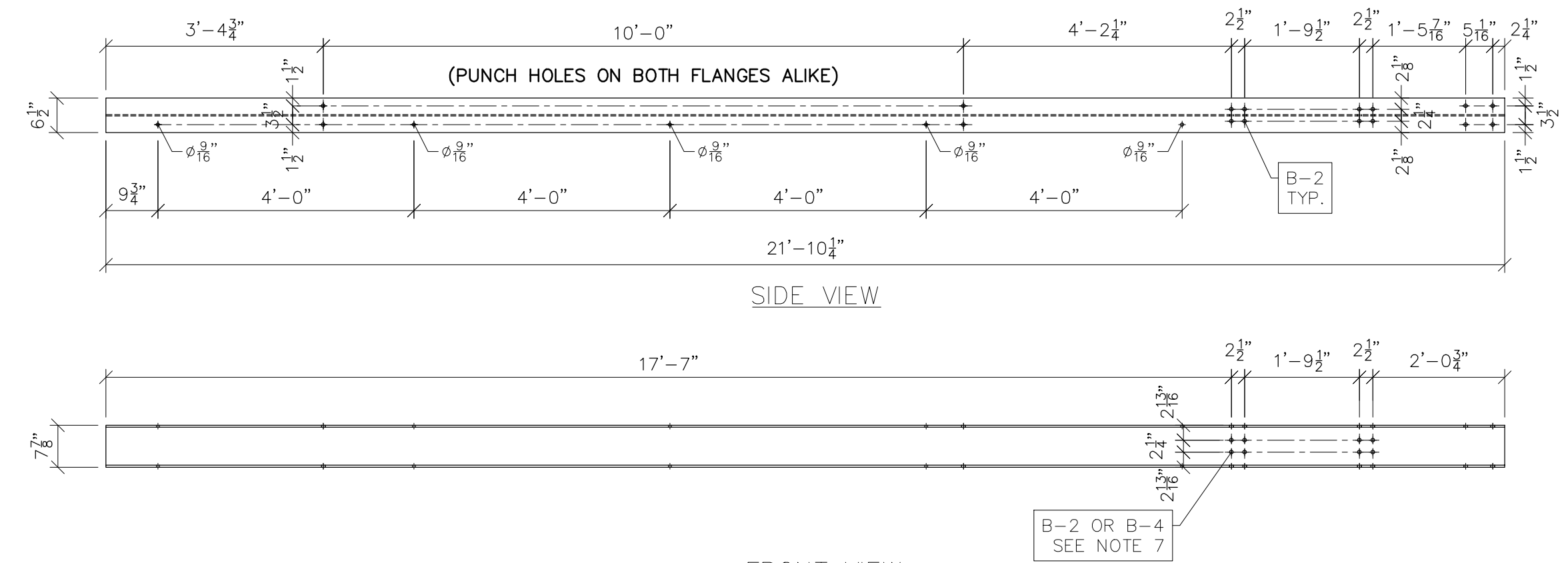

FRONT VIEW

C104  
SCALE: 1/2"=1'-0"



Booth & Associates  
2200 Remwood Drive Suite 300, Raleigh NC 27607  
N.C.F. 0021



PRELIMINARY -  
DO NOT USE FOR  
CONSTRUCTION

© 05/2023

NO.	ISSUED FOR BID	REVISIONS	ENG.	DATE
A			VK	06/10/2023

PROJECT NAME: CUMBERLAND ROAD  
69 TO 15 X 25 kV  
SUBSTATION

DRAWING TITLE:  
LOW SIDE DETAILS (TRUSSES)

DRAWN BY:	DJD
CHECKED BY:	VK
APPROVED BY:	VK
DATE:	05/10/2023
SCALE:	AS SHOWN
FILE NUMBER:	12510
SHEET:	

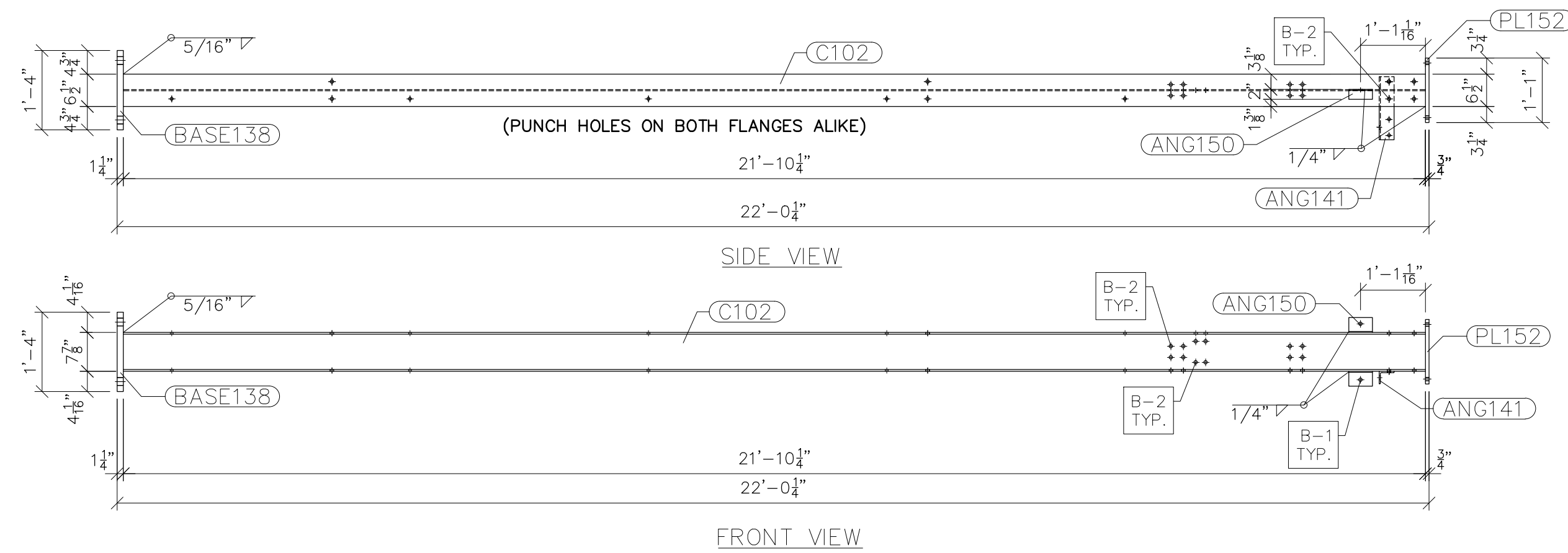

G102  
SCALE: 1/2"=1'-0"

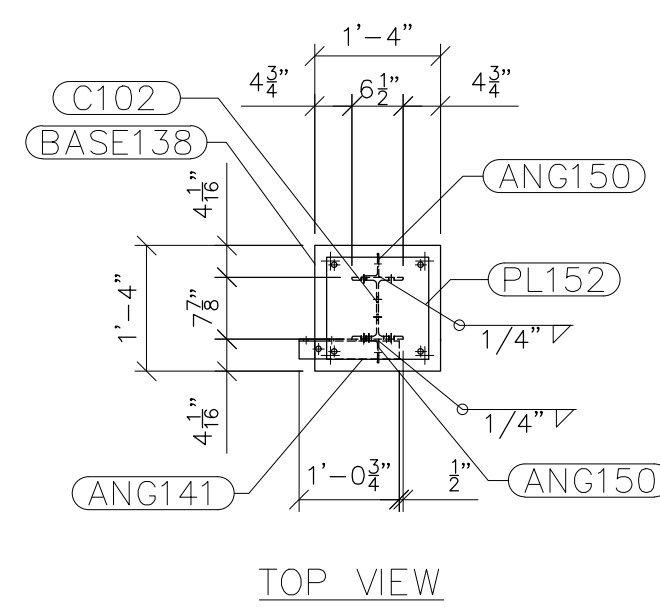

TOP VIEW

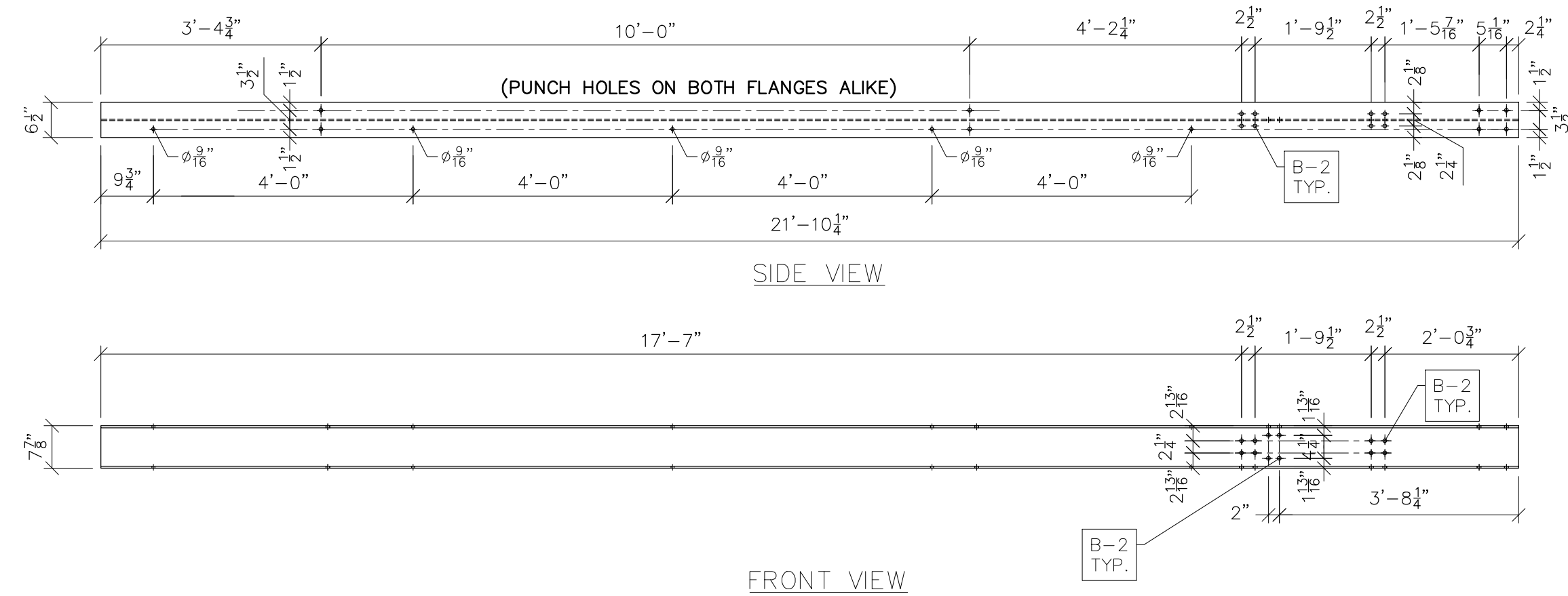

C102  
SCALE: 1/2"=1'-0"

- NOTES:
- 1) ASTM 325 ERECTION BOLTS
  - 2) ALL HOT DIP GALVANIZED AFTER FABRICATION (ASTM A123)
  - 3) ALL HOLES 11/16" DIA. FOR 5/8" DIA. BOLTS UNLESS NOTED
  - 4) PIECE MARK STAMPED INTO METAL WITH NOT LESS THAN 3/8" HIGH CHARACTERS BEFORE GALVANIZING
  - 5) ALL WELDING ELECTRODES SHALL BE E7021
  - 6) EDGE DISTANCE 1" UNLESS NOTED

BILL OF MATERIAL				
POS. NO.	QTY	DESC	LENGTH	WEIGHT
<b>G102</b>	<b>3</b>	<b>FOR ONE GROUP G102</b>		
ANG141	1	L3x2-1/2x1/4	1'-0 3/4"	4.78
ANG150	2	L3x2x3/16	4 3/4"	2.43
BASE138	1	PL 1 1/4"x1'-4"	1'-4"	90.93
C102	1	W8x24	21'-10 1/4"	524.50
PL152	1	PL 3/4"x1'-1"	1'-1"	36.01
BLACK WEIGHT:			658.65	LBS.
GALVANIZED WEIGHT:			26.35	LBS.
TOTAL WEIGHT:			685.00	LBS.

SEE DRAWING No. LS-11 FOR ANG141, ANG150, BASE138 & PL152 DETAILS AND NOTES.



PRELIMINARY - DO NOT USE FOR CONSTRUCTION

© 05/2023

NO.	REVISIONS	ENG.	DATE
A	ISSUED FOR BID	VK	06/10/2023

PROJECT NAME: CUMBERLAND ROAD 69 TO 15 X 25 kV SUBSTATION  
DRAWING TITLE: LOW SIDE DETAILS (TRUSSES)

DRAWN BY: DJD  
CHECKED BY: VK  
APPROVED BY: VK  
DATE: 05/10/2023  
SCALE: AS SHOWN  
FILE NUMBER: 12510  
SHEET:



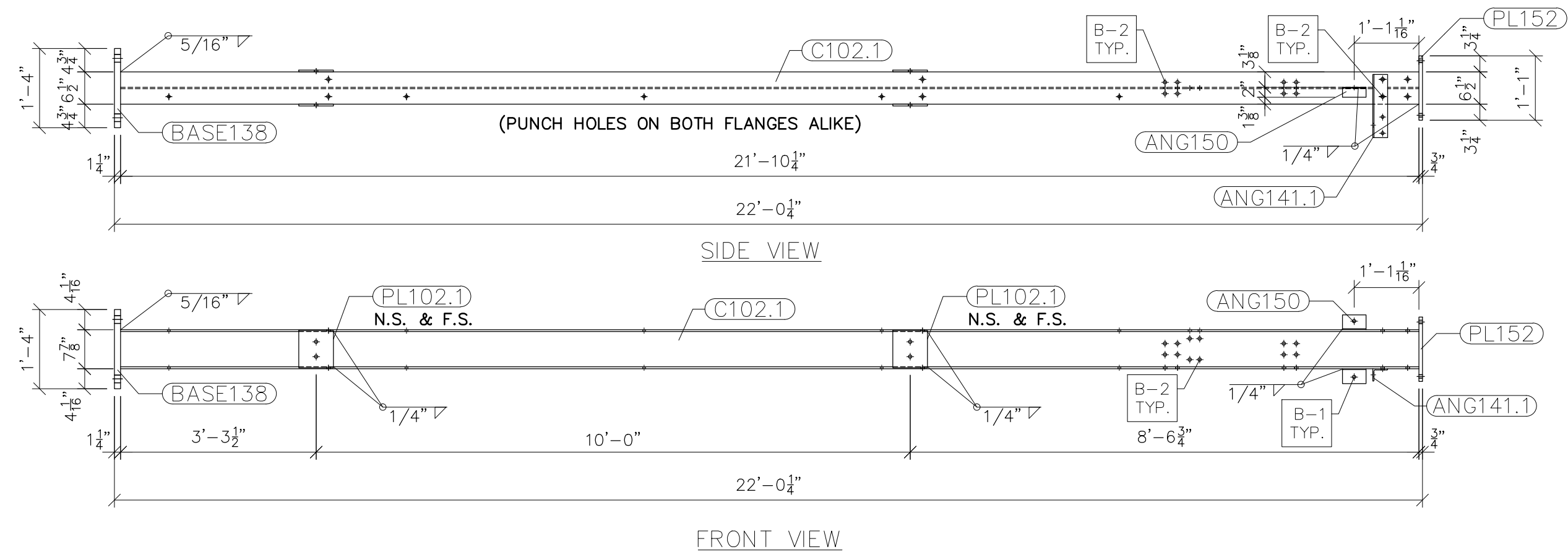

G102.1  
SCALE: 1/2"=1'-0"

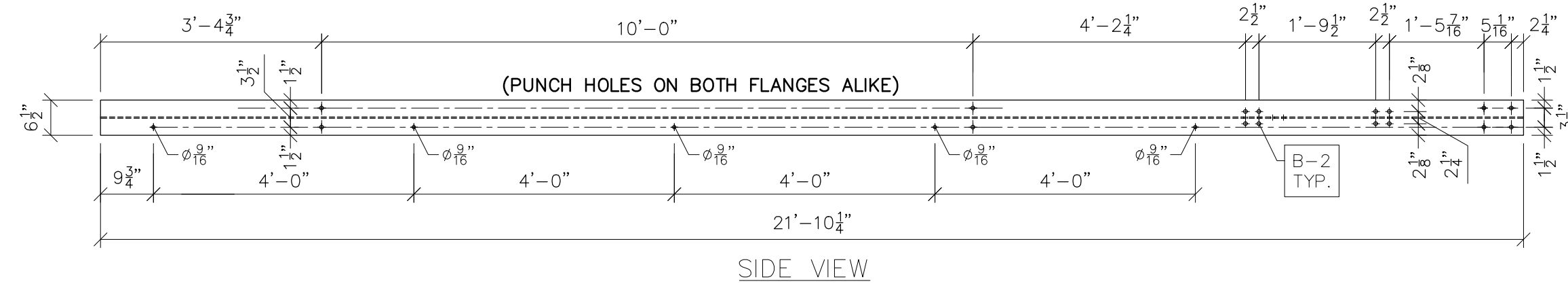

C102.1  
SCALE: 1/2"=1'-0"

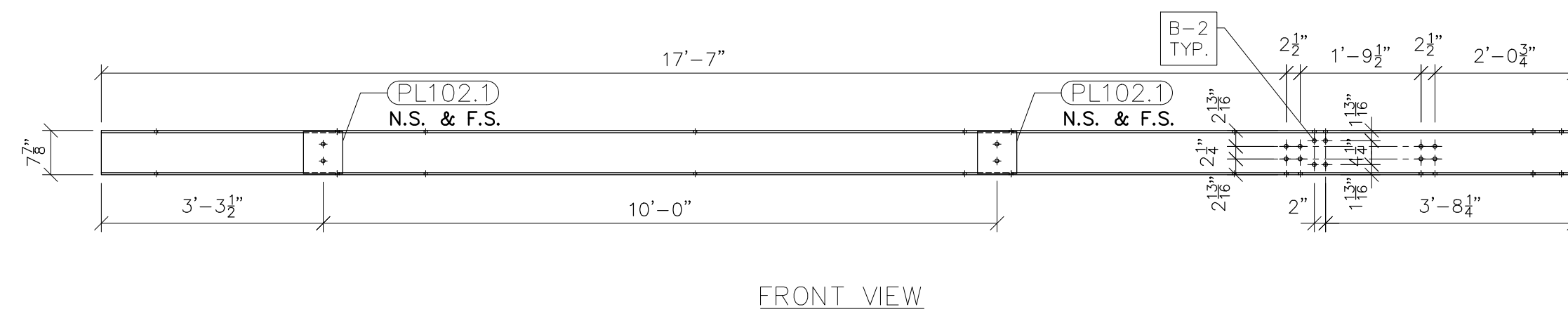

C102.1  
SCALE: 1/2"=1'-0"

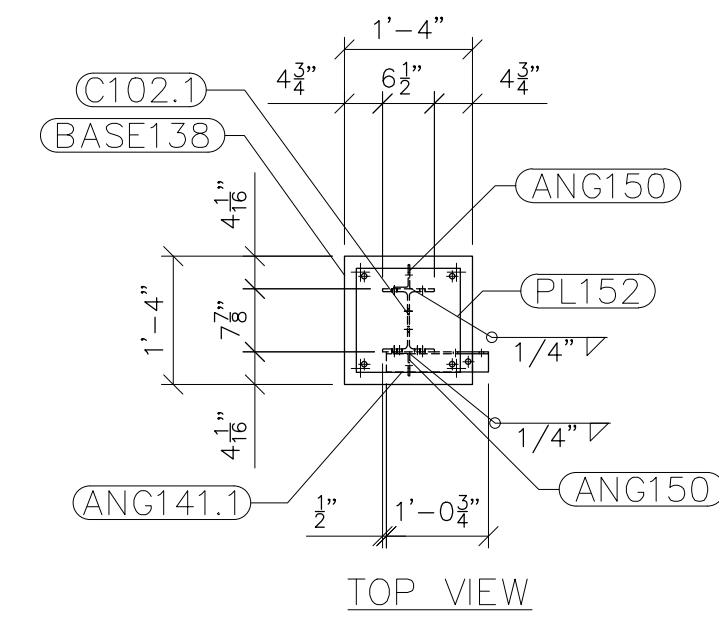

TOP VIEW

- NOTES:
- 1) ASTM 325 ERECTION BOLTS
  - 2) ALL HOT DIP GALVANIZED AFTER FABRICATION (ASTM A123)
  - 3) ALL HOLES 11/16" DIA. FOR 5/8" DIA. BOLTS UNLESS NOTED
  - 4) PIECE MARK STAMPED INTO METAL WITH NOT LESS THAN 3/8" HIGH CHARACTERS BEFORE GALVANIZING
  - 5) ALL WELDING ELECTRODES SHALL BE E7021
  - 6) EDGE DISTANCE 1" UNLESS NOTED

BILL OF MATERIAL				
POS. NO.	QTY	DESC.	LENGTH	WEIGHT
<b>G102.1 FOR ONE GROUP G102.1</b>				
ANG141.1	1	L3x2-1/2x1/4	1'-0 3/4"	4.78
ANG150	2	L3x2x3/16	4 3/4"	2.43
BASE138	1	PL 1 1/4"x1'-4"	1'-4"	90.93
C102.1	1	W8x24	21'-10 1/4"	524.50
PL152	1	PL 3/4"x1'-1"	1'-1"	36.01
PL102.1	4	PL 3/8"x7"	7 1/2"	22.34
BLACK WEIGHT:			680.99 LBS.	
GALVANIZED WEIGHT:			27.24 LBS.	
TOTAL WEIGHT:			708.23 LBS.	

SEE DRAWING No. LS-11 FOR ANG141.1, ANG150, BASE138 & PL152 DETAILS AND NOTES.



PRELIMINARY - DO NOT USE FOR CONSTRUCTION

© 05/2023

NO.	REVISIONS	ENG.	DATE
A	ISSUED FOR BID	VK	06/10/2023

PROJECT NAME:	CUMBERLAND ROAD 69 TO 15 X 25 kV SUBSTATION
DRAWING TITLE:	LOW SIDE DETAILS (TRUSSES)
DRAWN BY:	DJD
CHECKED BY:	VK
APPROVED BY:	VK
DATE:	05/10/2023
SCALE:	AS SHOWN
FILE NUMBER:	12510
SHEET:	

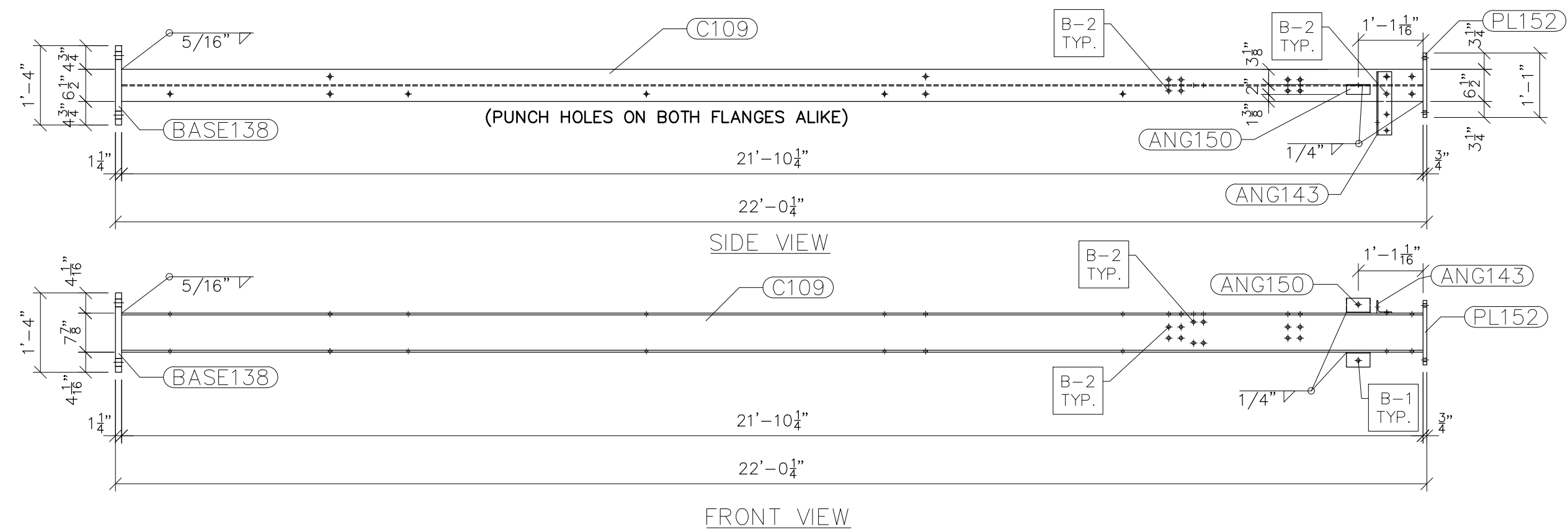

G109  
SCALE: 1/2"=1'-0"

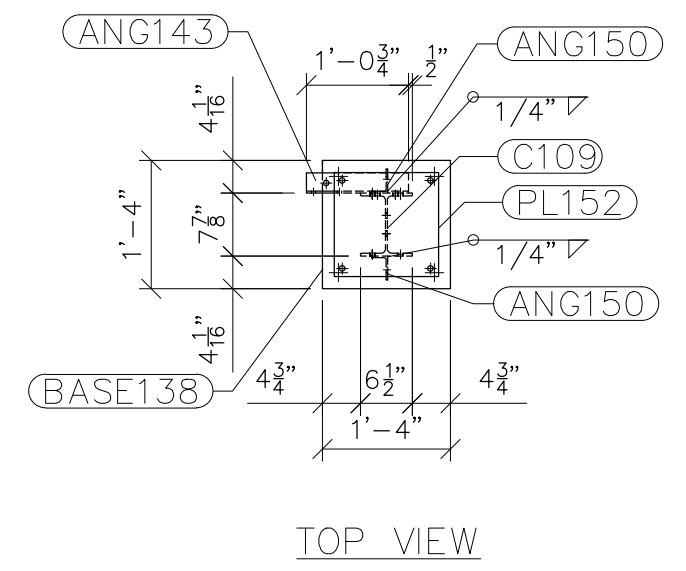

TOP VIEW

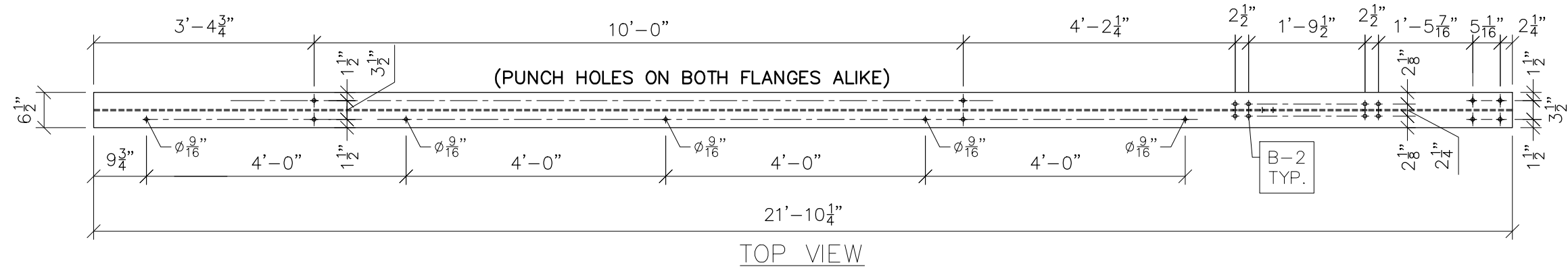

TOP VIEW

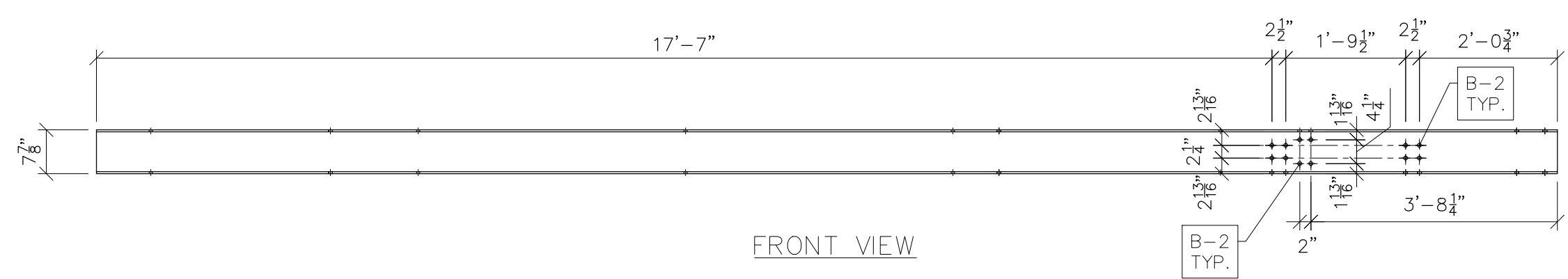

FRONT VIEW

C109  
SCALE: 1/2"=1'-0"

- NOTES:
- 1) ASTM 325 ERECTION BOLTS
  - 2) ALL HOT DIP GALVANIZED AFTER FABRICATION (ASTM A123)
  - 3) ALL HOLES 11/16" DIA. FOR 5/8" DIA. BOLTS UNLESS NOTED
  - 4) PIECE MARK STAMPED INTO METAL WITH NOT LESS THAN 3/8" HIGH CHARACTERS BEFORE GALVANIZING
  - 5) ALL WELDING ELECTRODES SHALL BE E7021
  - 6) EDGE DISTANCE 1" UNLESS NOTED

BILL OF MATERIAL				
POS. NO.	QTY	DESC.	LENGTH	WEIGHT
G109	4	FOR ONE GROUP G109		
ANG143	1	L3x2-1/2x1/4	1'-0 3/4"	4.78
ANG150	2	L3x2x3/16	4 3/4"	2.43
BASE138	1	PL 1 1/4"x1'-4"	1'-4"	90.93
C109	1	W8x24	21'-10 1/4"	524.50
PL152	1	PL 3/4"x1'-1"	1'-1"	36.01
BLACK WEIGHT:			658.65	LBS.
GALVANIZED WEIGHT:			26.35	LBS.
TOTAL WEIGHT:			685.00	LBS.

SEE DRAWING No. LS-11 FOR ANG143, ANG150, BASE138 & PL152 DETAILS AND NOTES.



Booth & Associates  
2200 Renwood Drive Suite 300, Raleigh NC 27607  
N.C. F. 0221



PRELIMINARY -  
DO NOT USE FOR  
CONSTRUCTION

© 05/2023

NO.	REVISIONS	ENG.	DATE
A	ISSUED FOR BID	VK	06/10/2023

PROJECT NAME: CUMBERLAND ROAD  
69 TO 15 X 25 kV  
SUBSTATION

DRAWING TITLE:  
LOW SIDE DETAILS (TRUSSES)

DRAWN BY: DJD  
CHECKED BY: VK  
APPROVED BY: VK  
DATE: 05/10/2023  
SCALE: AS SHOWN  
FILE NUMBER: 12510  
SHEET:

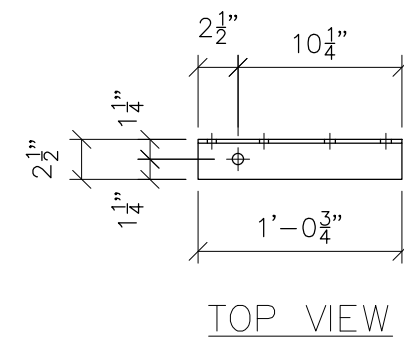

TOP VIEW

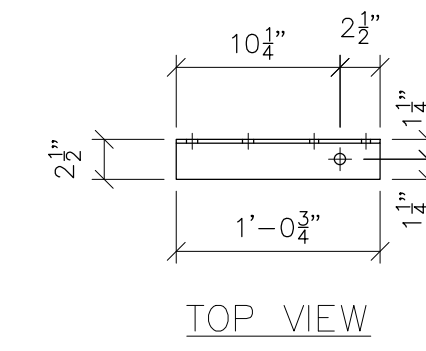

TOP VIEW

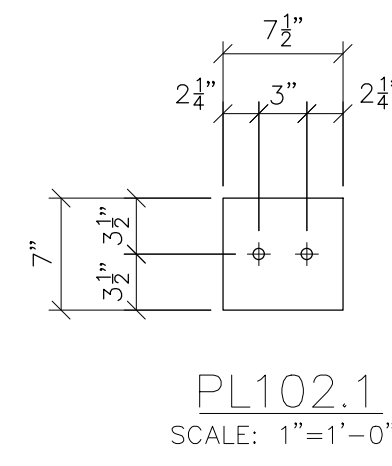

PL102.1  
SCALE: 1"=1'-0"

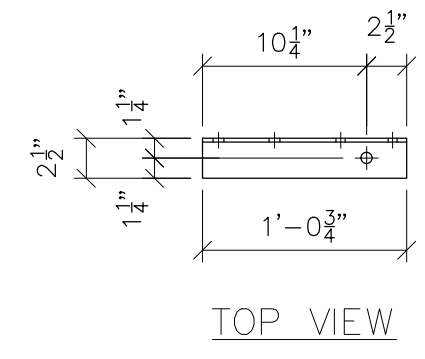

TOP VIEW

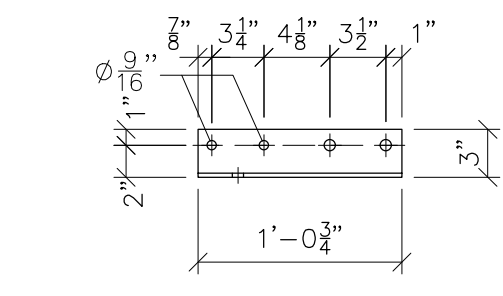

FRONT VIEW  
ANG141  
SCALE: 1"=1'-0"

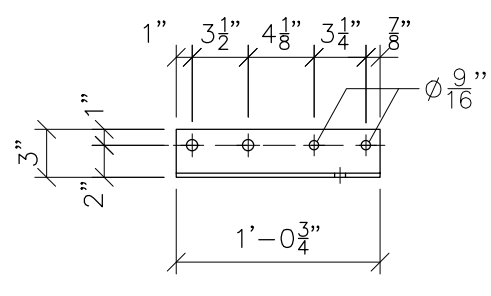

FRONT VIEW  
ANG143  
SCALE: 1"=1'-0"

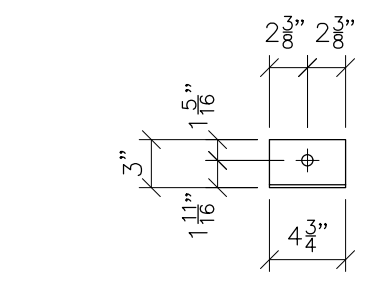

ANG150 FRONT VIEW  
SCALE: 1"=1'-0"

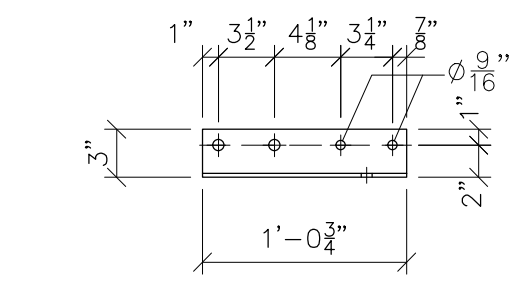

FRONT VIEW  
ANG141.1  
SCALE: 1"=1'-0"

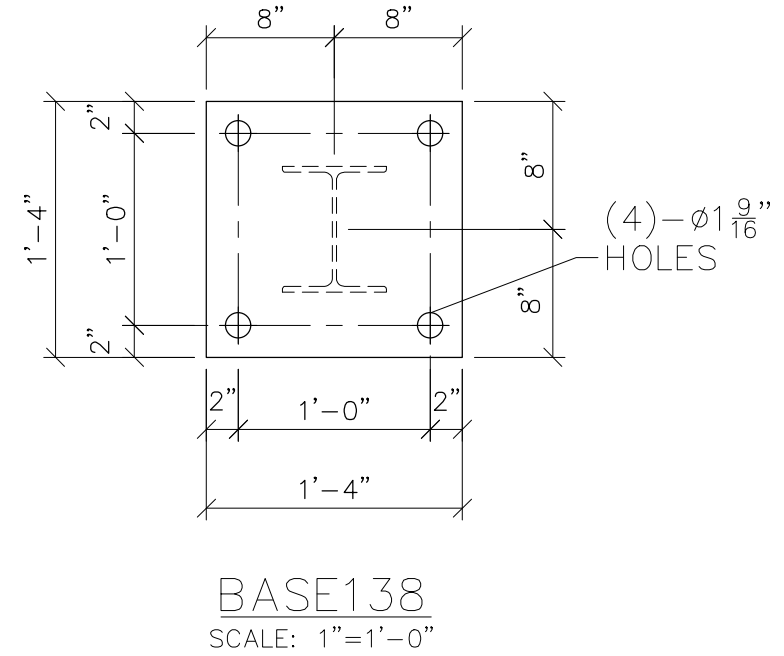

BASE138  
SCALE: 1"=1'-0"

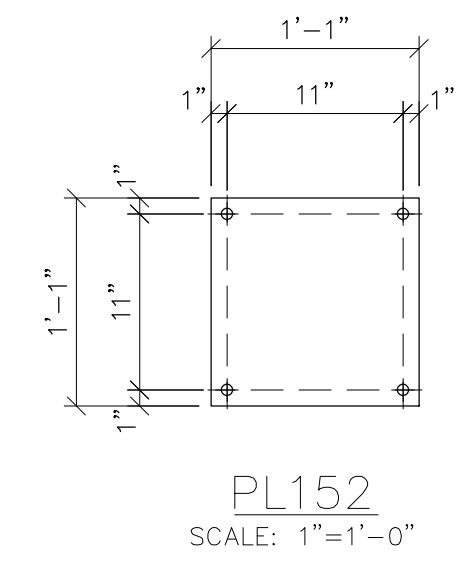

PL152  
SCALE: 1"=1'-0"

- NOTES:
- 1) ASTM 325 ERECTION BOLTS
  - 2) ALL HOT DIP GALVANIZED AFTER FABRICATION (ASTM A123)
  - 3) ALL HOLES 11/16" DIA. FOR 5/8" DIA. BOLTS UNLESS NOTED
  - 4) PIECE MARK STAMPED INTO METAL WITH NOT LESS THAN 3/8" HIGH CHARACTERS BEFORE GALVANIZING
  - 5) ALL WELDING ELECTRODES SHALL BE E7021
  - 6) EDGE DISTANCE 1" UNLESS NOTED
  - 7) ERECTION BOLT LENGTH VARIES WHERE NOTED. B2 TO BE USED IN CASES WHERE A SINGLE TRUSS IS CONNECTED TO COLUMN. B-4 TO BE USED IN CASES WHERE TWO TRUSSES ARE CONNECTED TO COLUMN.



PRELIMINARY -  
DO NOT USE FOR  
CONSTRUCTION

© 05/2023

NO.	REVISIONS	ENG.	DATE
A	ISSUED FOR BID	VK	06/10/2023

PROJECT NAME:	CUMBERLAND ROAD 69 TO 15 X 25 kV SUBSTATION
DRAWING TITLE:	LOW SIDE DETAILS (TRUSSES)
DRAWN BY:	DJD
CHECKED BY:	VK
APPROVED BY:	VK
DATE:	05/10/2023
SCALE:	AS SHOWN
FILE NUMBER:	12510
SHEET:	

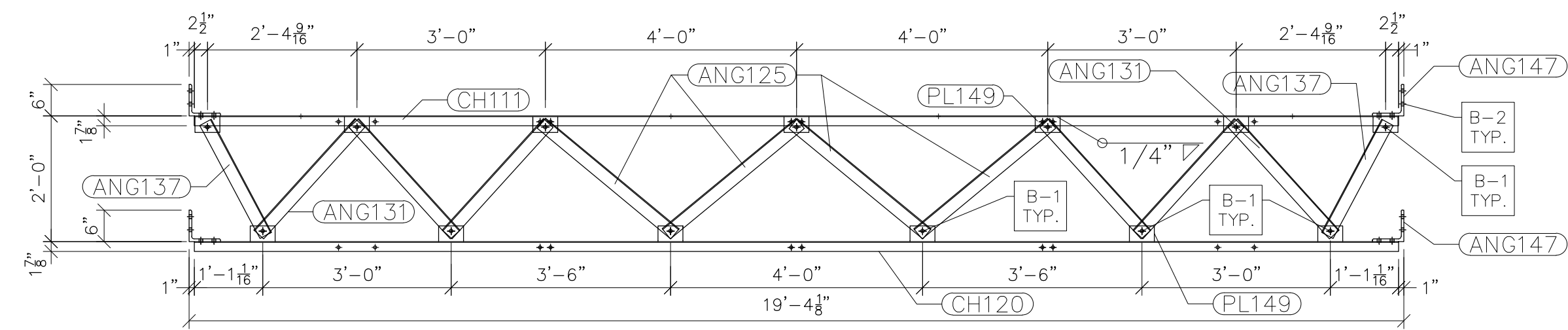

NOTE: PL149 IS WELDED TO CENTER OF CHANNEL

G111 FRONT VIEW  
SCALE: 1/2"=1'-0"

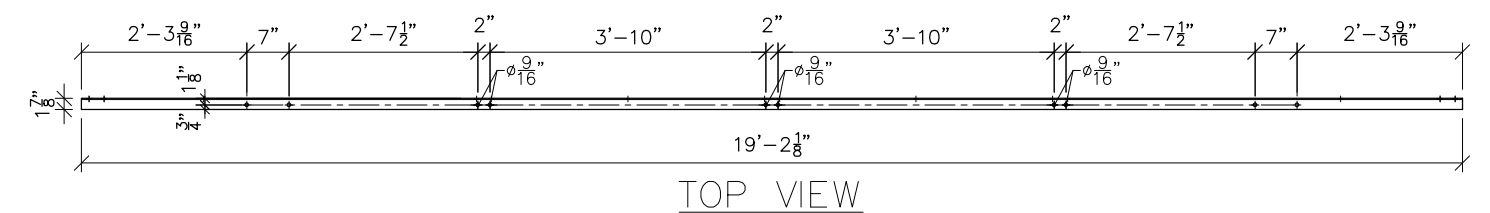

TOP VIEW

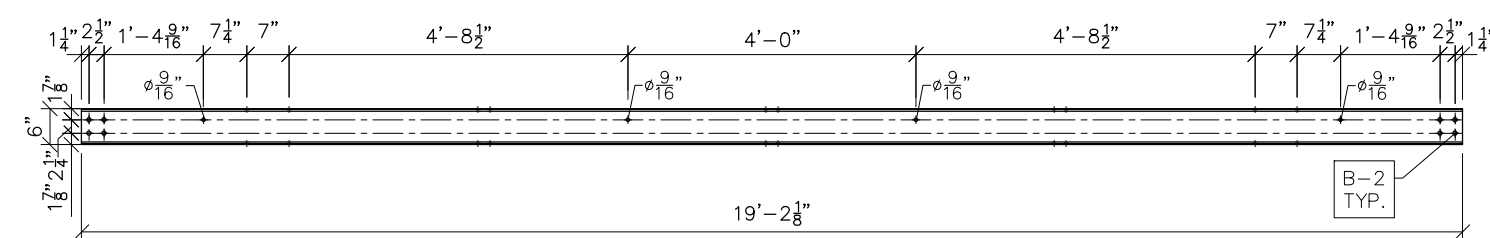

FRONT VIEW

CH111  
SCALE: 3/8"=1'-0"

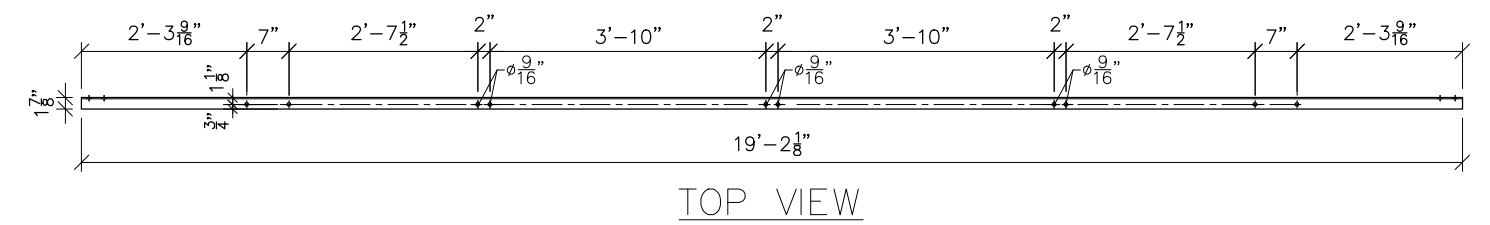

TOP VIEW

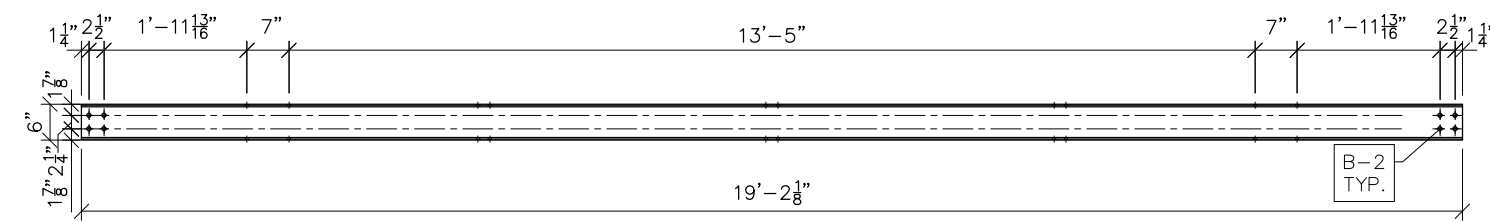

FRONT VIEW

CH120  
SCALE: 3/8"=1'-0"

NOTES:

- 1) ASTM 325 ERECTION BOLTS
- 2) ALL HOT DIP GALVANIZED AFTER FABRICATION (ASTM A123)
- 3) ALL HOLES 11/16" DIA. FOR 5/8" DIA. BOLTS UNLESS NOTED
- 4) PIECE MARK STAMPED INTO METAL WITH NOT LESS THAN 3/8" HIGH CHARACTERS BEFORE GALVANIZING
- 5) ALL WELDING ELECTRODES SHALL BE E7021
- 6) EDGE DISTANCE 1" UNLESS NOTED

BILL OF MATERIAL				
POS. NO.	QTY	DESC.	LENGTH	WEIGHT
<b>G111</b>	<b>3</b>	<b>FOR ONE GROUP G111</b>		
ANG125	4	L2-1/2x2-1/2x3/16	2'-9 3/16"	33.96
ANG131	6	L2-1/2x2-1/2x3/16	2'-4 3/4"	44.16
ANG137	2	L2-1/2x2-1/2x3/16	2'-0 7/16"	12.50
ANG147	4	L6x6x1/2	6"	39.18
CH111	1	C6x8.2	19'-2 1/8"	157.25
CH120	1	C6x8.2	19'-2 1/8"	157.25
PL149	13	PL 1/4" x 4 3/4"	3"	13.15
			BLACK WEIGHT:	457.45 LBS.
			GALVANIZED WEIGHT:	18.30 LBS.
			TOTAL WEIGHT:	475.75 LBS.

SEE DRAWING No. LS-15 FOR ANG125, ANG131, ANG137, ANG147 & PL149 DETAILS.



PRELIMINARY -  
DO NOT USE FOR  
CONSTRUCTION

© 05/2023

NO.	REVISIONS	ENG.	DATE
A	ISSUED FOR BID	VK	06/10/2023

PROJECT NAME:	CUMBERLAND ROAD 69 TO 15 X 25 kV SUBSTATION
DRAWING TITLE:	LOW SIDE DETAILS (TRUSSES)
DRAWN BY:	DJD
CHECKED BY:	VK
APPROVED BY:	VK
DATE:	05/10/2023
SCALE:	AS SHOWN
FILE NUMBER:	12510
SHEET:	

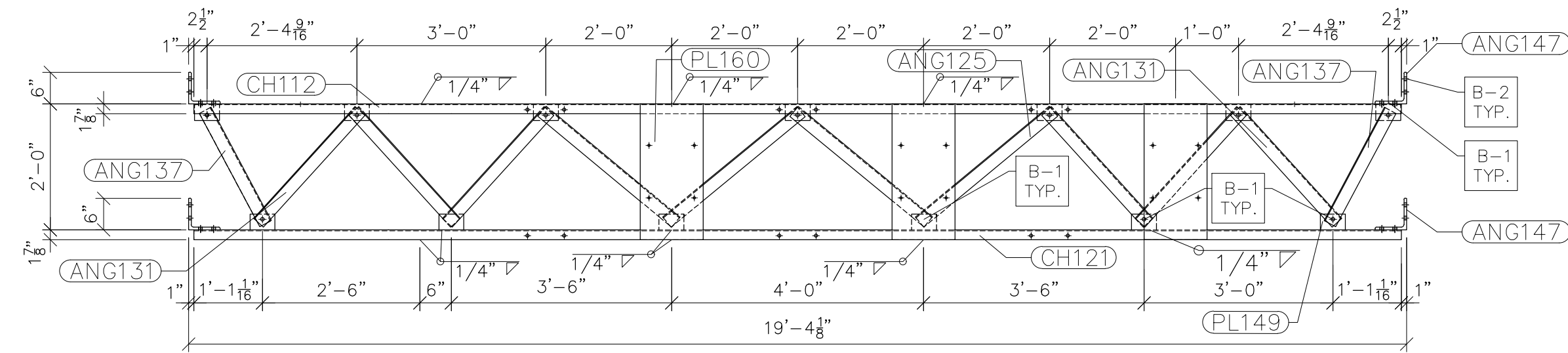

NOTE: PL149 IS WELDED TO CENTER OF CHANNEL

G112 FRONT VIEW  
SCALE: 1/2"=1'-0"

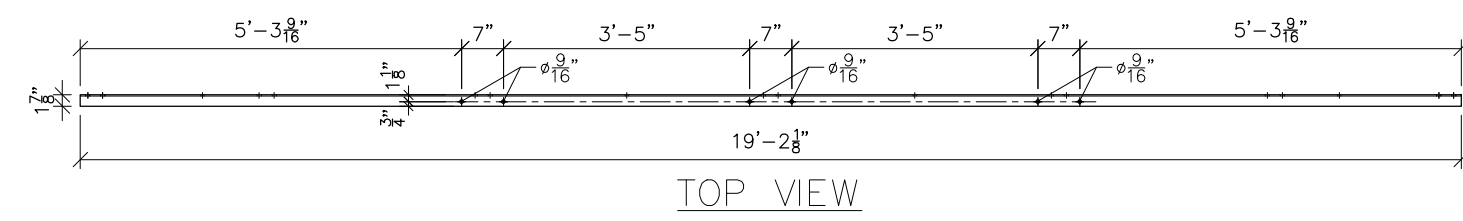

TOP VIEW

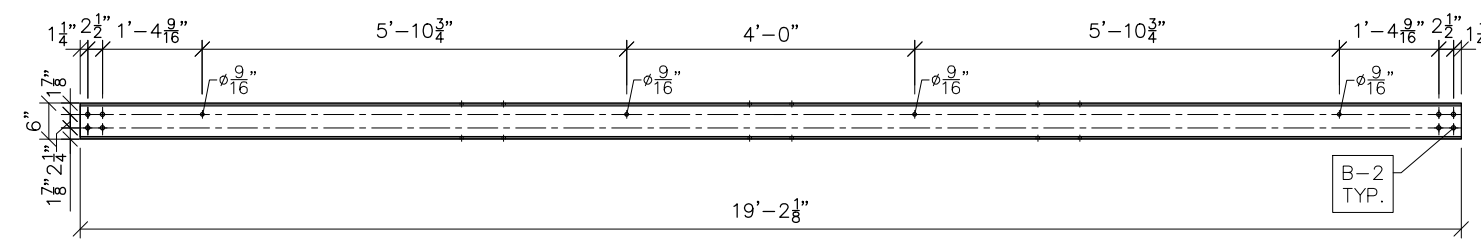

FRONT VIEW

CH112  
SCALE: 3/8"=1'-0"

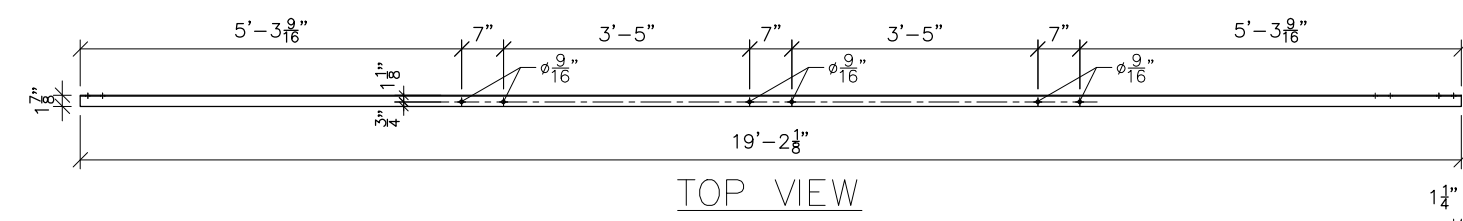

TOP VIEW

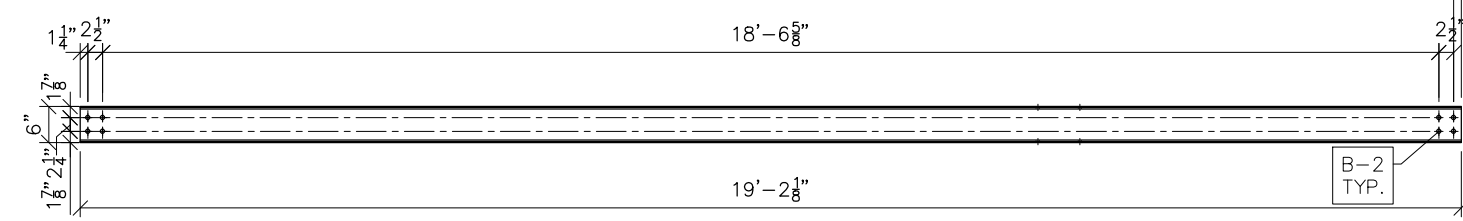

FRONT VIEW

CH121  
SCALE: 3/8"=1'-0"

NOTES:

- 1) ASTM 325 ERECTION BOLTS
- 2) ALL HOT DIP GALVANIZED AFTER FABRICATION (ASTM A123)
- 3) ALL HOLES 11/16" DIA. FOR 5/8" DIA. BOLTS UNLESS NOTED
- 4) PIECE MARK STAMPED INTO METAL WITH NOT LESS THAN 3/8" HIGH CHARACTERS BEFORE GALVANIZING
- 5) ALL WELDING ELECTRODES SHALL BE E7021
- 6) EDGE DISTANCE 1" UNLESS NOTED

BILL OF MATERIAL				
POS. NO.	QTY	DESC.	LENGTH	WEIGHT
<b>G112</b>	<b>1</b>	<b>FOR ONE GROUP G112:</b>		
ANG125	4	L2-1/2x2-1/2x3/16	2'-9 3/16"	33.96
ANG131	6	L2-1/2x2-1/2x3/16	2'-4 3/4"	44.16
ANG137	2	L2-1/2x2-1/2x3/16	2'-0 7/16"	12.50
ANG147	4	L6x6x1/2	6"	39.18
PL149	13	PL 1/4" x 4 3/4"	3"	13.15
CH112	1	C6x8.2	19'-2 1/8"	157.25
CH121	1	C6x8.2	19'-2 1/8"	157.25
PL160	3	PL 1/4"x1'-0"	2'-1 7/8"	66.17
BLACK WEIGHT:				523.62 LBS.
GALVANIZED WEIGHT:				20.95 LBS.
TOTAL WEIGHT:				544.57 LBS.

SEE DRAWING No. LS-15 FOR ANG125, ANG131, ANG137, ANG147, PL149 & PL152 DETAILS.



PRELIMINARY -  
DO NOT USE FOR  
CONSTRUCTION

© 05/2023

NO.	REVISIONS	ENG.	DATE
A	ISSUED FOR BID	VK	06/10/2023

PROJECT NAME: CUMBERLAND ROAD  
69 TO 15 X 25 kV  
SUBSTATION

DRAWING TITLE:  
LOW SIDE DETAILS (TRUSSES)

DRAWN BY:	DJD
CHECKED BY:	VK
APPROVED BY:	VK
DATE:	05/10/2023
SCALE:	AS SHOWN
FILE NUMBER:	12510
SHEET:	

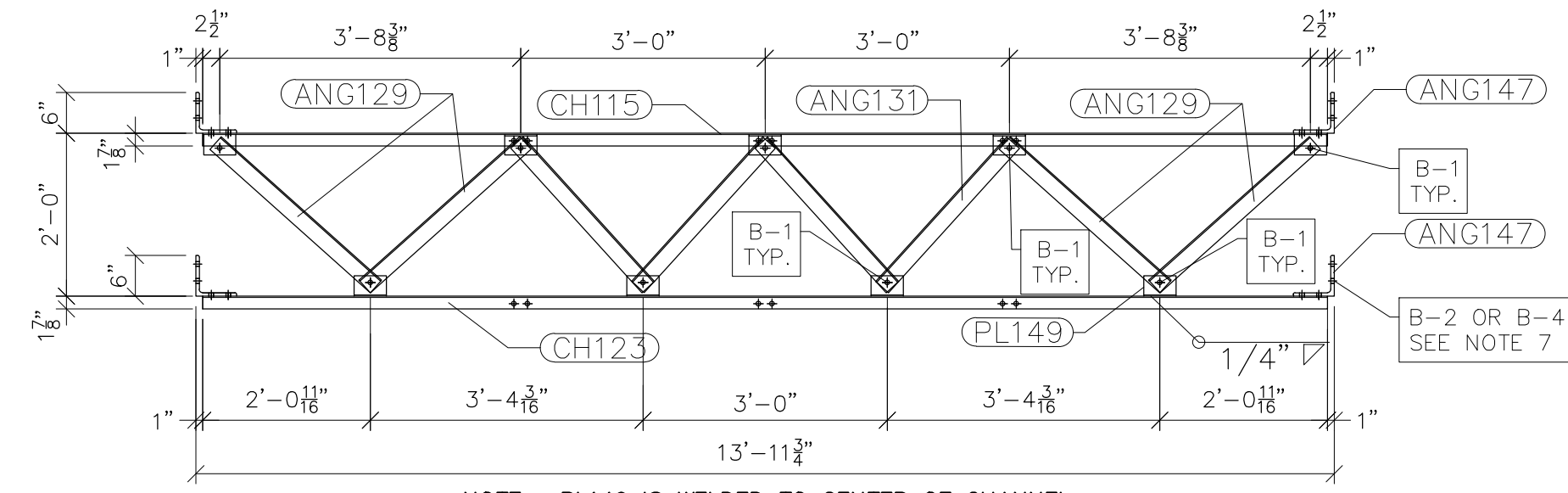

G115 FRONT VIEW  
SCALE: 1/2"=1'-0"

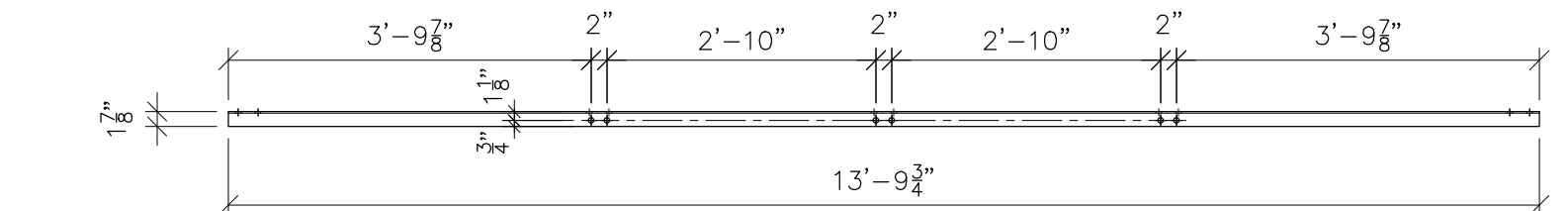

TOP VIEW

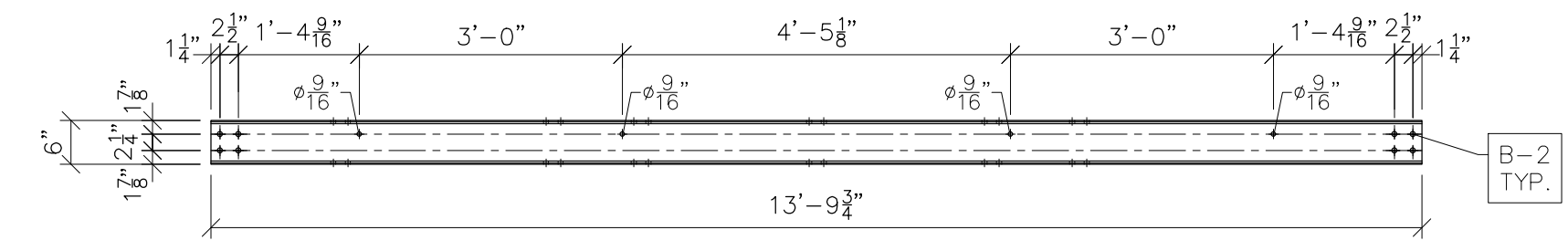

FRONT VIEW  
CH115  
SCALE: 1/2"=1'-0"

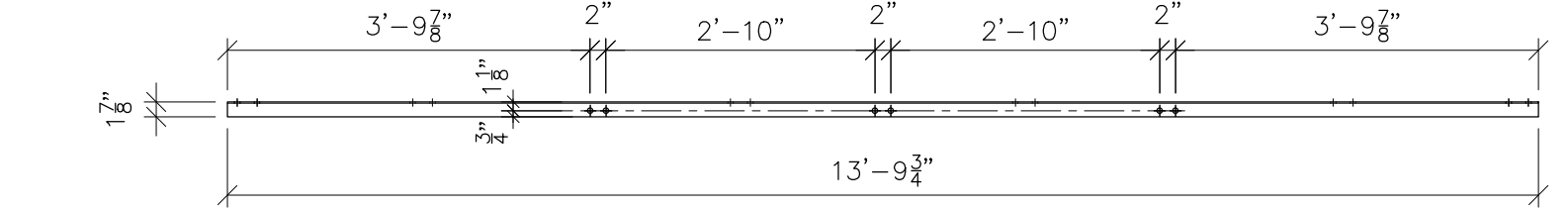

TOP VIEW

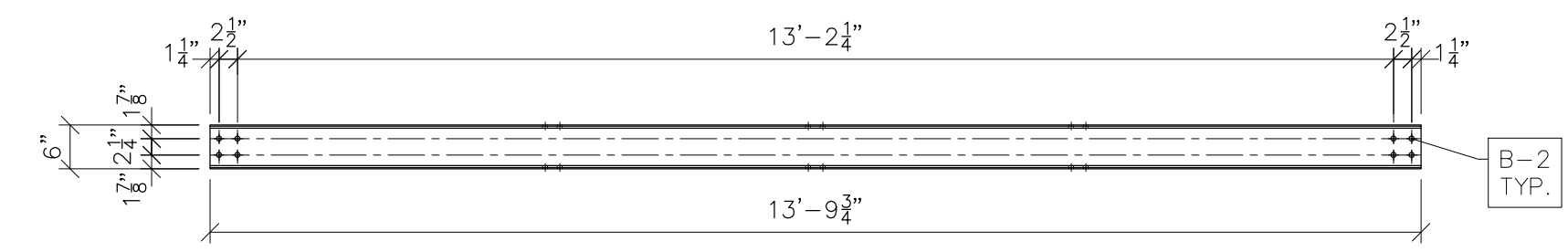

FRONT VIEW  
CH123  
SCALE: 1/2"=1'-0"

- NOTES:
- 1) ASTM 325 ERECTION BOLTS
  - 2) ALL HOT DIP GALVANIZED AFTER FABRICATION (ASTM A123)
  - 3) ALL HOLES 11/16" DIA. FOR 5/8" DIA. BOLTS UNLESS NOTED
  - 4) PIECE MARK STAMPED INTO METAL WITH NOT LESS THAN 3/8" HIGH CHARACTERS BEFORE GALVANIZING
  - 5) ALL WELDING ELECTRODES SHALL BE E7021
  - 6) EDGE DISTANCE 1" UNLESS NOTED
  - 7) ERECTION BOLT LENGTH VARIES WHERE NOTED. B2 TO BE USED IN CASES WHERE A SINGLE TRUSS IS CONNECTED TO COLUMN. B-4 TO BE USED IN CASES WHERE TWO TRUSSES ARE CONNECTED TO COLUMN.

BILL OF MATERIAL				
POS. NO.	QTY	DESC.	LENGTH	WEIGHT
<b>G115</b>	<b>6</b>	<b>FOR ONE GROUP G115</b>		
ANG129	4	L2-1/2x2-1/2x3/16	2'-7 3/4"	32.46
ANG131	4	L2-1/2x2-1/2x3/16	2'-4 3/4"	29.39
ANG147	4	L6x6x1/2	6"	39.18
PL149	9	PL 1/4" x 4 3/4"	3"	9.10
CH115	1	C6x8.2	13'-9 3/4"	113.26
CH123	1	C6x8.2	13'-9 3/4"	113.26
BLACK WEIGHT:				336.65 LBS.
GALVANIZED WEIGHT:				13.47 LBS.
TOTAL WEIGHT:				350.12 LBS.

SEE DRAWING No. LS-15 FOR ANG129, ANG131, ANG137 & PL149 DETAILS.



PRELIMINARY -  
DO NOT USE FOR  
CONSTRUCTION

© 05/2023

NO.	ISSUED FOR BID	REVISIONS	ENG.	DATE
A			VK	06/10/2023

PROJECT NAME:	CUMBERLAND ROAD 69 TO 15 X 25 kV SUBSTATION
DRAWING TITLE:	LOW SIDE DETAILS (TRUSSES)
DRAWN BY:	DJD
CHECKED BY:	VK
APPROVED BY:	VK
DATE:	05/10/2023
SCALE:	AS SHOWN
FILE NUMBER:	12510
SHEET:	

- NOTES:
- 1) ASTM 325 ERECTION BOLTS
  - 2) ALL HOT DIP GALVANIZED AFTER FABRICATION (ASTM A123)
  - 3) ALL HOLES 11/16" DIA. FOR 5/8" DIA. BOLTS UNLESS NOTED
  - 4) PIECE MARK STAMPED INTO METAL WITH NOT LESS THAN 3/8" HIGH CHARACTERS BEFORE GALVANIZING
  - 5) ALL WELDING ELECTRODES SHALL BE E7021
  - 6) EDGE DISTANCE 1" UNLESS NOTED

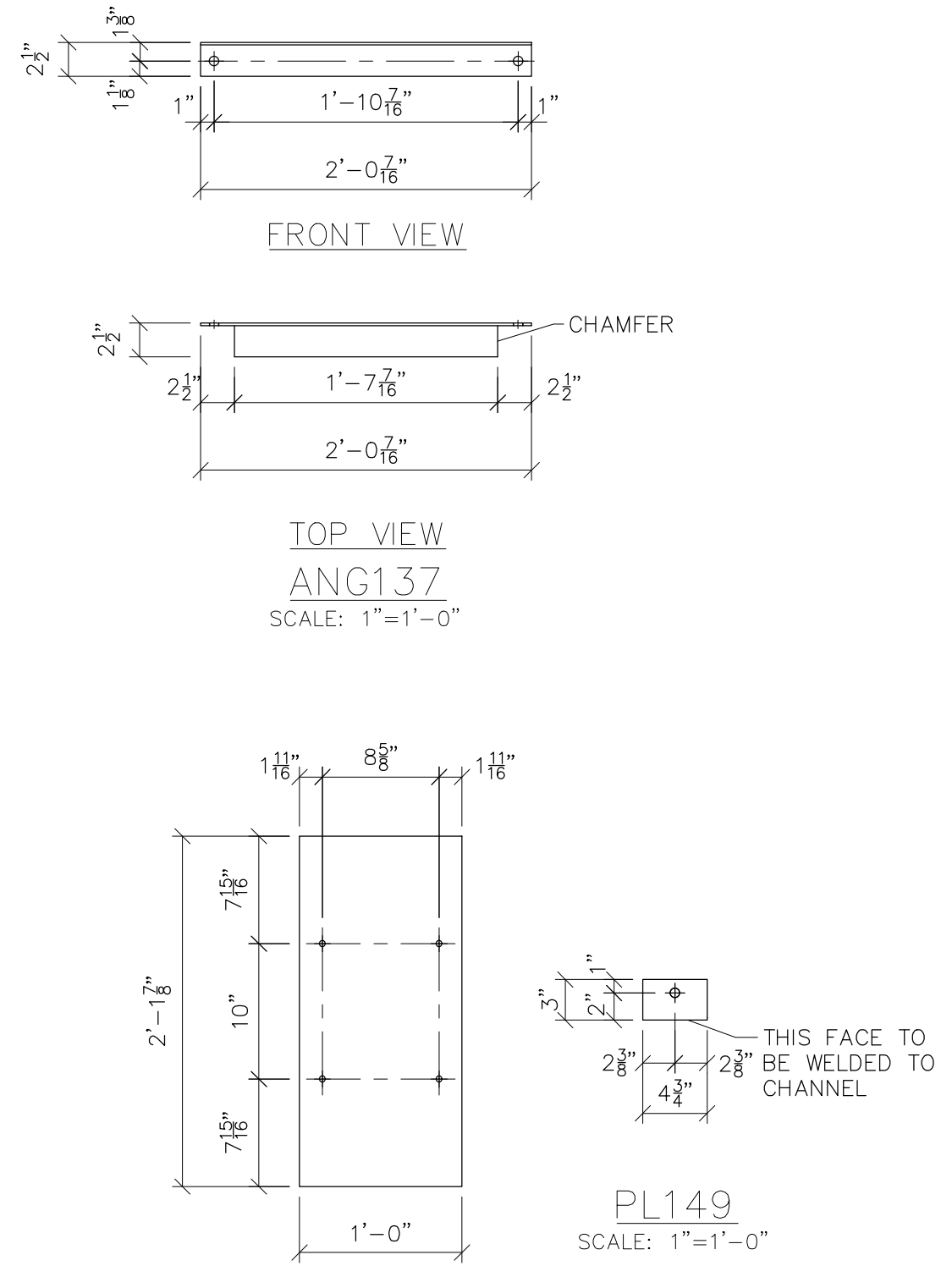
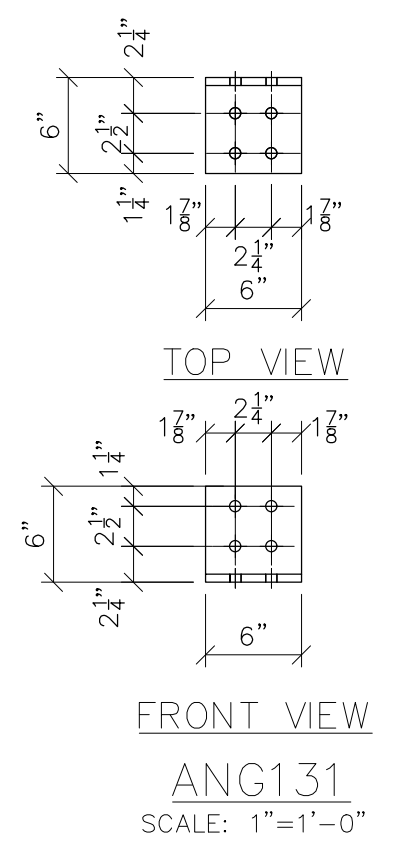
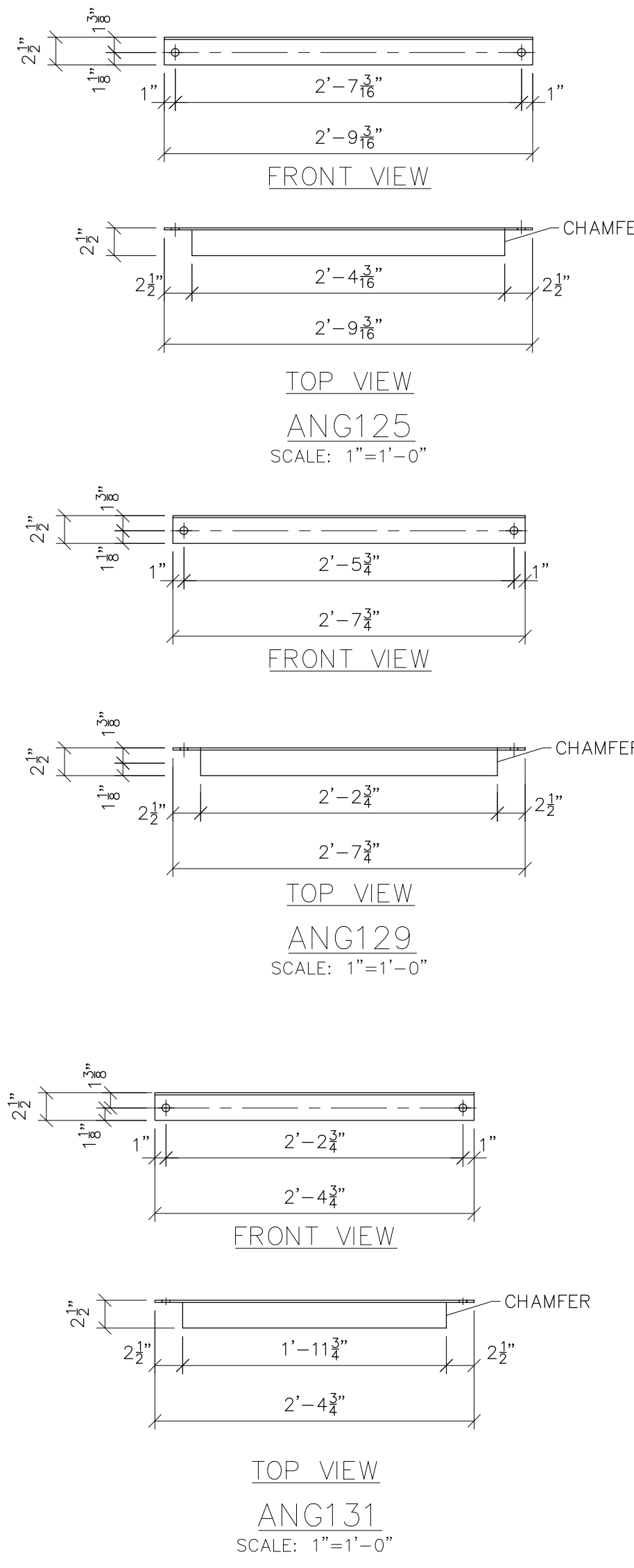





PRELIMINARY -  
DO NOT USE FOR  
CONSTRUCTION

NO.	REVISIONS	ENG.	DATE
A	ISSUED FOR BID	VK	06/10/2023

PROJECT NAME: CUMBERLAND ROAD  
69 TO 15 X 25 kV  
SUBSTATION

DRAWING TITLE:  
LOW SIDE DETAILS (TRUSSES)

© 05/2023

DRAWN BY: DJD	CHECKED BY: VK
APPROVED BY: VK	DATE: 05/10/2023
SCALE: AS SHOWN	FILE NUMBER: 12510
SHEET: LS-15	

- NOTES:
- 1) ASTM 325 ERECTION BOLTS
  - 2) ALL HOT DIP GALVANIZED AFTER FABRICATION (ASTM A123)
  - 3) ALL HOLES 11/16" DIA. FOR 5/8" DIA. BOLTS UNLESS NOTED
  - 4) PIECE MARK STAMPED INTO METAL WITH NOT LESS THAN 3/8" HIGH CHARACTERS BEFORE GALVANIZING
  - 5) ALL WELDING ELECTRODES SHALL BE E7021
  - 6) EDGE DISTANCE 1" UNLESS NOTED

BILL OF MATERIAL				
POS. NO.	QTY	DESC.	LENGTH	WEIGHT
G114	2	FOR ONE GROUP G114		
ANG157	4	L3x3x1/2	4"	12.53
B114	1	W6x15	13'-10 1/4"	207.81
BLACK WEIGHT:				220.34 LBS.
GALVANIZED WEIGHT:				8.81 LBS.
TOTAL WEIGHT:				229.15 LBS.

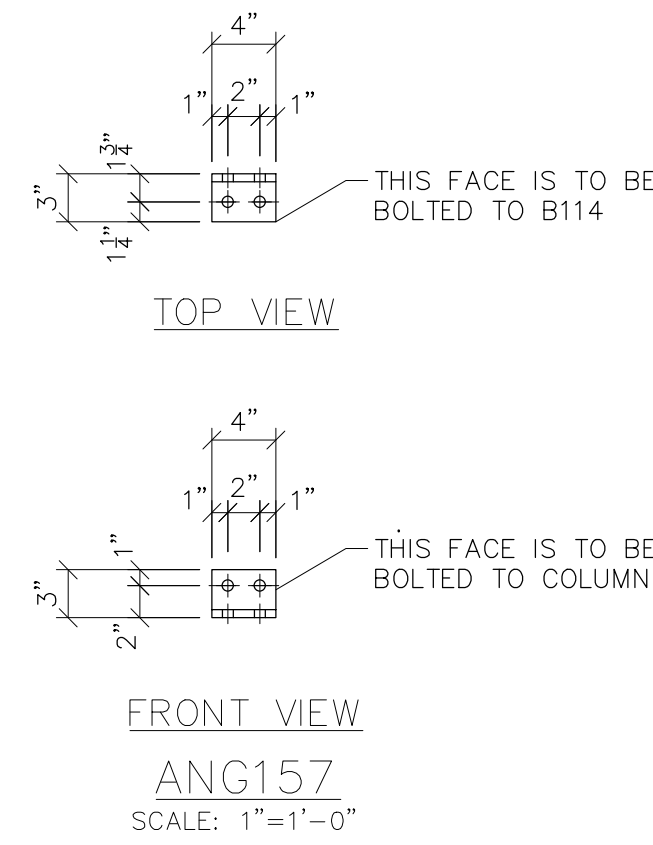
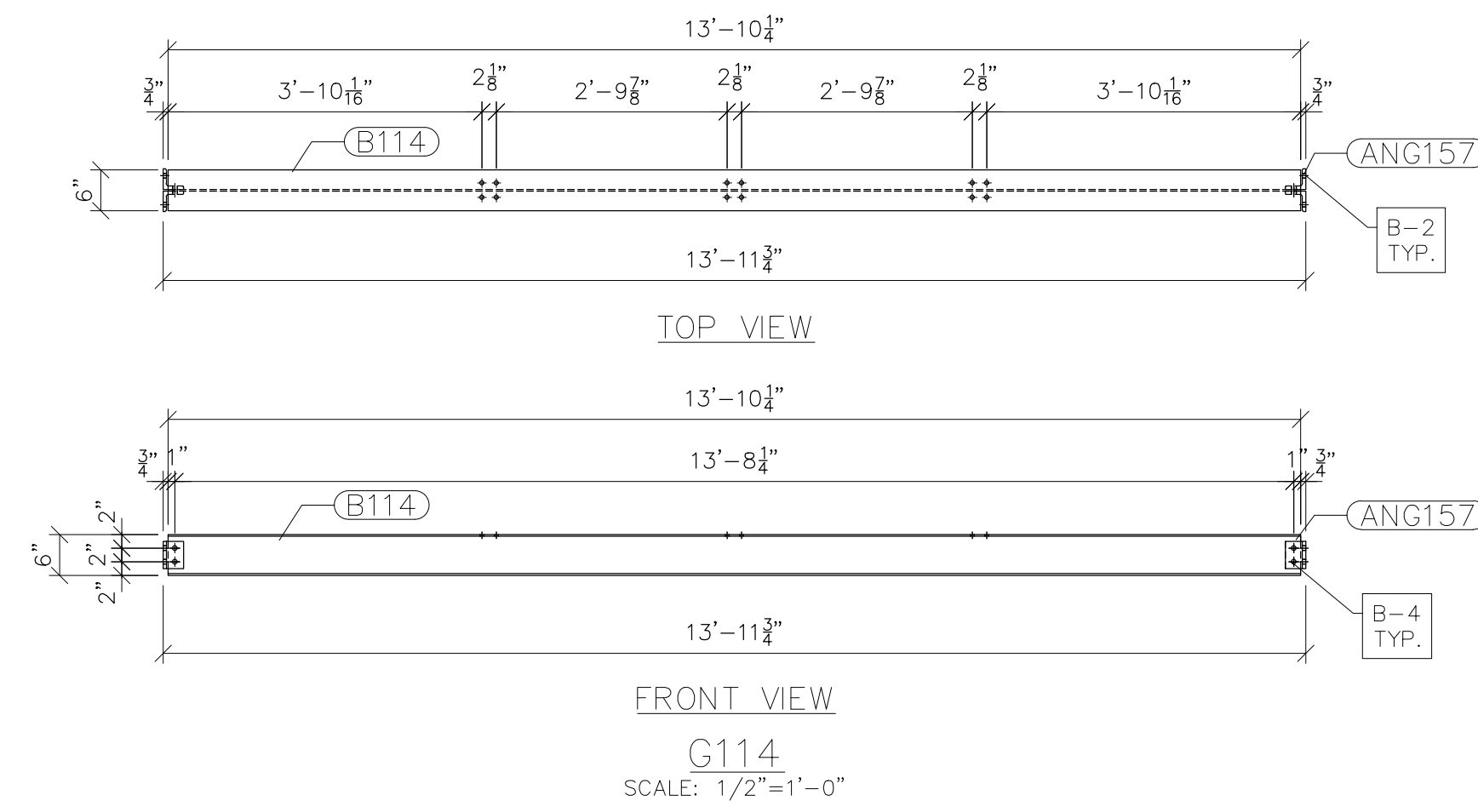

PRELIMINARY -  
DO NOT USE FOR  
CONSTRUCTION

© 05/2023

NO.	ISSUED FOR BID	REVISIONS	ENG.	DATE
A			VK	06/10/2023

PROJECT NAME: CUMBERLAND ROAD  
69 TO 15 X 25 kV  
SUBSTATION

DRAWING TITLE:  
LOW SIDE DETAILS (TRUSSES)

DRAWN BY:	DJD
CHECKED BY:	VK
APPROVED BY:	VK
DATE:	05/10/2023
SCALE:	AS SHOWN
FILE NUMBER:	12510
SHEET:	



- NOTES:
- 1) ASTM 325 ERECTION BOLTS
  - 2) ALL HOT DIP GALVANIZED AFTER FABRICATION (ASTM A123)
  - 3) ALL HOLES 11/16" DIA. FOR 5/8" DIA. BOLTS UNLESS NOTED
  - 4) PIECE MARK STAMPED INTO METAL WITH NOT LESS THAN 3/8" HIGH CHARACTERS BEFORE GALVANIZING
  - 5) ALL WELDING ELECTRODES SHALL BE E7021
  - 6) EDGE DISTANCE 1" UNLESS NOTED

BILL OF MATERIAL				
POS. NO.	QTY	DESC.	LENGTH	WEIGHT
<b>G117</b>	<b>12</b>	<b>FOR ONE G117</b>		
ANG117	2	L2x2x1/4	7 1/8"	3.79
PL148	1	PL 3/8x5	5"	2.66
PL155	1	PL 3/8x5	1'-0"	6.39
			BLACK WEIGHT:	12.84 LBS.
			GALVANIZED WEIGHT:	0.51 LBS.
			TOTAL WEIGHT:	13.35 LBS.
<b>G118</b>	<b>15</b>	<b>FOR ONE G118</b>		
ANG118	2	L2x2x1/4	8 1/4"	4.39
PL148	1	PL 3/8x5	5"	2.66
PL155	1	PL 3/8x5	1'-0"	6.39
			BLACK WEIGHT:	13.44 LBS.
			GALVANIZED WEIGHT:	0.54 LBS.
			TOTAL WEIGHT:	13.98 LBS.
<b>INDIVIDUAL SINGLE PARTS</b>				
ANG116	22	L2x2x3/16	1'-7 9/16"	79.63
P124	12	PIPE1-1/2STD	11'-6 9/16"	314.08
UBT144	24	RB1/2	10 3/8"	11.50
PL190	2	PL 1/4x10	1'-2"	19.88
PL191	2	PL 1/4x4	1'-2"	7.95
			BLACK WEIGHT:	433.04 LBS.
			GALVANIZED WEIGHT:	17.32 LBS.
			TOTAL WEIGHT:	450.36 LBS.

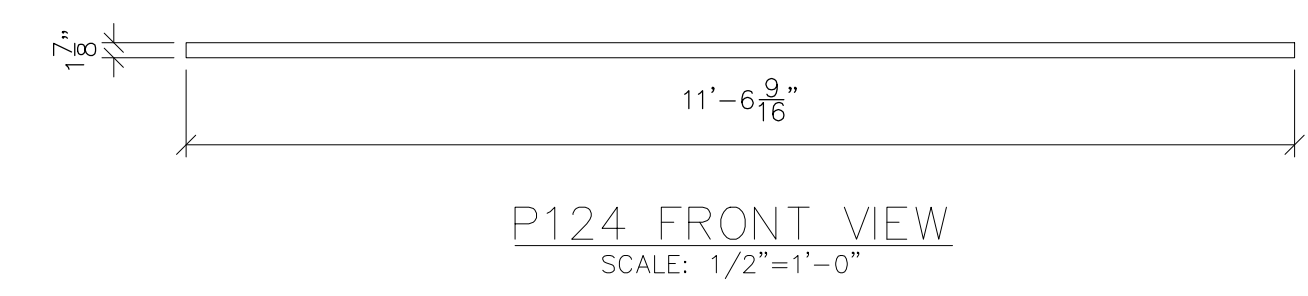
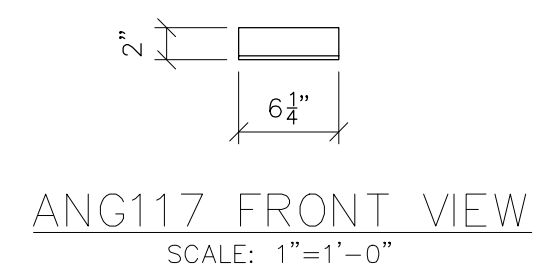
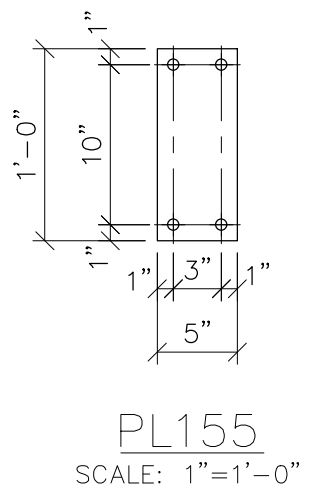
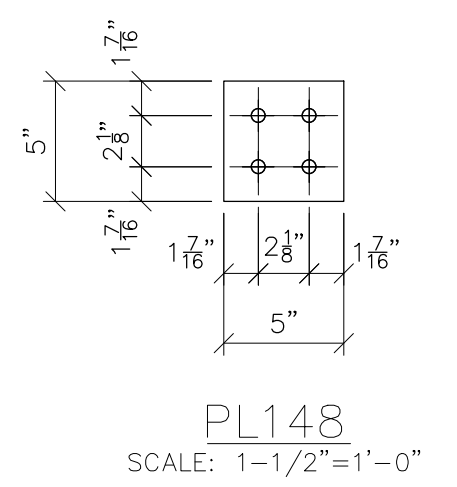
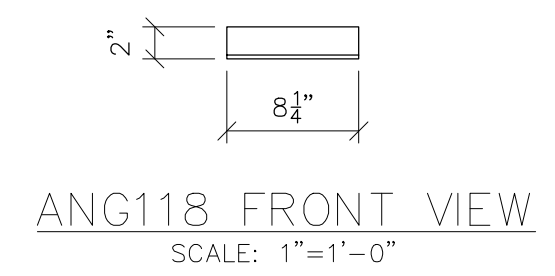
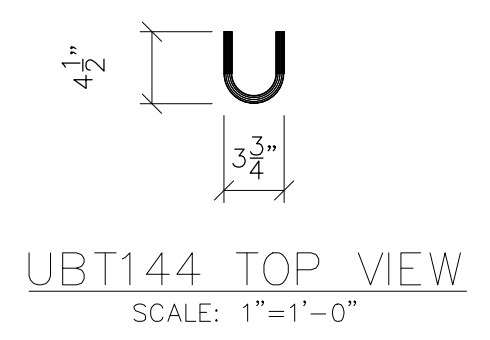
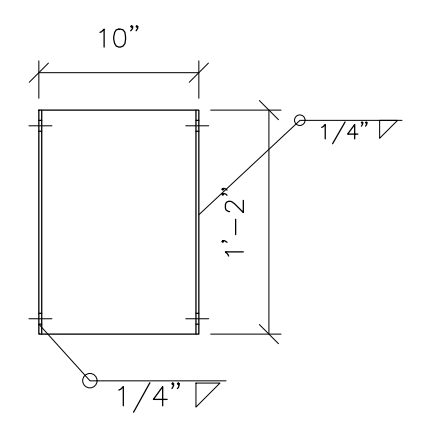
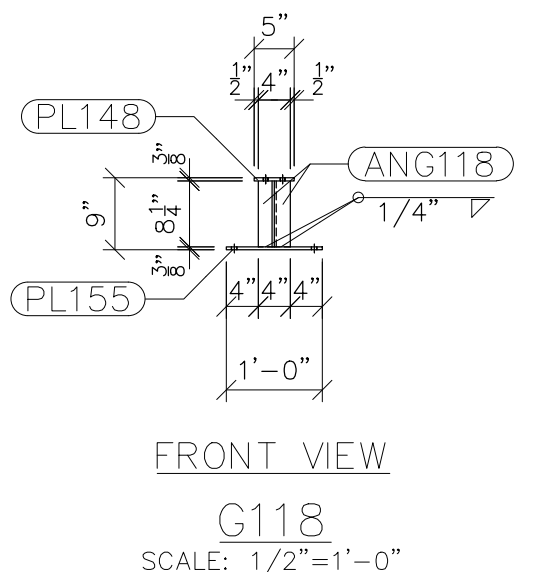
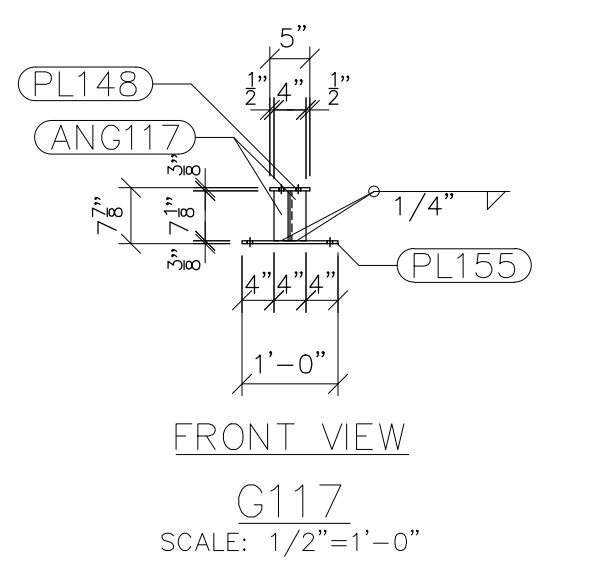
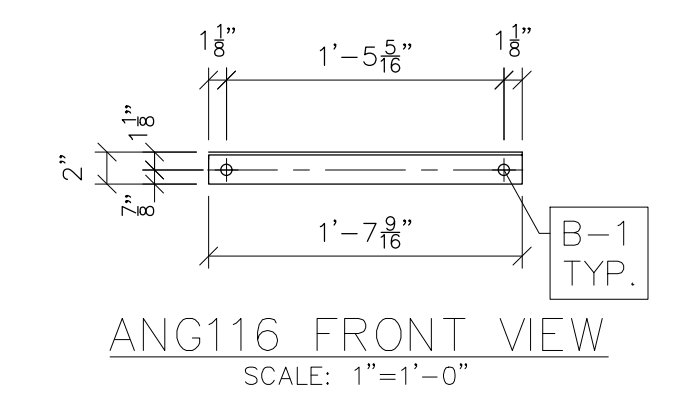
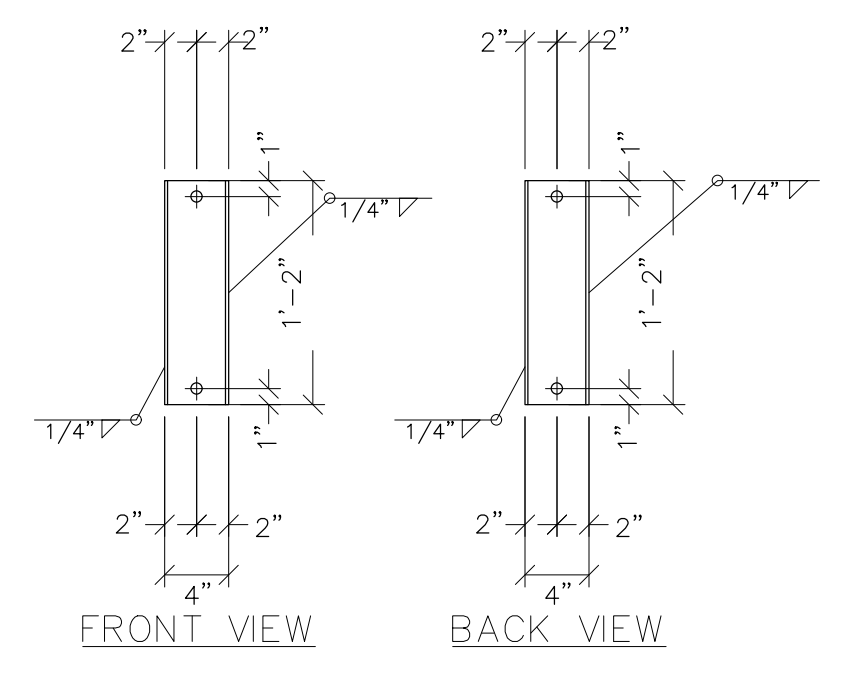
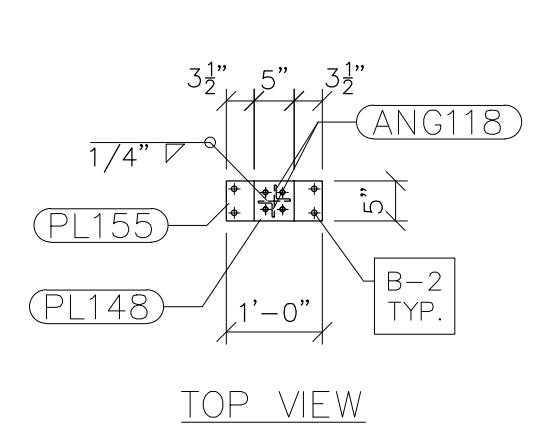
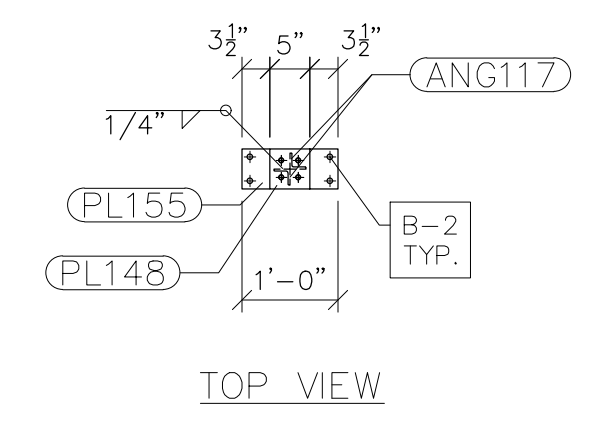

PRELIMINARY - DO NOT USE FOR CONSTRUCTION

© 05/2023

NO.	REVISIONS	ENG.	DATE
A	ISSUED FOR BID	VK	06/10/2023

PROJECT NAME:	CUMBERLAND ROAD 69 TO 15 X 25 kV SUBSTATION
DRAWING TITLE:	LOW SIDE DETAILS (TRUSSES)
DRAWN BY:	DJD
CHECKED BY:	VK
APPROVED BY:	VK
DATE:	05/10/2023
SCALE:	AS SHOWN
FILE NUMBER:	12510
SHEET:	

- NOTES:  
 1) ASTM 325 ERECTION BOLTS  
 2) ALL HOT DIP GALVANIZED AFTER FABRICATION (ASTM A123)  
 3) ALL HOLES 11/16" DIA. FOR 5/8" DIA. BOLTS UNLESS NOTED  
 4) PIECE MARK STAMPED INTO METAL WITH NOT LESS THAN 3/8" HIGH CHARACTERS BEFORE GALVANIZING  
 5) ALL WELDING ELECTRODES SHALL BE E7021  
 6) EDGE DISTANCE 1" UNLESS NOTED

BILL OF MATERIAL				
POS. NO.	QTY	DESC.	LENGTH	WEIGHT
<b>G120</b>	<b>2</b>	<b>FOR ONE GROUP G120</b>		
ANG157	4	L3x3x1/2	4"	12.53
B120	1	W6x15	15'-10 1/4"	237.81
BLACK WEIGHT:				250.34 LBS.
GALVANIZED WEIGHT:				10.01 LBS.
TOTAL WEIGHT:				260.35 LBS.

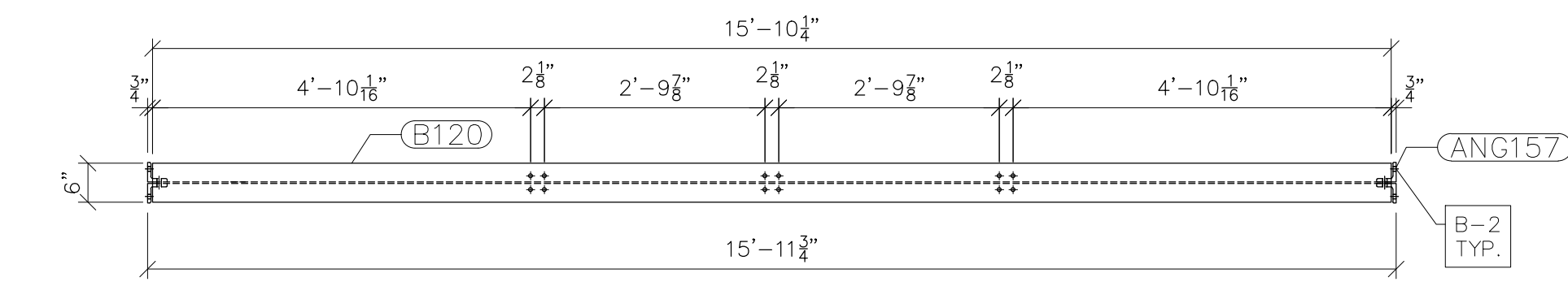

TOP VIEW

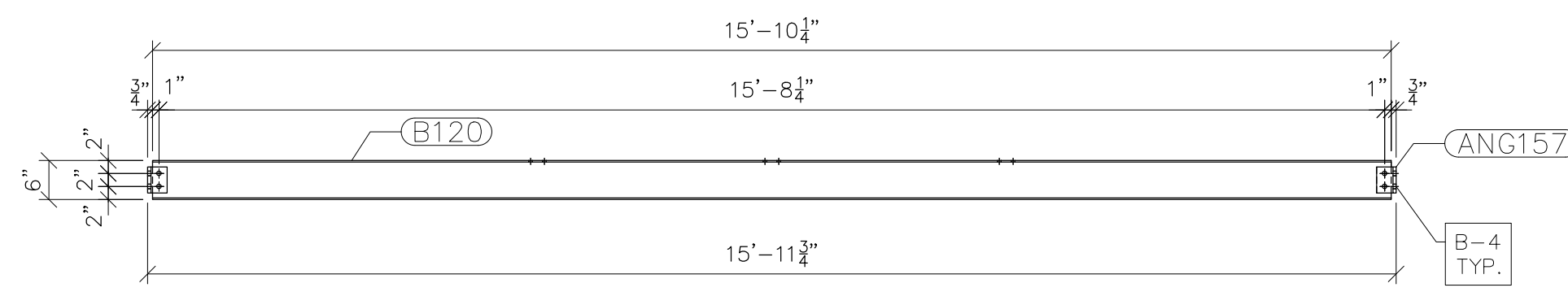

FRONT VIEW

G120  
SCALE: 1/2"=1'-0"

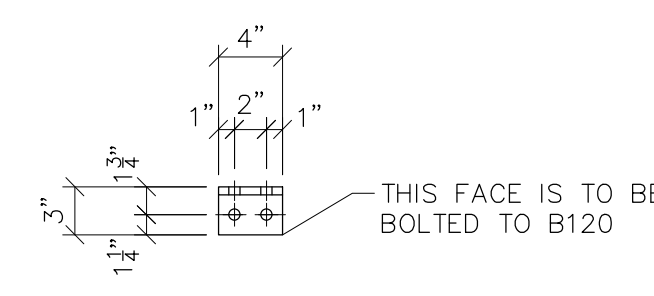

TOP VIEW

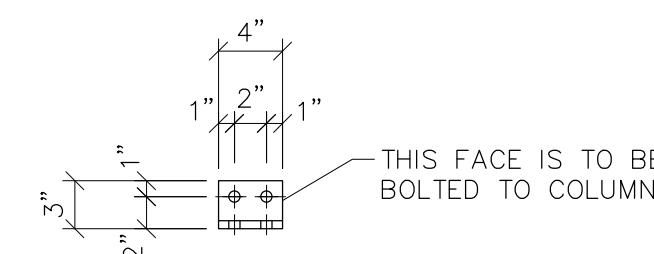

FRONT VIEW

ANG157  
SCALE: 1"=1'-0"



PRELIMINARY -  
DO NOT USE FOR  
CONSTRUCTION

© 05/2023

NO.	ISSUED FOR BID	REVISIONS	ENG.	DATE
A			VK	06/10/2023

PROJECT NAME: CUMBERLAND ROAD  
69 TO 15 X 25 kV  
SUBSTATION

DRAWING TITLE:  
LOW SIDE DETAILS (TRUSSES)

DRAWN BY:	DJD
CHECKED BY:	VK
APPROVED BY:	VK
DATE:	05/10/2023
SCALE:	AS SHOWN
FILE NUMBER:	12510
SHEET:	

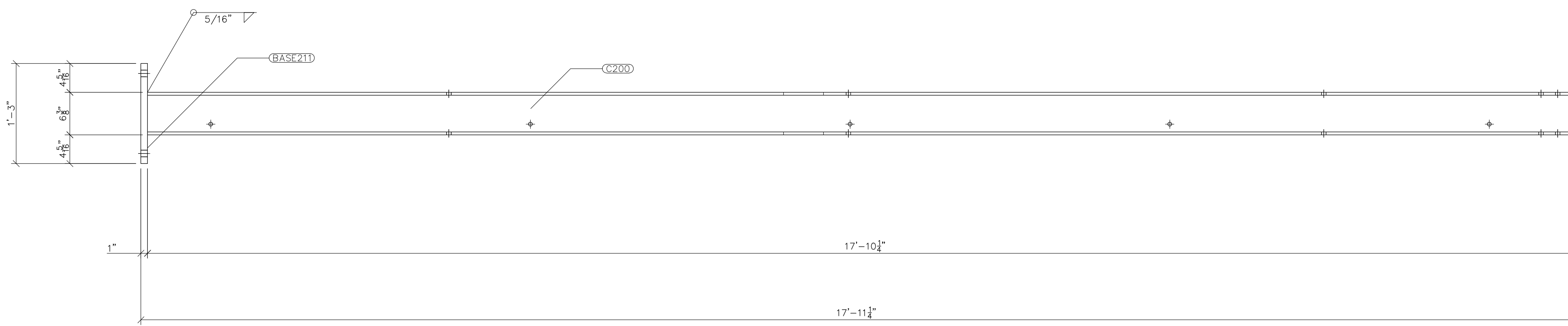

G200 FRONT VIEW  
SCALE: 1"=1'-0"

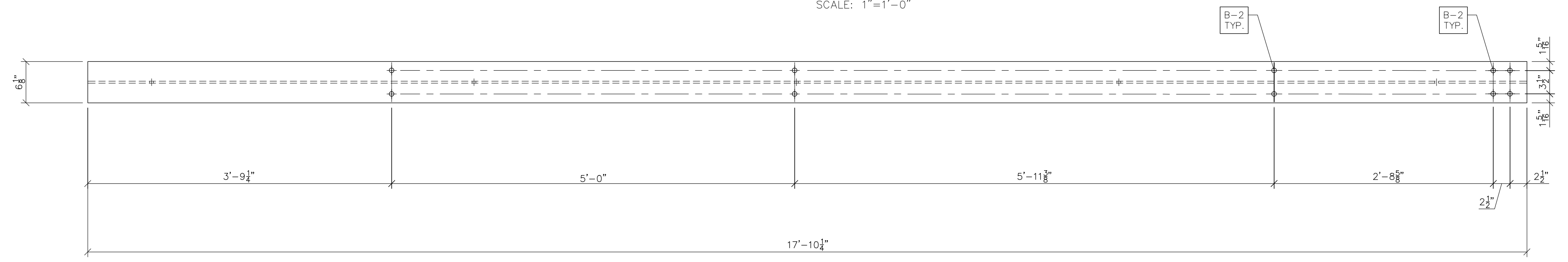

TOP VIEW

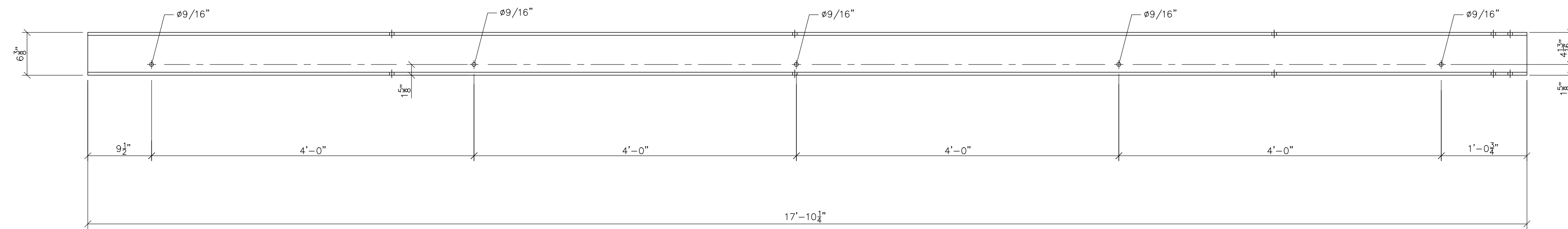

FRONT VIEW

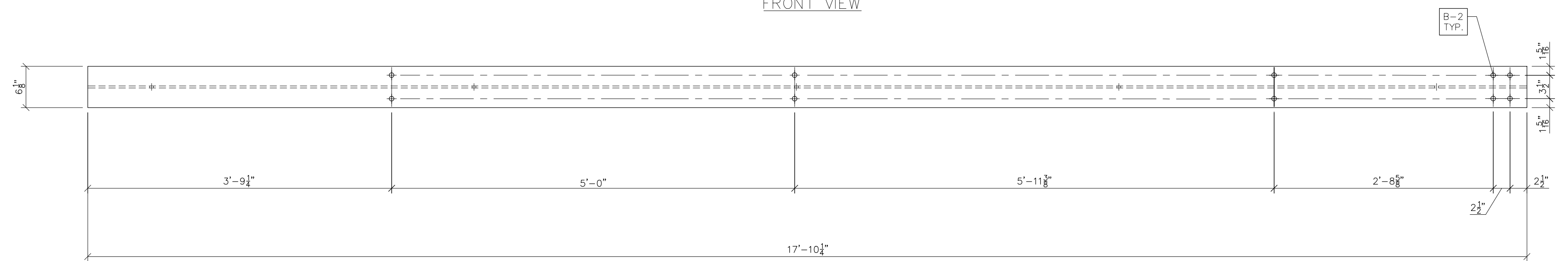

BOTTOM VIEW

C200  
SCALE: 1"=1'-0"

- NOTES:
- 1) ASTM 325 ERECTION BOLTS
  - 2) ALL HOT DIP GALVANIZED AFTER FABRICATION (ASTM A123)
  - 3) ALL HOLES 1 1/16" DIA. FOR 5/8" DIA. BOLTS UNLESS NOTED
  - 4) PIECE MARK STAMPED INTO METAL WITH NOT LESS THAN 3/8" HIGH CHARACTERS BEFORE GALVANIZING
  - 5) ALL WELDING ELECTRODES SHALL BE E7021
  - 6) EDGE DISTANCE 1" UNLESS NOTED

BILL OF MATERIAL				
POS. NO.	QTY	DESC	LENGTH	WEIGHT
G200	6	FOR ONE GROUP G200:		
BASE211	1	PL 1"x1'-3"	1'-3"	63.80
C200	1	W6x25	17'-10 1/4"	446.35
BLACK WEIGHT:				510.15 LBS.
GALVANIZED WEIGHT:				20.41 LBS.
TOTAL WEIGHT:				530.56 LBS.

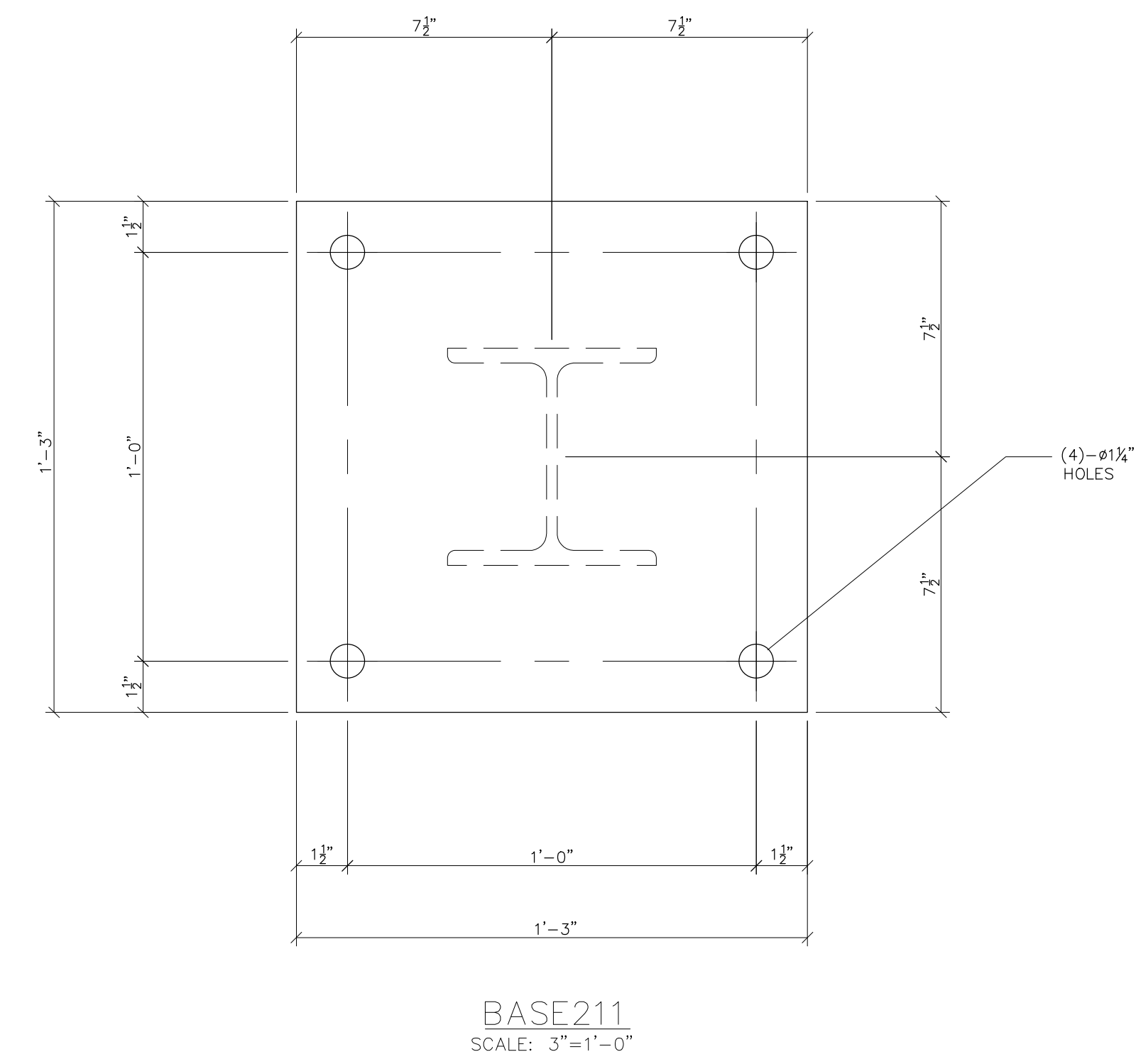

PRELIMINARY -  
DO NOT USE FOR  
CONSTRUCTION

© 05/2023

NO.	ISSUED FOR BID	REVISIONS	ENG.	DATE
A			VK	06/10/2023

PROJECT NAME: CUMBERLAND ROAD  
69 TO 15 X 25 kV  
SUBSTATION

DRAWING TITLE: URD STAND DETAILS

DRAWN BY:	DJD
CHECKED BY:	VK
APPROVED BY:	VK
DATE:	05/10/2023
SCALE:	AS SHOWN
FILE NUMBER:	12510
SHEET:	

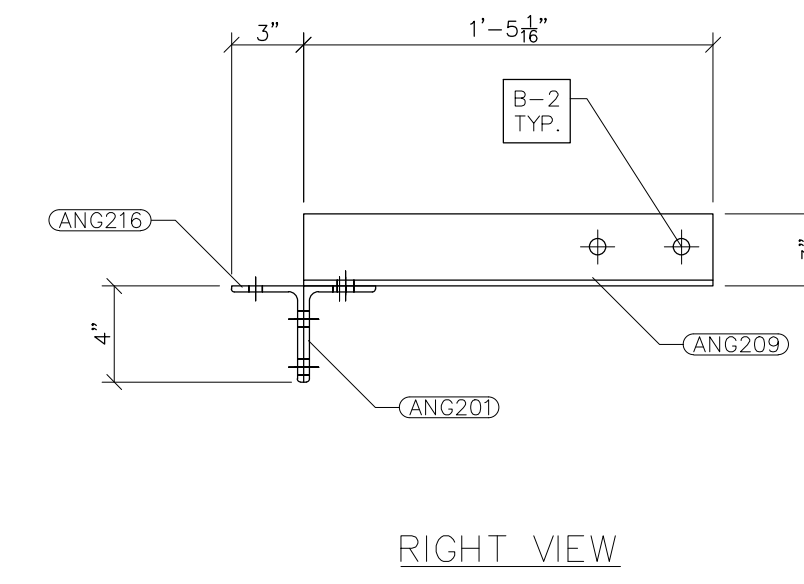
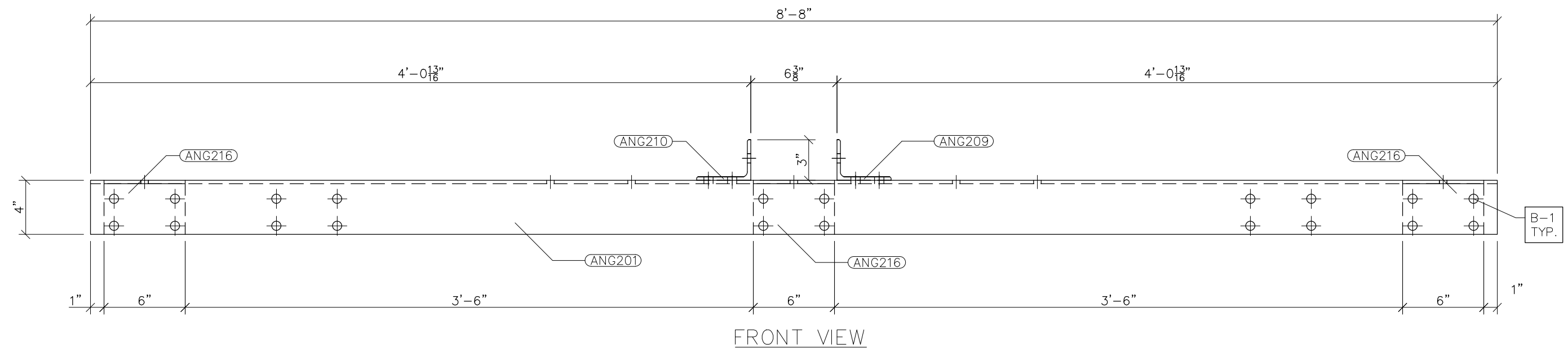

- NOTES:
- 1) ASTM 325 ERECTION BOLTS
  - 2) ALL HOT DIP GALVANIZED AFTER FABRICATION (ASTM A123)
  - 3) ALL HOLES 1 1/16" DIA. FOR 5/8" DIA. BOLTS UNLESS NOTED
  - 4) PIECE MARK STAMPED INTO METAL WITH NOT LESS THAN 3/8" HIGH CHARACTERS BEFORE GALVANIZING
  - 5) ALL WELDING ELECTRODES SHALL BE E7021
  - 6) EDGE DISTANCE 1" UNLESS NOTED

BILL OF MATERIAL				
POS. NO.	QTY	DESC.	LENGTH	WEIGHT
<b>G201</b>	<b>6</b>	<b>FOR ONE GROUP G201:</b>		
ANG201	1	L4x3x1/4	8'-8"	50.27
ANG209	1	L4x3x1/4	1'-5 1/16"	8.25
ANG210	1	L4x3x1/4	1'-5 1/16"	8.25
ANG216	3	L4x3x1/4	6"	8.70
BLACK WEIGHT:				75.47 LBS.
GALVANIZED WEIGHT:				3.01 LBS.
TOTAL WEIGHT:				78.99 LBS.

G201  
SCALE: 1-1/2"=1'-0"

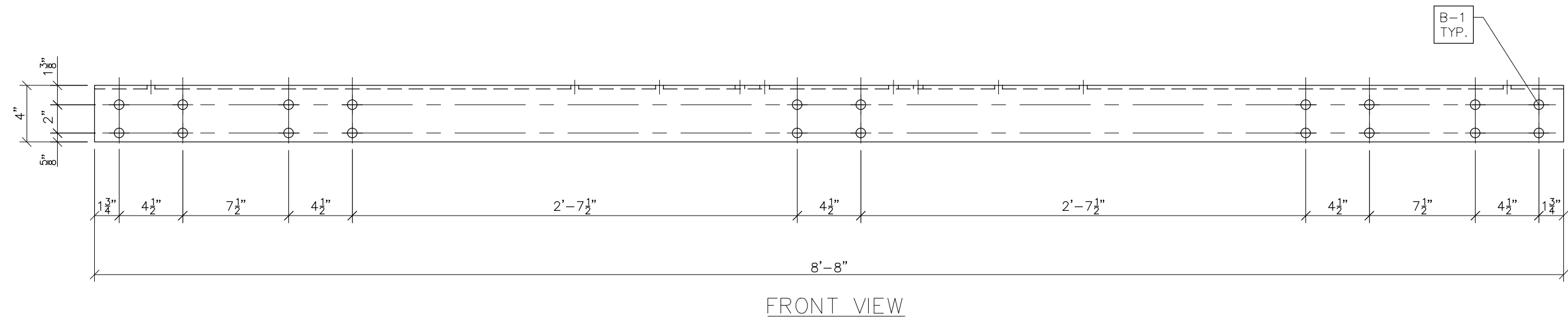
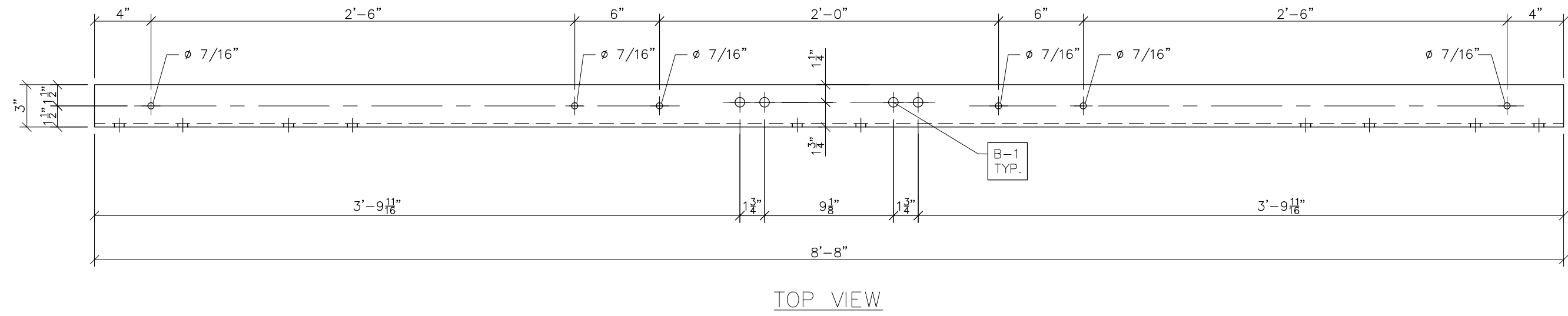

ANG201  
SCALE: 1-1/2"=1'-0"

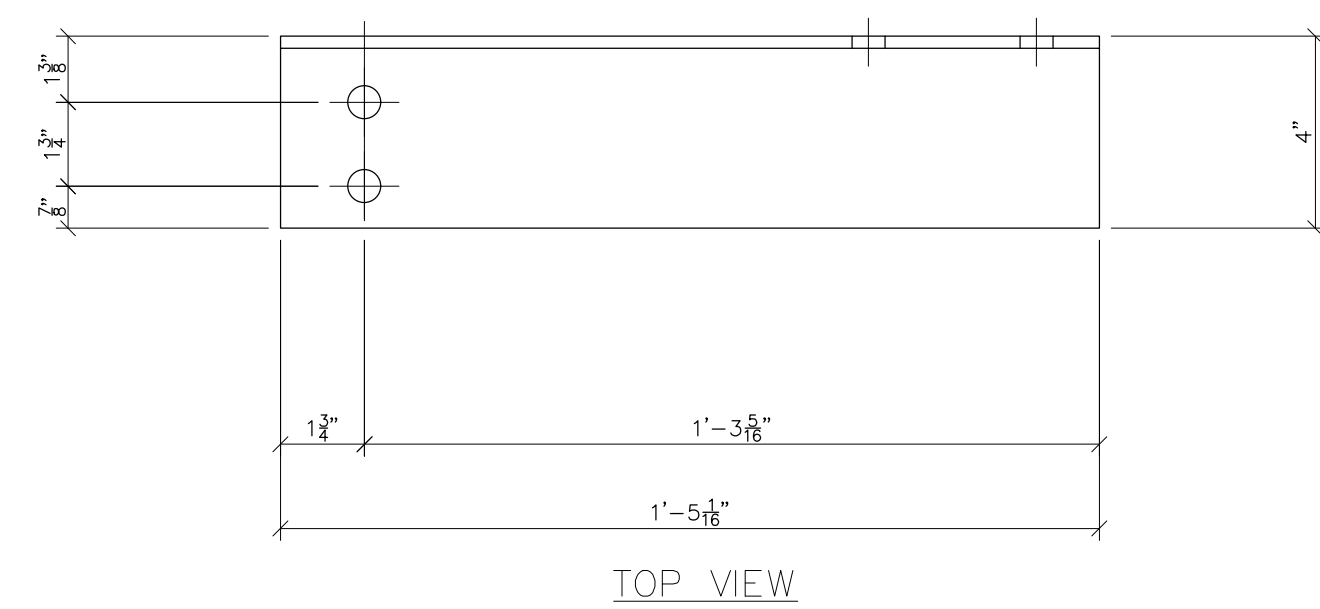
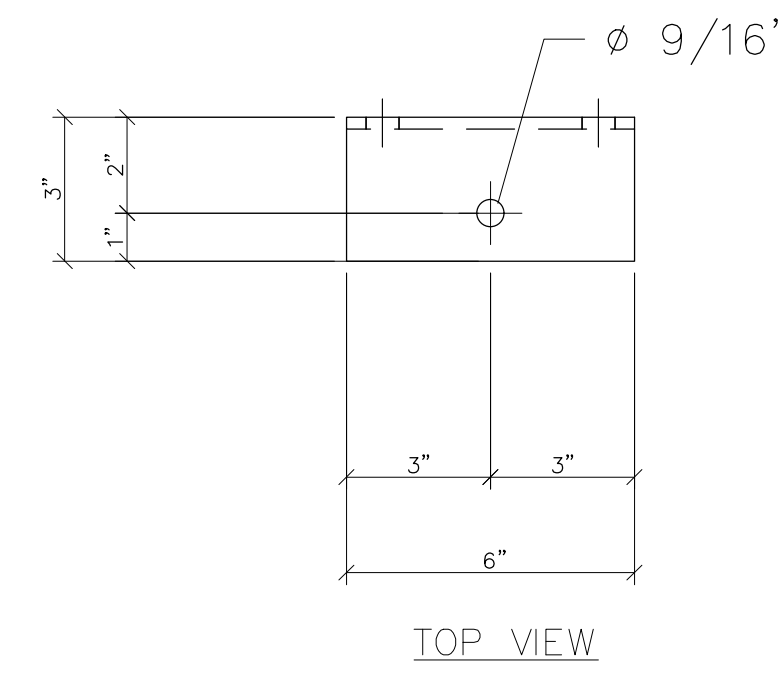
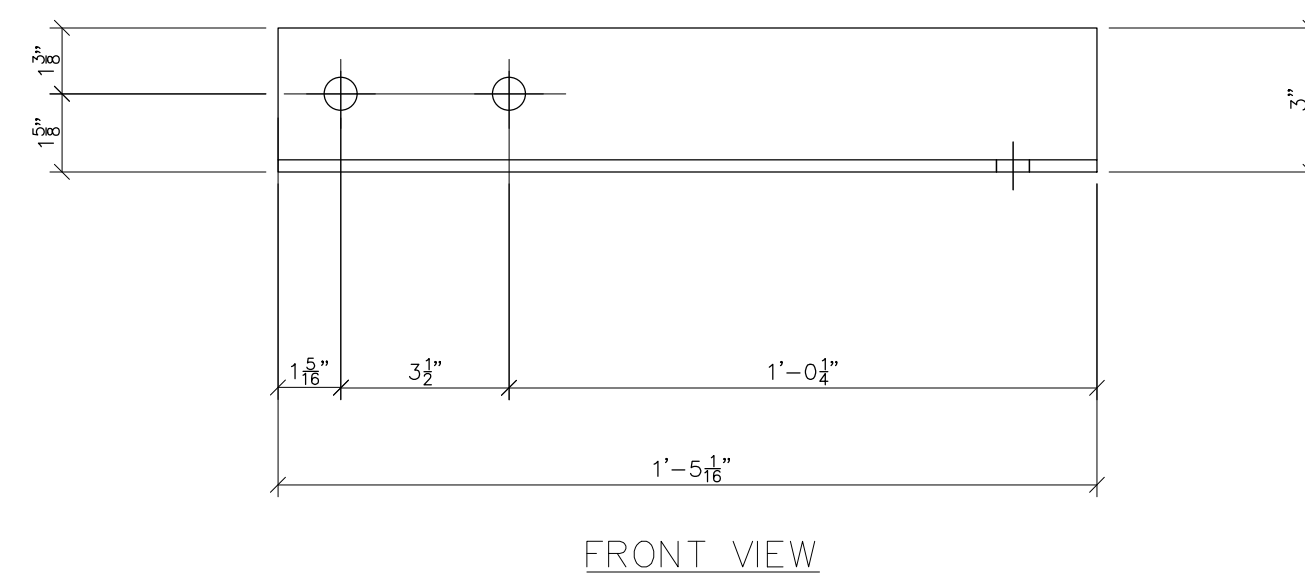
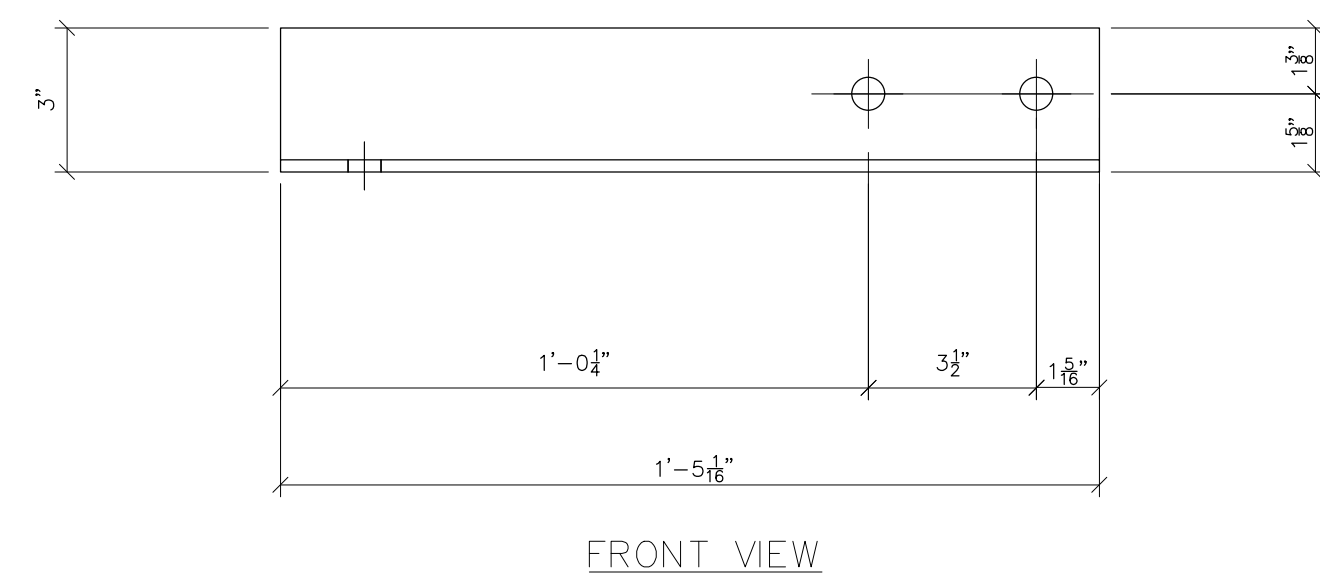

ANG209  
SCALE: 3"=1'-0"

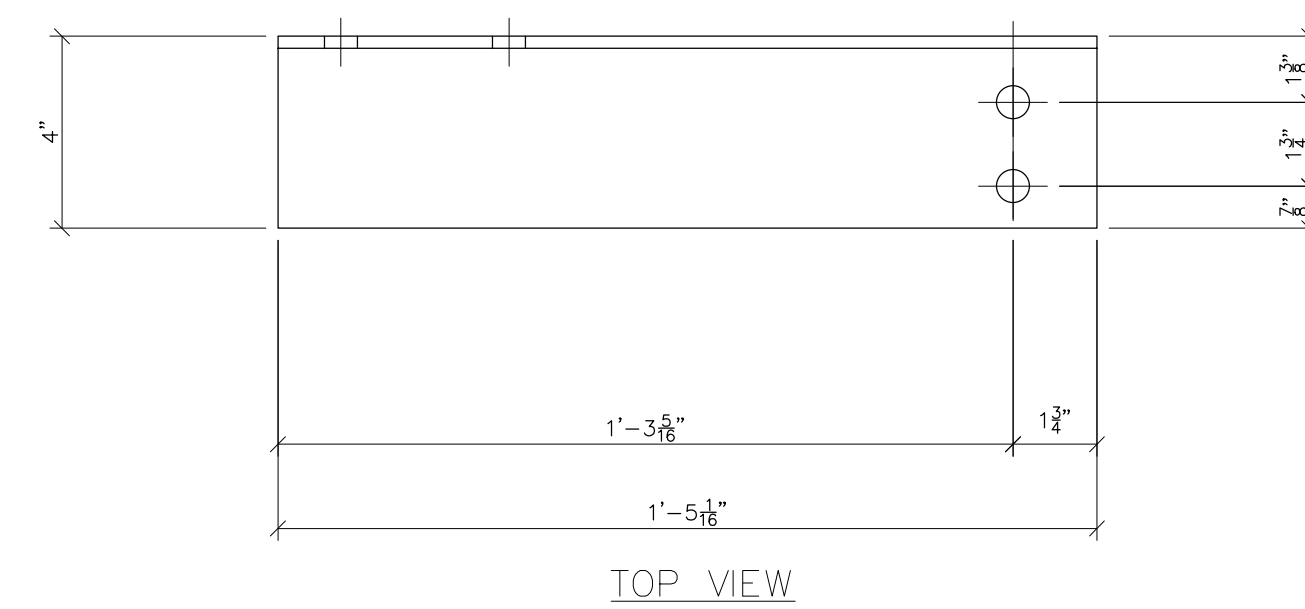

ANG210  
SCALE: 3"=1'-0"

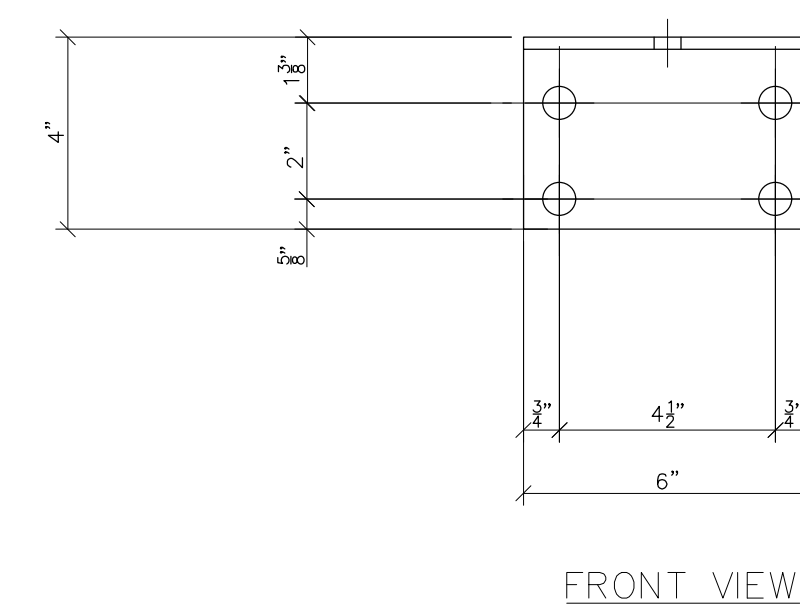

ANG216  
SCALE: 3"=1'-0"



PRELIMINARY -  
DO NOT USE FOR  
CONSTRUCTION

© 05/2023

NO.	ISSUED FOR BID	REVISIONS	ENG.	DATE
A			VK	06/10/2023

PROJECT NAME: CUMBERLAND ROAD  
69 TO 15 X 25 kV  
SUBSTATION  
DRAWING TITLE: URD STAND DETAILS

DRAWN BY:	DJD
CHECKED BY:	VK
APPROVED BY:	VK
DATE:	05/10/2023
SCALE:	AS SHOWN
FILE NUMBER:	12510
SHEET:	

URD-2

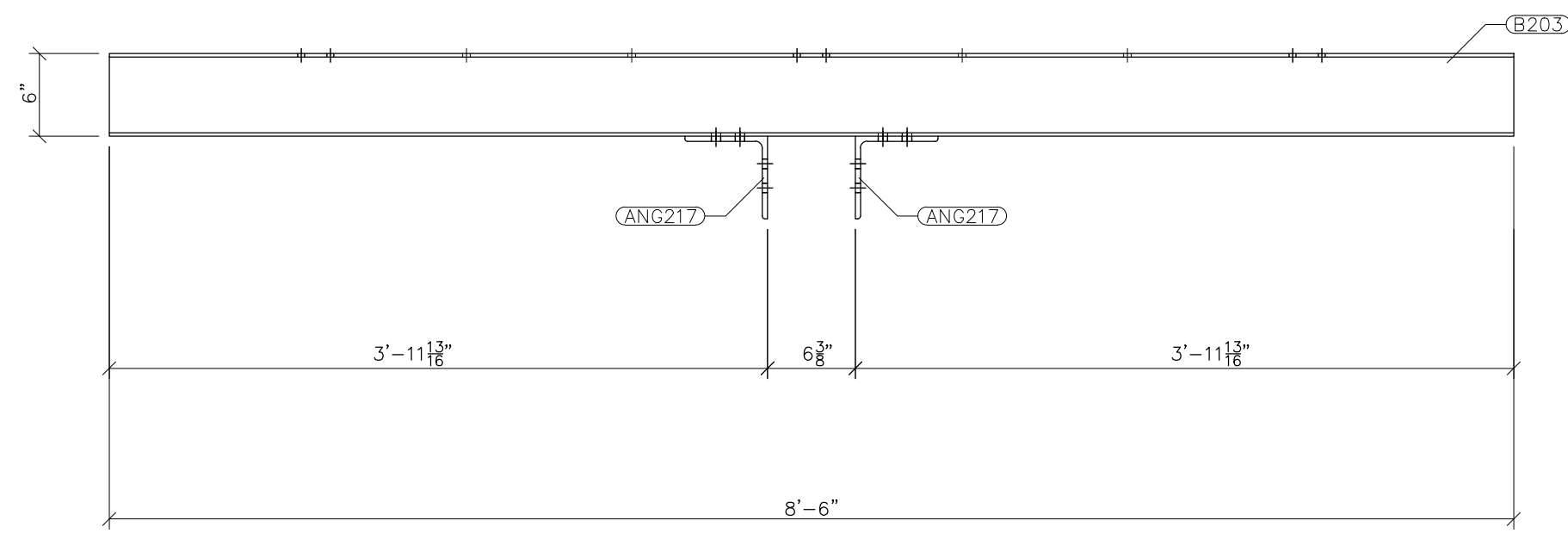

FRONT VIEW

G203  
SCALE: 1"=1'-0"

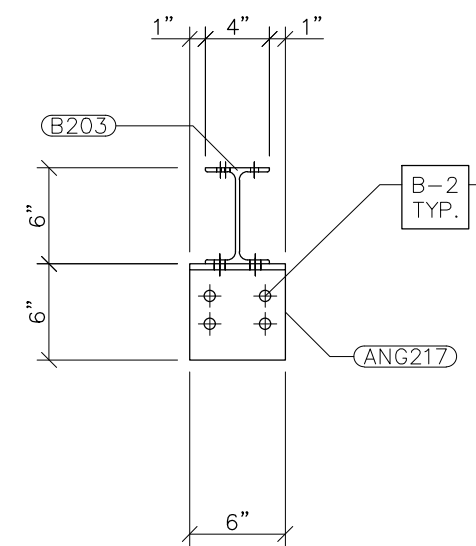

RIGHT VIEW

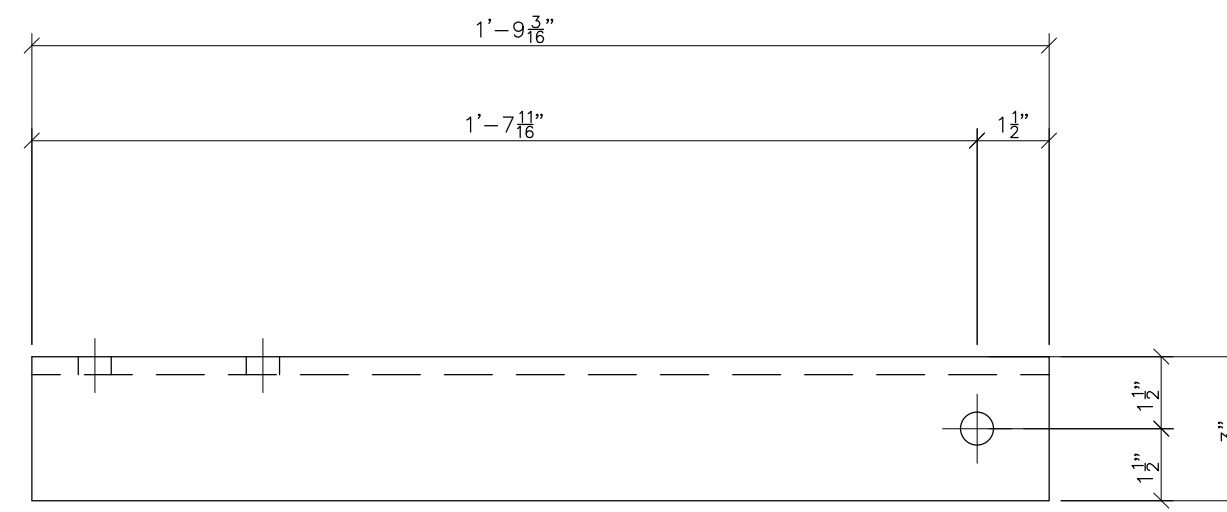

TOP VIEW

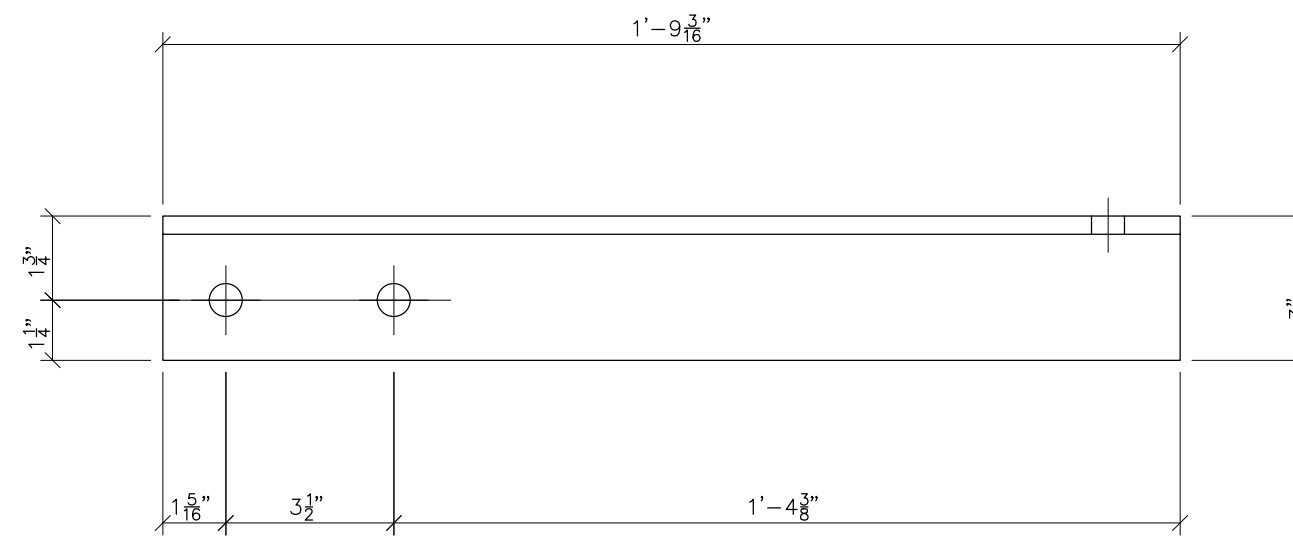

FRONT VIEW

G204  
SCALE: 3"=1'-0"

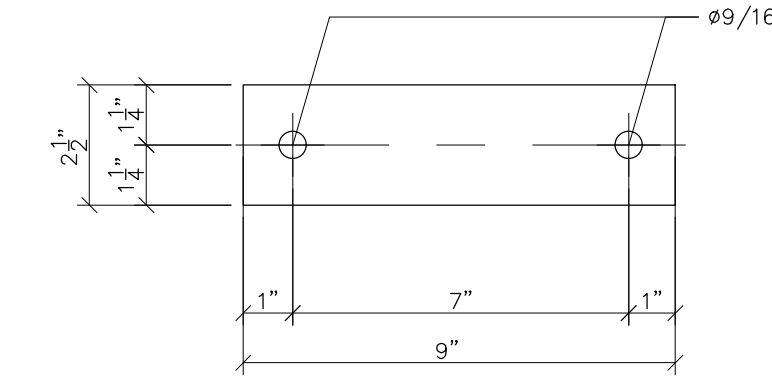

PL214  
SCALE: N.T.S.

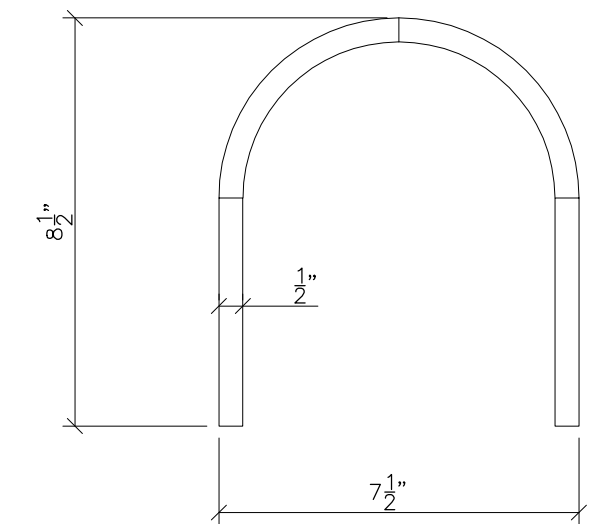

UBT208  
SCALE: N.T.S.

- NOTES:
- 1) ASTM 325 ERECTION BOLTS
  - 2) ALL HOT DIP GALVANIZED AFTER FABRICATION (ASTM A123)
  - 3) ALL HOLES 11/16" DIA. FOR 5/8" DIA. BOLTS UNLESS NOTED
  - 4) PIECE MARK STAMPED INTO METAL WITH NOT LESS THAN 3/8" HIGH CHARACTERS BEFORE GALVANIZING
  - 5) ALL WELDING ELECTRODES SHALL BE E7021
  - 6) EDGE DISTANCE 1" UNLESS NOTED

BILL OF MATERIAL				
POS. NO.	QTY	DESC.	LENGTH	WEIGHT
<b>G203 FOR ONE GROUP G203:</b>				
ANG217	2	L6x6x3/8	6"	14.84
B203	1	W6x12	8'-6"	102.00
			BLACK WEIGHT:	116.84 LBS.
			GALVANIZED WEIGHT:	4.67 LBS.
			TOTAL WEIGHT:	121.51 LBS.
<b>G204 FOR ONE GROUP G204:</b>				
ANG204	1	L3x3x3/8	1'-9 3/16"	25.36
ANG206	1	L3x3x3/8	1'-9 3/16"	25.36
ANG213	1	L3x3x1/4	1'-0 3/8"	5.06
PL214	1	FB1/4x2-1/2	9"	1.57
UBT208	1	ø1/2" U-Bolt	1'-8 1/2"	1.14
			BLACK WEIGHT:	58.49 LBS.
			GALVANIZED WEIGHT:	2.34 LBS.
			TOTAL WEIGHT:	60.83 LBS.

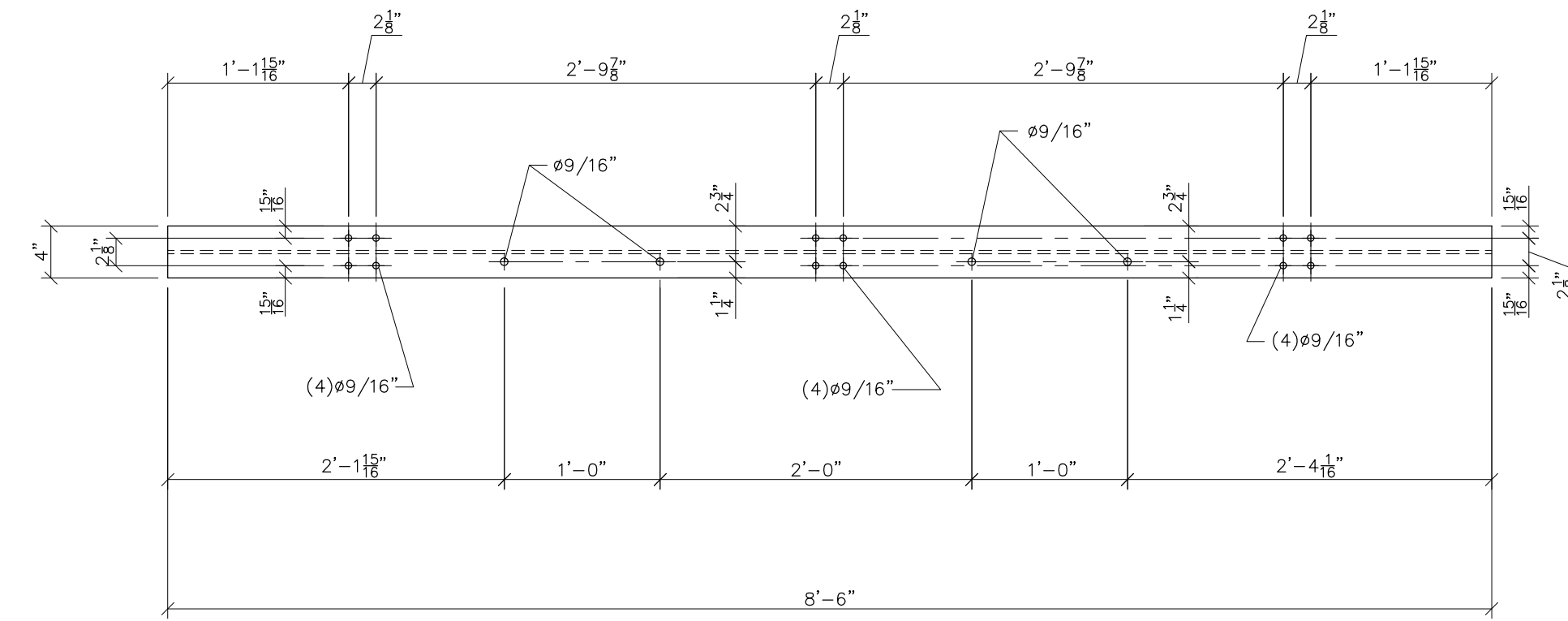

TOP VIEW

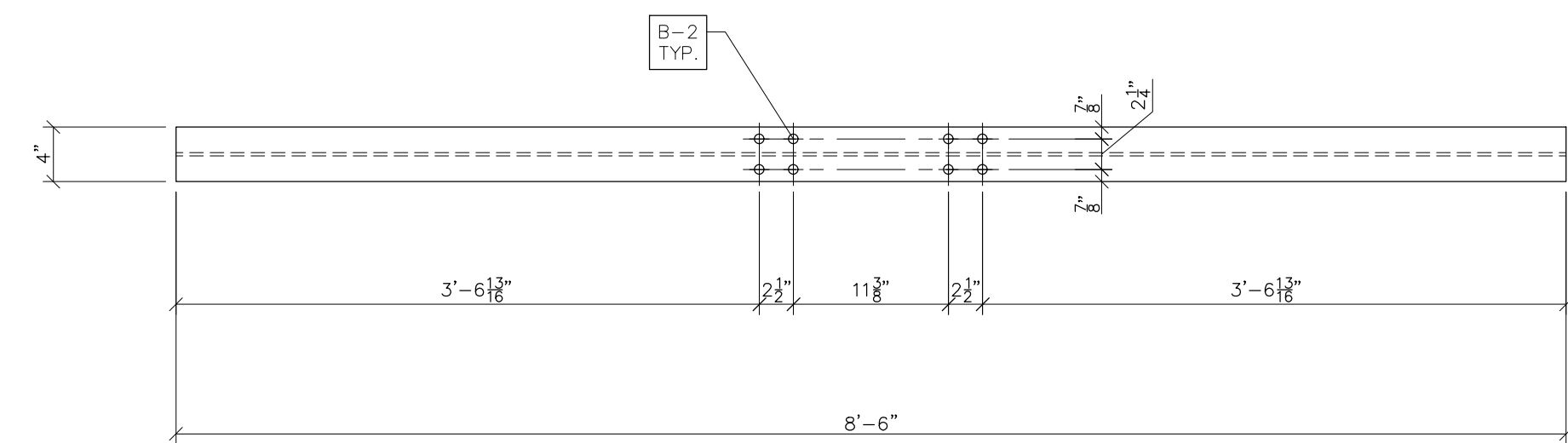

BOTTOM VIEW

B203  
SCALE: 1"=1'-0"

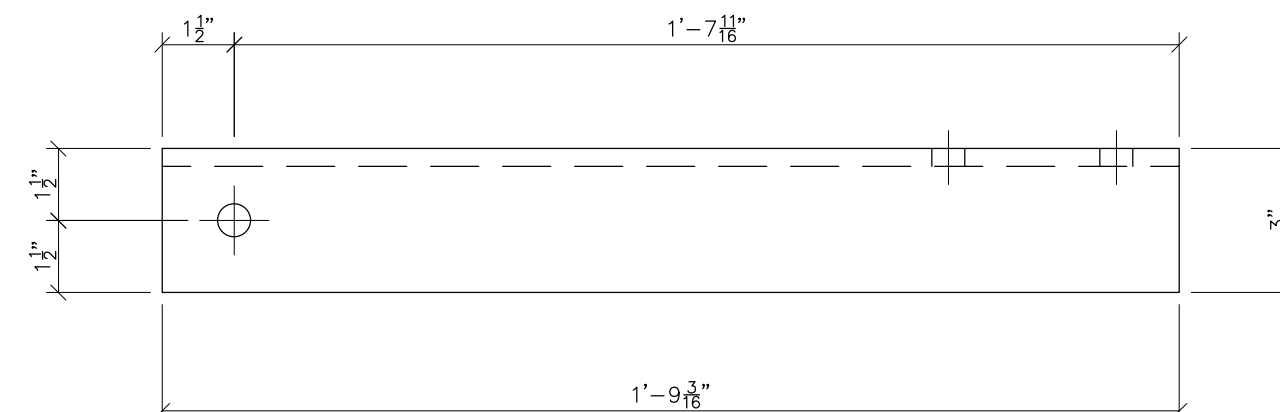

TOP VIEW

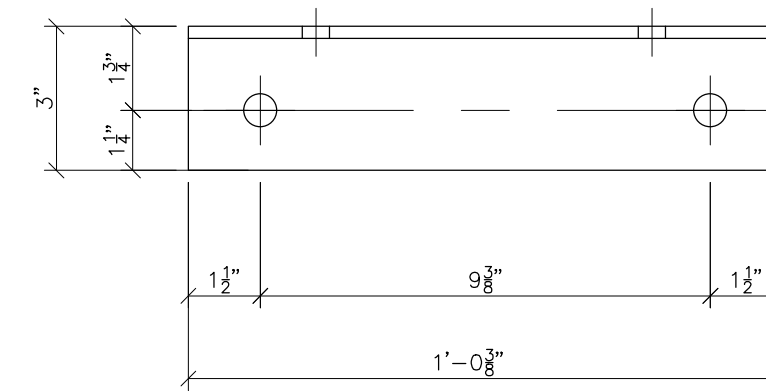

TOP VIEW

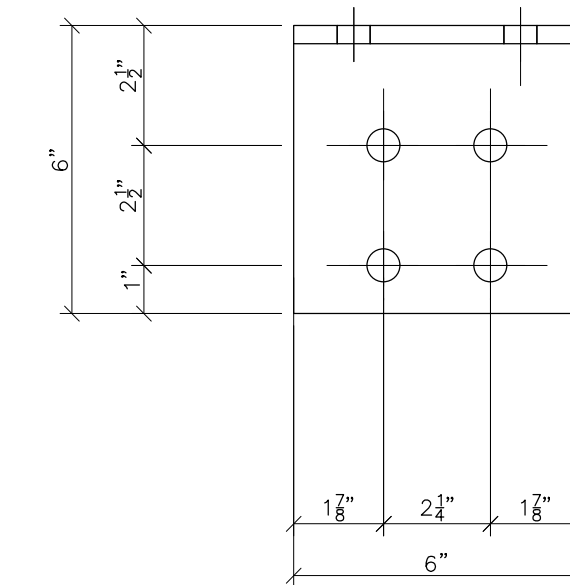

TOP VIEW

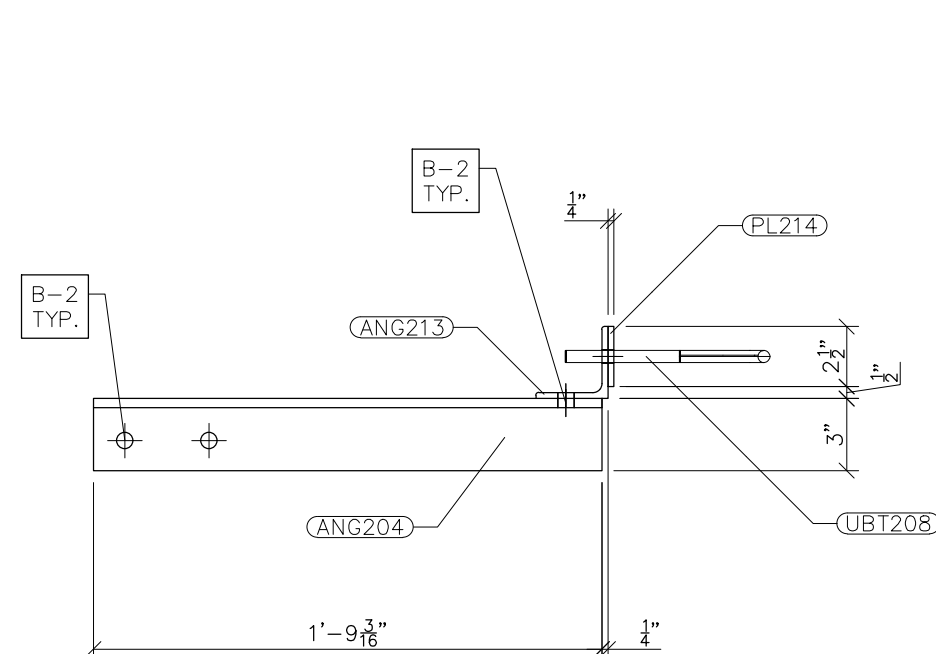

FRONT VIEW

G204  
SCALE: 1-1/2"=1'-0"

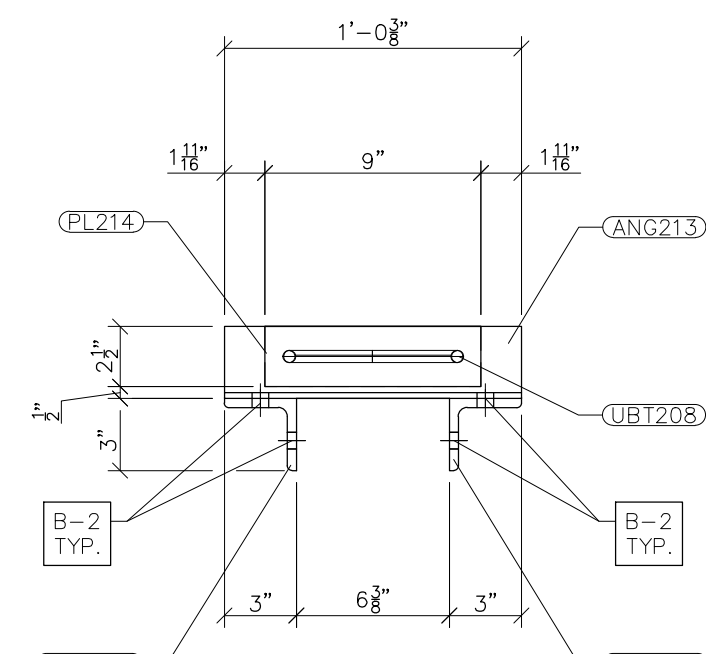

RIGHT VIEW

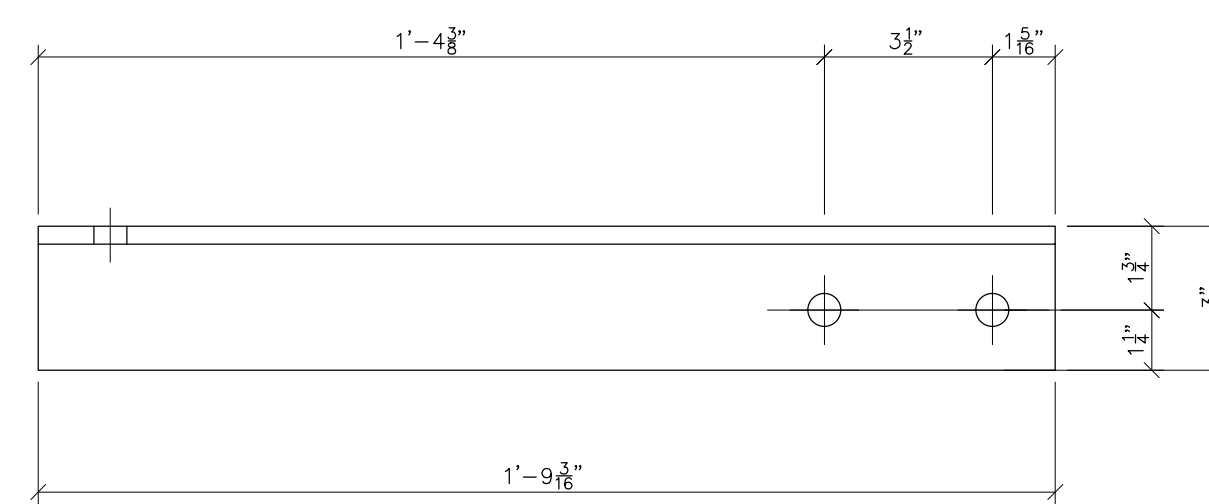

FRONT VIEW

ANG206  
SCALE: 3"=1'-0"

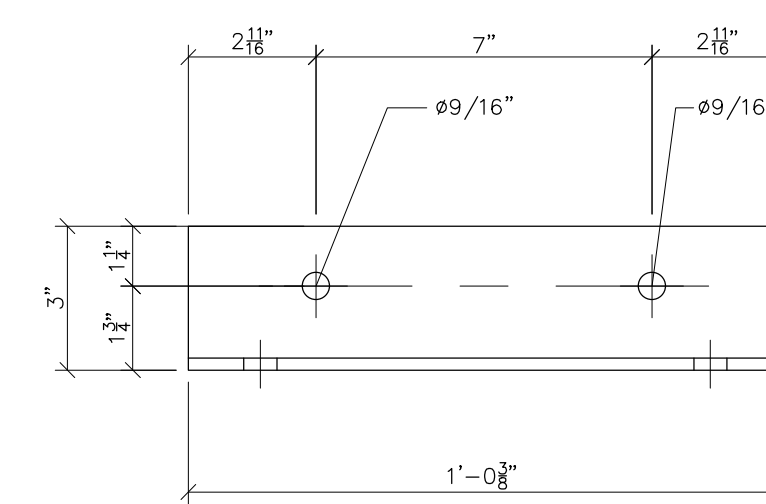

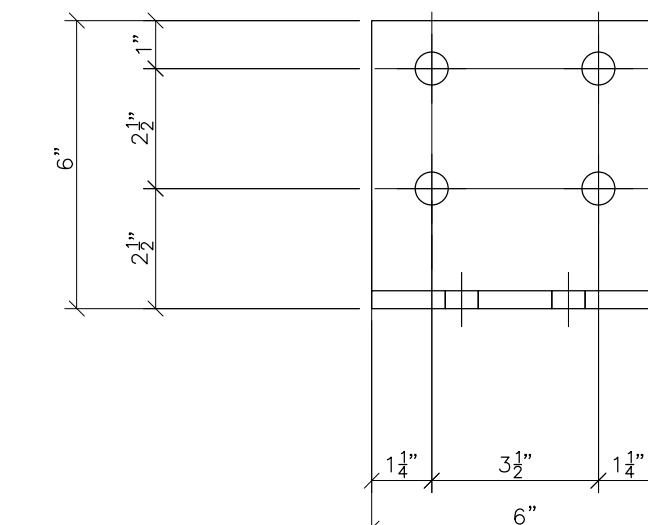

FRONT VIEW

ANG206  
SCALE: 3"=1'-0"



FRONT VIEW

ANG217  
SCALE: 3"=1'-0"

PRELIMINARY - DO NOT USE FOR CONSTRUCTION

NO.	REVISIONS	ENG.	DATE
A	ISSUED FOR BID	VK	06/10/2023

© 05/2023

PROJECT NAME: CUMBERLAND ROAD 69 TO 15 X 25 kV SUBSTATION

DRAWING TITLE: URD STAND DETAILS

DRWN BY: DJD

CHECKED BY: VK

APPROVED BY: VK

DATE: 05/10/2023

SCALE: AS SHOWN

FILE NUMBER: 12510

SHEET: URD-3

- NOTES:
- 1) ASTM 325 ERECTION BOLTS
  - 2) ALL HOT DIP GALVANIZED AFTER FABRICATION (ASTM A123)
  - 3) ALL HOLES 11/16" DIA. FOR 5/8" DIA. BOLTS UNLESS NOTED
  - 4) PIECE MARK STAMPED INTO METAL WITH NOT LESS THAN 3/8" HIGH CHARACTERS BEFORE GALVANIZING
  - 5) ALL WELDING ELECTRODES SHALL BE E7021
  - 6) EDGE DISTANCE 1" UNLESS NOTED

BILL OF MATERIAL				
POS. NO.	QTY	DESC.	LENGTH	WEIGHT
<b>G311</b>	<b>1</b>	<b>FOR ONE GROUP G311:</b>		
PL324	3	PL 1/2"x3"	1'-5"	21.69
PL350	2	PL 1/2"x2'-0"	2'-3 5/8"	163.69
PL354	3	PL 1/2"x10 1/4"	1'-4"	69.90
ST311	1	HSS10x10x1/4	27'-3"	888.28
GR1	2	STD GRA 9 3/8"	9 3/8"	9.00
			BLACK WEIGHT:	1152.56 LBS.
			GALVANIZED WEIGHT:	46.10 LBS.
			TOTAL WEIGHT:	1198.66 LBS.

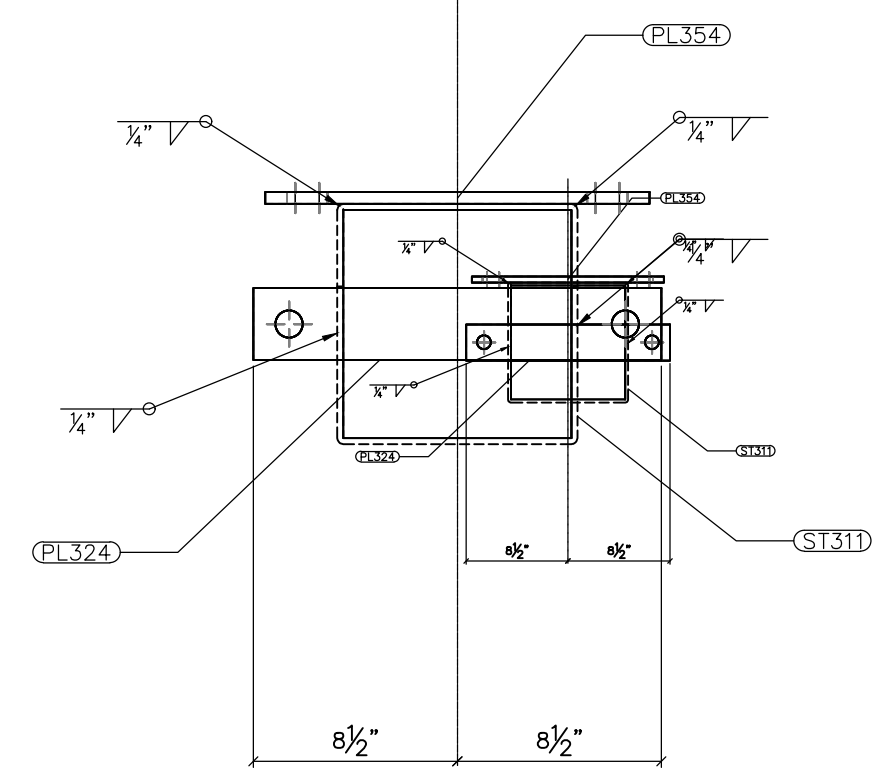
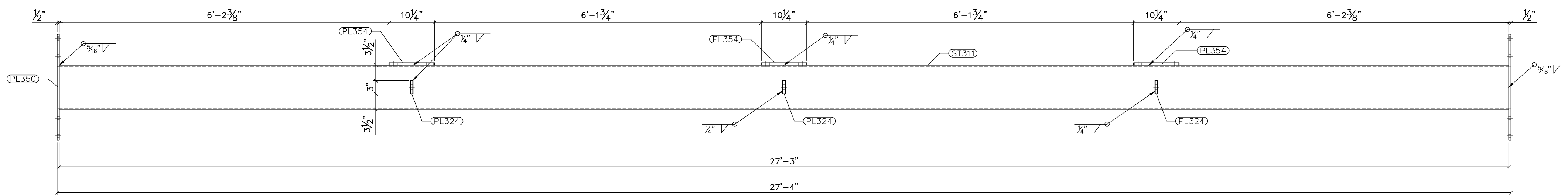
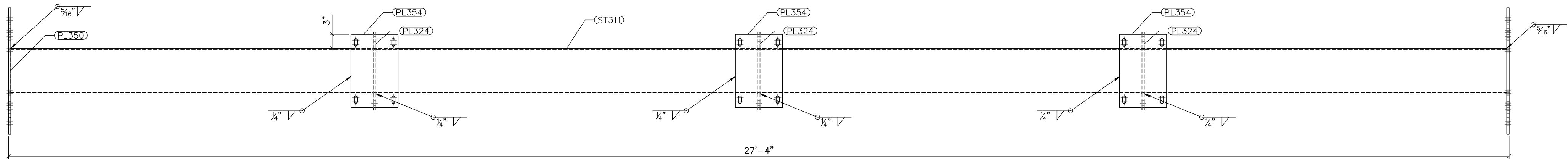

G311  
SCALE: 3/8"=1'-0"

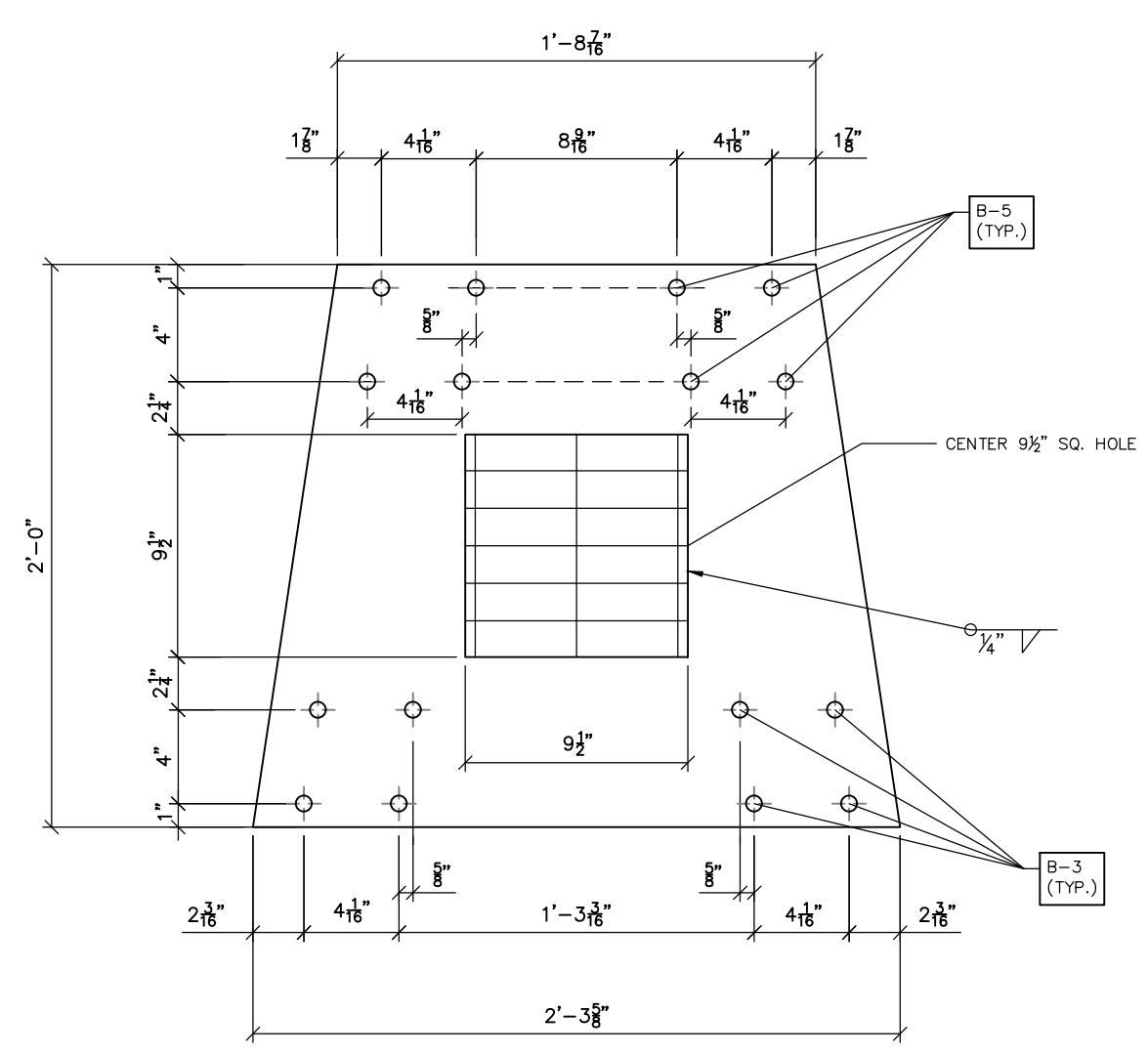
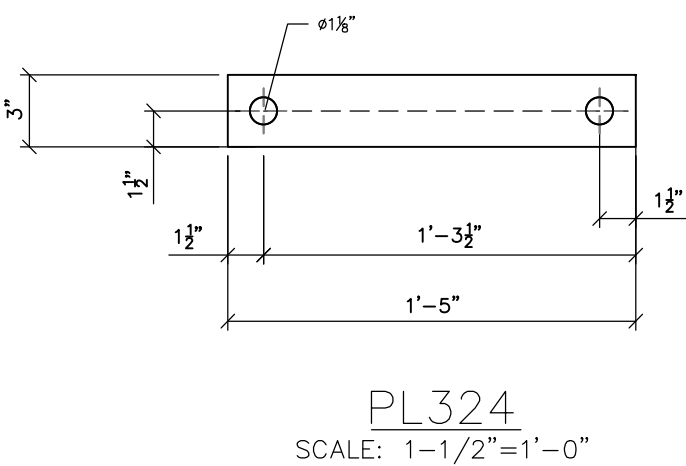
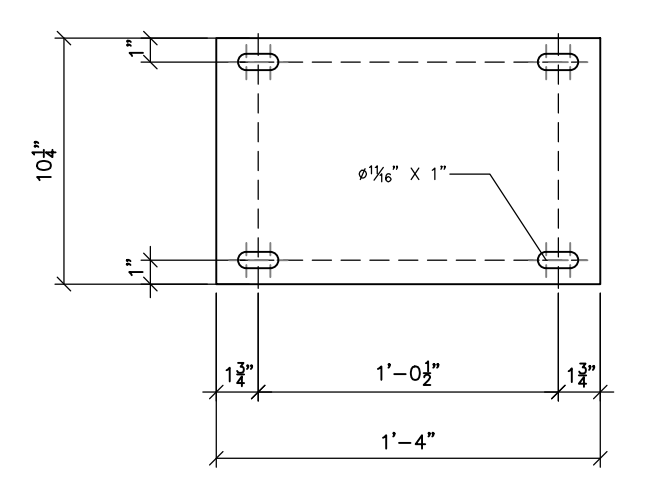

PRELIMINARY -  
DO NOT USE FOR  
CONSTRUCTION

© 05/2023

NO.	REVISIONS	ENG.	DATE
A	ISSUED FOR BID	VK	06/10/2023

PROJECT NAME: CUMBERLAND ROAD  
69 TO 15 X 25 KV  
SUBSTATION

DRAWING TITLE: A-FRAME STEEL DETAILS

DRAWN BY:	DJD
CHECKED BY:	VK
APPROVED BY:	VK
DATE:	05/10/2023
SCALE:	AS SHOWN
FILE NUMBER:	12510
SHEET:	

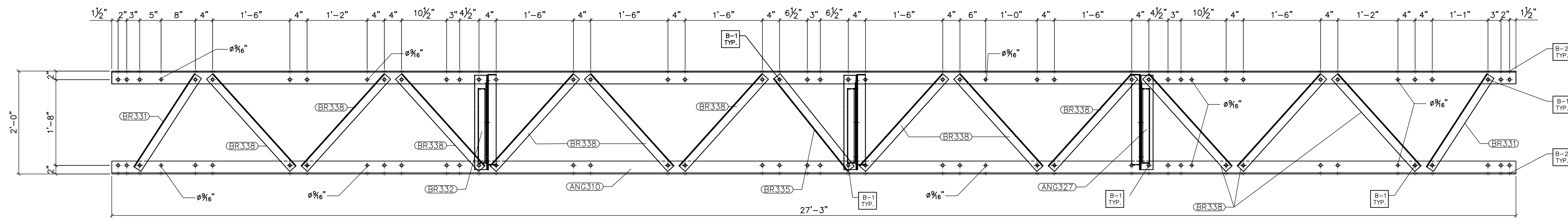

G310 BOX TRUSS  
(ALL FOR SIDES ALIKE)  
SCALE: 3/4"=1'-0"

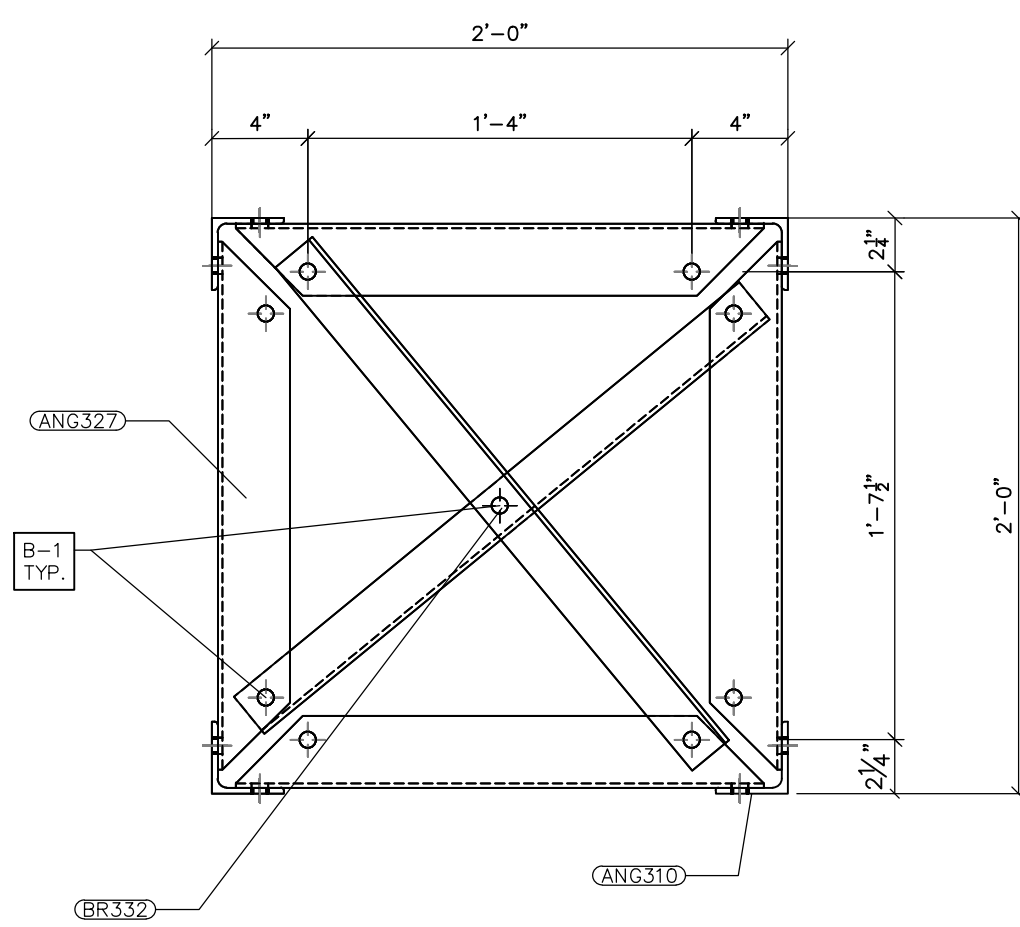

TYPICAL X-BRACE  
SCALE: 1-1/2"=1'-0"

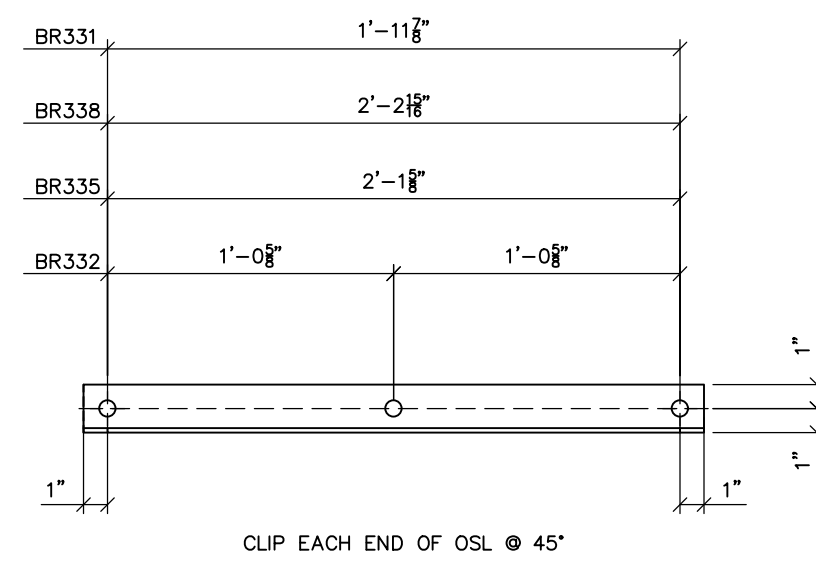

BR331 FRONT VIEW  
SCALE: 1-1/2"=1'-0"

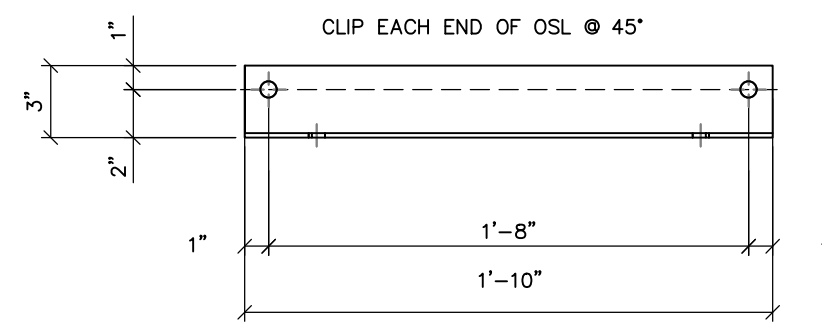

ANG327 FRONT VIEW  
SCALE: 1-1/2"=1'-0"

- NOTES:
- 1) ASTM 325 ERECTION BOLTS
  - 2) ALL HOT DIP GALVANIZED AFTER FABRICATION (ASTM A123)
  - 3) ALL HOLES 11/16" DIA. FOR 5/8" DIA. BOLTS UNLESS NOTED
  - 4) PIECE MARK STAMPED INTO METAL WITH NOT LESS THAN 3/8" HIGH CHARACTERS BEFORE GALVANIZING
  - 5) ALL WELDING ELECTRODES SHALL BE E7021
  - 6) EDGE DISTANCE 1" UNLESS NOTED

BILL OF MATERIAL				
POS. NO.	QTY	DESC.	LENGTH	WEIGHT
<b>G310</b>	<b>1</b>	<b>FOR ONE GROUP G310:</b>		
ANG310	4	L3x3x1/4	27'-3"	534.10
ANG327	12	L3x3x3/16	1'-10"	81.62
BR331	8	L2x2x3/16	2'-1 7/8"	42.04
BR332	6	L2x2x3/16	2'-3 1/4"	33.21
BR335	4	L2x2x3/16	2'-3 5/8"	22.46
BR338	48	L2x2x3/16	2'-4 15/16"	282.43
			BLACK WEIGHT:	995.86 LBS.
			GALVANIZED WEIGHT:	39.83 LBS.
			TOTAL WEIGHT:	1035.69 LBS.



PRELIMINARY -  
DO NOT USE FOR  
CONSTRUCTION

© 05/2023

NO.	ISSUED FOR BID	REVISIONS	ENG.	DATE
			VK	06/10/2023
A				

PROJECT NAME: CUMBERLAND ROAD  
69 TO 15 X 25 KV  
SUBSTATION

DRAWING TITLE:  
A-FRAME STEEL DETAILS

DRAWN BY:	DJD
CHECKED BY:	VK
APPROVED BY:	VK
DATE:	05/10/2023
SCALE:	AS SHOWN
FILE NUMBER:	12510
SHEET:	

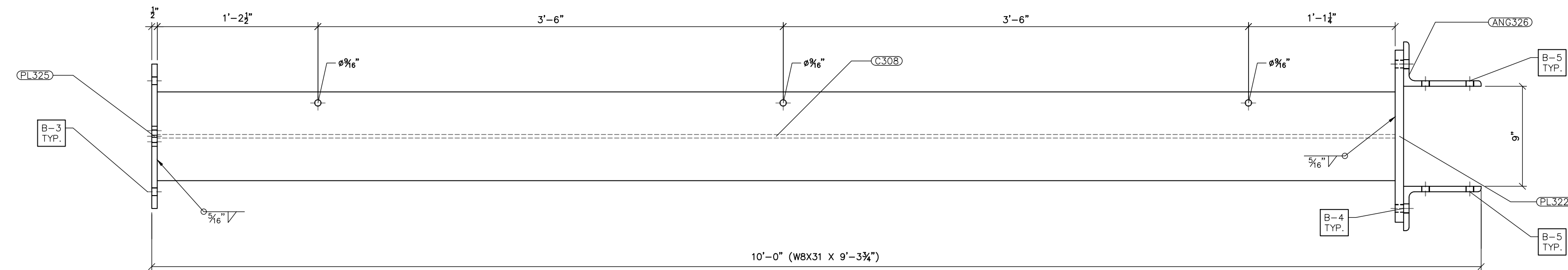

G308 FRONT VIEW  
SCALE: 3/4"=1'-0"

- NOTES:
- 1) ASTM 325 ERECTION BOLTS
  - 2) ALL HOT DIP GALVANIZED AFTER FABRICATION (ASTM A123)
  - 3) ALL HOLES 1/16" DIA. FOR 5/8" DIA. BOLTS UNLESS NOTED
  - 4) PIECE MARK STAMPED INTO METAL WITH NOT LESS THAN 3/8" HIGH CHARACTERS BEFORE GALVANIZING
  - 5) ALL WELDING ELECTRODES SHALL BE E7021
  - 6) EDGE DISTANCE 1" UNLESS NOTED

BILL OF MATERIAL			
POS. NO.	QTY	DESC.	WEIGHT
<b>G308</b>	<b>2</b>	<b>FOR ONE GROUP G308:</b>	
PL322	1	PL 3/4"x1'-3 1/2"	51.20
PL325	1	PL 1/2"x1'-1"	33.24
ANG326	2	L7x4x1/2	60.79
C308	1	W8x31	288.69
BLACK WEIGHT:			416.59 LBS.
GALVANIZED WEIGHT:			17.36 LBS.
TOTAL WEIGHT:			433.95 LBS.



**Booth & Associates**  
2200 Rowwood Drive Suite 300, Raleigh NC 27607  
NC F 0221



**PRELIMINARY -  
DO NOT USE FOR  
CONSTRUCTION**

© 05/2023

NO.	ISSUED FOR BID	REVISIONS	ENG.	DATE
			VK	06/10/2023

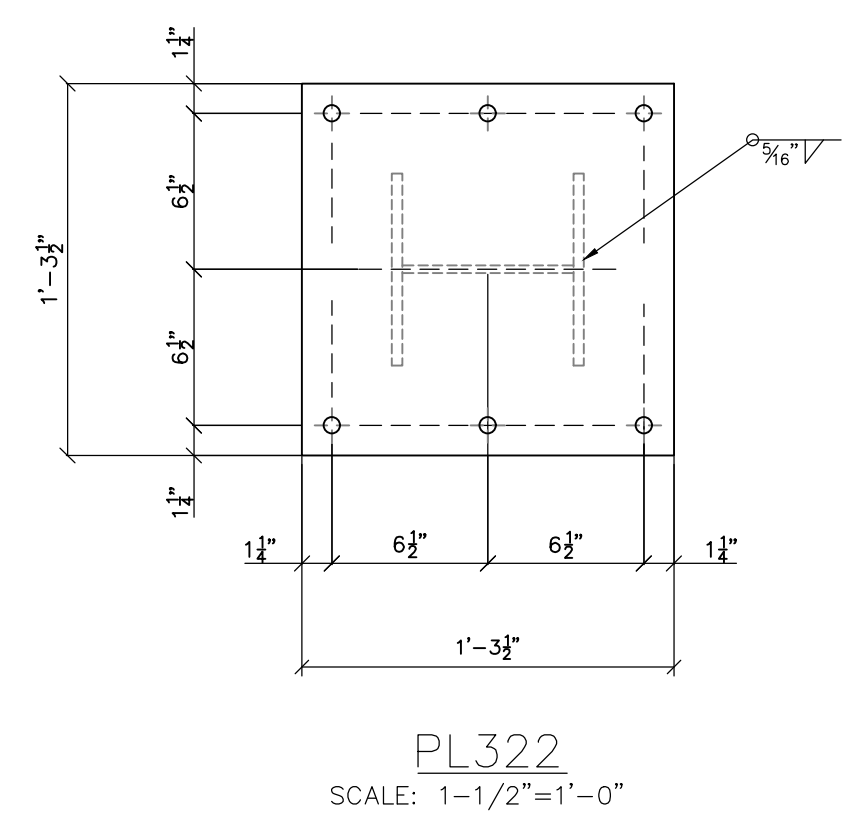

PL322  
SCALE: 1-1/2"=1'-0"

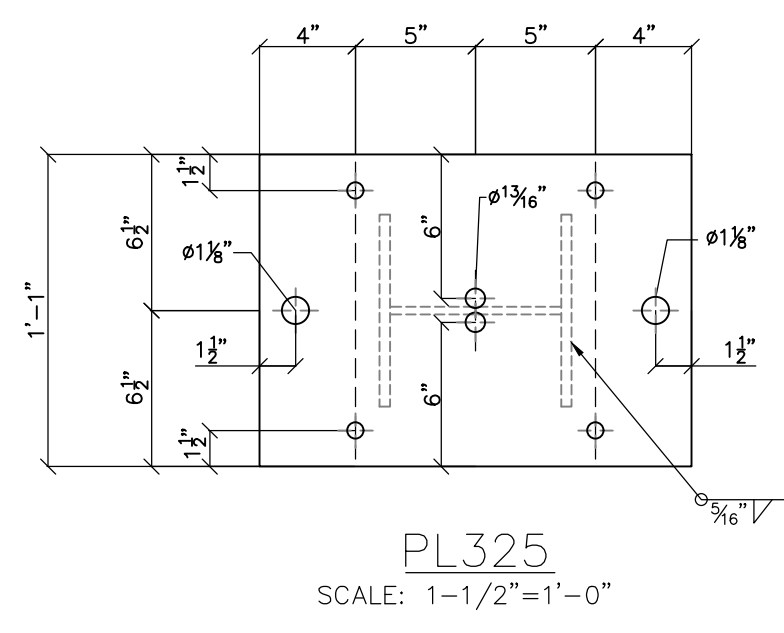

PL325  
SCALE: 1-1/2"=1'-0"

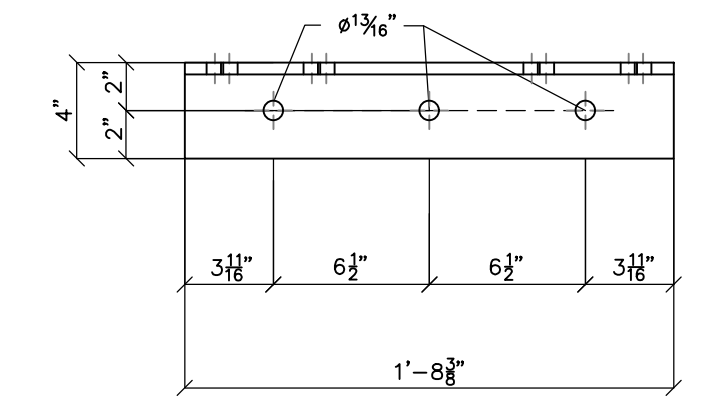

TOP VIEW

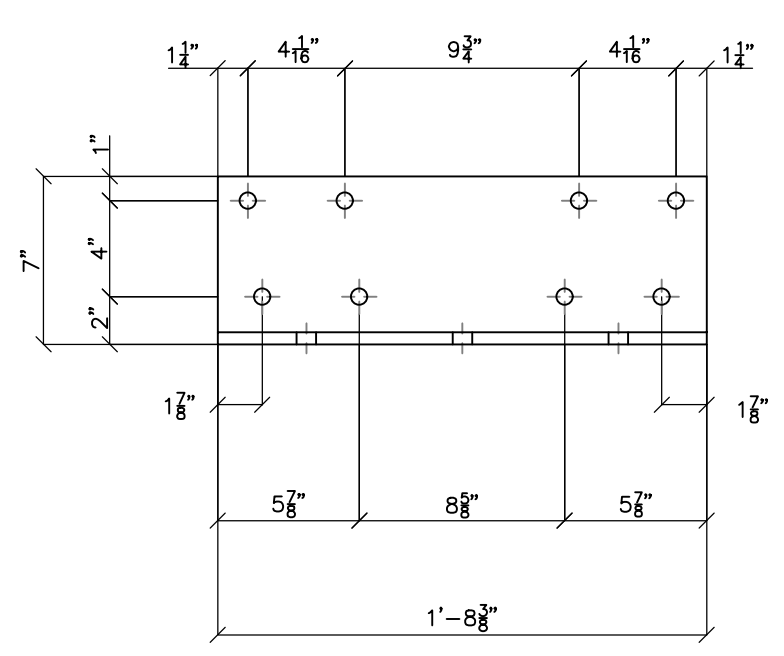

ANG326 FRONT VIEW

ANG326  
SCALE: 1-1/2"=1'-0"

PROJECT NAME: CUMBERLAND ROAD  
69 TO 15 X 25 KV  
SUBSTATION

DRAWING TITLE:  
**A-FRAME STEEL DETAILS**

DRAWN BY:	DJD
CHECKED BY:	VK
APPROVED BY:	VK
DATE:	05/10/2023
SCALE:	AS SHOWN
FILE NUMBER:	12510
SHEET:	



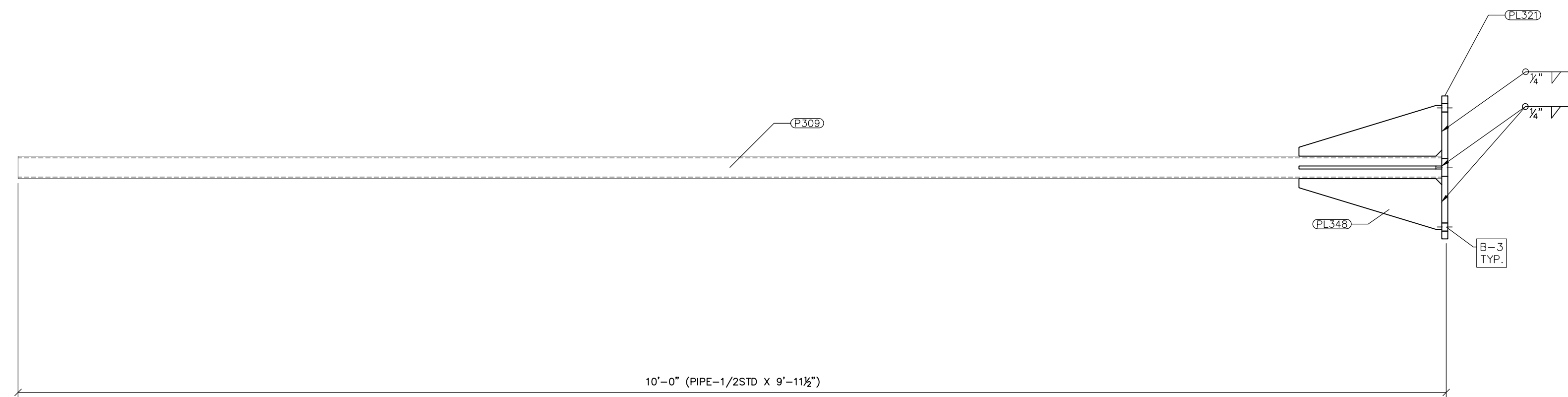

FRONT VIEW

10'-0" (PIPE-1/2STD X 9'-11 1/2")

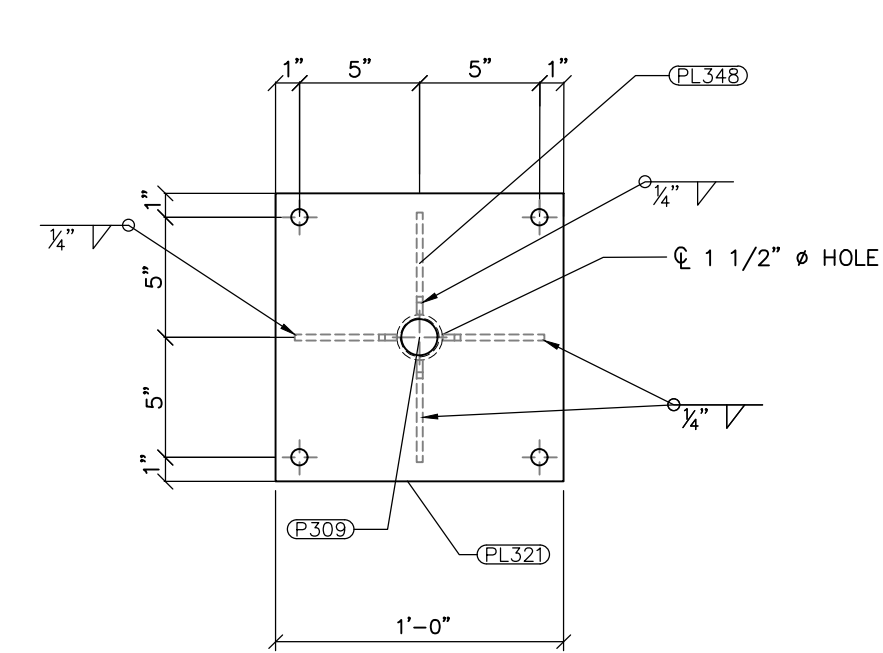

RIGHT VIEW

- NOTES:
- 1) ASTM 325 ERECTION BOLTS
  - 2) ALL HOT DIP GALVANIZED AFTER FABRICATION (ASTM A123)
  - 3) ALL HOLES 11/16" DIA. FOR 5/8" DIA. BOLTS UNLESS NOTED
  - 4) PIECE MARK STAMPED INTO METAL WITH NOT LESS THAN 3/8" HIGH CHARACTERS BEFORE GALVANIZING
  - 5) ALL WELDING ELECTRODES SHALL BE E7021
  - 6) EDGE DISTANCE 1" UNLESS NOTED

BILL OF MATERIAL				
POS. NO.	QTY	DESC.	LENGTH	WEIGHT
<b>G309</b>	<b>2</b>	<b>FOR ONE GROUP G309:</b>		
PL321	1	PL 1/2"x1"	1'	20.46
P309	1	PIPE-1/2STD	9'-11 1/2"	27.09
PL348	2	BAR 5 X 1/4	1'-0 1/2"	8.74
			BLACK WEIGHT:	56.29 LBS.
			GALVANIZED WEIGHT:	2.25 LBS.
			TOTAL WEIGHT:	58.54 LBS.

G309  
SCALE: 1-1/2"=1'-0"

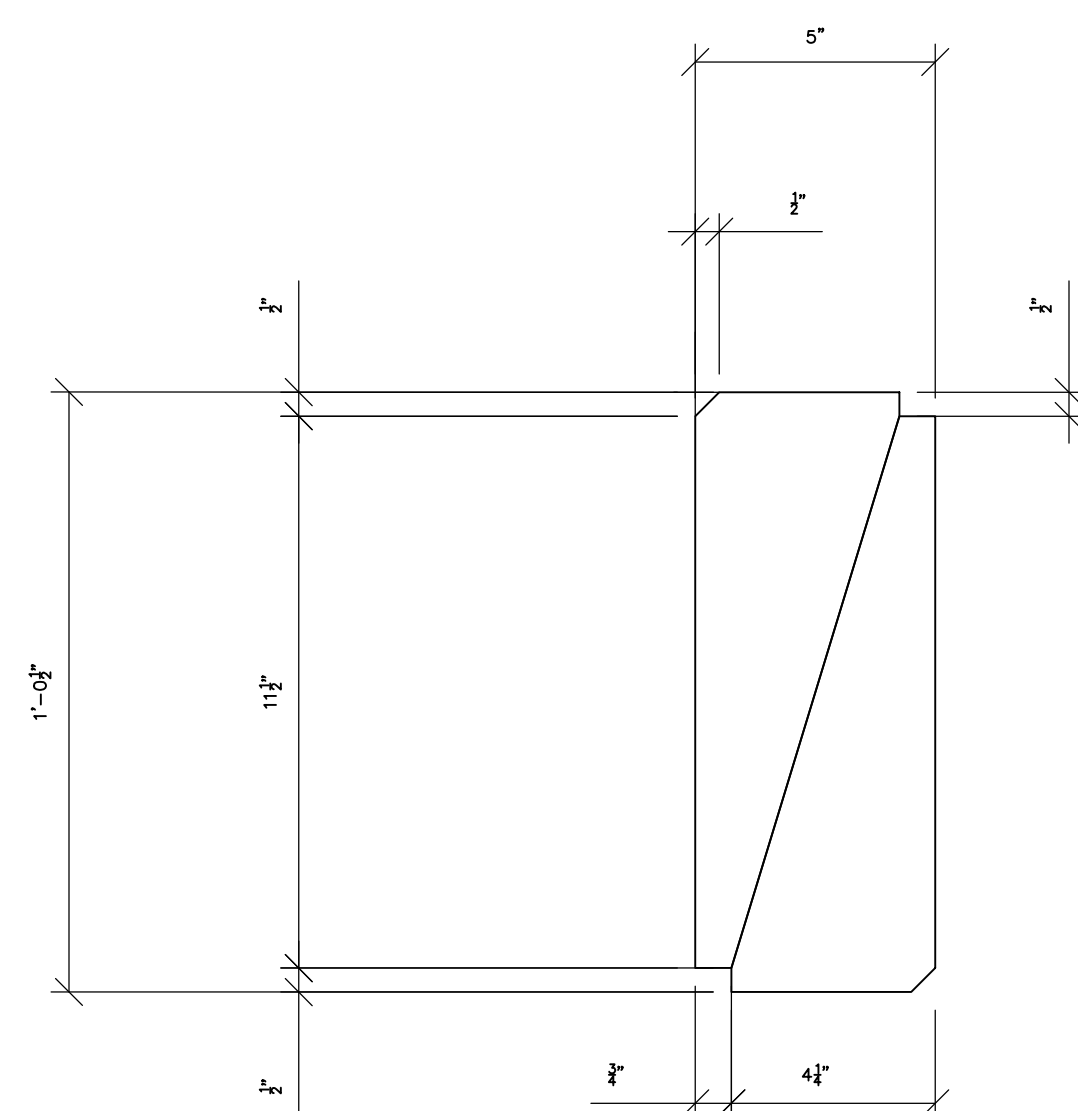

PL348  
(MAKES TWO)  
SCALE: 3"=1'-0"



PRELIMINARY -  
DO NOT USE FOR  
CONSTRUCTION

© 05/2023

NO.	ISSUED FOR BID	REVISIONS	ENG.	DATE
A			VK	06/10/2023

PROJECT NAME: CUMBERLAND ROAD  
69 TO 15 X 25 KV  
SUBSTATION

DRAWING TITLE:  
A-FRAME STEEL DETAILS

DRAWN BY:	DJD
CHECKED BY:	VK
APPROVED BY:	VK
DATE:	05/10/2023
SCALE:	AS SHOWN
FILE NUMBER:	12510
SHEET:	

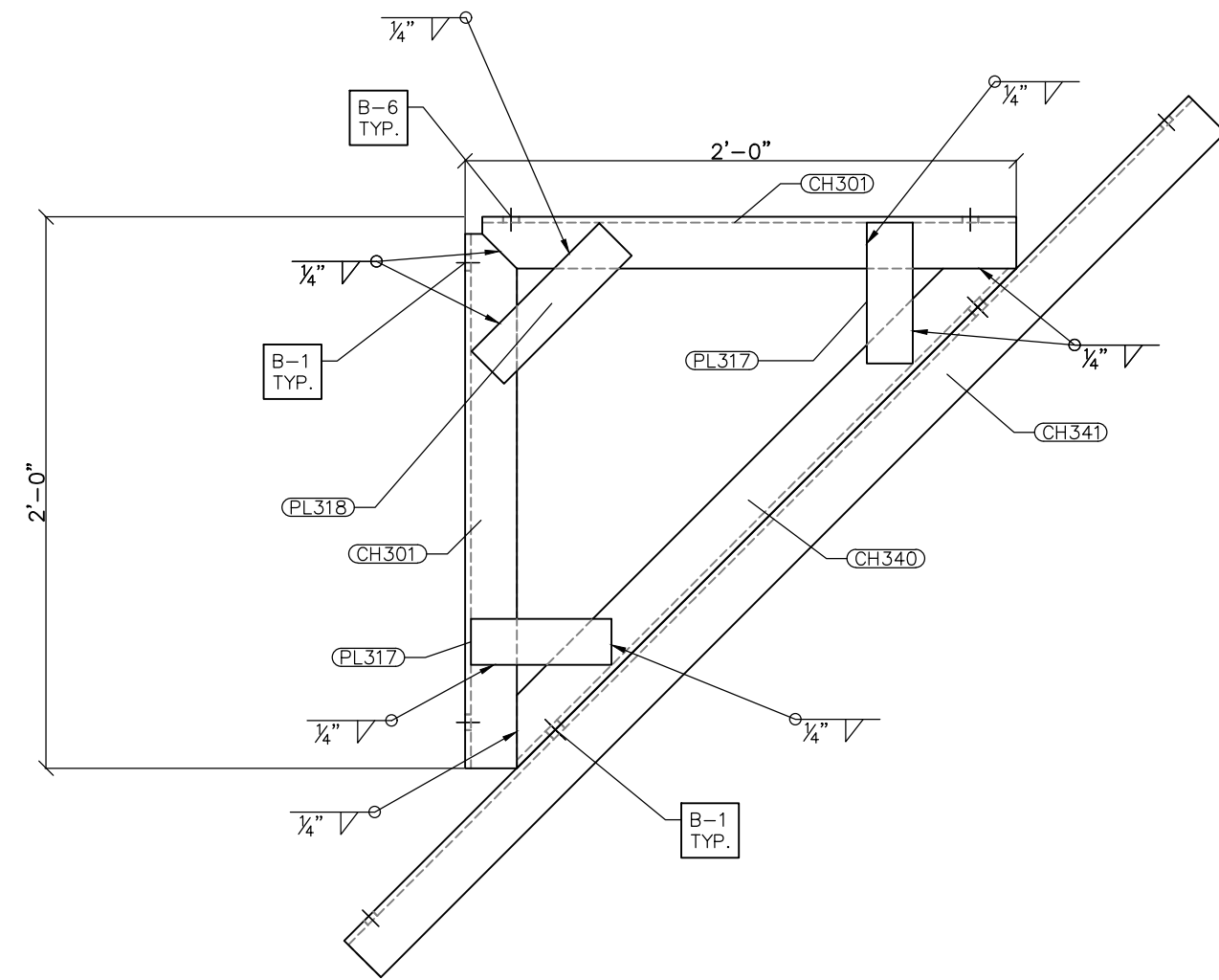

G301 FRONT VIEW  
SCALE: 1-1/2"=1'-0"

- NOTES:
- 1) ASTM 325 ERECTION BOLTS
  - 2) ALL HOT DIP GALVANIZED AFTER FABRICATION (ASTM A123)
  - 3) ALL HOLES 11/16" DIA. FOR 5/8" DIA. BOLTS UNLESS NOTED
  - 4) PIECE MARK STAMPED INTO METAL WITH NOT LESS THAN 3/8" HIGH CHARACTERS BEFORE GALVANIZING
  - 5) ALL WELDING ELECTRODES SHALL BE E7021
  - 6) EDGE DISTANCE 1" UNLESS NOTED

BILL OF MATERIAL				
POS. NO.	QTY	DESC.	LENGTH	WEIGHT
<b>G301</b>	<b>6</b>	<b>FOR ONE GROUP G301:</b>		
CH301	2	C8x11.5	1'-11 1/4"	44.56
CH340	1	C8x11.5	2'-6 3/4"	29.48
CH341	1	C8x11.5	4'-4"	49.83
PL317	4	PL 1/4"x2"	6 1/8"	3.47
PL318	2	PL 1/4"x2"	7 7/8"	2.23
			BLACK WEIGHT:	129.57 LBS.
			GALVANIZED WEIGHT:	5.18 LBS.
			TOTAL WEIGHT:	134.75 LBS.

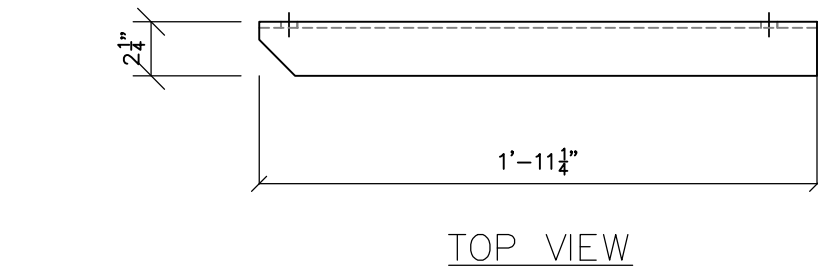

TOP VIEW

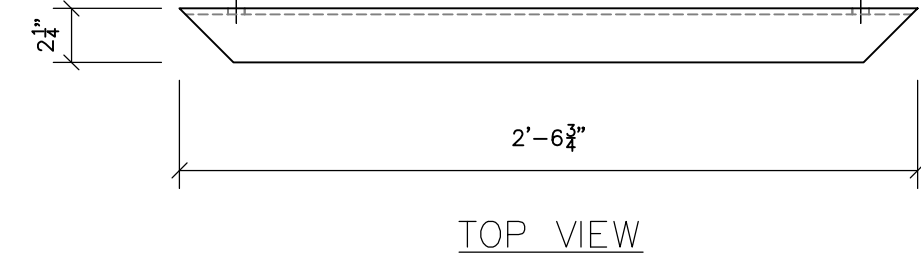

TOP VIEW

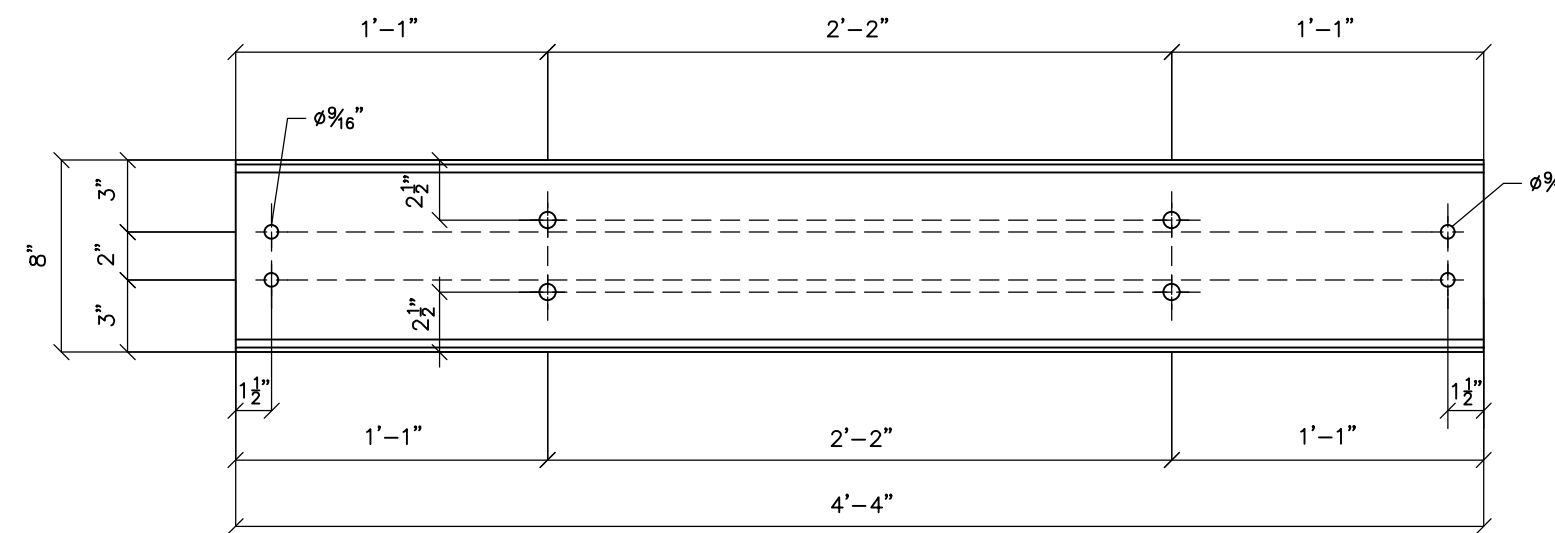

CH341 FRONT VIEW  
SCALE: 1-1/2"=1'-0"

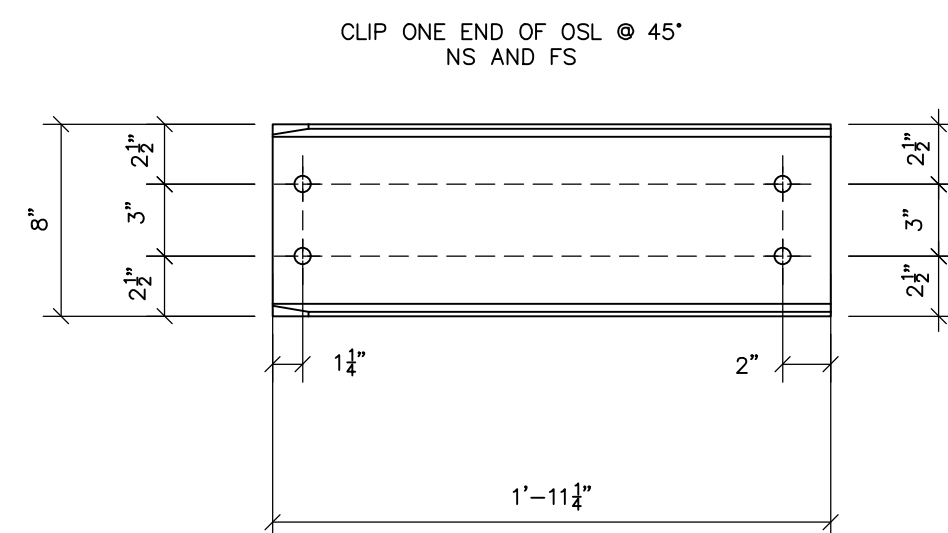

FRONT VIEW

CH301  
SCALE: 1-1/2"=1'-0"

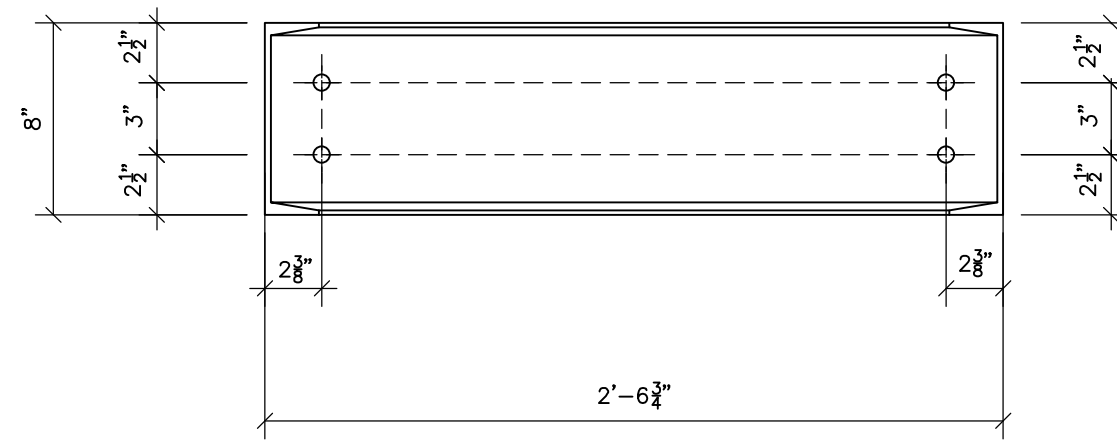

FRONT VIEW

CH340  
SCALE: 1-1/2"=1'-0"



PRELIMINARY -  
DO NOT USE FOR  
CONSTRUCTION

© 05/2023

NO.	ISSUED FOR BID	REVISIONS	ENG.	DATE
A			VK	05/10/2023

PROJECT NAME: CUMBERLAND ROAD  
69 TO 15 X 25 KV  
SUBSTATION

DRAWING TITLE:  
A-FRAME STEEL DETAILS

DRAWN BY:	DJD
CHECKED BY:	VK
APPROVED BY:	VK
DATE:	05/10/2023
SCALE:	AS SHOWN
FILE NUMBER:	12510
SHEET:	

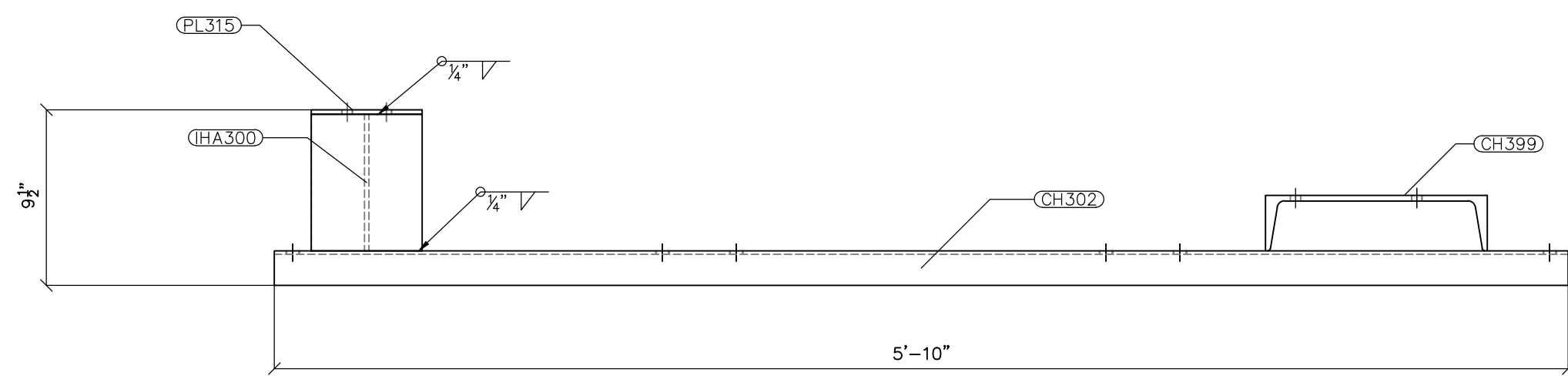

FRONT VIEW

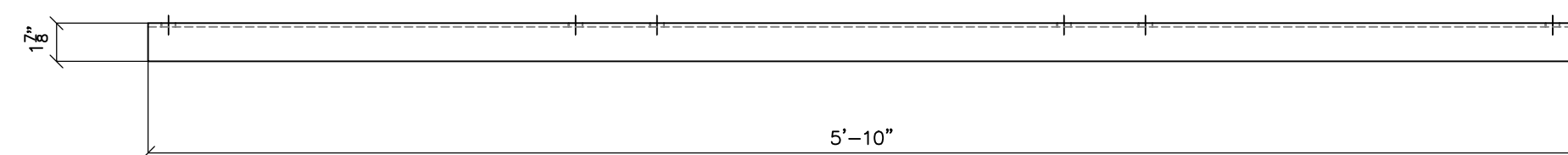

TOP VIEW

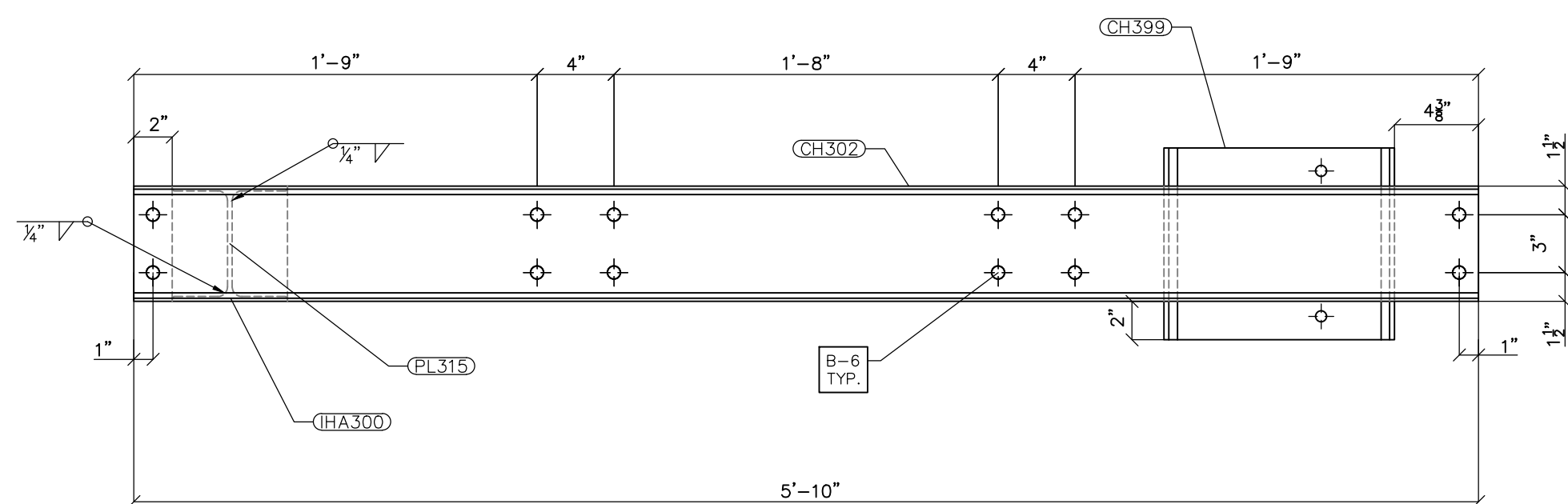

BOTTOM VIEW

G302  
SCALE: 1-1/2"=1'-0"

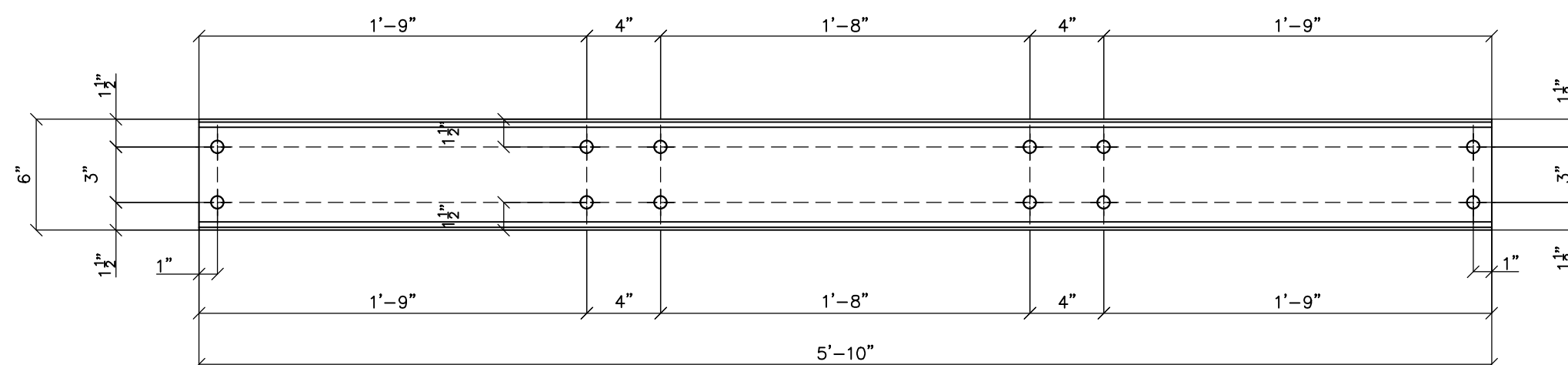

FRONT VIEW

CH302  
SCALE: 1-1/2"=1'-0"

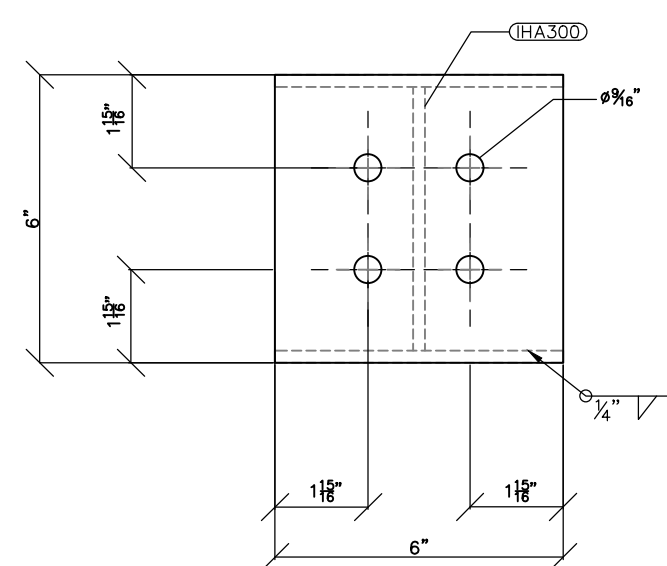

PL315  
SCALE: 3"=1'-0"

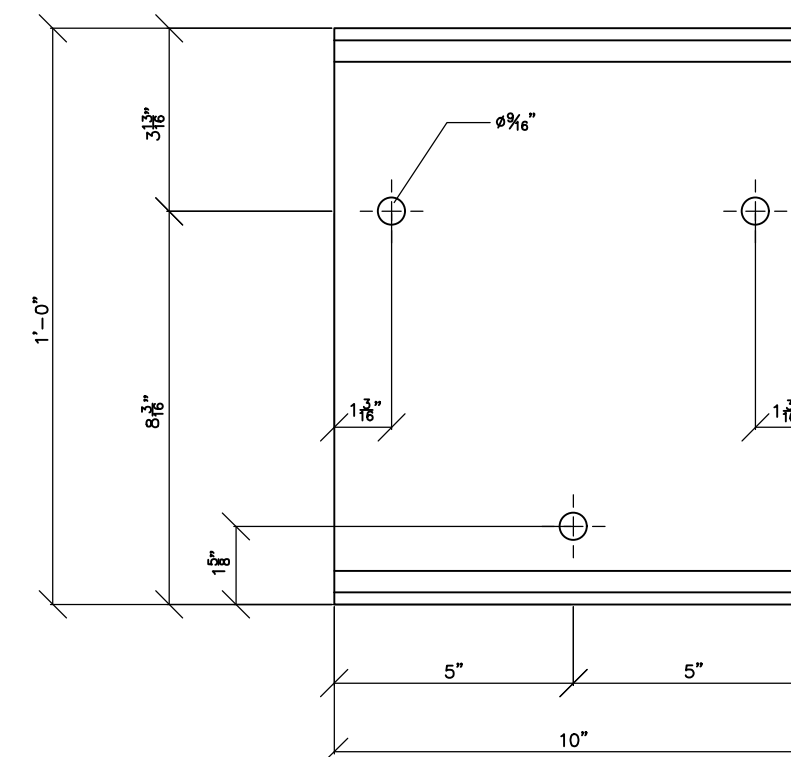

CH399  
SCALE: 3"=1'-0"

- NOTES:
- 1) ASTM 325 ERECTION BOLTS
  - 2) ALL HOT DIP GALVANIZED AFTER FABRICATION (ASTM A123)
  - 3) ALL HOLES 11/16" DIA. FOR 5/8" DIA. BOLTS UNLESS NOTED
  - 4) PIECE MARK STAMPED INTO METAL WITH NOT LESS THAN 3/8" HIGH CHARACTERS BEFORE GALVANIZING
  - 5) ALL WELDING ELECTRODES SHALL BE E7021
  - 6) EDGE DISTANCE 1" UNLESS NOTED

BILL OF MATERIAL				
POS. NO.	QTY	DESC.	LENGTH	WEIGHT
<b>G302</b>	<b>3</b>	<b>FOR ONE GROUP G302:</b>		
CH302	1	C6x8.2	5'-10"	47.83
CH399	1	C12x20.7	10"	17.22
HHA300	1	W6x15	7 5/8"	9.22
PL315	1	PL 1/4"x6"	6"	2.55
BLACK WEIGHT:			76.82	LBS.
GALVANIZED WEIGHT:			3.07	LBS.
TOTAL WEIGHT:			79.89	LBS.

PA Booth & Associates  
2200 Rarowoods Drive Suite 300, Raleigh, NC 27607  
NC F-021

**PRELIMINARY - DO NOT USE FOR CONSTRUCTION**

© 05/2023

NO.	ISSUED FOR BID	REVISIONS	ENG.	DATE
A			VK	05/10/2023

PROJECT NAME:	CUMBERLAND ROAD 69 TO 15 X 25 KV SUBSTATION
DRAWING TITLE:	A-FRAME STEEL DETAILS
DRAWN BY:	DJD
CHECKED BY:	VK
APPROVED BY:	VK
DATE:	05/10/2023
SCALE:	AS SHOWN
FILE NUMBER:	12510
SHEET:	AF-6



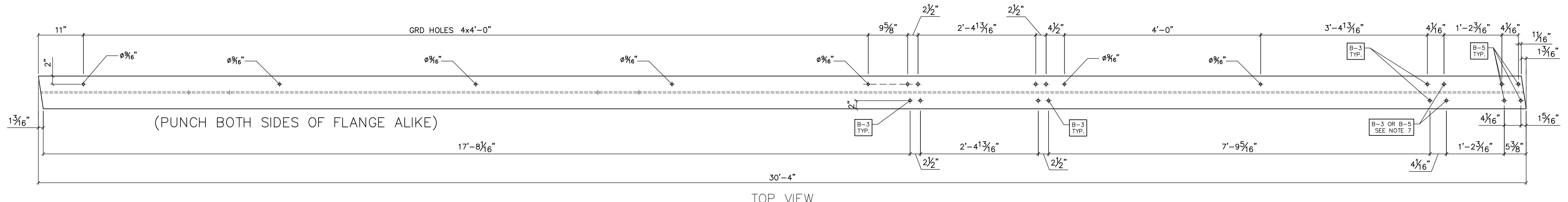

TOP VIEW

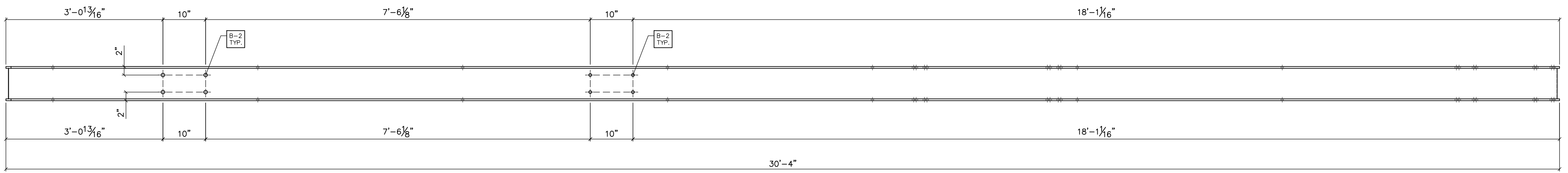

FRONT VIEW

CH312  
SCALE: 3/4"=1'-0"

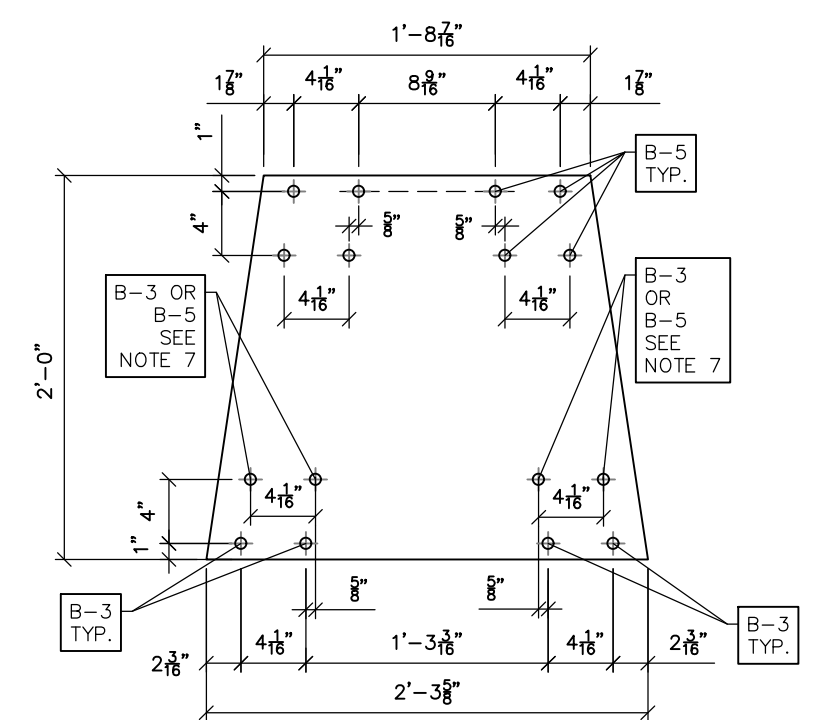

PL351  
SCALE: 1"=1'-0"

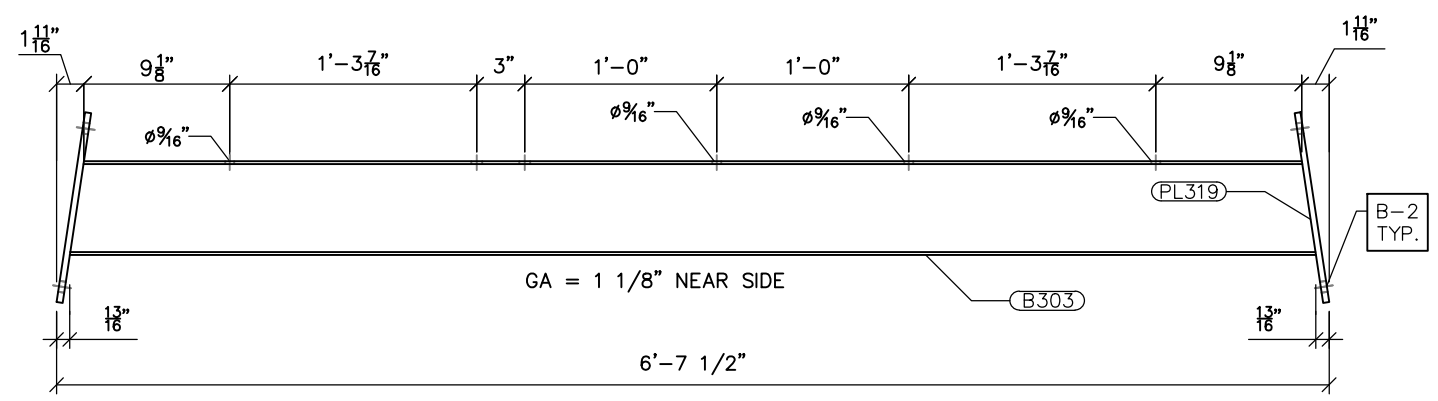

G303 FRONT VIEW  
SCALE: 1"=1'-0"

- NOTES:
- 1) ASTM 325 ERECTION BOLTS
  - 2) ALL HOT DIP GALVANIZED AFTER FABRICATION (ASTM A123)
  - 3) ALL HOLES 11/16" DIA. FOR 5/8" DIA. BOLTS UNLESS NOTED
  - 4) PIECE MARK STAMPED INTO METAL WITH NOT LESS THAN 3/8" HIGH CHARACTERS BEFORE GALVANIZING
  - 5) ALL WELDING ELECTRODES SHALL BE E7021
  - 6) EDGE DISTANCE 1" UNLESS NOTED
  - 7) ERECTION BOLT LENGTH VARIES WHERE NOTED IN CASES WHERE ANG 328 IS REQUIRED, B-5 SHALL BE USED. IN OTHER CASES, B-3 SHALL BE USED.

BILL OF MATERIAL			
POS. NO.	QTY	DESC	WEIGHT
<b>G303</b>	<b>2</b>	<b>FOR ONE GROUP G303:</b>	
B303	1	W6x9	58.41
PL319	2	PL 3/8"x6"	15.34
<b>INDIVIDUAL SINGLE PARTS:</b>			
PL351	2	PL 1/2"x2'-0"	376.01
C312	4	W8x31	7522.67
BASE323	4	PL 1 1/4"x1'-4"	725.93
BLACK WEIGHT:			8624.61 LBS.
GALVANIZED WEIGHT:			344.98 LBS.
TOTAL WEIGHT:			8969.59 LBS.



PRELIMINARY -  
DO NOT USE FOR  
CONSTRUCTION

© 05/2023

NO.	ISSUED FOR BID	REVISIONS	ENG.	DATE
A			VK	05/10/2023

PROJECT NAME: CUMBERLAND ROAD  
69 TO 15 X 25 KV  
SUBSTATION

DRAWING TITLE:  
A-FRAME STEEL DETAILS

DRAWN BY: DJD  
CHECKED BY: VK  
APPROVED BY: VK  
DATE: 05/10/2023  
SCALE: AS SHOWN  
FILE NUMBER: 12510  
SHEET:

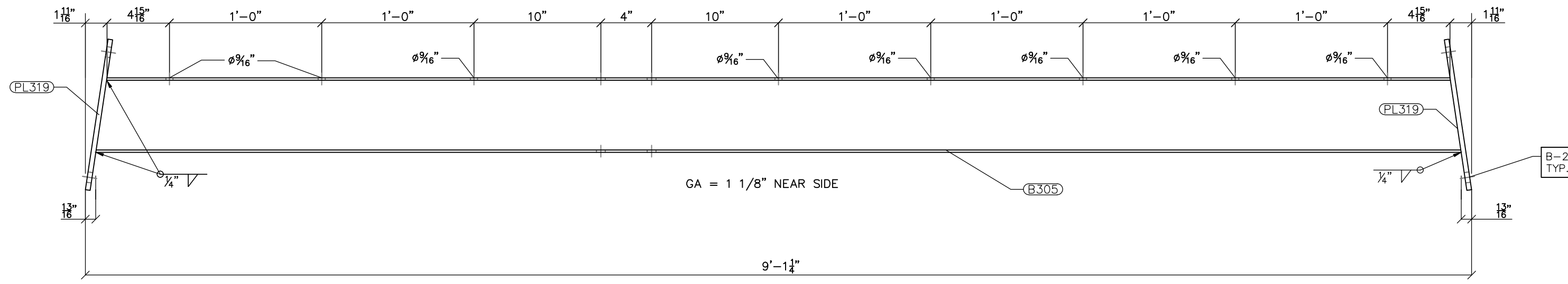

G305 FRONT VIEW  
SCALE: 1-1/2"=1'-0"

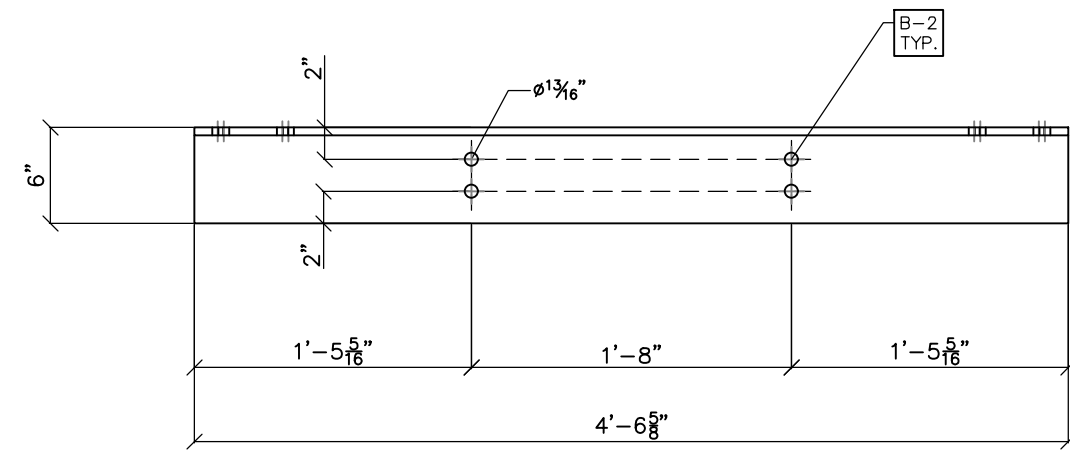

TOP VIEW

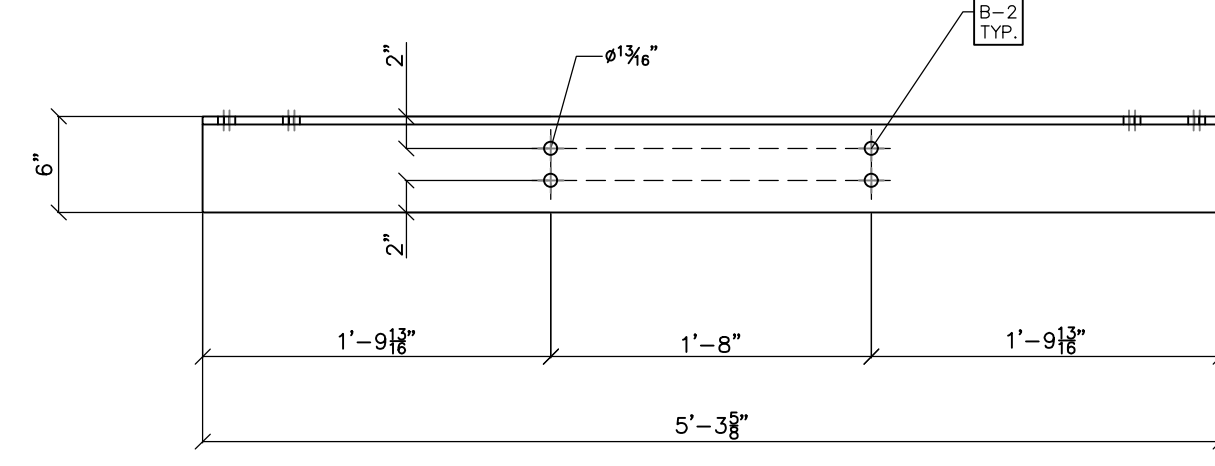

TOP VIEW

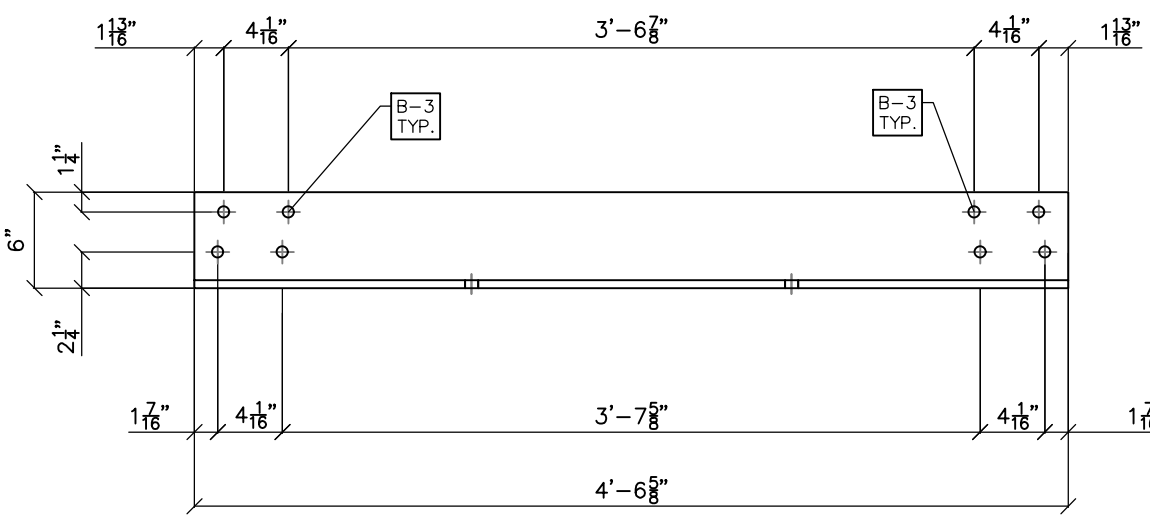

FRONT VIEW

ANG342  
SCALE: 1"=1'-0"

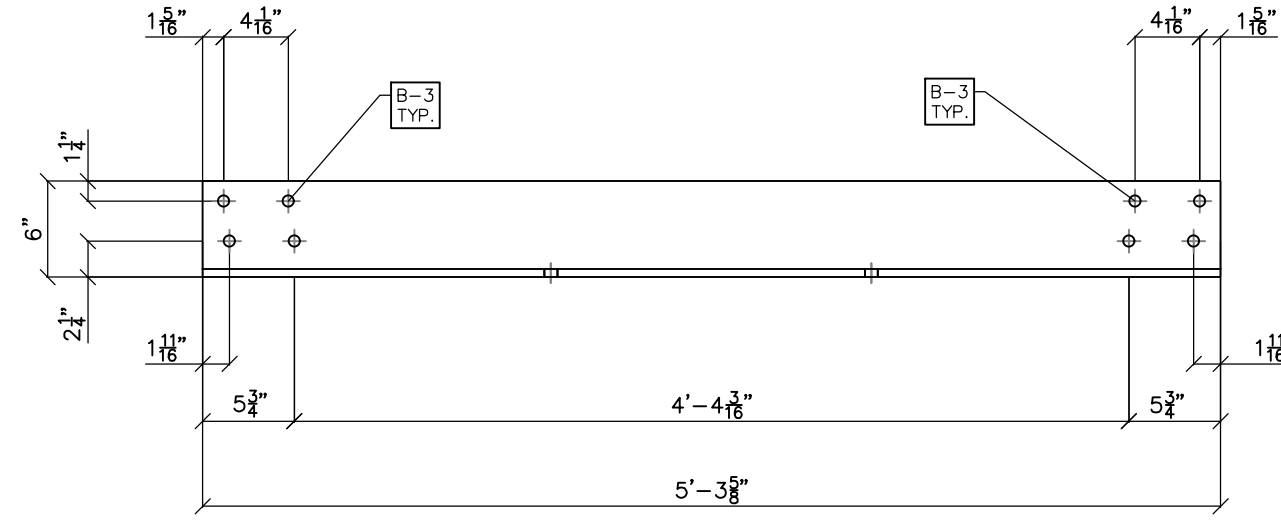

FRONT VIEW

ANG344  
SCALE: 1"=1'-0"

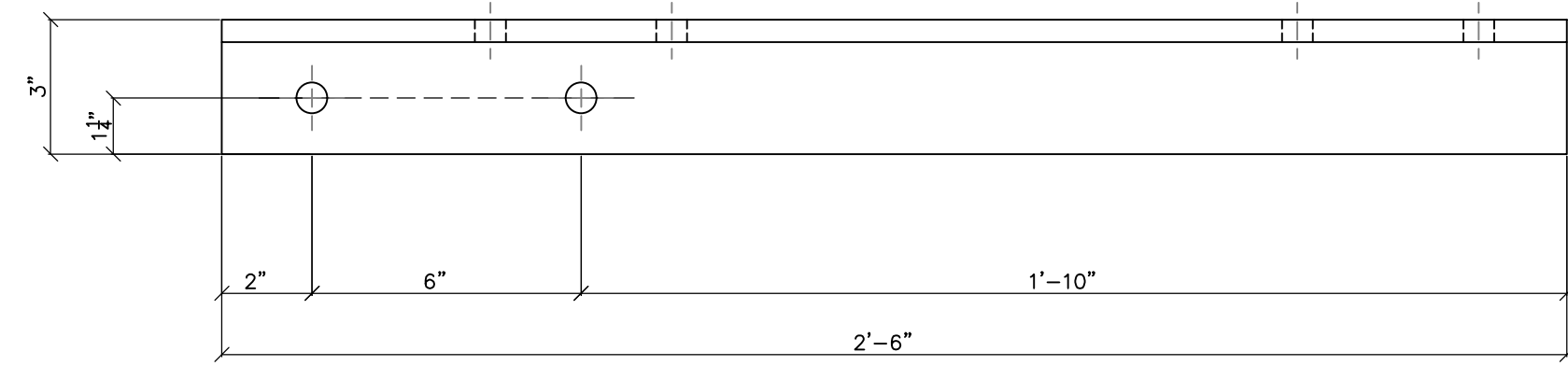

TOP VIEW

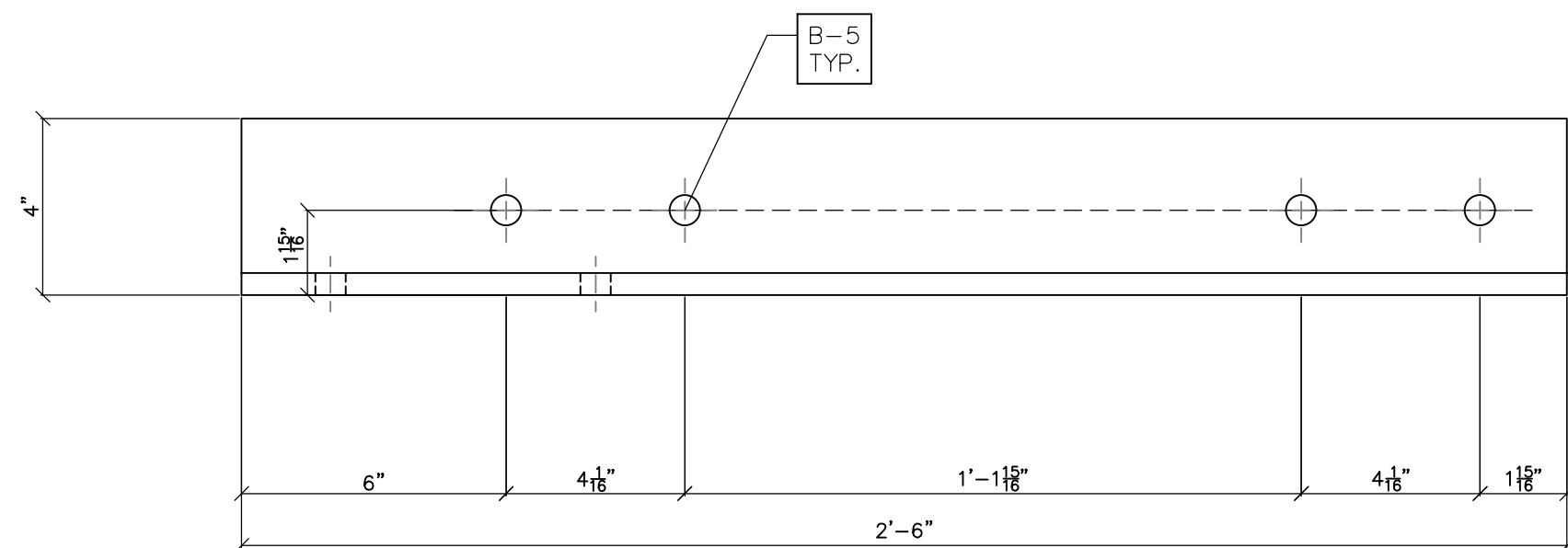

FRONT VIEW

ANG328  
SCALE: 3"=1'-0"

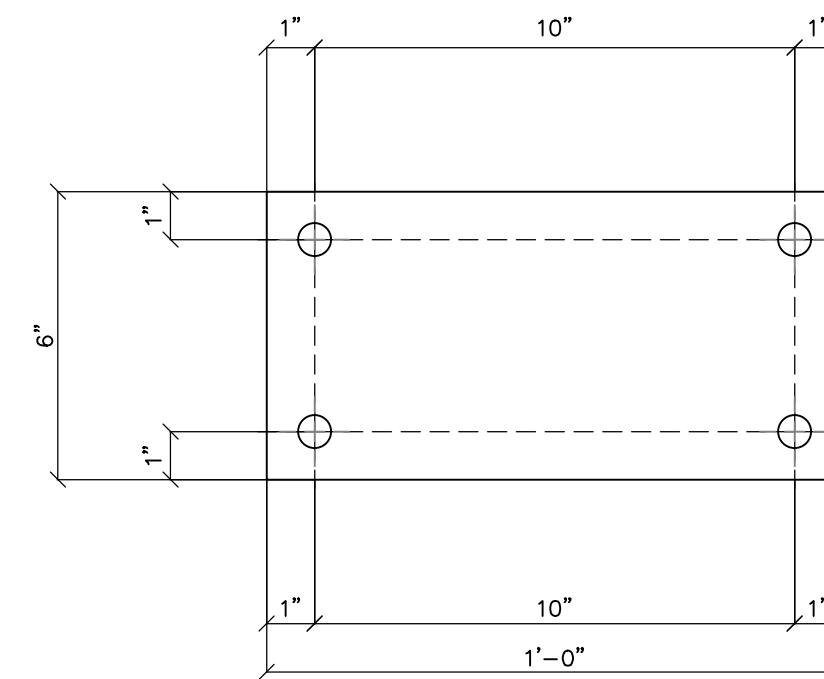

PL319  
SCALE: 3"=1'-0"

- NOTES:
- 1) ASTM 325 ERECTION BOLTS
  - 2) ALL HOT DIP GALVANIZED AFTER FABRICATION (ASTM A123)
  - 3) ALL HOLES 1/16" DIA. FOR 5/8" DIA. BOLTS UNLESS NOTED
  - 4) PIECE MARK STAMPED INTO METAL WITH NOT LESS THAN 3/8" HIGH CHARACTERS BEFORE GALVANIZING
  - 5) ALL WELDING ELECTRODES SHALL BE E7021
  - 6) EDGE DISTANCE 1" UNLESS NOTED
  - 7) ERECTION BOLT LENGTH VARIES WHERE NOTED IN CASES WHERE ANG 328 IS REQUIRED, B-5 SHALL BE USED. IN OTHER CASES, B-3 SHALL BE USED.

BILL OF MATERIAL				
POS. NO.	QTY	DESC.	LENGTH	WEIGHT
<b>G305</b>	<b>2</b>	<b>FOR ONE GROUP G305:</b>		
B305	1	W6x9	8'-11 5/8"	80.70
PL319	2	PL 3/8"x6"	1'	15.34
		<b>INDIVIDUAL SINGLE PARTS:</b>		
ANG328	1	L4x3x1/2	2'-6"	55.50
ANG342	2	L6x6x1/2	4'-6 5/8"	356.88
ANG344	2	L6x6x1/2	5'-3 5/8"	415.68
		BLACK WEIGHT:		828.06 LBS.
		GALVANIZED WEIGHT:		33.12 LBS.
		TOTAL WEIGHT:		861.18 LBS.



PRELIMINARY -  
DO NOT USE FOR  
CONSTRUCTION

© 05/2023

NO.	ISSUED FOR	REVISIONS	ENG.	DATE
A	ISSUED FOR BID		VK	05/10/2023

PROJECT NAME: CUMBERLAND ROAD  
69 TO 15 X 25 KV  
SUBSTATION

DRAWING TITLE:  
A-FRAME STEEL DETAILS

DRAWN BY:	DJD
CHECKED BY:	VK
APPROVED BY:	VK
DATE:	05/10/2023
SCALE:	AS SHOWN
FILE NUMBER:	12510
SHEET:	

AF-8

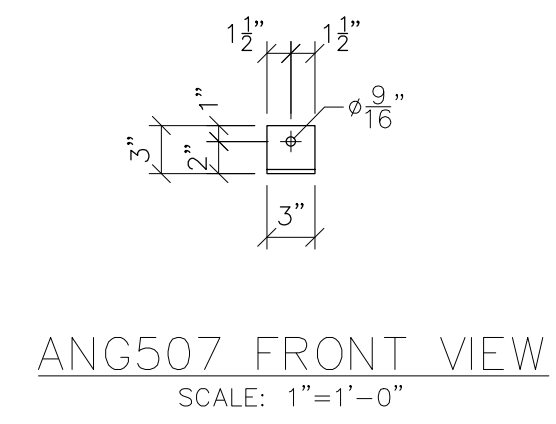
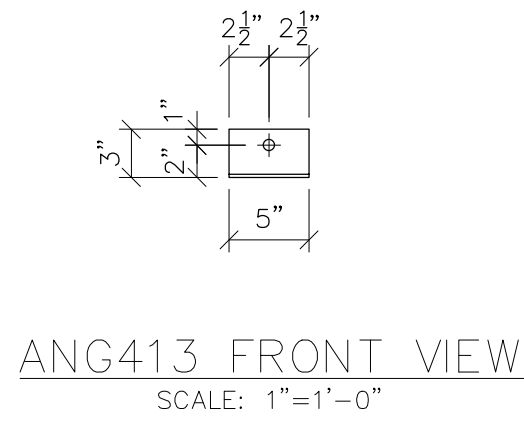
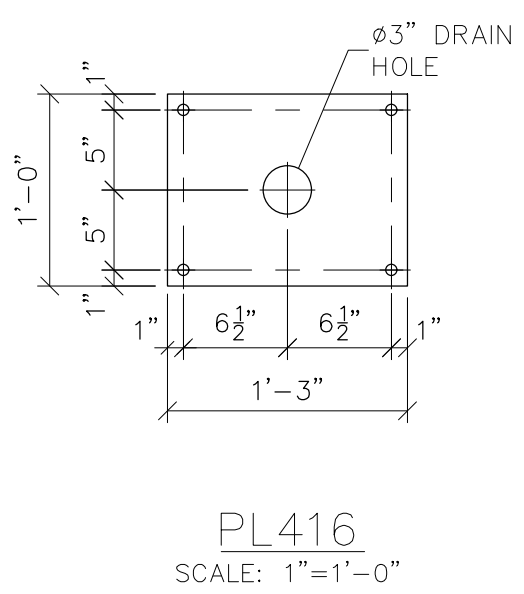
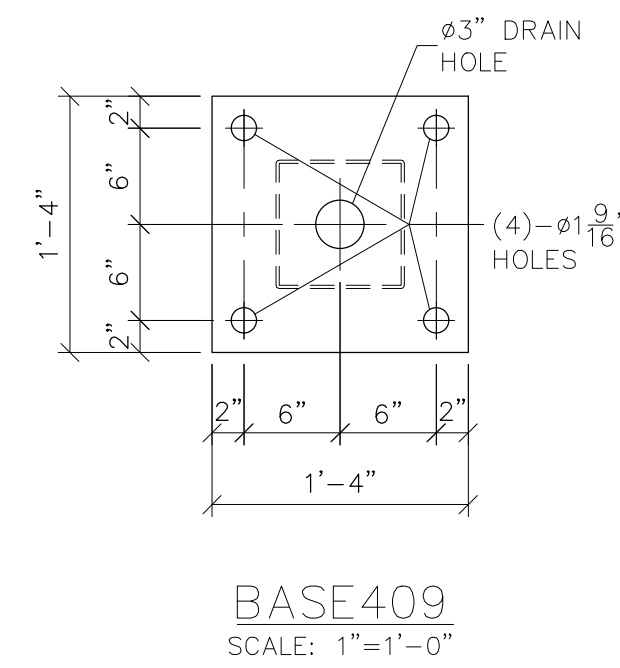
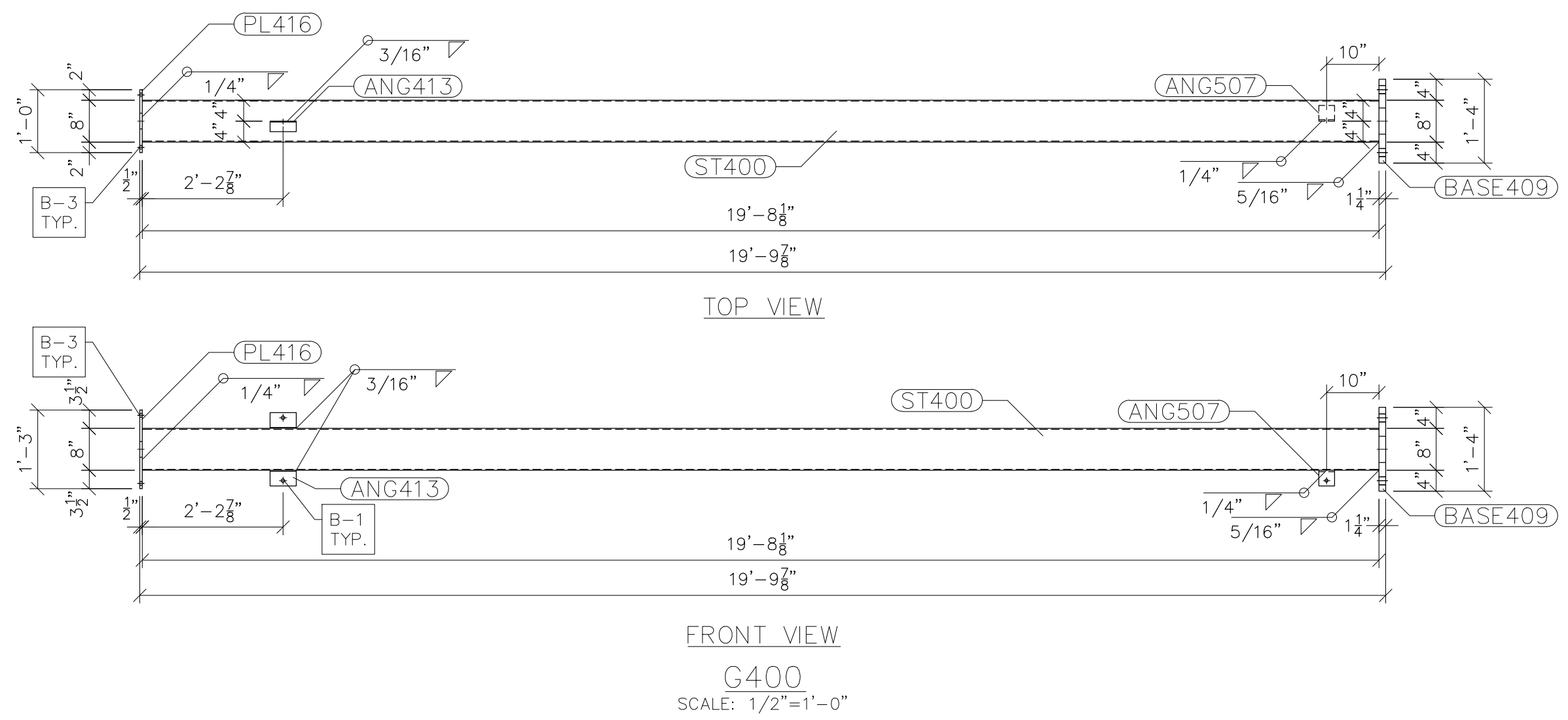

- NOTES:
- 1) ASTM 325 ERECTION BOLTS
  - 2) ALL HOT DIP GALVANIZED AFTER FABRICATION (ASTM A123)
  - 3) ALL HOLES 1 1/16" DIA. FOR 5/8" DIA. BOLTS UNLESS NOTED
  - 4) PIECE MARK STAMPED INTO METAL WITH NOT LESS THAN 3/8" HIGH CHARACTERS BEFORE GALVANIZING
  - 5) ALL WELDING ELECTRODES SHALL BE E7021
  - 6) EDGE DISTANCE 1" UNLESS NOTED

BILL OF MATERIAL			
POS. NO.	QTY	DESC.	WEIGHT
<b>G400</b>	<b>1</b>	<b>FOR ONE GROUP G400:</b>	
ANG413	2	L3x2x3/16	2.56
ANG507	1	L3x3x1/4	1.23
BASE409	1	PL 1 1/4"x1'-4"	90.93
PL416	1	PL 1/2"x1'-0"	25.57
ST400	1	HSS8x8x3/16	386.26
BLACK WEIGHT:			506.55 LBS.
GALVANIZED WEIGHT:			20.26 LBS.
TOTAL WEIGHT:			526.81 LBS.



PRELIMINARY -  
DO NOT USE FOR  
CONSTRUCTION

© 05/2023

NO.	REVISIONS	ENG.	DATE
A	ISSUED FOR BID	VK	06/10/2023

PROJECT NAME: CUMBERLAND ROAD  
69 TO 15 X 25 kV  
SUBSTATION

DRAWING TITLE: LOW SWITCH STAND

DRAWN BY:	DJD
CHECKED BY:	VK
APPROVED BY:	VK
DATE:	05/10/2023
SCALE:	AS SHOWN
FILE NUMBER:	12510
SHEET:	

- NOTES:
- 1) ASTM 325 ERECTION BOLTS
  - 2) ALL HOT DIP GALVANIZED AFTER FABRICATION (ASTM A123)
  - 3) ALL HOLES 11/16" DIA. FOR 5/8" DIA. BOLTS UNLESS NOTED
  - 4) PIECE MARK STAMPED INTO METAL WITH NOT LESS THAN 3/8" HIGH CHARACTERS BEFORE GALVANIZING
  - 5) ALL WELDING ELECTRODES SHALL BE E7021
  - 6) EDGE DISTANCE 1" UNLESS NOTED

BILL OF MATERIAL				
POS. NO.	QTY	DESC.	LENGTH	WEIGHT
<b>G400.1</b>	<b>1</b>	<b>FOR ONE GROUP G400.1:</b>		
ANG411	1	L3x3x1/2	6"	4.70
ANG413	2	L3x2x3/16	5"	2.56
ANG507	1	L3x3x1/4	3"	1.23
BASE409	1	PL 1/2"x1'-4"	1'-4"	90.93
CH451	1	C12x25	6"	12.50
PL416	1	PL 1/2"x1'-0"	1'-3"	25.57
ST400.1	1	HSS8x8x3/16	19'-8 1/8"	386.26
BLACK WEIGHT:				523.75 LBS.
GALVANIZED WEIGHT:				20.95 LBS.
TOTAL WEIGHT:				544.70 LBS.

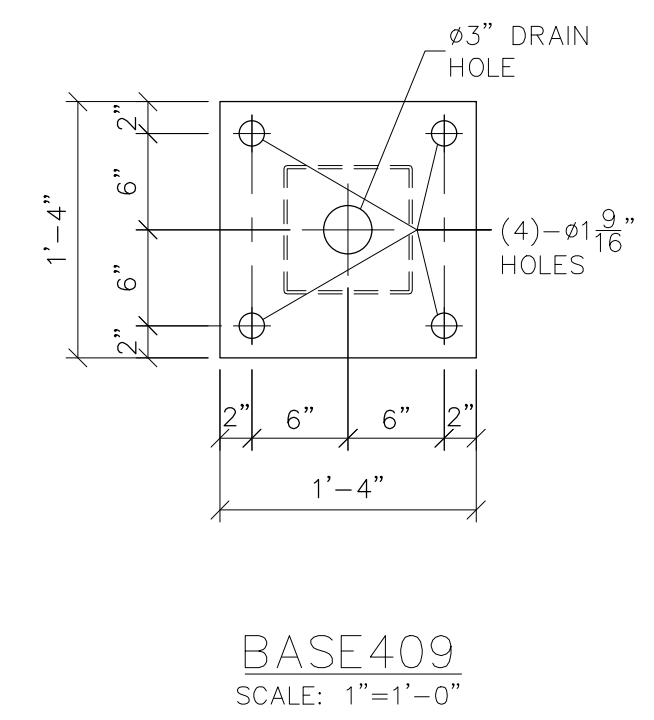
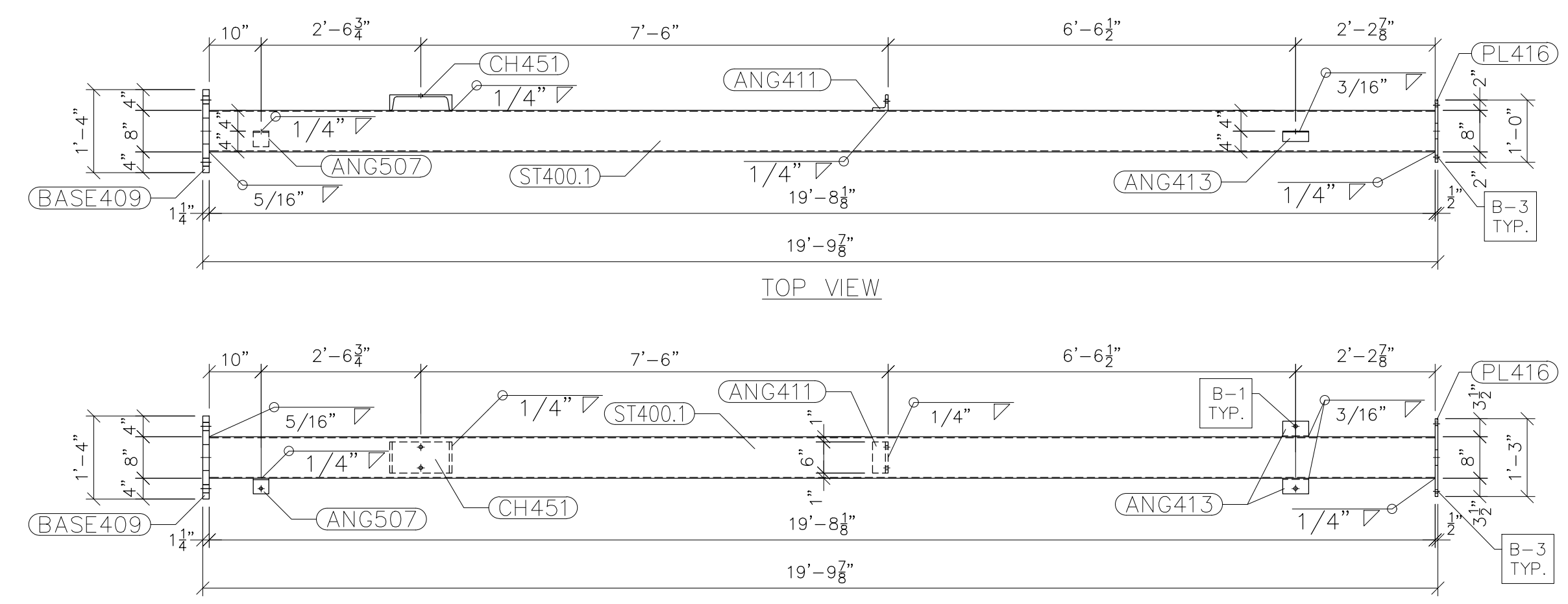

FRONT VIEW  
G400.1  
SCALE: 1/2"=1'-0"

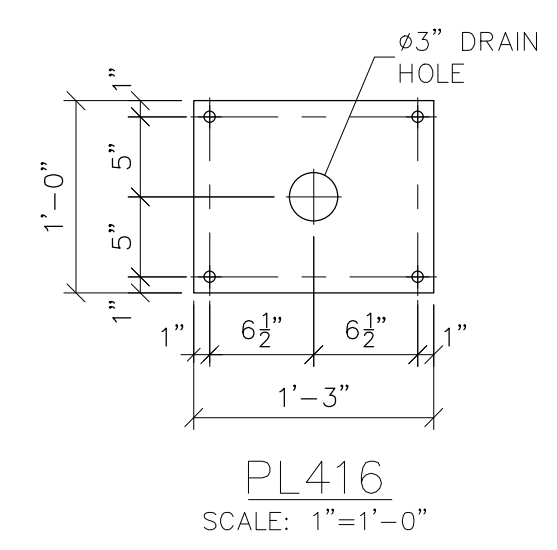

ANG413 FRONT VIEW  
SCALE: 1"=1'-0"

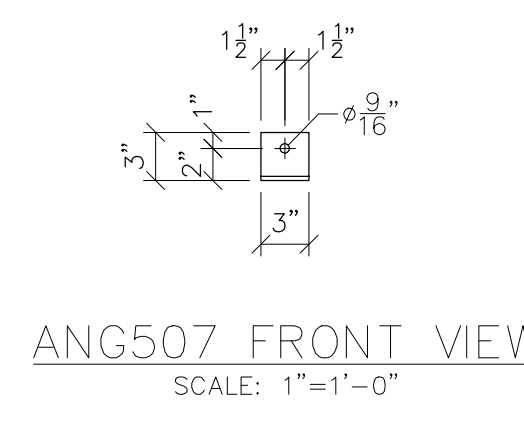

ANG507 FRONT VIEW  
SCALE: 1"=1'-0"

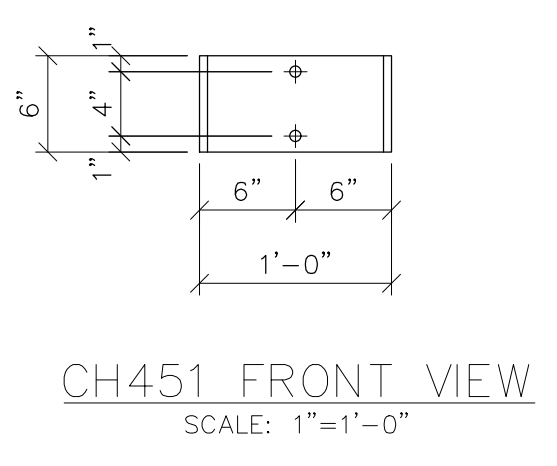

CH451 FRONT VIEW  
SCALE: 1"=1'-0"

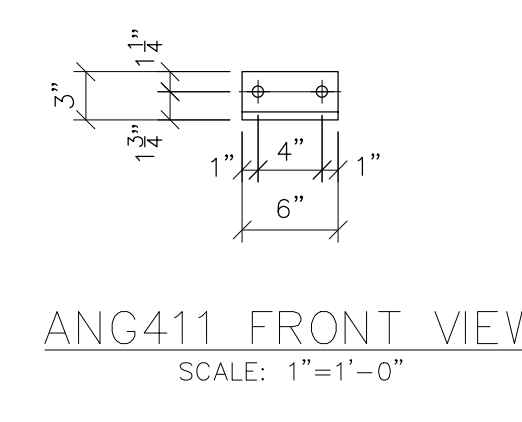

ANG411 FRONT VIEW  
SCALE: 1"=1'-0"



PRELIMINARY -  
DO NOT USE FOR  
CONSTRUCTION

© 05/2023

NO.	DATE	REVISIONS	ISSUED FOR BID	ENG.	DATE
A	06/10/2023			VK	

PROJECT NAME: CUMBERLAND ROAD  
69 TO 15 X 25 KV  
SUBSTATION

DRAWING TITLE: LOW SWITCH STAND

DRAWN BY:	DJD
CHECKED BY:	VK
APPROVED BY:	VK
DATE:	05/10/2023
SCALE:	AS SHOWN
FILE NUMBER:	12510
SHEET:	

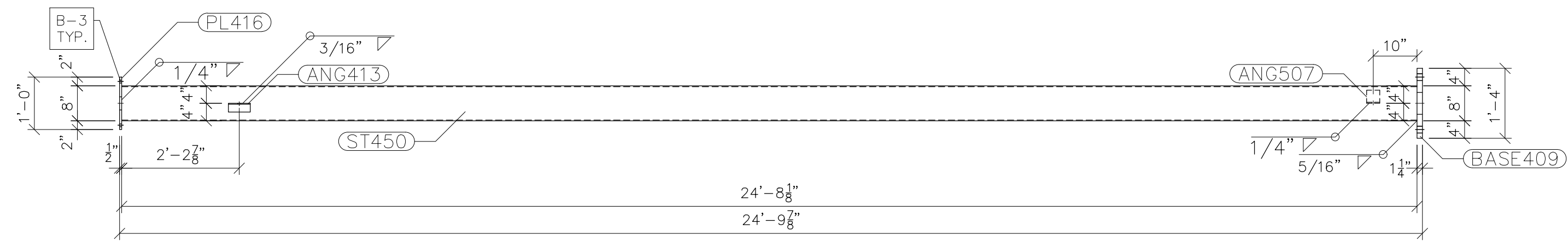

TOP VIEW

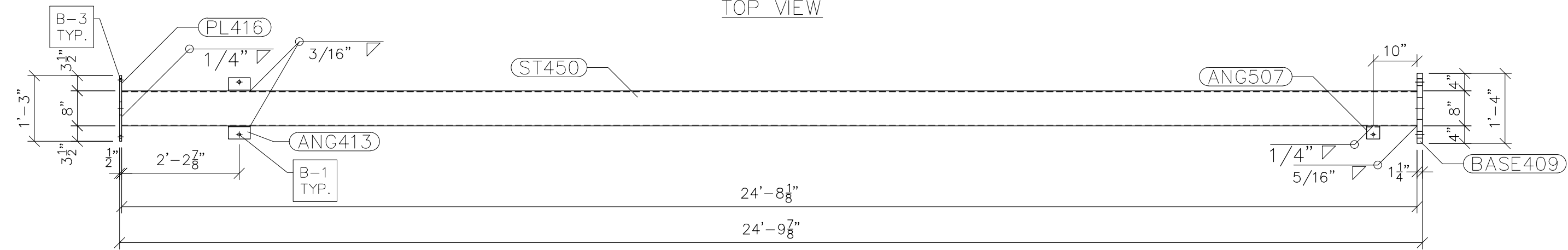

FRONT VIEW

G450  
SCALE: 1/2"=1'-0"

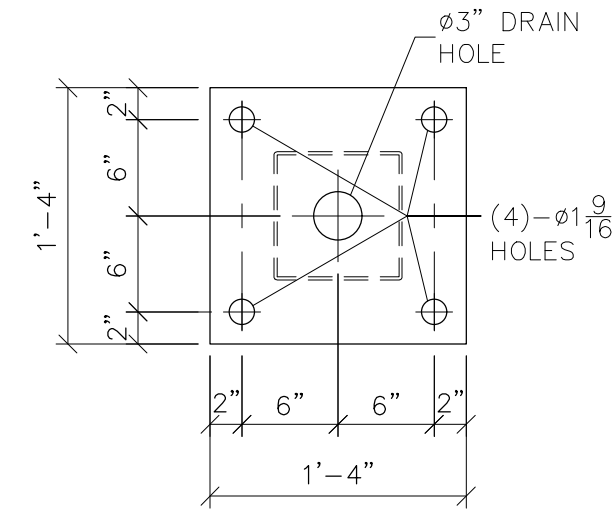

BASE409  
SCALE: 1"=1'-0"

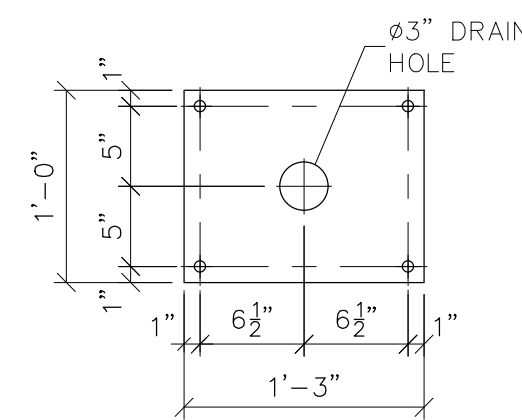

PL416  
SCALE: 1"=1'-0"

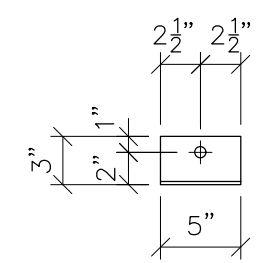

ANG413 FRONT VIEW  
SCALE: 1"=1'-0"

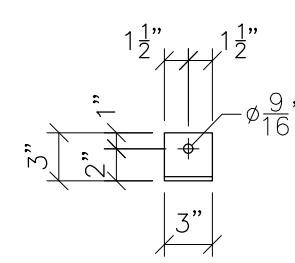

ANG507 FRONT VIEW  
SCALE: 1"=1'-0"

- NOTES:
- 1) ASTM 325 ERECTION BOLTS
  - 2) ALL HOT DIP GALVANIZED AFTER FABRICATION (ASTM A123)
  - 3) ALL HOLES 11/16" DIA. FOR 5/8" DIA. BOLTS UNLESS NOTED
  - 4) PIECE MARK STAMPED INTO METAL WITH NOT LESS THAN 3/8" HIGH CHARACTERS BEFORE GALVANIZING
  - 5) ALL WELDING ELECTRODES SHALL BE E7021
  - 6) EDGE DISTANCE 1" UNLESS NOTED

BILL OF MATERIAL			
POS. NO.	QTY	DESC.	WEIGHT
<b>G450</b>			
ANG413	2	L3x2x3/16	2.56
ANG507	1	L3x3x1/4	1.23
BASE409	1	PL 1 1/4"x1'-4"	90.93
PL416	1	PL 1/2"x1'-0"	25.57
ST450	1	HSS8x8x3/16	484.41
BLACK WEIGHT:			604.70 LBS.
GALVANIZED WEIGHT:			24.19 LBS.
TOTAL WEIGHT:			628.89 LBS.



PRELIMINARY -  
DO NOT USE FOR  
CONSTRUCTION

© 05/2023

NO.	REVISIONS	ENG.	DATE
A	ISSUED FOR BID	VK	06/10/2023

PROJECT NAME: CUMBERLAND ROAD  
69 TO 15 X 25 kV  
SUBSTATION

DRAWING TITLE: HIGH SWITCH STAND

DRAWN BY:	DJD
CHECKED BY:	VK
APPROVED BY:	VK
DATE:	05/10/2023
SCALE:	AS SHOWN
FILE NUMBER:	12510
SHEET:	



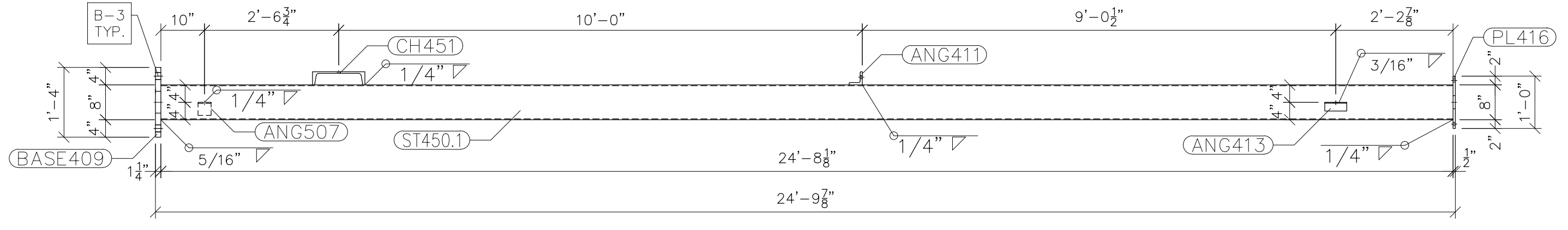

TOP VIEW

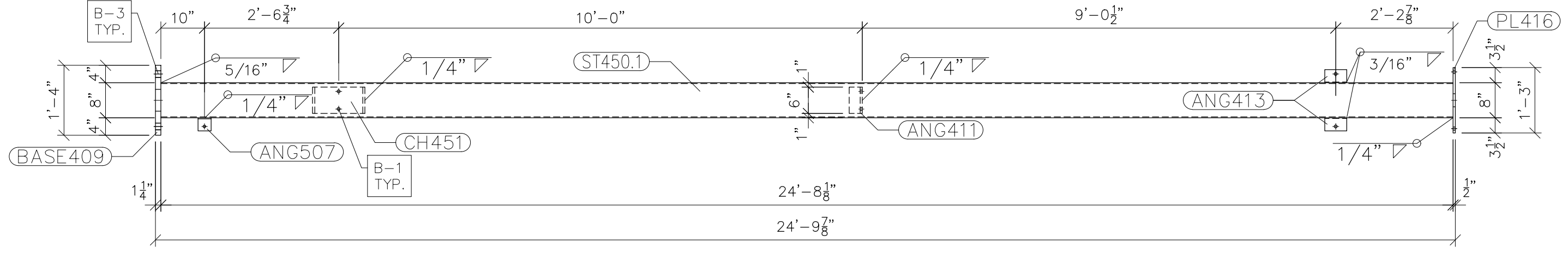

FRONT VIEW

G450.1  
SCALE: 1/2"=1'-0"

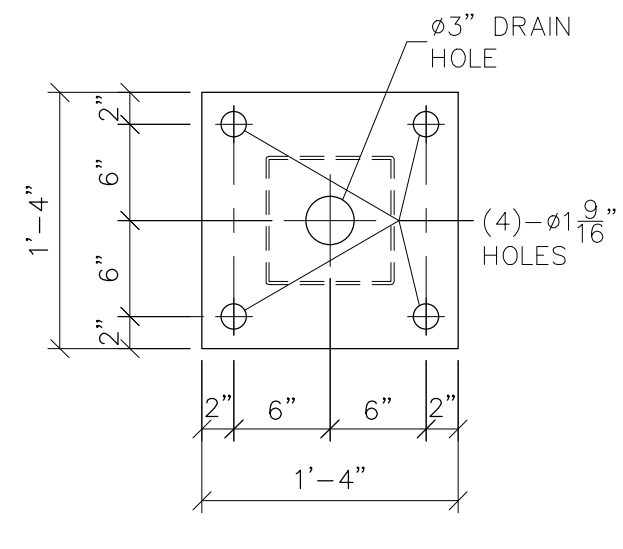

BASE409  
SCALE: 1"=1'-0"

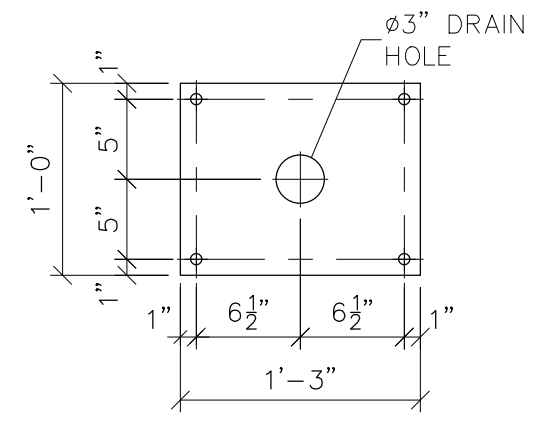

PL416  
SCALE: 1"=1'-0"

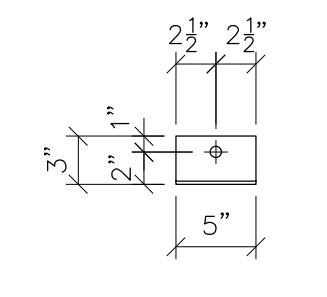

ANG413 FRONT VIEW  
SCALE: 1"=1'-0"

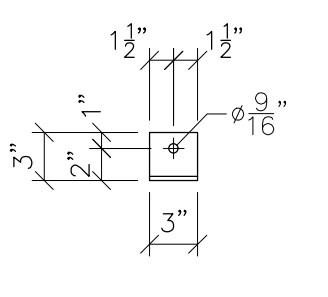

ANG507 FRONT VIEW  
SCALE: 1"=1'-0"

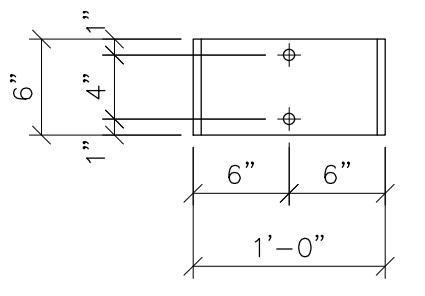

CH451 FRONT VIEW  
SCALE: 1"=1'-0"

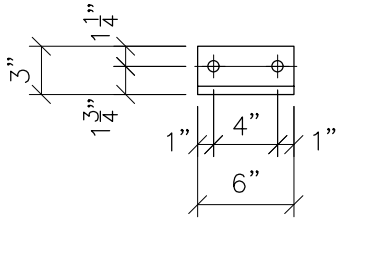

ANG411 FRONT VIEW  
SCALE: 1"=1'-0"

- NOTES:
- 1) ASTM 325 ERECTION BOLTS
  - 2) ALL HOT DIP GALVANIZED AFTER FABRICATION (ASTM A123)
  - 3) ALL HOLES 11/16" DIA. FOR 5/8" DIA. BOLTS UNLESS NOTED
  - 4) PIECE MARK STAMPED INTO METAL WITH NOT LESS THAN 3/8" HIGH CHARACTERS BEFORE GALVANIZING
  - 5) ALL WELDING ELECTRODES SHALL BE E7021
  - 6) EDGE DISTANCE 1" UNLESS NOTED

BILL OF MATERIAL				
POS. NO.	QTY	DESC.	LENGTH	WEIGHT
<b>G450.1</b>	<b>1</b>	<b>FOR ONE GROUP G450.1:</b>		
ANG411	1	L3x3x1/2	6"	4.70
ANG413	2	L3x2x3/16	5"	2.56
ANG507	1	L3x3x1/4	3"	1.23
BASE409	1	PL 1 1/4"x1'-4"	1'-4"	90.93
CH451	1	C12x25	6"	12.50
PL416	1	PL 1/2"x1'-0"	1'-3"	25.57
ST450.1	1	HSS8x8x3/16	24'-8 1/8"	484.41
			BLACK WEIGHT:	621.90 LBS.
			GALVANIZED WEIGHT:	24.88 LBS.
			TOTAL WEIGHT:	646.78 LBS.



Booth & Associates  
2209 Remond Drive Suite 300, Raleigh NC 27607  
NC F 0221



PRELIMINARY -  
DO NOT USE FOR  
CONSTRUCTION

© 05/2023

NO.	REVISIONS	DATE	ENG.	
			WK	CHK
A	ISSUED FOR BID	06/10/2023	VK	

PROJECT NAME: CUMBERLAND ROAD  
69 TO 15 X 25 kV  
SUBSTATION  
DRAWING TITLE: HIGH SWITCH STAND

DRAWN BY:	DJD
CHECKED BY:	VK
APPROVED BY:	VK
DATE:	05/10/2023
SCALE:	AS SHOWN
FILE NUMBER:	12510
SHEET:	

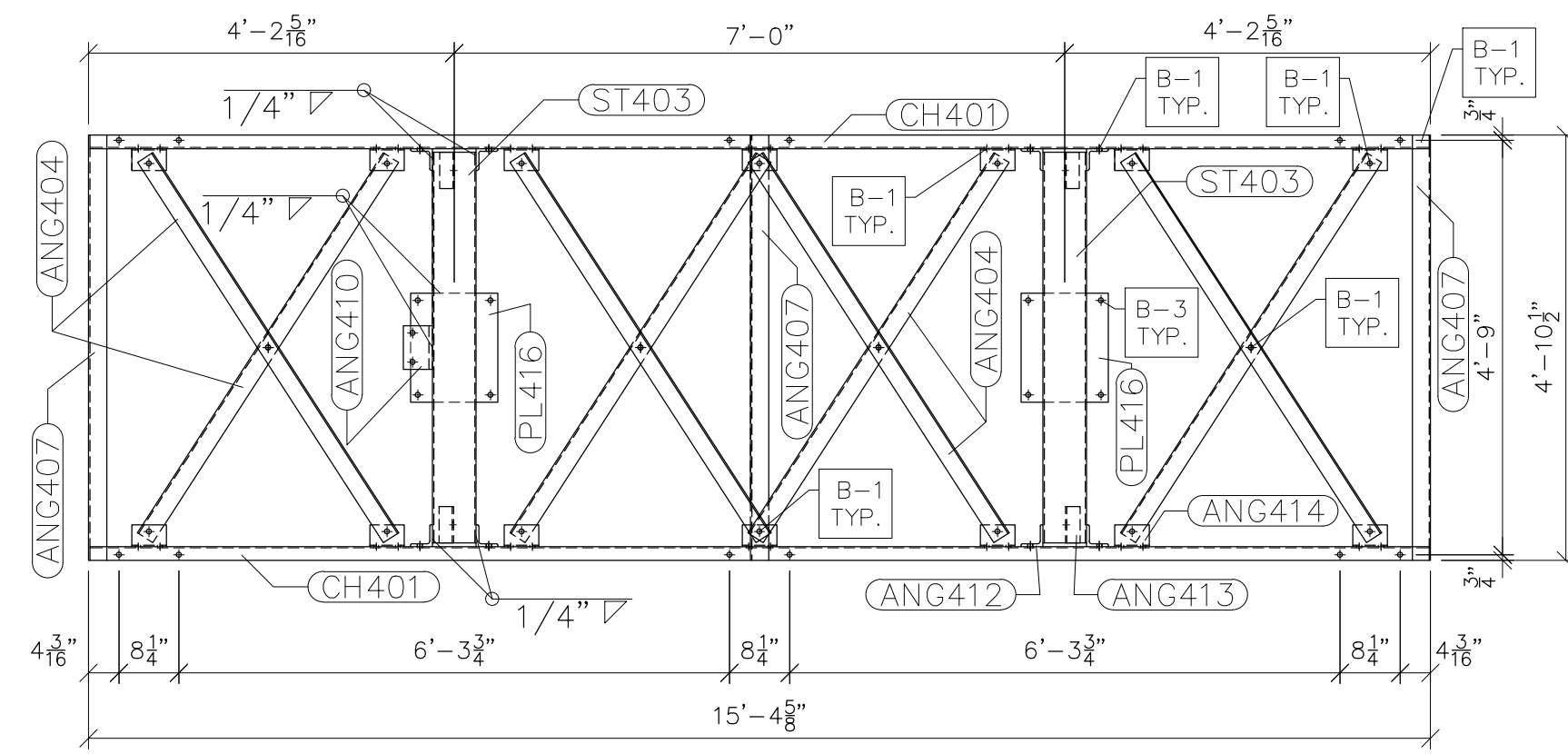

G401 TOP VIEW  
SCALE: 1/2"=1'-0"

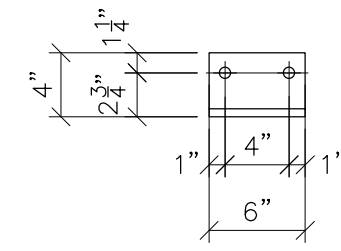

ANG410 FRONT VIEW  
SCALE: 1"=1'-0"

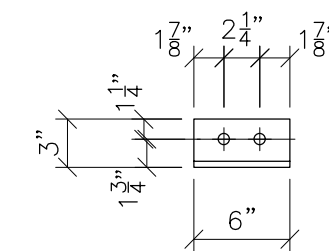

ANG412 FRONT VIEW  
SCALE: 1"=1'-0"

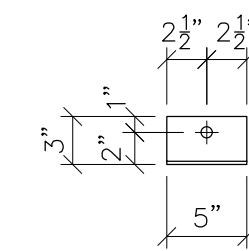

ANG413 FRONT VIEW  
SCALE: 1"=1'-0"

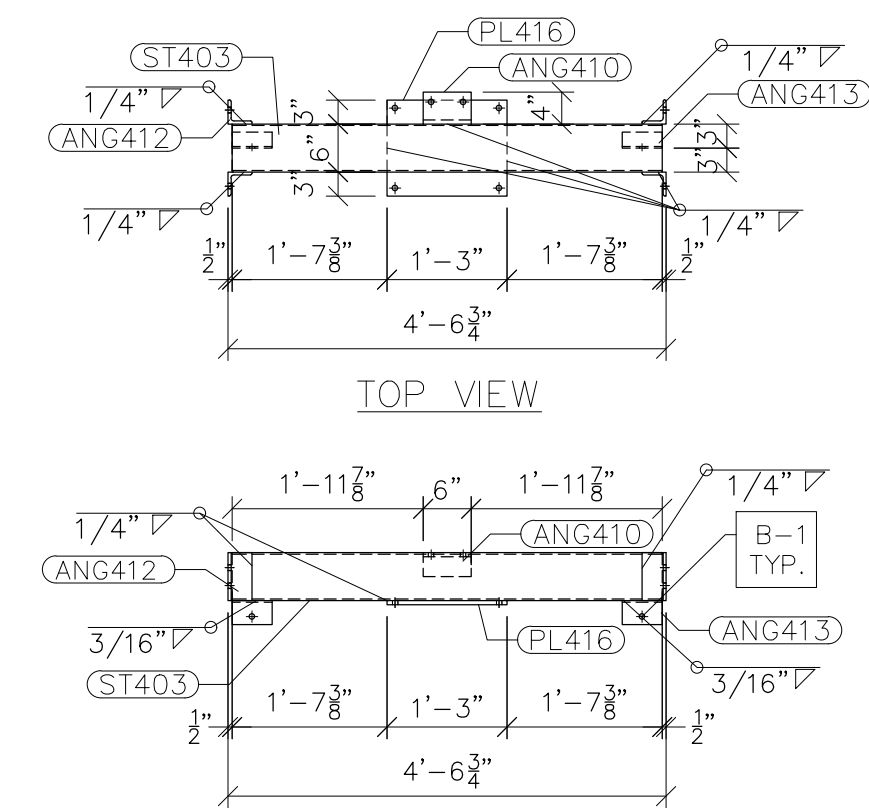

NOTE: ONLY ONE ANG410 NEEDED FOR G401  
SEE G401 TOP VIEW FOR LOCATION  
FRONT VIEW  
G403  
SCALE: 1/2"=1'-0"

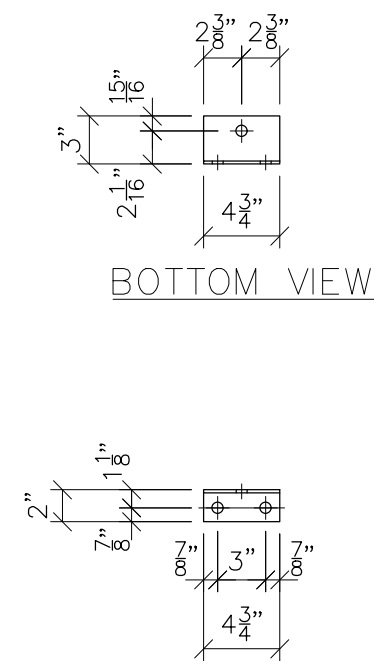

FRONT VIEW  
ANG414  
SCALE: 1"=1'-0"

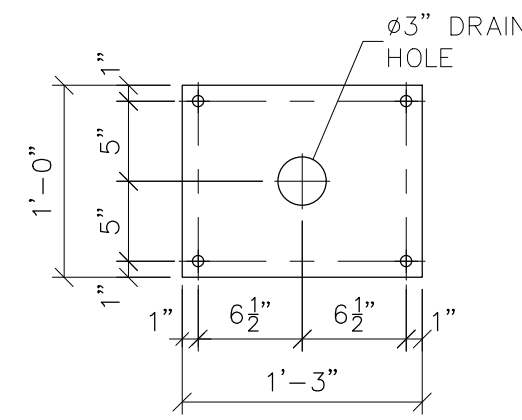

PL416  
SCALE: 1"=1'-0"

- NOTES:  
 1) ASTM 325 ERECTION BOLTS  
 2) ALL HOT DIP GALVANIZED AFTER FABRICATION (ASTM A123)  
 3) ALL HOLES 1/16" DIA. FOR 5/8" DIA. BOLTS UNLESS NOTED  
 4) PIECE MARK STAMPED INTO METAL WITH NOT LESS THAN 3/8" HIGH CHARACTERS BEFORE GALVANIZING  
 5) ALL WELDING ELECTRODES SHALL BE E7021  
 6) EDGE DISTANCE 1" UNLESS NOTED

POS. NO.	QTY	DESC.	LENGTH	WEIGHT
<b>G401</b>				
<b>FOR ONE GROUP G401:</b>				
ANG410	1	L4x3x1/2	6"	5.55
ANG412	8	L3x3x3/8	6"	28.80
ANG413	4	L3x2x3/16	5"	5.12
ANG414	14	L3x2x3/16	4 3/4"	17.01
ST403	2	HSS6x6x3/16	4'-5 3/4"	129.96
PL416	2	PL 1/2"x1'-0"	1'-3"	51.15
CH401	2	C6x8.2	15'-4 1/4"	251.80
ANG404	8	L2 1/2x2 1/2x3/16	5'-2 1/4"	127.44
ANG407	3	L2 1/2x2 1/2x3/16	4'-10 1/2"	44.90
ANG408	4	L2 1/2x2 1/2x3/16	2'-9 11/16"	34.46
BLACK WEIGHT:			696.19	LBS.
GALVANIZED WEIGHT:			27.85	LBS.
TOTAL WEIGHT:			724.04	LBS.

SEE DRAWING No. SS-4 FOR CH401, ANG404, ANG407 & ANG408 DETAILS.



PRELIMINARY -  
DO NOT USE FOR  
CONSTRUCTION

© 05/2023

NO.	ISSUED FOR BID	REVISIONS	ENG.	DATE
A			VK	06/10/2023

PROJECT NAME:  
CUMBERLAND ROAD  
69 TO 15 X 25 kV  
SUBSTATION

DRAWING TITLE:  
SWITCH STAND

DRAWN BY:	DJD
CHECKED BY:	VK
APPROVED BY:	VK
DATE:	05/10/2023
SCALE:	AS SHOWN
FILE NUMBER:	12510
SHEET:	

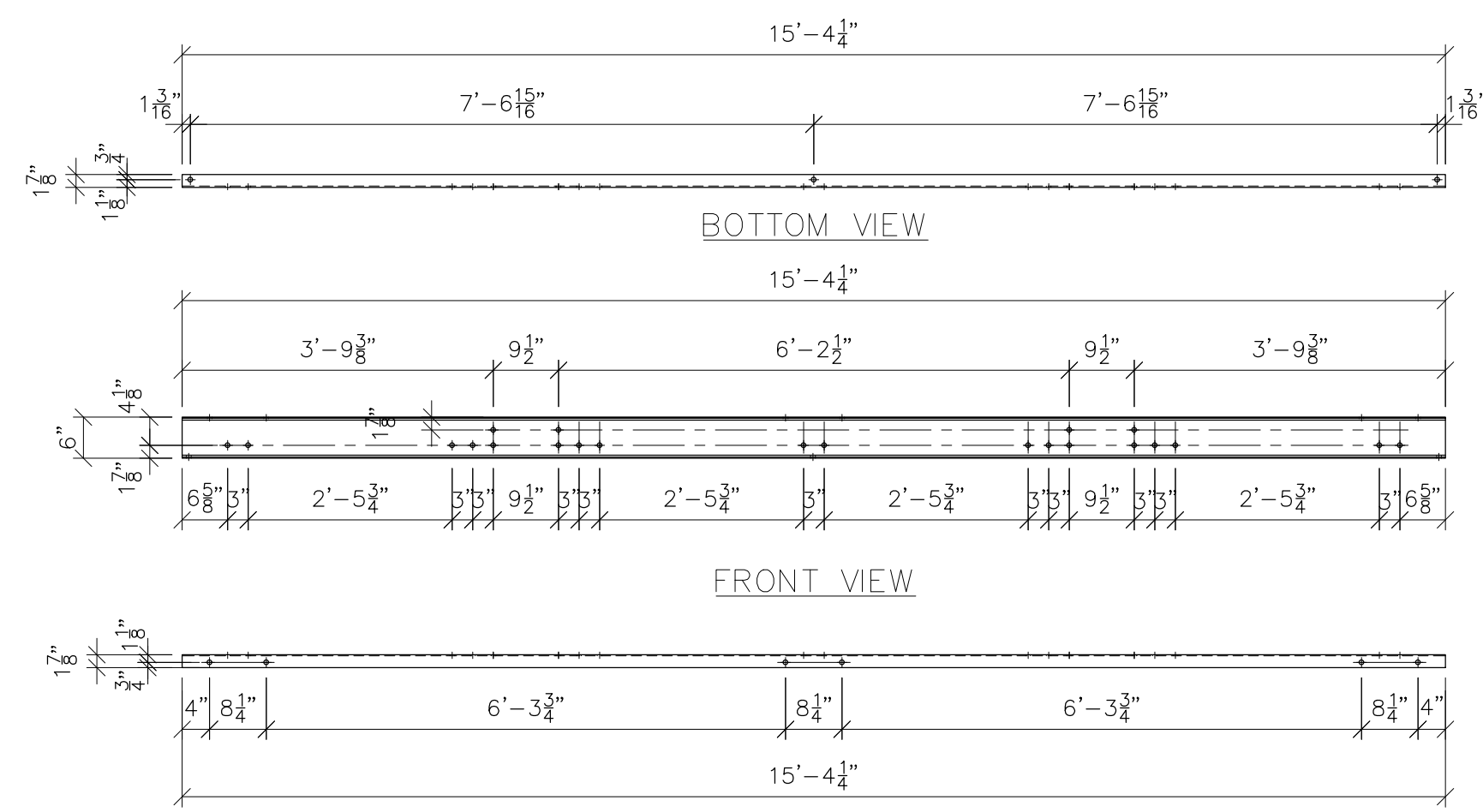

TOP VIEW  
CH401  
SCALE: 1/2"=1'-0"

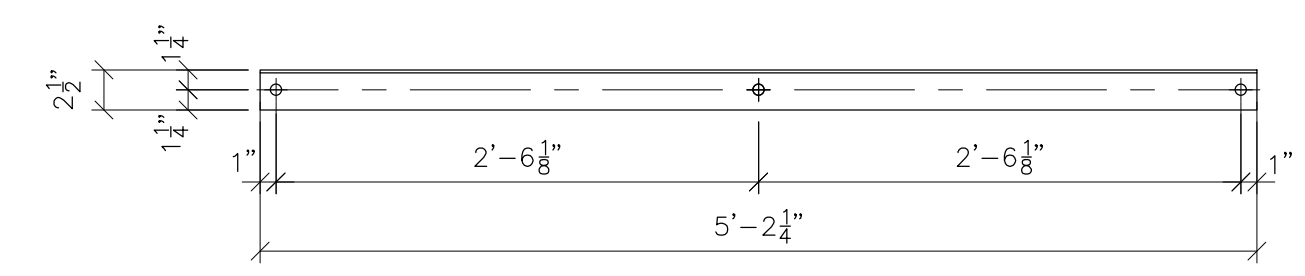

ANG404 FRONT VIEW  
SCALE: 1"=1'-0"

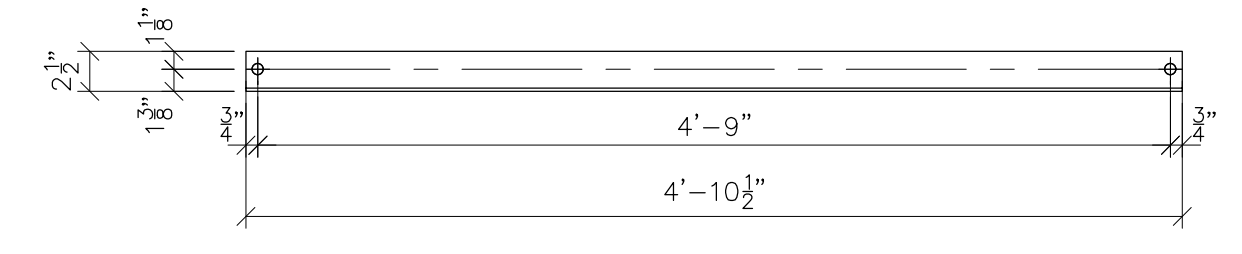

ANG407 FRONT VIEW  
SCALE: 1"=1'-0"

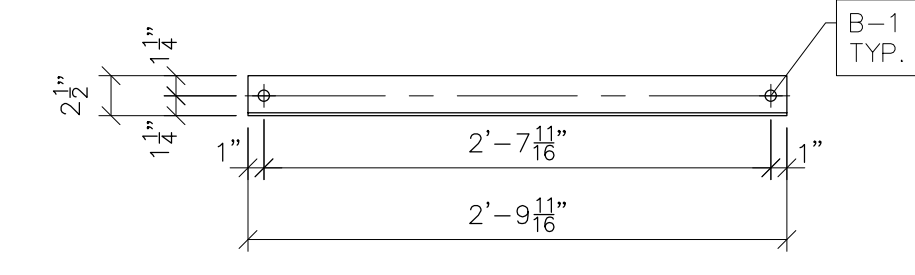

ANG408 FRONT VIEW  
SCALE: 1"=1'-0"

- NOTES:
- 1) ASTM 325 ERECTION BOLTS
  - 2) ALL HOT DIP GALVANIZED AFTER FABRICATION (ASTM A123)
  - 3) ALL HOLES 1 1/16" DIA. FOR 5/8" DIA. BOLTS UNLESS NOTED
  - 4) PIECE MARK STAMPED INTO METAL WITH NOT LESS THAN 3/8" HIGH CHARACTERS BEFORE GALVANIZING
  - 5) ALL WELDING ELECTRODES SHALL BE E7021
  - 6) EDGE DISTANCE 1" UNLESS NOTED



PRELIMINARY -  
DO NOT USE FOR  
CONSTRUCTION

© 05/2023

NO.	ISSUED FOR BID	REVISIONS	ENG.	DATE
A			VK	06/10/2023

PROJECT NAME:	CUMBERLAND ROAD 69 TO 15 X 25 kV SUBSTATION
DRAWING TITLE:	SWITCH STAND
DRAWN BY:	DJD
CHECKED BY:	VK
APPROVED BY:	VK
DATE:	05/10/2023
SCALE:	AS SHOWN
FILE NUMBER:	12510
SHEET:	SS-6

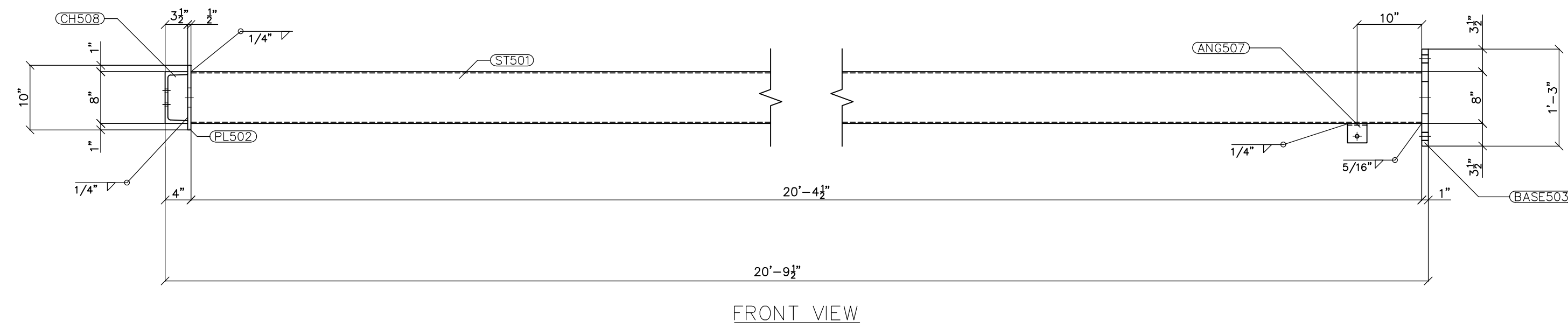
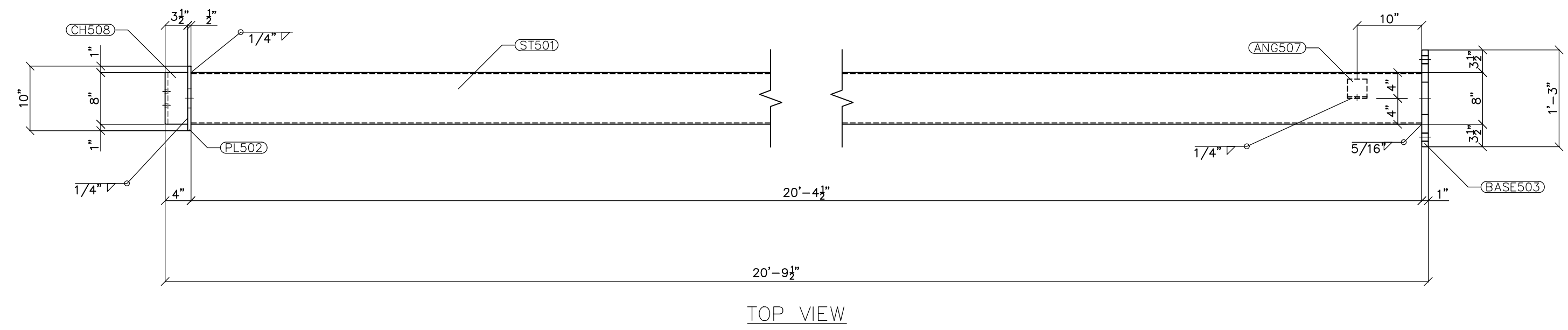

G501  
SCALE: 3/4"=1'-0"

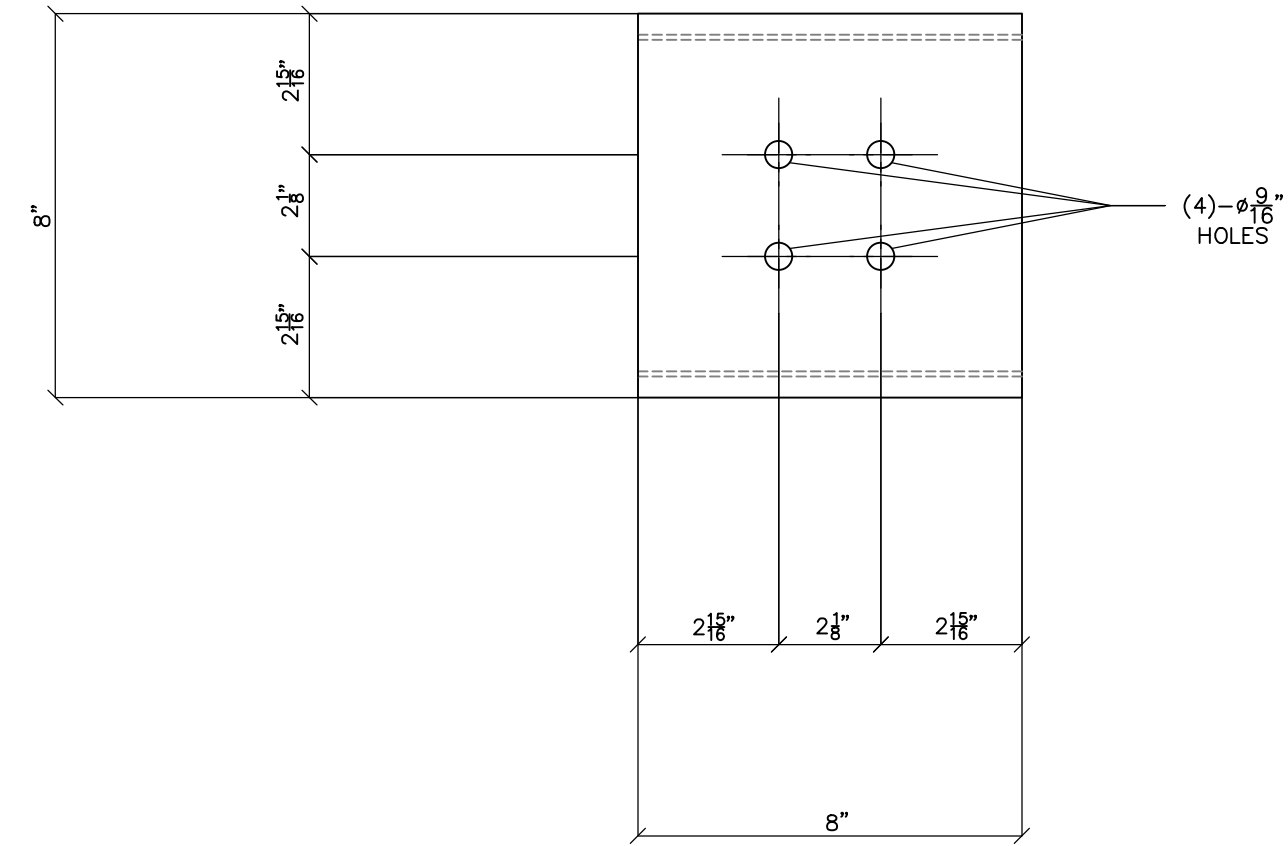

CH508 FRONT VIEW  
SCALE: 3"=1'-0"

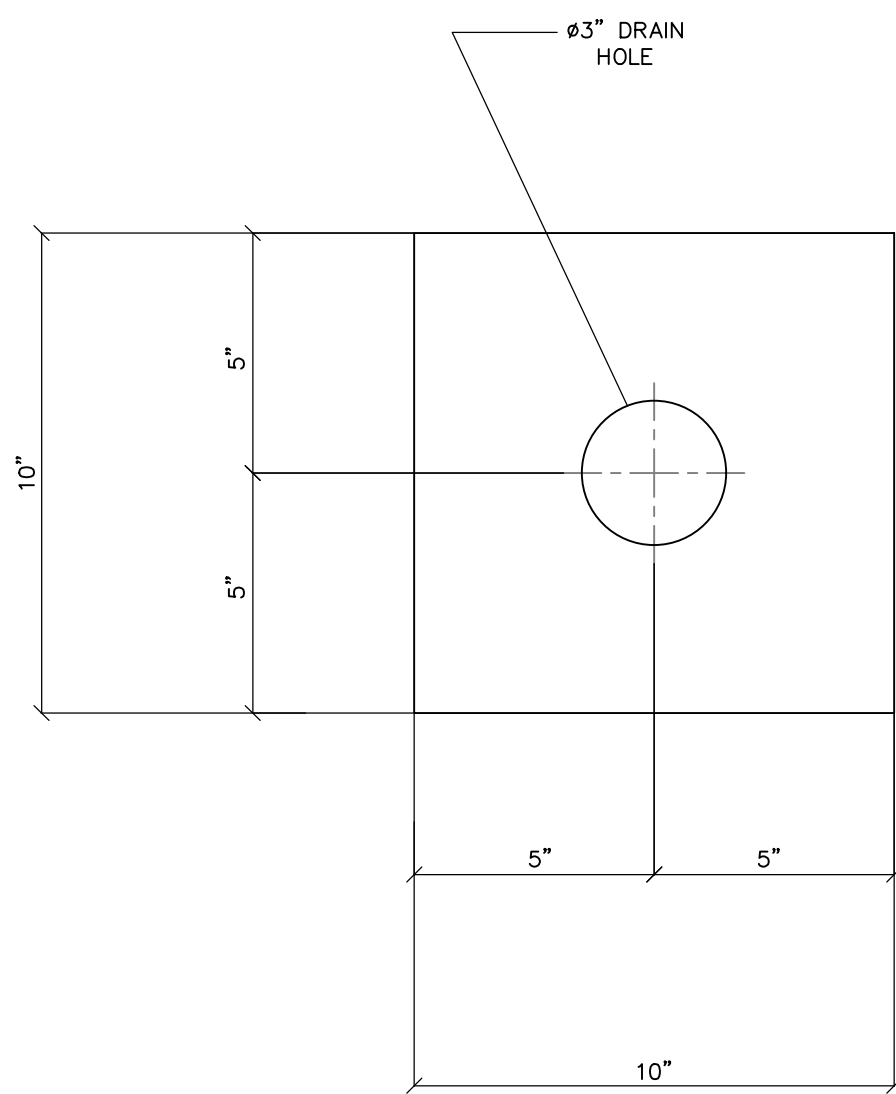

PL502  
SCALE: 3"=1'-0"

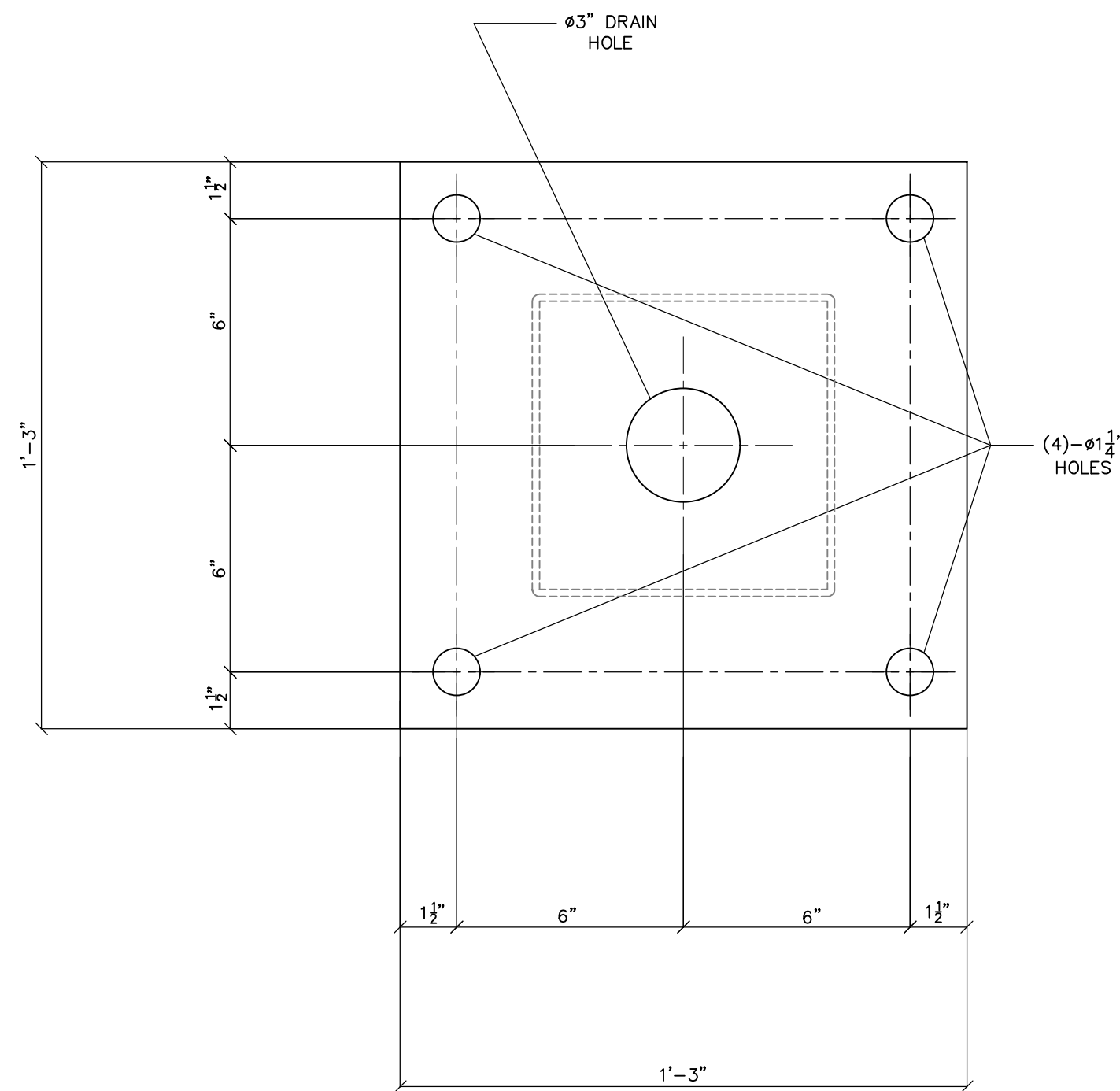

BASE503  
SCALE: 3"=1'-0"

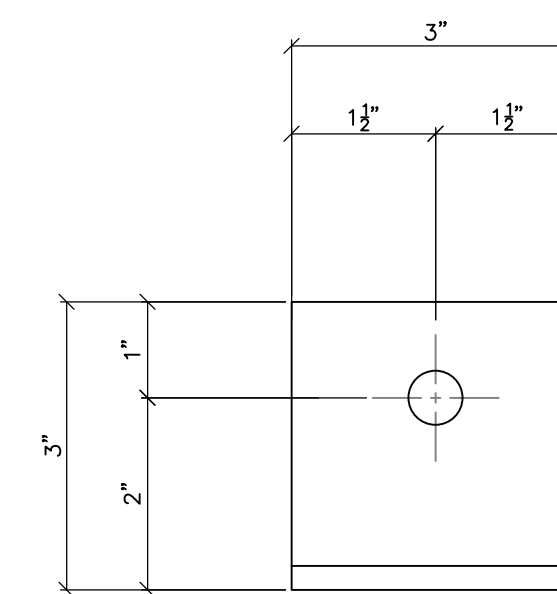

ANG507 FRONT VIEW  
SCALE: 6"=1'-0"

- NOTES:
- 1) ASTM 325 ERECTION BOLTS
  - 2) ALL HOT DIP GALVANIZED AFTER FABRICATION (ASTM A123)
  - 3) ALL HOLES 11/16" DIA. FOR 5/8" DIA. BOLTS UNLESS NOTED
  - 4) PIECE MARK STAMPED INTO METAL WITH NOT LESS THAN 3/8" HIGH CHARACTERS BEFORE GALVANIZING
  - 5) ALL WELDING ELECTRODES SHALL BE E7021
  - 6) EDGE DISTANCE 1" UNLESS NOTED

BILL OF MATERIAL			
POS. NO.	QTY	DESC.	WEIGHT
<b>G501</b>			
ANG507	3	FOR ONE GROUP G501:	
BASE503	1	L3x3x1/4	1.23
CH508	1	Plate 1'-3"x1"	63.93
PL502	1	MCBx22.8	15.20
ST501	1	Pl. 10"x1/2"	14.21
		HSS8x8x3/16	399.55
BLACK WEIGHT:			494.12 LBS.
GALVANIZED WEIGHT:			19.76 LBS.
TOTAL WEIGHT:			513.88 LBS.



PRELIMINARY -  
DO NOT USE FOR  
CONSTRUCTION

© 05/2023

NO.	ISSUED FOR BID	REVISIONS	ENG.	DATE
A			VK	06/10/2023

PROJECT NAME: CUMBERLAND ROAD  
69 TO 15 X 25 KV  
SUBSTATION

DRAWING TITLE:  
1Ø BUS STAND

DRAWN BY:	DJD
CHECKED BY:	VK
APPROVED BY:	VK
DATE:	05/10/2023
SCALE:	AS SHOWN
FILE NUMBER:	12510
SHEET:	

BUS-1

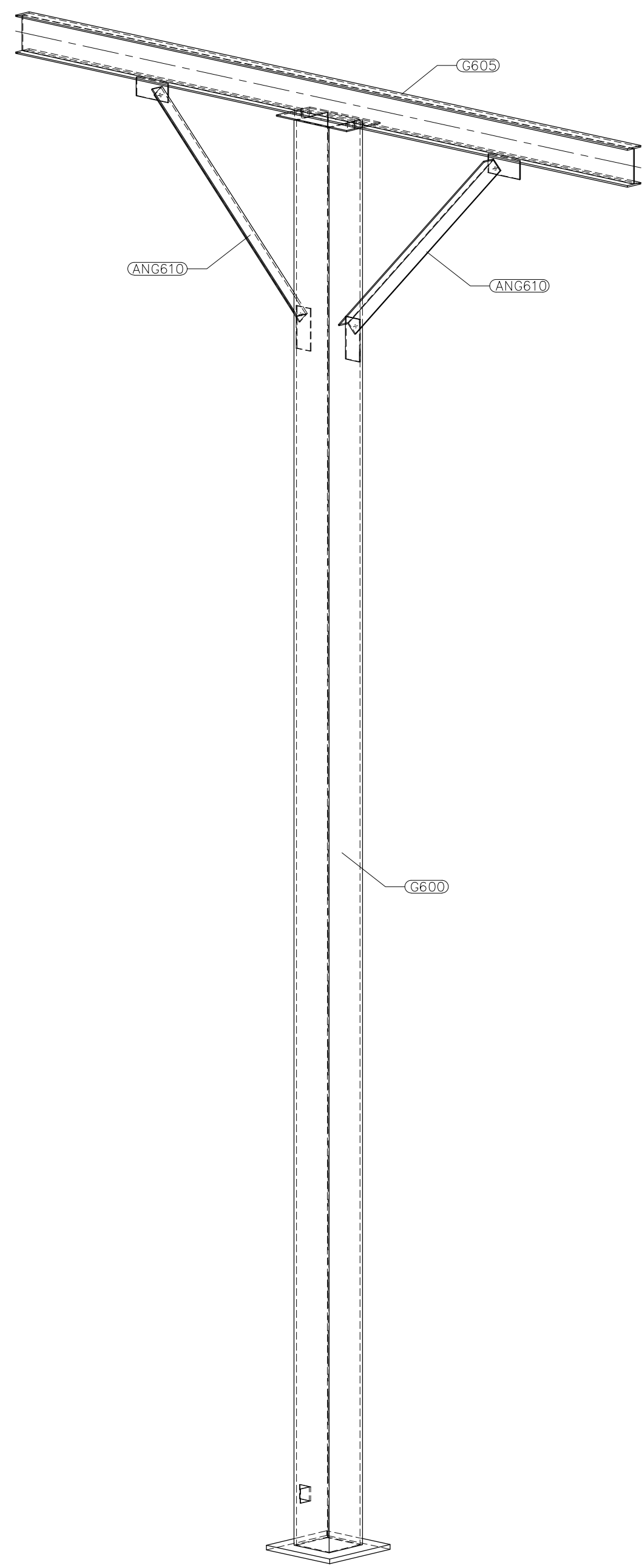

ISOMETRIC VIEW  
SCALE: N.T.S.

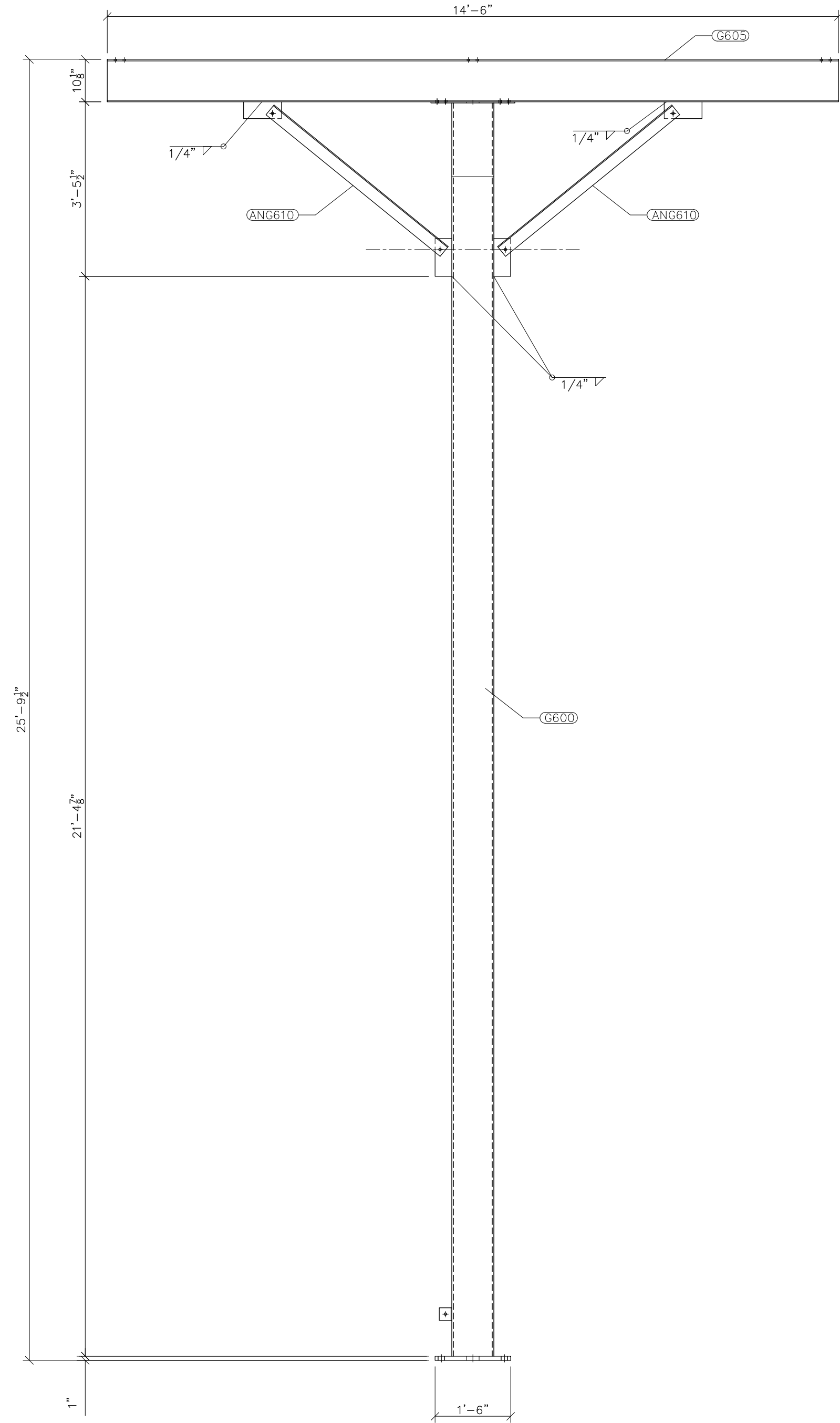

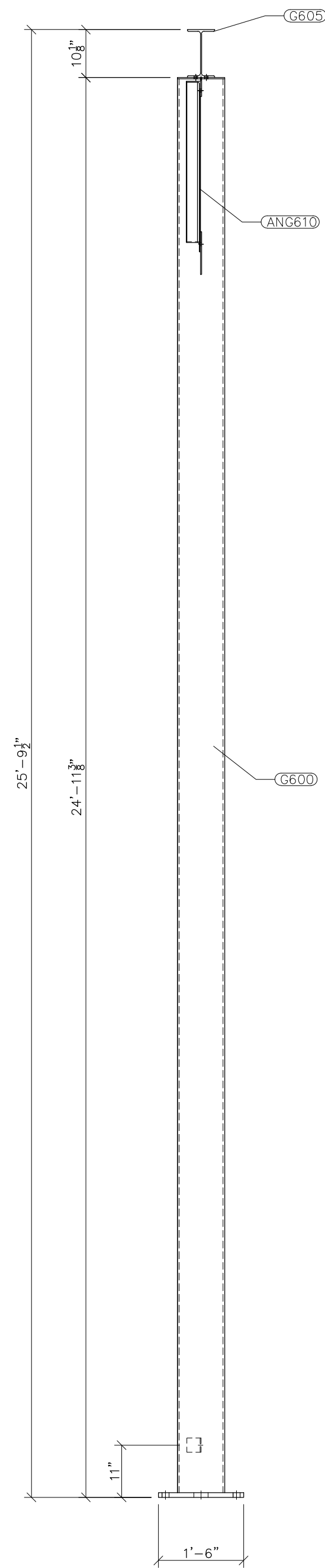

FRONT VIEW  
SCALE: 1/2"=1'-0"

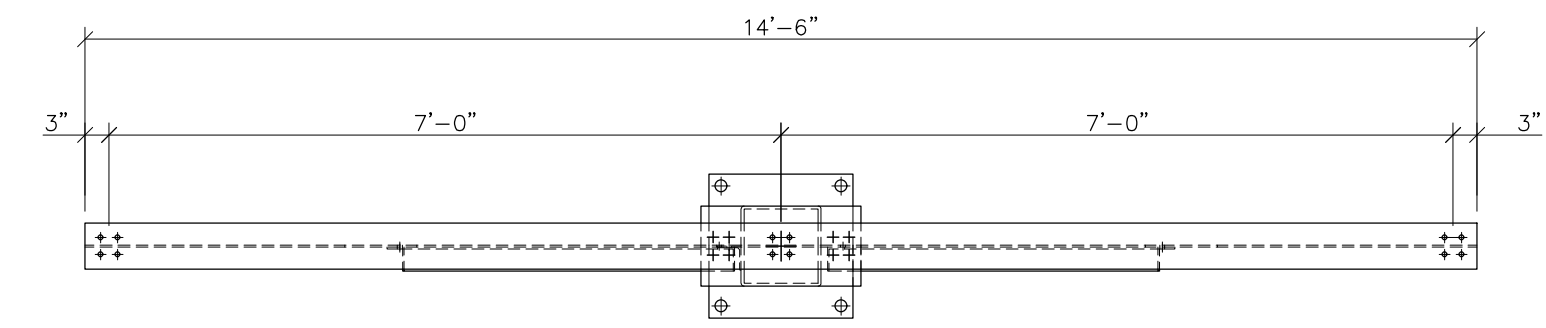

SIDE VIEW  
SCALE: 1/2"=1'-0"



TOP VIEW  
SCALE: 1/2"=1'-0"

  
  
**Booth & Associates**  
2300 Rowwood Drive Suite 300, Raleigh, NC 27607  
N.C.F. 0221

PRELIMINARY -  
 DO NOT USE FOR  
 CONSTRUCTION

© 05/2023

NO.	ISSUED FOR BID	REVISIONS	ENG.	DATE
A			VK	06/10/2023

PROJECT NAME: CUMBERLAND ROAD  
 69 TO 15 X 25 kV  
 SUBSTATION  
 DRAWING TITLE: 30 BUS STAND

DRAWN BY:	DJD
CHECKED BY:	VK
APPROVED BY:	VK
DATE:	05/10/2023
SCALE:	AS SHOWN
FILE NUMBER:	12510
SHEET:	

TPB-1

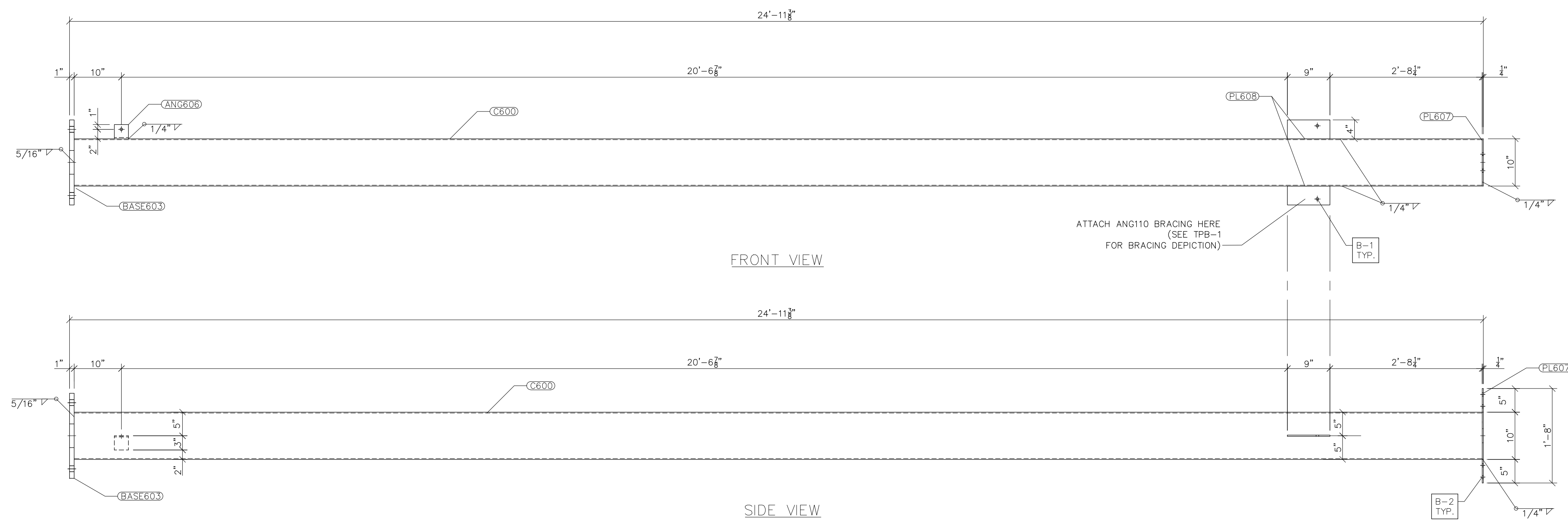

FRONT VIEW

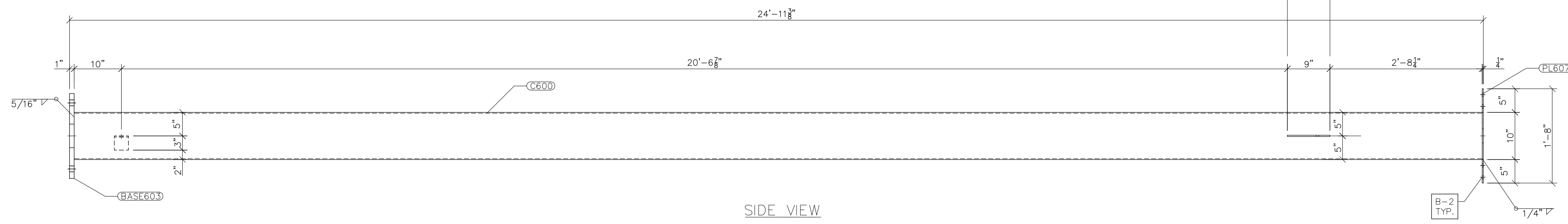

SIDE VIEW

G600  
SCALE: 3/4"=1'-0"

- NOTES:
- 1) ASTM 325 ERECTION BOLTS
  - 2) ALL HOT DIP GALVANIZED AFTER FABRICATION (ASTM A123)
  - 3) ALL HOLES 11/16" DIA. FOR 5/8" DIA. BOLTS UNLESS NOTED
  - 4) PIECE MARK STAMPED INTO METAL WITH NOT LESS THAN 3/8" HIGH CHARACTERS BEFORE GALVANIZING
  - 5) ALL WELDING ELECTRODES SHALL BE E7021
  - 6) EDGE DISTANCE 1" UNLESS NOTED

BILL OF MATERIAL					
POS. NO.	QTY	DESC.	LENGTH	WEIGHT	
G600	1	FOR ONE GROUP G600:			
C600	1	HSS10x10x3/8	24'-10 1/8"	1188.09	
BASE603	1	PL 1"x 1'-6"	1'-6"	91.88	
PL607	1	PL 1/4"x10"	1'-8"	14.18	
PL608	2	PL 1/4"x4"	9"	5.10	
ANG606	1	L3x3x1/4	3"	1.23	
ANG610	2	L3x3x1/4	4'-5 3/8"	43.59	
BLACK WEIGHT:			1344.07 LBS.		
GALVANIZED WEIGHT:			53.76 LBS.		
TOTAL WEIGHT:			1397.83 LBS.		

SEE TPB-1 FOR GROUP G600 LOCATION

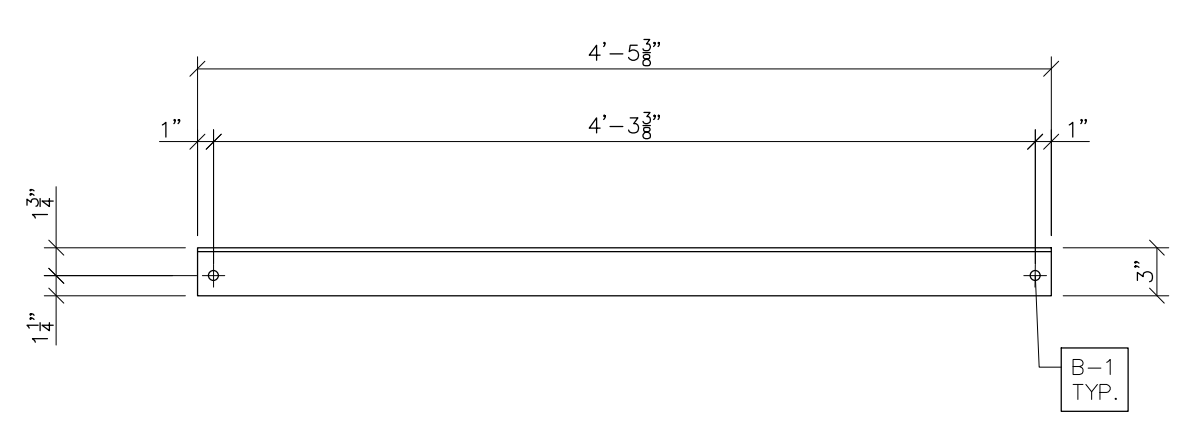

ANG610 FRONT VIEW  
SCALE: 1"=1'-0"

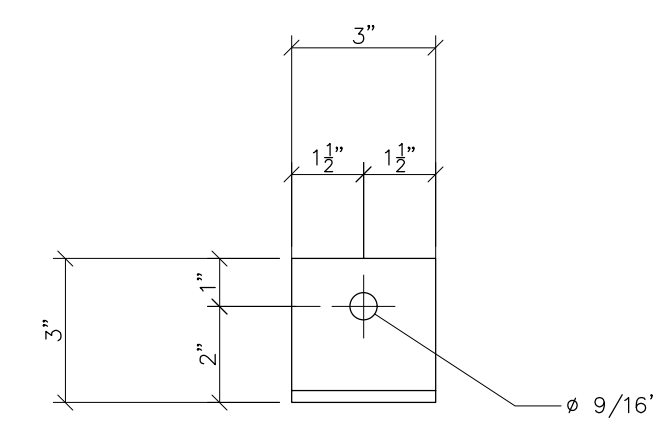

ANG606 FRONT VIEW  
SCALE: N.T.S.

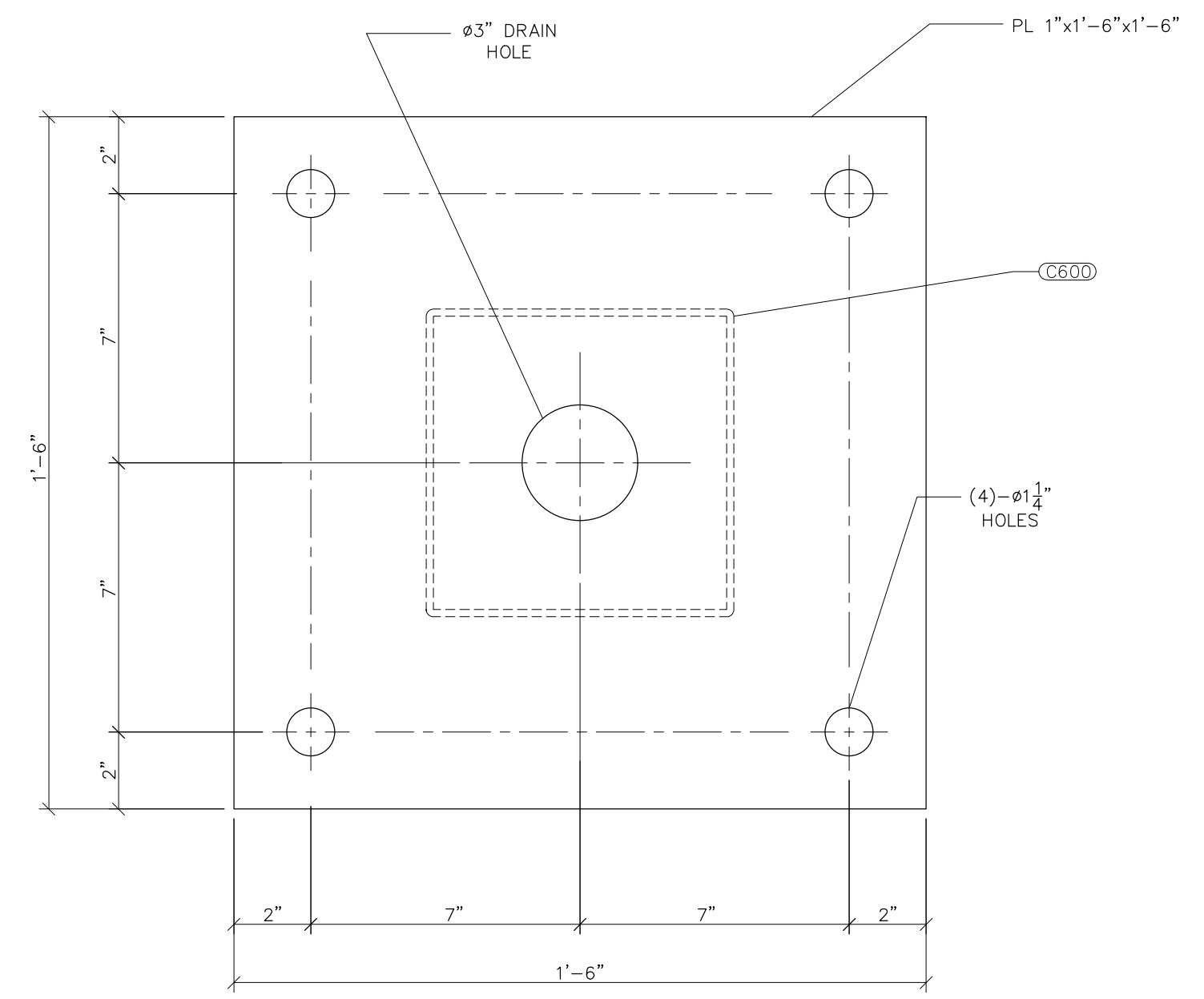

BASE603  
SCALE: 3/4"=1'-0"

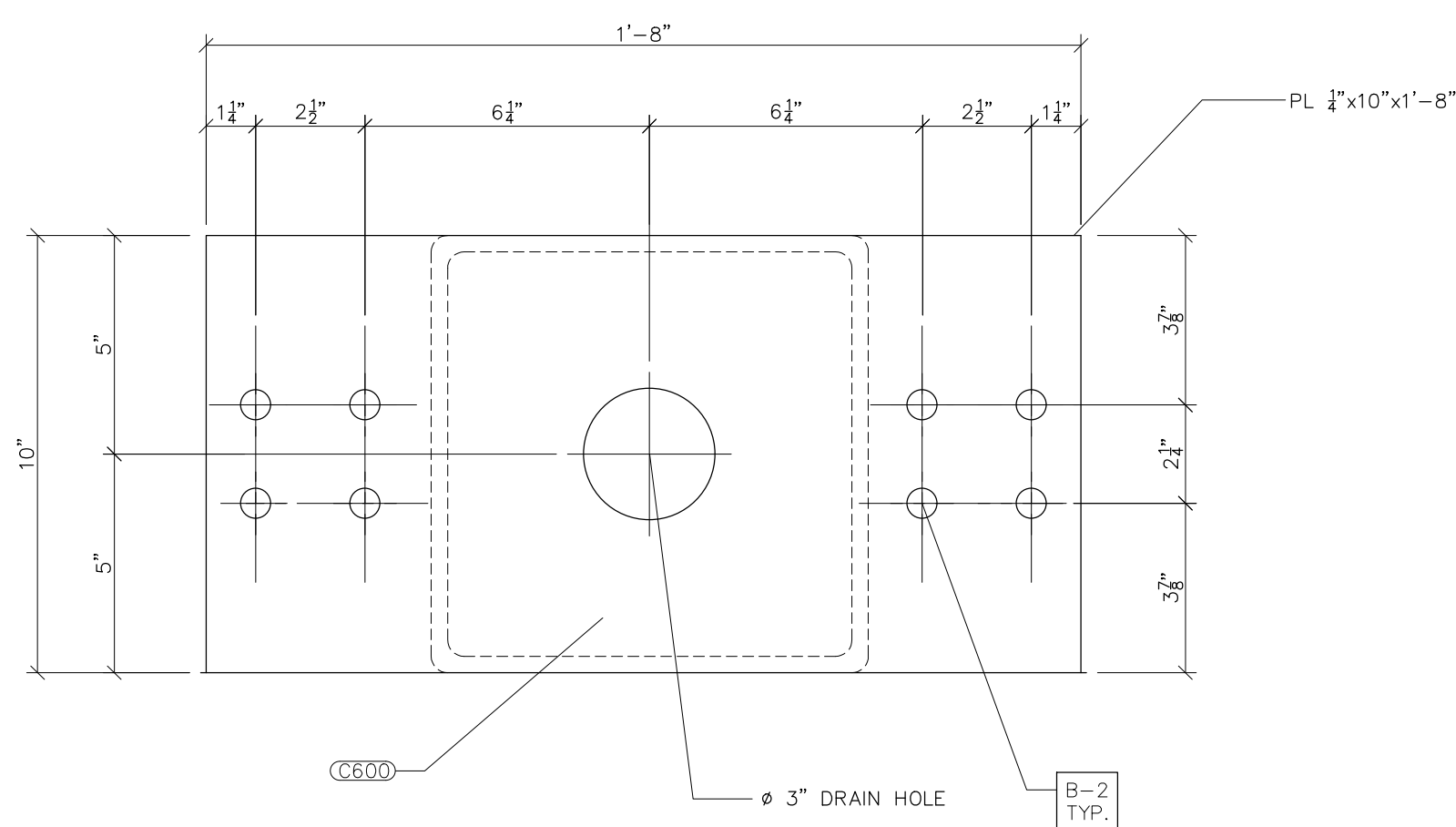

PL607  
SCALE: 3/4"=1'-0"

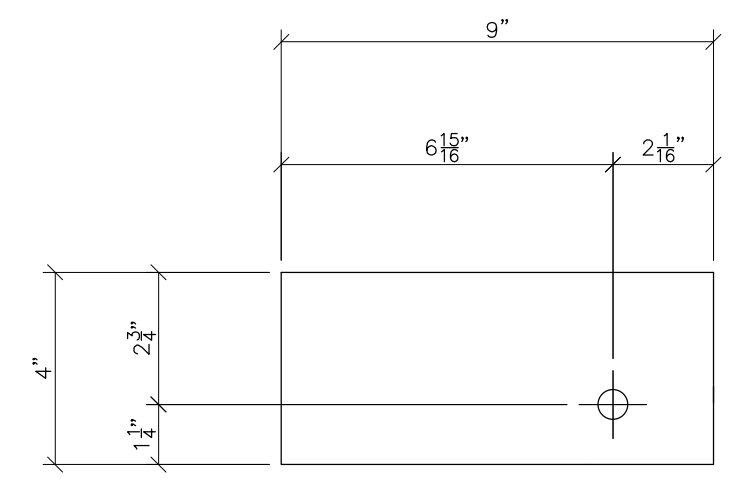

PL608 FRONT VIEW  
SCALE: N.T.S.



PRELIMINARY -  
DO NOT USE FOR  
CONSTRUCTION

© 05/2023

NO.	ISSUED FOR BID	REVISIONS	ENG.	DATE
A			VK	06/10/2023

PROJECT NAME: CUMBERLAND ROAD  
69 TO 15 X 25 kV  
SUBSTATION

DRAWING TITLE: 3Ø BUS STAND

DRAWN BY:	DJD
CHECKED BY:	VK
APPROVED BY:	VK
DATE:	05/10/2023
SCALE:	AS SHOWN
FILE NUMBER:	12510
SHEET:	

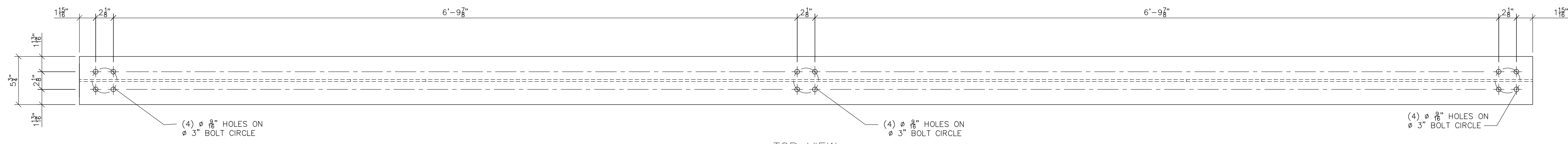

TOP VIEW

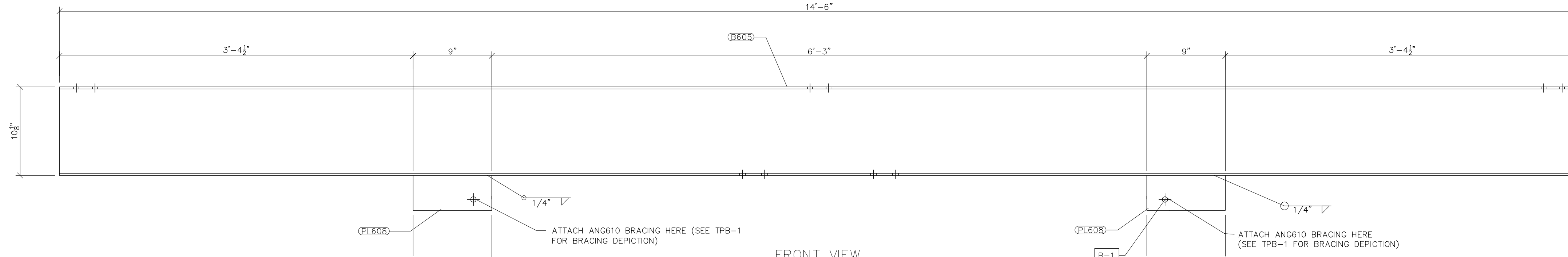

FRONT VIEW

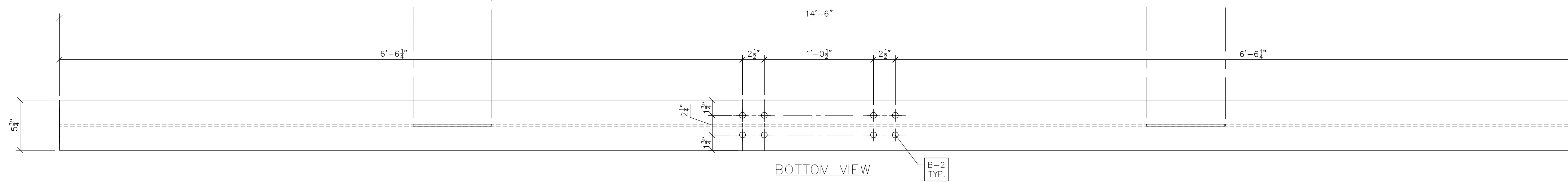

BOTTOM VIEW

G605  
SCALE: 1-1/2"=1'-0"

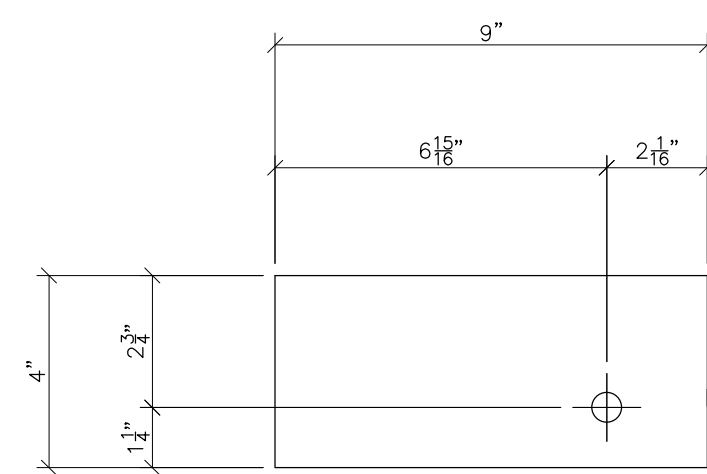

PL608 FRONT VIEW  
SCALE: N.T.S.

- NOTES:
- 1) ASTM 325 ERECTION BOLTS
  - 2) ALL HOT DIP GALVANIZED AFTER FABRICATION (ASTM A123)
  - 3) ALL HOLES 11/16" DIA. FOR 5/8" DIA. BOLTS UNLESS NOTED
  - 4) PIECE MARK STAMPED INTO METAL WITH NOT LESS THAN 3/8" HIGH CHARACTERS BEFORE GALVANIZING
  - 5) ALL WELDING ELECTRODES SHALL BE E7021
  - 6) EDGE DISTANCE 1" UNLESS NOTED

BILL OF MATERIAL				
POS. NO.	QTY	DESC.	LENGTH	WEIGHT
<b>G605</b>	<b>1</b>	<b>FOR ONE GROUP G605:</b>		
B605	1	W10x22	14'-6"	319.00
PL608	2	PL 1/4"x4"	9"	5.10
BLACK WEIGHT:			324.10	LBS.
GALVANIZED WEIGHT:			12.96	LBS.
TOTAL WEIGHT:			337.06	LBS.

SEE TPB-1 FOR GROUP G605 AND BRACING LOCATIONS



PRELIMINARY -  
DO NOT USE FOR  
CONSTRUCTION

© 05/2023

NO.	ISSUED FOR BID	REVISIONS	ENG.	DATE
A			VK	06/10/2023

PROJECT NAME: CUMBERLAND ROAD  
69 TO 15 X 25 kV  
SUBSTATION

DRAWING TITLE: 3Ø BUS STAND

DRAWN BY:	DJD
CHECKED BY:	VK
APPROVED BY:	VK
DATE:	05/10/2023
SCALE:	AS SHOWN
FILE NUMBER:	12510
SHEET:	

- NOTES:
- 1) ASTM 325 ERECTION BOLTS
  - 2) ALL HOT DIP GALVANIZED AFTER FABRICATION (ASTM A123)
  - 3) ALL HOLES 11/16" DIA. FOR 5/8" DIA. BOLTS UNLESS NOTED
  - 4) PIECE MARK STAMPED INTO METAL WITH NOT LESS THAN 3/8" HIGH CHARACTERS BEFORE GALVANIZING
  - 5) ALL WELDING ELECTRODES SHALL BE E7021
  - 6) EDGE DISTANCE 1" UNLESS NOTED

BILL OF MATERIAL				
POS. NO.	QTY	DESC.	LENGTH	WEIGHT
<b>GM-1</b>	<b>10</b>	<b>FOR ONE GROUNDING MAT:</b>		
R1	2	3'x3/4"x3/16" (19W4 GRATING)	4'-0"	134.0
SA1	8	L3"x3"x3/16"	3"	7.4
SA2	4	L1-3/4"x1-3/4"x3/16"	3'-0"	26.0
SP1	4	PL 2x1/4"	3"	2.0
BLACK WEIGHT:				169.4 LBS.
GALVANIZED WEIGHT:				6.8 LBS.
TOTAL WEIGHT:				176.2 LBS.

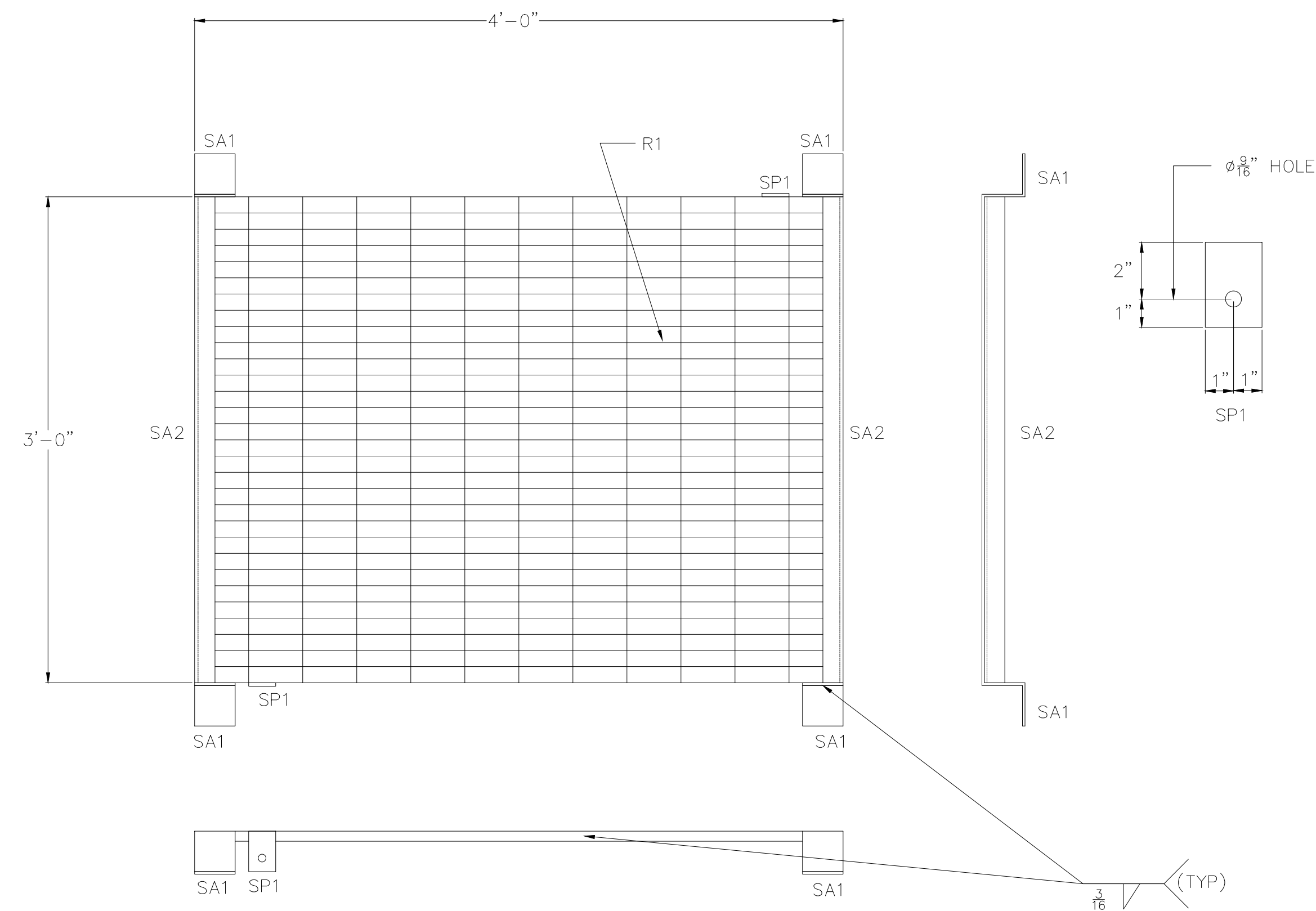

GROUND MAT - GM34  
(TWO REQUIRED)  
SCALE: 1-1/2"=1'-0"

PRELIMINARY -  
DO NOT USE FOR  
CONSTRUCTION

© 05/2023

NO.	ISSUED FOR BID	REVISIONS	ENG.	DATE
A			VK	06/10/2023

PROJECT NAME: CUMBERLAND ROAD  
69 TO 15 X 25 KV  
SUBSTATION

DRAWING TITLE:  
GROUNDING MAT DETAILS

DRAWN BY:	DJD
CHECKED BY:	VK
APPROVED BY:	VK
DATE:	05/10/2023
SCALE:	AS SHOWN
FILE NUMBER:	12510
SHEET:	

GM-1



**ERECTION BOLT SUMMARY FOR LOWSIDE**

BOLT NUMBER	ASTM A325-N BOLTS	BOLT TYPE	QUANTITY
B-1	5/8" DIAMETER x 1 3/4" H.S.G.B. W/(1)FW + (1)HHN	FIELD	294
B-2	5/8" DIAMETER x 2" H.S.G.B. W/(1)FW + (1)HHN	FIELD	308
B-4	5/8" DIAMETER x 2 1/2" H.S.G.B. W/(1)FW + (1)HHN	FIELD	40
B-5	5/8" DIAMETER x 2 3/4" H.S.G.B. W/(1)FW + (1)HHN	FIELD	48

**ERECTION BOLT SUMMARY FOR URD STAND**

BOLT NUMBER	ASTM A325-N BOLTS	BOLT TYPE	QUANTITY
B-1	5/8" DIAMETER x 1 3/4" H.S.G.B. W/(1)FW + (1)HHN	FIELD	96
B-2	5/8" DIAMETER x 2" H.S.G.B. W/(1)FW + (1)HHN	FIELD	192

**ERECTION BOLT SUMMARY FOR A-FRAME**

BOLT NUMBER	ASTM A325-N BOLTS	BOLT TYPE	QUANTITY
B-1	5/8" DIAMETER x 1 3/4" H.S.G.B. W/(1)FW + (1)HHN	FIELD	195
B-2	5/8" DIAMETER x 2" H.S.G.B. W/(1)FW + (1)HHN	FIELD	48
B-3	5/8" DIAMETER x 2 1/4" H.S.G.B. W/(1)FW + (1)HHN	FIELD	68
B-4	5/8" DIAMETER x 2 1/2" H.S.G.B. W/(1)FW + (1)HHN	FIELD	12
B-5	5/8" DIAMETER x 2 3/4" H.S.G.B. W/(1)FW + (1)HHN	FIELD	36
B-6	5/8" DIAMETER x 3 1/2" H.S.G.B. W/(1)FW + (1)HHN	FIELD	36

**ERECTION BOLT SUMMARY FOR LOW SWITCH STAND**

BOLT NUMBER	ASTM A325-N BOLTS	BOLT TYPE	QUANTITY
B-1	5/8" DIAMETER x 1 3/4" H.S.G.B. W/(1)FW + (1)HHN	FIELD	70
B-3	5/8" DIAMETER x 2 1/4" H.S.G.B. W/(1)FW + (1)HHN	FIELD	8

**ERECTION BOLT SUMMARY FOR HIGH SWITCH STAND**

BOLT NUMBER	ASTM A325-N BOLTS	BOLT TYPE	QUANTITY
B-1	5/8" DIAMETER x 1 3/4" H.S.G.B. W/(1)FW + (1)HHN	FIELD	70
B-3	5/8" DIAMETER x 2 1/4" H.S.G.B. W/(1)FW + (1)HHN	FIELD	8

**ERECTION BOLT SUMMARY FOR THREE PHASE BUS STAND**

BOLT NUMBER	ASTM A325-N BOLTS	BOLT TYPE	QUANTITY
B-1	5/8" DIAMETER x 1 3/4" H.S.G.B. W/(1)FW + (1)HHN	FIELD	4
B-2	5/8" DIAMETER x 2" H.S.G.B. W/(1)FW + (1)HHN	FIELD	8

**ERECTION BOLT SUMMARY FOR STATIC POLE**

BOLT NUMBER	ASTM A325-N BOLTS	BOLT TYPE	QUANTITY
B-7	1" DIAMETER x 2 3/4" H.S.G.B. W/(1)FW + (1)HHN	FIELD	4

**ERECTION BOLT TOTAL SUMMARY**

BOLT NUMBER	ASTM A325-N BOLTS	BOLT TYPE	QUANTITY
B-1	5/8" DIAMETER x 1 3/4" H.S.G.B. W/(1)FW + (1)HHN	FIELD	729
B-2	5/8" DIAMETER x 2" H.S.G.B. W/(1)FW + (1)HHN	FIELD	556
B-3	5/8" DIAMETER x 2 1/4" H.S.G.B. W/(1)FW + (1)HHN	FIELD	84
B-4	5/8" DIAMETER x 2 1/2" H.S.G.B. W/(1)FW + (1)HHN	FIELD	52
B-5	5/8" DIAMETER x 2 3/4" H.S.G.B. W/(1)FW + (1)HHN	FIELD	84
B-6	5/8" DIAMETER x 3 1/2" H.S.G.B. W/(1)FW + (1)HHN	FIELD	36
B-7	1" DIAMETER x 2 3/4" H.S.G.B. W/(1)FW + (1)HHN	FIELD	4



**PRELIMINARY -  
DO NOT USE FOR  
CONSTRUCTION**

© 05/2023

NO.	A	ISSUED FOR BID	REVISIONS	ENG.	DATE
				VK	06/10/2023

PROJECT NAME: CUMBERLAND ROAD  
69 TO 15 X 25 KV  
SUBSTATION

DRAWING TITLE: BOLT SCHEDULE

DRAWN BY:	DJD
CHECKED BY:	VK
APPROVED BY:	VK
DATE:	05/10/2023
SCALE:	N.T.S.
FILE NUMBER:	12510
SHEET:	

**BOLT SCHEDULE FOR LOWSIDE**

REFERENCE DRAWNG	GROUP 1	MEMBER 1	GROUP 2	MEMBER 2	GROUP 3	MEMBER 3	SHOP/FIELD	BOLT QUANTITY	BOLT DIAMETER (in.)	BOLT LENGTH (in.)	BOLT NUMBER
LS-16	G114	ANG157	G114	ANG157	G114	B114	FIELD	2	5/8	2 1/2	B-4
LS-16	G114	ANG157	G114	ANG157	G114	B114	FIELD	2	5/8	2 1/2	B-4
LS-16	G114	ANG157	G114	ANG157	G114	B114	FIELD	2	5/8	2 1/2	B-4
LS-16	G114	ANG157	G114	ANG157	G114	B114	FIELD	2	5/8	2 1/2	B-4
LS-19	G120	ANG157	G120	ANG157	G120	B120	FIELD	4	5/8	2 1/2	B-4
LS-19	G120	ANG157	G120	ANG157	G120	B120	FIELD	4	5/8	2 1/2	B-4
LS-19	G120	ANG157	G120	ANG157	G120	B120	FIELD	4	5/8	2 1/2	B-4
LS-19	G120	ANG157	G120	ANG157	G120	B120	FIELD	4	5/8	2 1/2	B-4
LS-11	G111	ANG147	G111	CH111			FIELD	4	5/8	2	B-2
LS-11	G111	ANG147	G111	CH111			FIELD	4	5/8	2	B-2
LS-11	G111	ANG147	G111	CH120			FIELD	4	5/8	2	B-2
LS-11	G111	ANG147	G111	CH120			FIELD	4	5/8	2	B-2
LS-11	G111	PL149	G111	ANG137			FIELD	1	5/8	1 3/4	B-1
LS-11	G111	PL149	G111	ANG137	G111	ANG131	FIELD	1	5/8	1 3/4	B-1
LS-11	G111	PL149	G111	ANG131	G111	ANG131	FIELD	1	5/8	1 3/4	B-1
LS-11	G111	PL149	G111	ANG131	G111	ANG131	FIELD	1	5/8	1 3/4	B-1
LS-11	G111	PL149	G111	ANG131	G111	ANG125	FIELD	1	5/8	1 3/4	B-1
LS-11	G111	PL149	G111	ANG125	G111	ANG125	FIELD	1	5/8	1 3/4	B-1
LS-11	G111	PL149	G111	ANG125	G111	ANG125	FIELD	1	5/8	1 3/4	B-1
LS-11	G111	PL149	G111	ANG125	G111	ANG125	FIELD	1	5/8	1 3/4	B-1
LS-11	G111	PL149	G111	ANG125	G111	ANG125	FIELD	1	5/8	1 3/4	B-1
LS-11	G111	PL149	G111	ANG131	G111	ANG125	FIELD	1	5/8	1 3/4	B-1
LS-11	G111	PL149	G111	ANG131	G111	ANG131	FIELD	1	5/8	1 3/4	B-1
LS-11	G111	PL149	G111	ANG131	G111	ANG131	FIELD	1	5/8	1 3/4	B-1
LS-11	G111	PL149	G111	ANG137	G111	ANG131	FIELD	1	5/8	1 3/4	B-1
LS-11	G111	PL149	G111	ANG137			FIELD	1	5/8	1 3/4	B-1
LS-12	G112	ANG147	G112	CH112			FIELD	4	5/8	1 3/4	B-1
LS-12	G112	ANG147	G112	CH112			FIELD	4	5/8	1 3/4	B-1
LS-12	G112	ANG147	G112	CH121			FIELD	4	5/8	1 3/4	B-1
LS-12	G112	ANG147	G112	CH121			FIELD	4	5/8	1 3/4	B-1
LS-12	G112	PL149	G112	ANG137			FIELD	1	5/8	1 3/4	B-1
LS-12	G112	PL149	G112	ANG137	G112	ANG131	FIELD	1	5/8	1 3/4	B-1
LS-12	G112	PL149	G112	ANG131	G112	ANG131	FIELD	1	5/8	1 3/4	B-1
LS-12	G112	PL149	G112	ANG131	G112	ANG131	FIELD	1	5/8	1 3/4	B-1
LS-12	G112	PL149	G112	ANG131	G112	ANG125	FIELD	1	5/8	1 3/4	B-1
LS-12	G112	PL149	G112	ANG125	G112	ANG125	FIELD	1	5/8	1 3/4	B-1
LS-12	G112	PL149	G112	ANG125	G112	ANG125	FIELD	1	5/8	1 3/4	B-1
LS-12	G112	PL149	G112	ANG125	G112	ANG125	FIELD	1	5/8	1 3/4	B-1
LS-12	G112	PL149	G112	ANG131	G112	ANG125	FIELD	1	5/8	1 3/4	B-1
LS-12	G112	PL149	G112	ANG131	G112	ANG131	FIELD	1	5/8	1 3/4	B-1
LS-12	G112	PL149	G112	ANG131	G112	ANG131	FIELD	1	5/8	1 3/4	B-1



**Booth & Associates**  
2309 Rawwood Drive Suite 300, Raleigh, NC 27607  
N.C. F. 6221



**PRELIMINARY -  
DO NOT USE FOR  
CONSTRUCTION**

© 05/2023

NO.	ISSUED FOR BID	REVISIONS	ENG.	DATE
			VK	06/10/2023

PROJECT NAME: CUMBERLAND ROAD 69 TO 15 X 25 KV SUBSTATION  
DRAWING TITLE: BOLT SCHEDULE

DRAWN BY:	DJD
CHECKED BY:	VK
APPROVED BY:	VK
DATE:	05/10/2023
SCALE:	N.T.S.
FILE NUMBER:	12510
SHEET:	

**BOLT SCHEDULE FOR LOWSIDE (CONT.)**

REFERENCE DRAWING	GROUP 1	MEMBER 1	GROUP 2	MEMBER 2	GROUP 3	MEMBER 3	SHOP/FIELD	BOLT QUANTITY	BOLT DIAMETER (in.)	BOLT LENGTH (in.)	BOLT NUMBER
LS-12	G112	PL149	G112	ANG137	G112	ANG131	FIELD	1	5/8	1 3/4	B-1
LS-12	G112	PL149	G112	ANG137			FIELD	1	5/8	1 3/4	B-1
LS-11	G111	ANG147	G111	CH111			FIELD	4	5/8	1 3/4	B-1
LS-11	G111	ANG147	G111	CH111			FIELD	4	5/8	1 3/4	B-1
LS-11	G111	ANG147	G111	CH120			FIELD	4	5/8	1 3/4	B-1
LS-11	G111	ANG147	G111	CH120			FIELD	4	5/8	1 3/4	B-1
LS-11	G111	PL149	G111	ANG137			FIELD	1	5/8	1 3/4	B-1
LS-11	G111	PL149	G111	ANG137	G111	ANG131	FIELD	1	5/8	1 3/4	B-1
LS-11	G111	PL149	G111	ANG131	G111	ANG131	FIELD	1	5/8	1 3/4	B-1
LS-11	G111	PL149	G111	ANG131	G111	ANG131	FIELD	1	5/8	1 3/4	B-1
LS-11	G111	PL149	G111	ANG131	G111	ANG125	FIELD	1	5/8	1 3/4	B-1
LS-11	G111	PL149	G111	ANG125	G111	ANG125	FIELD	1	5/8	1 3/4	B-1
LS-11	G111	PL149	G111	ANG125	G111	ANG125	FIELD	1	5/8	1 3/4	B-1
LS-11	G111	PL149	G111	ANG125	G111	ANG125	FIELD	1	5/8	1 3/4	B-1
LS-11	G111	PL149	G111	ANG125	G111	ANG125	FIELD	1	5/8	1 3/4	B-1
LS-11	G111	PL149	G111	ANG131	G111	ANG125	FIELD	1	5/8	1 3/4	B-1
LS-11	G111	PL149	G111	ANG131	G111	ANG131	FIELD	1	5/8	1 3/4	B-1
LS-11	G111	PL149	G111	ANG131	G111	ANG131	FIELD	1	5/8	1 3/4	B-1
LS-11	G111	PL149	G111	ANG137	G111	ANG131	FIELD	1	5/8	1 3/4	B-1
LS-11	G111	PL149	G111	ANG137			FIELD	1	5/8	1 3/4	B-1
LS-11	G111	ANG147	G111	CH111			FIELD	4	5/8	1 3/4	B-1
LS-11	G111	ANG147	G111	CH111			FIELD	4	5/8	1 3/4	B-1
LS-11	G111	ANG147	G111	CH120			FIELD	4	5/8	1 3/4	B-1
LS-11	G111	ANG147	G111	CH120			FIELD	4	5/8	1 3/4	B-1
LS-11	G111	PL149	G111	ANG137			FIELD	1	5/8	1 3/4	B-1
LS-11	G111	PL149	G111	ANG137	G111	ANG131	FIELD	1	5/8	1 3/4	B-1
LS-11	G111	PL149	G111	ANG131	G111	ANG131	FIELD	1	5/8	1 3/4	B-1
LS-11	G111	PL149	G111	ANG131	G111	ANG131	FIELD	1	5/8	1 3/4	B-1
LS-11	G111	PL149	G111	ANG131	G111	ANG125	FIELD	1	5/8	1 3/4	B-1
LS-11	G111	PL149	G111	ANG125	G111	ANG125	FIELD	1	5/8	1 3/4	B-1
LS-11	G111	PL149	G111	ANG125	G111	ANG125	FIELD	1	5/8	1 3/4	B-1
LS-11	G111	PL149	G111	ANG125	G111	ANG125	FIELD	1	5/8	1 3/4	B-1
LS-11	G111	PL149	G111	ANG131	G111	ANG125	FIELD	1	5/8	1 3/4	B-1
LS-11	G111	PL149	G111	ANG131	G111	ANG131	FIELD	1	5/8	1 3/4	B-1
LS-11	G111	PL149	G111	ANG131	G111	ANG131	FIELD	1	5/8	1 3/4	B-1
LS-11	G111	PL149	G111	ANG137	G111	ANG131	FIELD	1	5/8	1 3/4	B-1
LS-11	G111	PL149	G111	ANG137			FIELD	1	5/8	1 3/4	B-1
LS-14	G115	ANG147	G115	CH115			FIELD	4	5/8	1 3/4	B-1
LS-14	G115	ANG147	G115	CH115			FIELD	4	5/8	1 3/4	B-1
LS-14	G115	ANG147	G115	CH115			FIELD	4	5/8	1 3/4	B-1
LS-14	G115	ANG147	G115	CH115			FIELD	4	5/8	1 3/4	B-1



**PRELIMINARY -  
DO NOT USE FOR  
CONSTRUCTION**

© 05/2023

NO.	ISSUED FOR BID	REVISIONS	ENG.	DATE					
					A	B	C	D	E
			VK	06/10/2023					

PROJECT NAME:	CUMBERLAND ROAD 69 TO 15 X 25 kV SUBSTATION
DRAWING TITLE:	BOLT SCHEDULE
DRAWN BY:	DJD
CHECKED BY:	VK
APPROVED BY:	VK
DATE:	05/10/2023
SCALE:	N.T.S.
FILE NUMBER:	12510
SHEET:	

**BOLT SCHEDULE FOR LOWSIDE (CONT.)**

REFERENCE DRAWNG	GROUP 1	MEMBER 1	GROUP 2	MEMBER 2	GROUP 3	MEMBER 3	SHOP/FIELD	BOLT QUANTITY	BOLT DIAMETER (in.)	BOLT LENGTH (in.)	BOLT NUMBER
LS-14	G115	PL149	G115	ANG129			FIELD	1	5/8	1 3/4	B-1
LS-14	G115	PL149	G115	ANG129	G115	ANG129	FIELD	1	5/8	1 3/4	B-1
LS-14	G115	PL149	G115	ANG129	G115	ANG131	FIELD	1	5/8	1 3/4	B-1
LS-14	G115	PL149	G115	ANG131	G115	ANG131	FIELD	1	5/8	1 3/4	B-1
LS-14	G115	PL149	G115	ANG131	G115	ANG131	FIELD	1	5/8	1 3/4	B-1
LS-14	G115	PL149	G115	ANG129	G115	ANG131	FIELD	1	5/8	1 3/4	B-1
LS-14	G115	PL149	G115	ANG129	G115	ANG129	FIELD	1	5/8	1 3/4	B-1
LS-14	G115	PL149	G115	ANG129			FIELD	1	5/8	1 3/4	B-1
LS-14	G115	ANG147	G115	CH115			FIELD	4	5/8	1 3/4	B-1
LS-14	G115	ANG147	G115	CH115			FIELD	4	5/8	1 3/4	B-1
LS-14	G115	ANG147	G115	CH115			FIELD	4	5/8	1 3/4	B-1
LS-14	G115	ANG147	G115	CH115			FIELD	4	5/8	1 3/4	B-1
LS-14	G115	PL149	G115	ANG129			FIELD	1	5/8	1 3/4	B-1
LS-14	G115	PL149	G115	ANG129	G115	ANG129	FIELD	1	5/8	1 3/4	B-1
LS-14	G115	PL149	G115	ANG131	G115	ANG131	FIELD	1	5/8	1 3/4	B-1
LS-14	G115	PL149	G115	ANG131	G115	ANG131	FIELD	1	5/8	1 3/4	B-1
LS-14	G115	PL149	G115	ANG131	G115	ANG131	FIELD	1	5/8	1 3/4	B-1
LS-14	G115	PL149	G115	ANG129	G115	ANG131	FIELD	1	5/8	1 3/4	B-1
LS-14	G115	PL149	G115	ANG129	G115	ANG129	FIELD	1	5/8	1 3/4	B-1
LS-14	G115	ANG147	G115	CH115			FIELD	4	5/8	1 3/4	B-1
LS-14	G115	ANG147	G115	CH115			FIELD	4	5/8	1 3/4	B-1
LS-14	G115	ANG147	G115	CH115			FIELD	4	5/8	1 3/4	B-1
LS-14	G115	PL149	G115	ANG129			FIELD	1	5/8	1 3/4	B-1
LS-14	G115	PL149	G115	ANG129	G115	ANG129	FIELD	1	5/8	1 3/4	B-1
LS-14	G115	PL149	G115	ANG129	G115	ANG131	FIELD	1	5/8	1 3/4	B-1
LS-14	G115	PL149	G115	ANG131	G115	ANG131	FIELD	1	5/8	1 3/4	B-1
LS-14	G115	PL149	G115	ANG131	G115	ANG131	FIELD	1	5/8	1 3/4	B-1
LS-14	G115	PL149	G115	ANG131	G115	ANG131	FIELD	1	5/8	1 3/4	B-1
LS-14	G115	PL149	G115	ANG129	G115	ANG131	FIELD	1	5/8	1 3/4	B-1
LS-14	G115	PL149	G115	ANG129	G115	ANG129	FIELD	1	5/8	1 3/4	B-1
LS-14	G115	ANG147	G115	CH115			FIELD	4	5/8	1 3/4	B-1
LS-14	G115	ANG147	G115	CH115			FIELD	4	5/8	1 3/4	B-1
LS-14	G115	ANG147	G115	CH115			FIELD	4	5/8	1 3/4	B-1
LS-14	G115	PL149	G115	ANG129			FIELD	1	5/8	1 3/4	B-1



**PRELIMINARY -  
DO NOT USE FOR  
CONSTRUCTION**

© 05/2023

NO.	ISSUED FOR BID	REVISIONS	ENG.	DATE
A			VK	06/10/2023

PROJECT NAME: CUMBERLAND ROAD  
69 TO 15 X 25 KV  
SUBSTATION

DRAWING TITLE: BOLT SCHEDULE

DRAWN BY: DJD  
CHECKED BY: VK  
APPROVED BY: VK  
DATE: 05/10/2023  
SCALE: N.T.S.  
FILE NUMBER: 12510  
SHEET:

BOLT SCHEDULE FOR LOWSIDE (CONT.)

REFERENCE DRAWING	GROUP 1	MEMBER 1	GROUP 2	MEMBER 2	GROUP 3	MEMBER 3	SHOP/FIELD	BOLT QUANTITY	BOLT DIAMETER (in.)	BOLT LENGTH (in.)	BOLT NUMBER
LS-14	G115	PL149	G115	ANG129	G115	ANG129	FIELD	1	5/8	1 3/4	B-1
LS-14	G115	PL149	G115	ANG129	G115	ANG131	FIELD	1	5/8	1 3/4	B-1
LS-14	G115	PL149	G115	ANG131	G115	ANG131	FIELD	1	5/8	1 3/4	B-1
LS-14	G115	PL149	G115	ANG131	G115	ANG131	FIELD	1	5/8	1 3/4	B-1
LS-14	G115	PL149	G115	ANG131	G115	ANG131	FIELD	1	5/8	1 3/4	B-1
LS-14	G115	PL149	G115	ANG129	G115	ANG131	FIELD	1	5/8	1 3/4	B-1
LS-14	G115	PL149	G115	ANG129	G115	ANG129	FIELD	1	5/8	1 3/4	B-1
LS-14	G115	ANG147	G115	CH115			FIELD	4	5/8	1 3/4	B-1
LS-14	G115	ANG147	G115	CH115			FIELD	4	5/8	1 3/4	B-1
LS-14	G115	ANG147	G115	CH115			FIELD	4	5/8	1 3/4	B-1
LS-14	G115	ANG147	G115	CH115			FIELD	4	5/8	1 3/4	B-1
LS-14	G115	PL149	G115	ANG129			FIELD	1	5/8	1 3/4	B-1
LS-14	G115	PL149	G115	ANG129	G115	ANG129	FIELD	1	5/8	1 3/4	B-1
LS-14	G115	PL149	G115	ANG129	G115	ANG131	FIELD	1	5/8	1 3/4	B-1
LS-14	G115	PL149	G115	ANG131	G115	ANG131	FIELD	1	5/8	1 3/4	B-1
LS-14	G115	PL149	G115	ANG131	G115	ANG131	FIELD	1	5/8	1 3/4	B-1
LS-14	G115	PL149	G115	ANG131	G115	ANG131	FIELD	1	5/8	1 3/4	B-1
LS-14	G115	PL149	G115	ANG129	G115	ANG131	FIELD	1	5/8	1 3/4	B-1
LS-14	G115	PL149	G115	ANG129	G115	ANG129	FIELD	1	5/8	1 3/4	B-1
LS-14	G115	PL149	G115	ANG129			FIELD	1	5/8	1 3/4	B-1
LS-14	G115	ANG147	G115	CH115			FIELD	4	5/8	1 3/4	B-1
LS-14	G115	ANG147	G115	CH115			FIELD	4	5/8	1 3/4	B-1
LS-14	G115	ANG147	G115	CH115			FIELD	4	5/8	1 3/4	B-1
LS-14	G115	ANG147	G115	CH115			FIELD	4	5/8	1 3/4	B-1
LS-14	G115	PL149	G115	ANG129			FIELD	1	5/8	1 3/4	B-1
LS-14	G115	PL149	G115	ANG129	G115	ANG129	FIELD	1	5/8	1 3/4	B-1
LS-14	G115	PL149	G115	ANG129	G115	ANG131	FIELD	1	5/8	1 3/4	B-1
LS-14	G115	PL149	G115	ANG131	G115	ANG131	FIELD	1	5/8	1 3/4	B-1
LS-14	G115	PL149	G115	ANG131	G115	ANG131	FIELD	1	5/8	1 3/4	B-1
LS-14	G115	PL149	G115	ANG131	G115	ANG131	FIELD	1	5/8	1 3/4	B-1
LS-14	G115	PL149	G115	ANG129	G115	ANG131	FIELD	1	5/8	1 3/4	B-1
LS-14	G115	PL149	G115	ANG129	G115	ANG129	FIELD	1	5/8	1 3/4	B-1
LS-14	G115	PL149	G115	ANG129			FIELD	1	5/8	1 3/4	B-1
LS-03; LS-17	G117	PL155	G100.2	PL155			FIELD	4	5/8	2	B-2
LS-03; LS-17	G117	PL155	G100.2	PL155			FIELD	4	5/8	2	B-2
LS-03; LS-17	G117	PL155	G100.2	PL155			FIELD	4	5/8	2	B-2
LS-03; LS-17	G118	PL155	G100.2	PL155			FIELD	4	5/8	2	B-2
LS-03; LS-17	G118	PL155	G100.2	PL155			FIELD	4	5/8	2	B-2
LS-03; LS-17	G118	PL155	G100.2	PL155			FIELD	4	5/8	2	B-2



Booth & Associates  
2209 Reynolds Drive Suite 300, Raleigh, NC 27607  
N.C.F. 0221



PRELIMINARY -  
DO NOT USE FOR  
CONSTRUCTION

© 05/2023

NO.	ISSUED FOR BID	REVISIONS		NO.	DATE
		ENG.	DATE		
A					06/10/2023

PROJECT NAME: CUMBERLAND ROAD  
69 TO 15 X 25 kV  
SUBSTATION

DRAWING TITLE:  
BOLT SCHEDULE

DRAWN BY:	DJD
CHECKED BY:	VK
APPROVED BY:	VK
DATE:	05/10/2023
SCALE:	N.T.S.
FILE NUMBER:	12510
SHEET:	

**BOLT SCHEDULE FOR LOWSIDE (CONT.)**

REFERENCE DRAWING	GROUP 1	MEMBER 1	GROUP 2	MEMBER 2	GROUP 3	MEMBER 3	SHOP/FIELD	BOLT QUANTITY	BOLT DIAMETER (in.)	BOLT LENGTH (in.)	BOLT NUMBER
LS-03; LS-17	G117	PL155	G100.2	PL155			FIELD	4	5/8	2	B-2
LS-03; LS-17	G117	PL155	G100.2	PL155			FIELD	4	5/8	2	B-2
LS-03; LS-17	G117	PL155	G100.2	PL155			FIELD	4	5/8	2	B-2
LS-01; LS-17	G118	PL155	G100	PL155			FIELD	4	5/8	2	B-2
LS-01; LS-17	G118	PL155	G100	PL155			FIELD	4	5/8	2	B-2
LS-01; LS-17	G118	PL155	G100	PL155			FIELD	4	5/8	2	B-2
LS-02; LS-17	G118	PL155	G100.1	PL155			FIELD	4	5/8	2	B-2
LS-02; LS-17	G118	PL155	G100.1	PL155			FIELD	4	5/8	2	B-2
LS-02; LS-17	G118	PL155	G100.1	PL155			FIELD	4	5/8	2	B-2
LS-01; LS-17	G118	PL155	G100	PL155			FIELD	4	5/8	2	B-2
LS-01; LS-17	G118	PL155	G100	PL155			FIELD	4	5/8	2	B-2
LS-01; LS-17	G118	PL155	G100	PL155			FIELD	4	5/8	2	B-2
LS-03; LS-17	G117	PL155	G100.2	PL155			FIELD	4	5/8	2	B-2
LS-03; LS-17	G117	PL155	G100.2	PL155			FIELD	4	5/8	2	B-2
LS-03; LS-17	G117	PL155	G100.2	PL155			FIELD	4	5/8	2	B-2
LS-03; LS-17	G118	PL155	G100.2	PL155			FIELD	4	5/8	2	B-2
LS-03; LS-17	G118	PL155	G100.2	PL155			FIELD	4	5/8	2	B-2
LS-03; LS-17	G118	PL155	G100.2	PL155			FIELD	4	5/8	2	B-2
LS-03; LS-17	G117	PL155	G100.2	PL155			FIELD	4	5/8	2	B-2
LS-03; LS-17	G117	PL155	G100.2	PL155			FIELD	4	5/8	2	B-2
LS-08.1	G102.1	ANG141.1	G102.1	C102.1			FIELD	2	5/8	2	B-2
LS-09	G109	ANG143	G109	C109			FIELD	2	5/8	2	B-2
LS-08	G102	ANG141	G102	C102			FIELD	2	5/8	2	B-2
LS-09	G109	ANG143	G109	C109			FIELD	2	5/8	2	B-2
LS-07	G104	ANG141	G104	C104			FIELD	2	5/8	2	B-2
LS-06	G101	ANG143	G101	C101			FIELD	2	5/8	2	B-2
LS-08	G102	ANG141	G102	C102			FIELD	2	5/8	2	B-2
LS-09	G109	ANG143	G109	C109			FIELD	2	5/8	2	B-2
LS-08	G102	ANG141	G102	C102			FIELD	2	5/8	2	B-2
LS-09	G109	ANG143	G109	C109			FIELD	2	5/8	2	B-2
LS-07	G104	ANG141	G104	C104			FIELD	2	5/8	2	B-2
LS-06	G101	ANG143	G101	C101			FIELD	2	5/8	2	B-2
LS-08.1; LS-17	ANG116	ANG116	G102.1	ANG150			FIELD	1	5/8	1 3/4	B-1
LS-09; LS-17	ANG116	ANG116	G109	ANG150			FIELD	1	5/8	1 3/4	B-1
LS-04; LS-17	ANG116	ANG116	G100.3	WT135			FIELD	1	5/8	1 3/4	B-1
LS-04; LS-17	ANG116	ANG116	G100.3	WT135			FIELD	1	5/8	1 3/4	B-1
LS-08; LS-17	ANG116	ANG116	G102	ANG150			FIELD	1	5/8	1 3/4	B-1
LS-08; LS-17	ANG116	ANG116	G102	ANG150			FIELD	1	5/8	1 3/4	B-1
LS-09; LS-17	ANG116	ANG116	G109	ANG150			FIELD	1	5/8	1 3/4	B-1



**PRELIMINARY - DO NOT USE FOR CONSTRUCTION**

© 05/2023

NO.	ISSUED FOR	REVISIONS	ENG.	DATE
A			VK	06/10/2023

PROJECT NAME: CUMBERLAND ROAD 69 TO 15 X 25 kV SUBSTATION  
 DRAWING TITLE: BOLT SCHEDULE

DRAWN BY:	DJD
CHECKED BY:	VK
APPROVED BY:	VK
DATE:	05/10/2023
SCALE:	N.T.S.
FILE NUMBER:	12510
SHEET:	

**BOLT SCHEDULE FOR LOWSIDE (CONT.)**

REFERENCE DRAWING	GROUP 1	MEMBER 1	GROUP 2	MEMBER 2	GROUP 3	MEMBER 3	SHOP/FIELD	BOLT QUANTITY	BOLT DIAMETER (in.)	BOLT LENGTH (in.)	BOLT NUMBER
LS-09; LS-17	ANG116	ANG116	G109	ANG150			FIELD	1	5/8	1 3/4	B-1
LS-03; LS-17	ANG116	ANG116	G100.2	WT135			FIELD	1	5/8	1 3/4	B-1
LS-03; LS-17	ANG116	ANG116	G100.2	WT135			FIELD	1	5/8	1 3/4	B-1
LS-03; LS-17	ANG116	ANG116	G100.2	WT135			FIELD	1	5/8	1 3/4	B-1
LS-03; LS-17	ANG116	ANG116	G100.2	WT135			FIELD	1	5/8	1 3/4	B-1
LS-07; LS-17	ANG116	ANG116	G104	ANG150			FIELD	1	5/8	1 3/4	B-1
LS-07; LS-17	ANG116	ANG116	G104	ANG150			FIELD	1	5/8	1 3/4	B-1
LS-06; LS-17	ANG116	ANG116	G101	ANG150			FIELD	1	5/8	1 3/4	B-1
LS-06; LS-17	ANG116	ANG116	G101	ANG150			FIELD	1	5/8	1 3/4	B-1
LS-01; LS-17	ANG116	ANG116	G100	WT135			FIELD	1	5/8	1 3/4	B-1
LS-01; LS-17	ANG116	ANG116	G100	WT135			FIELD	1	5/8	1 3/4	B-1
LS-01; LS-17	ANG116	ANG116	G100	WT135			FIELD	1	5/8	1 3/4	B-1
LS-01; LS-17	ANG116	ANG116	G100	WT135			FIELD	1	5/8	1 3/4	B-1
LS-08; LS-17	ANG116	ANG116	G102	ANG150			FIELD	1	5/8	1 3/4	B-1
LS-08; LS-17	ANG116	ANG116	G102	ANG150			FIELD	1	5/8	1 3/4	B-1
LS-09; LS-17	ANG116	ANG116	G109	ANG150			FIELD	1	5/8	1 3/4	B-1
LS-09; LS-17	ANG116	ANG116	G109	ANG150			FIELD	1	5/8	1 3/4	B-1
LS-02; LS-17	ANG116	ANG116	G100.1	WT135			FIELD	1	5/8	1 3/4	B-1
LS-02; LS-17	ANG116	ANG116	G100.1	WT135			FIELD	1	5/8	1 3/4	B-1
LS-02; LS-17	ANG116	ANG116	G100.1	WT135			FIELD	1	5/8	1 3/4	B-1
LS-02; LS-17	ANG116	ANG116	G100.1	WT135			FIELD	1	5/8	1 3/4	B-1
LS-08; LS-17	ANG116	ANG116	G102	ANG150			FIELD	1	5/8	1 3/4	B-1
LS-08; LS-17	ANG116	ANG116	G102	ANG150			FIELD	1	5/8	1 3/4	B-1
LS-09; LS-17	ANG116	ANG116	G109	ANG150			FIELD	1	5/8	1 3/4	B-1
LS-09; LS-17	ANG116	ANG116	G109	ANG150			FIELD	1	5/8	1 3/4	B-1
LS-01; LS-17	ANG116	ANG116	G100	WT135			FIELD	1	5/8	1 3/4	B-1
LS-01; LS-17	ANG116	ANG116	G100	WT135			FIELD	1	5/8	1 3/4	B-1
LS-01; LS-17	ANG116	ANG116	G100	WT135			FIELD	1	5/8	1 3/4	B-1
LS-07; LS-17	ANG116	ANG116	G104	ANG150			FIELD	1	5/8	1 3/4	B-1
LS-07; LS-17	ANG116	ANG116	G104	ANG150			FIELD	1	5/8	1 3/4	B-1
LS-06; LS-17	ANG116	ANG116	G101	ANG150			FIELD	1	5/8	1 3/4	B-1
LS-06; LS-17	ANG116	ANG116	G101	ANG150			FIELD	1	5/8	1 3/4	B-1
LS-03; LS-17	ANG116	ANG116	G100.2	WT135			FIELD	1	5/8	1 3/4	B-1
LS-03; LS-17	ANG116	ANG116	G100.2	WT135			FIELD	1	5/8	1 3/4	B-1
LS-03; LS-17	ANG116	ANG116	G100.2	WT135			FIELD	1	5/8	1 3/4	B-1
LS-03; LS-17	ANG116	ANG116	G100.2	WT135			FIELD	1	5/8	1 3/4	B-1
ED-7; LS-04; LS-08.1	G100.3	PL152	G102.1	PL152			FIELD	4	5/8	2 3/4	B-5
ED-7; LS-04; LS-09	G100.3	PL152	G109	PL152			FIELD	4	5/8	2 3/4	B-5
LS-03; LS-08	G100.2	PL152	G102	PL152			FIELD	4	5/8	2 3/4	B-5



**PRELIMINARY -  
DO NOT USE FOR  
CONSTRUCTION**

© 05/2023

NO.	A	ISSUED FOR BID	REVISIONS	ENG.	DATE
				VK	06/10/2023

PROJECT NAME: CUMBERLAND ROAD 69 TO 15 X 25 KV SUBSTATION	DRAWING TITLE: <b>BOLT SCHEDULE</b>
DRAWN BY: DJD	
CHECKED BY: VK	
APPROVED BY: VK	
DATE: 05/10/2023	
SCALE: N.T.S.	
FILE NUMBER: 12510	
SHEET:	

**BOLT SCHEDULE FOR LOWSIDE (CONT.)**

REFERENCE DRAWING	GROUP 1	MEMBER 1	GROUP 2	MEMBER 2	GROUP 3	MEMBER 3	SHOP/FIELD	BOLT QUANTITY	BOLT DIAMETER (in.)	BOLT LENGTH (in.)	BOLT NUMBER
LS-03; LS-09	G100.2	PL152	G109	PL152			FIELD	4	5/8	2 3/4	B-5
ED-8; LS-01; LS-07	G100	PL152	G104	PL152			FIELD	4	5/8	2 3/4	B-5
ED-8; LS-01; LS-06	G100	PL152	G101	PL152			FIELD	4	5/8	2 3/4	B-5
ED-9; LS-02; LS-08	G100.1	PL152	G102	PL152			FIELD	4	5/8	2 3/4	B-5
ED-9; LS-02; LS-09	G100.1	PL152	G109	PL152			FIELD	4	5/8	2 3/4	B-5
LS-01; LS-08	G100	PL152	G102	PL152			FIELD	4	5/8	2 3/4	B-5
LS-01; LS-09	G100	PL152	G109	PL152			FIELD	4	5/8	2 3/4	B-5
ED-10; LS-03; LS-07	G100.2	PL152	G104	PL152			FIELD	4	5/8	2 3/4	B-5
ED-10; LS-03; LS-06	G100.2	PL152	G101	PL152			FIELD	4	5/8	2 3/4	B-5
ED-6; LS-19; LS-08.1	G120	ANG157	G102.1	C102.1			FIELD	4	5/8	2	B-2
ED-6; LS-19; LS-08	G120	ANG157	G102	C102			FIELD	4	5/8	2	B-2
LS-19; LS-09	G120	ANG157	G109	C109			FIELD	4	5/8	2	B-2
LS-19; LS-09	G120	ANG157	G109	C109			FIELD	4	5/8	2	B-2
ED-6; LS-16; LS-08	G114	ANG157	G102	C102			FIELD	4	5/8	2	B-2
ED-6; LS-16; LS-08	G114	ANG157	G102	C102			FIELD	4	5/8	2	B-2
LS-16; LS-09	G114	ANG157	G109	C109			FIELD	4	5/8	2	B-2
LS-16; LS-09	G114	ANG157	G109	C109			FIELD	4	5/8	2	B-2
ED-7; LS-11; LS-08.1	G111	ANG147	G102.1	C102.1			FIELD	4	5/8	2	B-2
ED-7; LS-11; LS-08.1	G111	ANG147	G102.1	C102.1			FIELD	4	5/8	2	B-2
ED-7; LS-11; LS-09	G111	ANG147	G109	C109			FIELD	4	5/8	2	B-2
ED-7; LS-11; LS-09	G111	ANG147	G109	C109			FIELD	4	5/8	2	B-2
LS-12; LS-08	G112	ANG147	G102	C102			FIELD	4	5/8	2	B-2
LS-12; LS-08	G112	ANG147	G102	C102			FIELD	4	5/8	2	B-2
LS-11; LS-09	G112	ANG147	G109	C109			FIELD	4	5/8	2	B-2
LS-11; LS-09	G112	ANG147	G109	C109			FIELD	4	5/8	2	B-2
ED-9; LS-11; LS-08	G111	ANG147	G102	C102			FIELD	4	5/8	2	B-2
ED-9; LS-11; LS-08	G111	ANG147	G102	C102			FIELD	4	5/8	2	B-2
ED-9; LS-11; LS-09	G111	ANG147	G109	C109			FIELD	4	5/8	2	B-2
ED-9; LS-11; LS-09	G111	ANG147	G109	C109			FIELD	4	5/8	2	B-2
ED-10; LS-11; LS-07	G111	ANG147	G104	C104			FIELD	4	5/8	2	B-2
ED-10; LS-11; LS-07	G111	ANG147	G104	C104			FIELD	4	5/8	2	B-2
ED-10; LS-11; LS-06	G111	ANG147	G101	C101			FIELD	4	5/8	2	B-2
ED-10; LS-11; LS-06	G111	ANG147	G101	C101			FIELD	4	5/8	2	B-2
ED-6; LS-14; LS-08	G115	ANG147	G102	C102			FIELD	4	5/8	2	B-2
ED-6; LS-14; LS-08	G115	ANG147	G102	C102			FIELD	4	5/8	2	B-2
ED-6; LS-14; LS-07	G115	ANG147	G104	C104	G115	ANG147	FIELD	4	5/8	2 1/2	B-4
ED-6; LS-14; LS-07	G115	ANG147	G104	C104	G115	ANG147	FIELD	4	5/8	2 1/2	B-4
ED-6; LS-14; LS-08	G115	ANG147	G102	C102			FIELD	4	5/8	2	B-2
ED-6; LS-14; LS-08	G115	ANG147	G102	C102			FIELD	4	5/8	2	B-2
ED-6; LS-14; LS-08	G115	ANG147	G102	C102			FIELD	4	5/8	2	B-2



**PRELIMINARY - DO NOT USE FOR CONSTRUCTION**

© 05/2023

NO.	ISSUED FOR BID	REVISIONS	ENG.	DATE
A			VK	06/10/2023

PROJECT NAME: <b>CUMBERLAND ROAD 69 TO 15 X 25 KV SUBSTATION</b>	DRAWING TITLE: <b>BOLT SCHEDULE</b>
DRAWN BY: DJD	CHECKED BY: VK
APPROVED BY: VK	DATE: 05/10/2023
SCALE: N.T.S.	FILE NUMBER: 12510
SHEET:	BS-8



**BOLT SCHEDULE FOR LOWSIDE (CONT.)**

REFERENCE DRAWNG	GROUP 1	MEMBER 1	GROUP 2	MEMBER 2	GROUP 3	MEMBER 3	SHOP/FIELD	BOLT QUANTITY	BOLT DIAMETER (in.)	BOLT LENGTH (in.)	BOLT NUMBER
ED-6; LS-14; LS-08	G115	ANG147	G102	C102			FIELD	4	5/8	2	B-2
ED-6; LS-14; LS-07	G115	ANG147	G104	C104			FIELD	4	5/8	2	B-2
ED-6; LS-14; LS-07	G115	ANG147	G104	C104			FIELD	4	5/8	2	B-2
ED-6; LS-14; LS-09	G115	ANG147	G109	C109			FIELD	4	5/8	2	B-2
ED-6; LS-14; LS-09	G115	ANG147	G109	C109			FIELD	4	5/8	2	B-2
ED-6; LS-14; LS-06	G115	ANG147	G101	C101	G115	ANG147	FIELD	4	5/8	2 1/2	B-4
ED-6; LS-14; LS-06	G115	ANG147	G101	C101	G115	ANG147	FIELD	4	5/8	2 1/2	B-4
ED-6; LS-14; LS-09	G115	ANG147	G109	C109			FIELD	4	5/8	2	B-2
ED-6; LS-14; LS-09	G115	ANG147	G109	C109			FIELD	4	5/8	2	B-2
ED-6; LS-14; LS-09	G115	ANG147	G109	C109			FIELD	4	5/8	2	B-2
ED-6; LS-14; LS-09	G115	ANG147	G109	C109			FIELD	4	5/8	2	B-2
ED-6; LS-14; LS-06	G115	ANG147	G101	C101			FIELD	4	5/8	2	B-2
ED-6; LS-14; LS-06	G115	ANG147	G101	C101			FIELD	4	5/8	2	B-2

**BOLT SCHEDULE FOR URD STAND**

REFERENCE DRAWNG	GROUP 1	MEMBER 1	GROUP 2	MEMBER 2	GROUP 3	MEMBER 3	SHOP/FIELD	BOLT QUANTITY	BOLT DIAMETER (in.)	BOLT LENGTH (in.)	BOLT NUMBER
URD-3	G203	B203	G203	ANG217			FIELD	4	5/8	2	B-2
URD-3	G203	B203	G203	ANG217			FIELD	4	5/8	2	B-2
ED-5; URD-1; URD-3	G200	C200	G203	ANG217			FIELD	4	5/8	2	B-2
ED-5; URD-1; URD-3	G200	C200	G203	ANG217			FIELD	4	5/8	2	B-2
URD-2	G201	ANG201	G201	ANG216			FIELD	4	5/8	1 3/4	B-1
URD-2	G201	ANG201	G201	ANG216			FIELD	4	5/8	1 3/4	B-1
URD-2	G201	ANG201	G201	ANG216			FIELD	4	5/8	1 3/4	B-1
URD-2	G201	ANG201	G201	ANG209			FIELD	2	5/8	1 3/4	B-1
URD-2	G201	ANG201	G201	ANG210			FIELD	2	5/8	1 3/4	B-1
ED-5; URD-1; URD-2	G200	C200	G201	ANG209			FIELD	2	5/8	2	B-2
ED-5; URD-1; URD-3	G200	C200	G201	ANG210			FIELD	2	5/8	2	B-2
URD-3	G204	ANG204	G204	ANG213			FIELD	1	5/8	2	B-2
URD-3	G206	ANG204	G204	ANG213			FIELD	1	5/8	2	B-2
URD-3	G204	ANG204	G204	ANG213			FIELD	1	5/8	2	B-2
URD-3	G206	ANG204	G204	ANG213			FIELD	1	5/8	2	B-2
ED-5; URD-1; URD-3	G200	C200	G204	ANG204			FIELD	2	5/8	2	B-2
ED-5; URD-1; URD-3	G200	C200	G204	ANG206			FIELD	2	5/8	2	B-2
ED-5; URD-1; URD-3	G200	C200	G204	ANG204			FIELD	2	5/8	2	B-2
ED-5; URD-1; URD-3	G200	C200	G204	ANG206			FIELD	2	5/8	2	B-2



**PRELIMINARY -  
DO NOT USE FOR  
CONSTRUCTION**

© 05/2023

NO.	DESCRIPTION	DATE	BY	REVISIONS

PROJECT NAME: **CUMBERLAND ROAD  
69 TO 15 X 25 KV  
SUBSTATION**

DRAWING TITLE: **BOLT SCHEDULE**

DRAWN BY: D.J.D.  
 CHECKED BY: VK  
 APPROVED BY: VK  
 DATE: 05/10/2023  
 SCALE: N.T.S.  
 FILE NUMBER: 12510  
 SHEET: BS-9

### BOLT SCHEDULE FOR A-FRAME

REFERENCE DRAWING	GROUP 1	MEMBER 1	GROUP 2	MEMBER 2	GROUP 3	MEMBER 3	SHOP/FIELD	BOLT QUANTITY	BOLT DIAMETER (in.)	BOLT LENGTH (in.)	BOLT NUMBER
AF-2	G310	ANG310	G310	BR331			FIELD	1	5/8	1 3/4	B-1
AF-2	G310	ANG310	G310	BR331			FIELD	1	5/8	1 3/4	B-1
AF-2	G310	ANG310	G310	BR338			FIELD	1	5/8	1 3/4	B-1
AF-2	G310	ANG310	G310	BR338			FIELD	1	5/8	1 3/4	B-1
AF-2	G310	ANG310	G310	BR338			FIELD	1	5/8	1 3/4	B-1
AF-2	G310	ANG310	G310	BR338			FIELD	1	5/8	1 3/4	B-1
AF-2	G310	ANG310	G310	BR338	G310	ANG327	FIELD	1	5/8	1 3/4	B-1
AF-2	G310	ANG310	G310	ANG327			FIELD	1	5/8	1 3/4	B-1
AF-2	G310	ANG310	G310	BR338			FIELD	1	5/8	1 3/4	B-1
AF-2	G310	ANG310	G310	BR338			FIELD	1	5/8	1 3/4	B-1
AF-2	G310	ANG310	G310	BR338			FIELD	1	5/8	1 3/4	B-1
AF-2	G310	ANG310	G310	BR338			FIELD	1	5/8	1 3/4	B-1
AF-2	G310	ANG310	G310	BR338			FIELD	1	5/8	1 3/4	B-1
AF-2	G310	ANG310	G310	BR338			FIELD	1	5/8	1 3/4	B-1
AF-2	G310	ANG310	G310	BR338			FIELD	1	5/8	1 3/4	B-1
AF-2	G310	ANG310	G310	BR338	G310	ANG327	FIELD	1	5/8	1 3/4	B-1
AF-2	G310	ANG310	G310	ANG327			FIELD	1	5/8	1 3/4	B-1
AF-2	G310	ANG310	G310	BR338			FIELD	1	5/8	1 3/4	B-1
AF-2	G310	ANG310	G310	BR338			FIELD	1	5/8	1 3/4	B-1
AF-2	G310	ANG310	G310	BR338			FIELD	1	5/8	1 3/4	B-1
AF-2	G310	ANG310	G310	BR338			FIELD	1	5/8	1 3/4	B-1
AF-2	G310	ANG310	G310	BR338	G310	ANG327	FIELD	1	5/8	1 3/4	B-1
AF-2	G310	ANG310	G310	ANG327			FIELD	1	5/8	1 3/4	B-1
AF-2	G310	ANG310	G310	BR338			FIELD	1	5/8	1 3/4	B-1
AF-2	G310	ANG310	G310	BR338			FIELD	1	5/8	1 3/4	B-1
AF-2	G310	ANG310	G310	BR338			FIELD	1	5/8	1 3/4	B-1
AF-2	G310	ANG310	G310	BR338			FIELD	1	5/8	1 3/4	B-1
AF-2	G310	ANG310	G310	BR338			FIELD	1	5/8	1 3/4	B-1
AF-2	G310	ANG310	G310	BR338			FIELD	1	5/8	1 3/4	B-1
AF-2	G310	ANG310	G310	BR338			FIELD	1	5/8	1 3/4	B-1
AF-2	G310	ANG310	G310	BR338			FIELD	1	5/8	1 3/4	B-1
AF-2	G310	ANG310	G310	BR338			FIELD	1	5/8	1 3/4	B-1
AF-2	G310	ANG310	G310	BR338			FIELD	1	5/8	1 3/4	B-1
AF-2	G310	ANG310	G310	BR338			FIELD	1	5/8	1 3/4	B-1



**BA Booth & Associates**  
2200 Remwood Drive Suite 300, Raleigh, NC 27607  
 NC F-6021

**PRELIMINARY - DO NOT USE FOR CONSTRUCTION**

© 05/2023		
NO.	REVISIONS	DATE
A	ISSUED FOR BID	06/10/2023

PROJECT NAME: **CUMBERLAND ROAD 69 TO 15 X 25 kV SUBSTATION**

DRAWING TITLE: **BOLT SCHEDULE**

DRAWN BY: DJD
CHECKED BY: VK
APPROVED BY: VK
DATE: 05/10/2023
SCALE: N.T.S.
FILE NUMBER: 12510
SHEET:

**BOLT SCHEDULE FOR A-FRAME (CONT.)**

REFERENCE DRAWING	GROUP 1	MEMBER 1	GROUP 2	MEMBER 2	GROUP 3	MEMBER 3	SHOP/FIELD	BOLT QUANTITY	BOLT DIAMETER (in.)	BOLT LENGTH (in.)	BOLT NUMBER
AF-2	G310	ANG310	G310	BR338	G310	ANG327	FIELD	1	5/8	1 3/4	B-1
AF-2	G310	ANG310	G310	ANG327			FIELD	1	5/8	1 3/4	B-1
AF-2	G310	ANG310	G310	BR338			FIELD	1	5/8	1 3/4	B-1
AF-2	G310	ANG310	G310	BR338			FIELD	1	5/8	1 3/4	B-1
AF-2	G310	ANG310	G310	BR338			FIELD	1	5/8	1 3/4	B-1
AF-2	G310	ANG310	G310	BR338			FIELD	1	5/8	1 3/4	B-1
AF-2	G310	ANG310	G310	BR338			FIELD	1	5/8	1 3/4	B-1
AF-2	G310	ANG310	G310	BR338			FIELD	1	5/8	1 3/4	B-1
AF-2	G310	ANG310	G310	BR338			FIELD	1	5/8	1 3/4	B-1
AF-2	G310	ANG310	G310	BR338			FIELD	1	5/8	1 3/4	B-1
AF-2	G310	ANG310	G310	BR338			FIELD	1	5/8	1 3/4	B-1
AF-2	G310	ANG310	G310	BR335			FIELD	1	5/8	1 3/4	B-1
AF-2	G310	ANG310	G310	BR335	G310	ANG327	FIELD	1	5/8	1 3/4	B-1
AF-2	G310	ANG310	G310	ANG327			FIELD	1	5/8	1 3/4	B-1
AF-2	G310	ANG310	G310	BR338			FIELD	1	5/8	1 3/4	B-1
AF-2	G310	ANG310	G310	BR338			FIELD	1	5/8	1 3/4	B-1
AF-2	G310	ANG310	G310	BR338			FIELD	1	5/8	1 3/4	B-1
AF-2	G310	ANG310	G310	BR338			FIELD	1	5/8	1 3/4	B-1
AF-2	G310	ANG310	G310	BR338			FIELD	1	5/8	1 3/4	B-1
AF-2	G310	ANG310	G310	BR338			FIELD	1	5/8	1 3/4	B-1
AF-2	G310	ANG310	G310	BR338	G310	ANG327	FIELD	1	5/8	1 3/4	B-1
AF-2	G310	ANG310	G310	ANG327			FIELD	1	5/8	1 3/4	B-1
AF-2	G310	ANG310	G310	BR338			FIELD	1	5/8	1 3/4	B-1
AF-2	G310	ANG310	G310	BR338			FIELD	1	5/8	1 3/4	B-1
AF-2	G310	ANG310	G310	BR338			FIELD	1	5/8	1 3/4	B-1
AF-2	G310	ANG310	G310	BR338			FIELD	1	5/8	1 3/4	B-1
AF-2	G310	ANG310	G310	BR331			FIELD	1	5/8	1 3/4	B-1
AF-2	G310	ANG310	G310	BR331			FIELD	1	5/8	1 3/4	B-1
AF-2	G310	ANG310	G310	BR331			FIELD	1	5/8	1 3/4	B-1
AF-2	G310	ANG310	G310	BR331			FIELD	1	5/8	1 3/4	B-1
AF-2	G310	ANG310	G310	BR338			FIELD	1	5/8	1 3/4	B-1
AF-2	G310	ANG310	G310	BR338			FIELD	1	5/8	1 3/4	B-1
AF-2	G310	ANG310	G310	BR338			FIELD	1	5/8	1 3/4	B-1
AF-2	G310	ANG310	G310	BR338			FIELD	1	5/8	1 3/4	B-1
AF-2	G310	ANG310	G310	BR338			FIELD	1	5/8	1 3/4	B-1
AF-2	G310	ANG310	G310	BR338	G310	ANG327	FIELD	1	5/8	1 3/4	B-1
AF-2	G310	ANG310	G310	ANG327			FIELD	1	5/8	1 3/4	B-1
AF-2	G310	ANG310	G310	BR338			FIELD	1	5/8	1 3/4	B-1
AF-2	G310	ANG310	G310	BR338			FIELD	1	5/8	1 3/4	B-1
AF-2	G310	ANG310	G310	BR338			FIELD	1	5/8	1 3/4	B-1
AF-2	G310	ANG310	G310	BR338			FIELD	1	5/8	1 3/4	B-1



**Booth & Associates**  
 2300 Rawlwood Drive, Suite 300, Raleigh, NC 27607  
 N.C. F. 0221



**PRELIMINARY - DO NOT USE FOR CONSTRUCTION**

© 05/2023

NO.	ISSUED FOR	REVISIONS	ENG.	DATE
A	FOR BID		VK	06/10/2023

PROJECT NAME: CUMBERLAND ROAD 69 TO 15 X 25 KV SUBSTATION  
 DRAWING TITLE: BOLT SCHEDULE

DRAWN BY:	DJD
CHECKED BY:	VK
APPROVED BY:	VK
DATE:	05/10/2023
SCALE:	N.T.S.
FILE NUMBER:	12510
SHEET:	

BOLT SCHEDULE FOR A-FRAME (CONT.)

REFERENCE DRAWING	GROUP 1	MEMBER 1	GROUP 2	MEMBER 2	GROUP 3	MEMBER 3	SHOP/FIELD	BOLT QUANTITY	BOLT DIAMETER (in.)	BOLT LENGTH (in.)	BOLT NUMBER
AF-2	G310	ANG310	G310	BR338			FIELD	1	5/8	1 3/4	B-1
AF-2	G310	ANG310	G310	BR335			FIELD	1	5/8	1 3/4	B-1
AF-2	G310	ANG310	G310	BR335	G310	ANG327	FIELD	1	5/8	1 3/4	B-1
AF-2	G310	ANG310	G310	ANG327			FIELD	1	5/8	1 3/4	B-1
AF-2	G310	ANG310	G310	BR338			FIELD	1	5/8	1 3/4	B-1
AF-2	G310	ANG310	G310	BR338			FIELD	1	5/8	1 3/4	B-1
AF-2	G310	ANG310	G310	BR338			FIELD	1	5/8	1 3/4	B-1
AF-2	G310	ANG310	G310	BR338			FIELD	1	5/8	1 3/4	B-1
AF-2	G310	ANG310	G310	BR338			FIELD	1	5/8	1 3/4	B-1
AF-2	G310	ANG310	G310	BR338	G310	ANG327	FIELD	1	5/8	1 3/4	B-1
AF-2	G310	ANG310	G310	ANG327			FIELD	1	5/8	1 3/4	B-1
AF-2	G310	ANG310	G310	BR338			FIELD	1	5/8	1 3/4	B-1
AF-2	G310	ANG310	G310	BR338			FIELD	1	5/8	1 3/4	B-1
AF-2	G310	ANG310	G310	BR338			FIELD	1	5/8	1 3/4	B-1
AF-2	G310	ANG310	G310	BR338			FIELD	1	5/8	1 3/4	B-1
AF-2	G310	ANG310	G310	BR338			FIELD	1	5/8	1 3/4	B-1
AF-2	G310	ANG310	G310	BR338			FIELD	1	5/8	1 3/4	B-1
AF-2	G310	ANG310	G310	BR331			FIELD	1	5/8	1 3/4	B-1
AF-2	G310	ANG310	G310	BR331			FIELD	1	5/8	1 3/4	B-1
AF-2	G310	ANG310	G310	BR331			FIELD	1	5/8	1 3/4	B-1
AF-2	G310	ANG310	G310	BR338			FIELD	1	5/8	1 3/4	B-1
AF-2	G310	ANG310	G310	BR338			FIELD	1	5/8	1 3/4	B-1
AF-2	G310	ANG310	G310	BR338			FIELD	1	5/8	1 3/4	B-1
AF-2	G310	ANG310	G310	BR338			FIELD	1	5/8	1 3/4	B-1
AF-2	G310	ANG310	G310	BR338			FIELD	1	5/8	1 3/4	B-1
AF-2	G310	ANG310	G310	BR338			FIELD	1	5/8	1 3/4	B-1
AF-2	G310	ANG310	G310	BR338			FIELD	1	5/8	1 3/4	B-1
AF-2	G310	ANG310	G310	BR338			FIELD	1	5/8	1 3/4	B-1
AF-2	G310	ANG310	G310	BR338			FIELD	1	5/8	1 3/4	B-1
AF-2	G310	ANG310	G310	BR338			FIELD	1	5/8	1 3/4	B-1
AF-2	G310	ANG310	G310	BR338	G310	ANG327	FIELD	1	5/8	1 3/4	B-1
AF-2	G310	ANG310	G310	ANG327			FIELD	1	5/8	1 3/4	B-1
AF-2	G310	ANG310	G310	BR338			FIELD	1	5/8	1 3/4	B-1
AF-2	G310	ANG310	G310	BR338			FIELD	1	5/8	1 3/4	B-1
AF-2	G310	ANG310	G310	BR338			FIELD	1	5/8	1 3/4	B-1
AF-2	G310	ANG310	G310	BR338			FIELD	1	5/8	1 3/4	B-1
AF-2	G310	ANG310	G310	BR338			FIELD	1	5/8	1 3/4	B-1
AF-2	G310	ANG310	G310	BR338			FIELD	1	5/8	1 3/4	B-1
AF-2	G310	ANG310	G310	BR338			FIELD	1	5/8	1 3/4	B-1
AF-2	G310	ANG310	G310	BR338			FIELD	1	5/8	1 3/4	B-1
AF-2	G310	ANG310	G310	BR338			FIELD	1	5/8	1 3/4	B-1
AF-2	G310	ANG310	G310	BR338			FIELD	1	5/8	1 3/4	B-1
AF-2	G310	ANG310	G310	BR338			FIELD	1	5/8	1 3/4	B-1



Booth & Associates  
2300 Renwood Drive Suite 300, Raleigh, NC 27607  
N.C. F. 0221



PRELIMINARY -  
DO NOT USE FOR  
CONSTRUCTION

© 05/2023

NO.	DESCRIPTION	DATE	REVISED BY	CHECKED BY	DATE
A	ISSUED FOR BID				

PROJECT NAME: CUMBERLAND ROAD  
69 TO 15 X 25 KV  
SUBSTATION

DRAWING TITLE:  
BOLT SCHEDULE

DRAWN BY:	DJD
CHECKED BY:	VK
APPROVED BY:	VK
DATE:	05/10/2023
SCALE:	N.T.S.
FILE NUMBER:	12510
SHEET:	

BOLT SCHEDULE FOR A-FRAME (CONT.)

REFERENCE DRAWING	GROUP 1	MEMBER 1	GROUP 2	MEMBER 2	GROUP 3	MEMBER 3	SHOP/FIELD	BOLT QUANTITY	BOLT DIAMETER (in.)	BOLT LENGTH (in.)	BOLT NUMBER
AF-2	G310	ANG310	G310	BR338			FIELD	1	5/8	1 3/4	B-1
AF-2	G310	ANG310	G310	BR338			FIELD	1	5/8	1 3/4	B-1
AF-2	G310	ANG310	G310	BR338			FIELD	1	5/8	1 3/4	B-1
AF-2	G310	ANG310	G310	BR338	G310	ANG327	FIELD	1	5/8	1 3/4	B-1
AF-2	G310	ANG310	G310	ANG327			FIELD	1	5/8	1 3/4	B-1
AF-2	G310	ANG310	G310	BR338			FIELD	1	5/8	1 3/4	B-1
AF-2	G310	ANG310	G310	BR338			FIELD	1	5/8	1 3/4	B-1
AF-2	G310	ANG310	G310	BR338			FIELD	1	5/8	1 3/4	B-1
AF-2	G310	ANG310	G310	BR338			FIELD	1	5/8	1 3/4	B-1
AF-2	G310	ANG310	G310	BR338			FIELD	1	5/8	1 3/4	B-1
AF-2	G310	ANG310	G310	BR331			FIELD	1	5/8	1 3/4	B-1
AF-2	G310	ANG310	G310	BR331			FIELD	1	5/8	1 3/4	B-1
AF-2	G310	ANG327	G310	BR332			FIELD	1	5/8	1 3/4	B-1
AF-2	G310	ANG327	G310	BR332			FIELD	1	5/8	1 3/4	B-1
AF-2	G310	ANG327	G310	BR332			FIELD	1	5/8	1 3/4	B-1
AF-2	G310	ANG327	G310	BR332			FIELD	1	5/8	1 3/4	B-1
AF-2	G310	BR332	G310	BR332			FIELD	1	5/8	1 3/4	B-1
AF-2	G310	ANG327	G310	BR332			FIELD	1	5/8	1 3/4	B-1
AF-2	G310	ANG327	G310	BR332			FIELD	1	5/8	1 3/4	B-1
AF-2	G310	ANG327	G310	BR332			FIELD	1	5/8	1 3/4	B-1
AF-2	G310	ANG327	G310	BR332			FIELD	1	5/8	1 3/4	B-1
AF-2	G310	BR332	G310	BR332			FIELD	1	5/8	1 3/4	B-1
AF-2	G310	ANG327	G310	BR332			FIELD	1	5/8	1 3/4	B-1
AF-2	G310	ANG327	G310	BR332			FIELD	1	5/8	1 3/4	B-1
AF-2	G310	ANG327	G310	BR332			FIELD	1	5/8	1 3/4	B-1
AF-2	G310	ANG327	G310	BR332			FIELD	1	5/8	1 3/4	B-1
AF-2	G310	ANG327	G310	BR332			FIELD	1	5/8	1 3/4	B-1
AF-2	G310	BR332	G310	BR332			FIELD	1	5/8	1 3/4	B-1
AF-5	G301	C340	G301	C341			FIELD	4	5/8	1 3/4	B-1
AF-5	G301	C340	G301	C341			FIELD	4	5/8	1 3/4	B-1
AF-5	G301	C340	G301	C341			FIELD	4	5/8	1 3/4	B-1
AF-5	G301	C340	G301	C341			FIELD	4	5/8	1 3/4	B-1
AF-5	G301	C340	G301	C341			FIELD	4	5/8	1 3/4	B-1
AF-2; AF-5	G310	ANG310	G301	CH301			FIELD	2	5/8	1 3/4	B-1
AF-2; AF-5	G310	ANG310	G301	CH301			FIELD	2	5/8	1 3/4	B-1
AF-2; AF-5	G310	ANG310	G301	CH301			FIELD	2	5/8	1 3/4	B-1
AF-2; AF-5	G310	ANG310	G301	CH301			FIELD	2	5/8	1 3/4	B-1
AF-2; AF-5	G310	ANG310	G301	CH301			FIELD	2	5/8	1 3/4	B-1
AF-2; AF-5	G310	ANG310	G301	CH301			FIELD	2	5/8	1 3/4	B-1
AF-2; AF-5	G310	ANG310	G301	CH301			FIELD	2	5/8	1 3/4	B-1



PRELIMINARY -  
DO NOT USE FOR  
CONSTRUCTION

© 05/2023

NO.	ISSUED FOR BID	REVISIONS	ENG.	DATE
A			VK	06/10/2023

PROJECT NAME: CUMBERLAND ROAD  
69 TO 15 X 25 KV  
SUBSTATION

DRAWING TITLE: BOLT SCHEDULE

DRAWN BY:	DJD
CHECKED BY:	VK
APPROVED BY:	VK
DATE:	05/10/2023
SCALE:	N.T.S.
FILE NUMBER:	12510
SHEET:	

**BOLT SCHEDULE FOR A-FRAME (CONT.)**

REFERENCE DRAWING	GROUP 1	MEMBER 1	GROUP 2	MEMBER 2	GROUP 3	MEMBER 3	SHOP/FIELD	BOLT QUANTITY	BOLT DIAMETER (in.)	BOLT LENGTH (in.)	BOLT NUMBER
AF-2; AF-5	G310	ANG310	G301	CH301			FIELD	2	5/8	1 3/4	B-1
AF-2; AF-5	G310	ANG310	G301	CH301			FIELD	2	5/8	1 3/4	B-1
AF-2; AF-5	G310	ANG310	G301	CH301			FIELD	2	5/8	1 3/4	B-1
AF-2; AF-5	G310	ANG310	G301	CH301			FIELD	2	5/8	1 3/4	B-1
AF-2; AF-5	G310	ANG310	G301	CH301			FIELD	2	5/8	1 3/4	B-1
AF-2; AF-5	G310	ANG310		ANG342			FIELD	2	5/8	2	B-2
AF-2; AF-5	G310	ANG310		ANG342			FIELD	2	5/8	2	B-2
AF-2; AF-5	G310	ANG310		ANG342			FIELD	2	5/8	2	B-2
AF-2; AF-5	G310	ANG310		ANG342			FIELD	2	5/8	2	B-2
AF-2; AF-5	G310	ANG310		ANG344			FIELD	2	5/8	2	B-2
AF-2; AF-5	G310	ANG310		ANG344			FIELD	2	5/8	2	B-2
AF-2; AF-5	G310	ANG310		ANG344			FIELD	2	5/8	2	B-2
AF-2; AF-5	G310	ANG310		ANG344			FIELD	2	5/8	2	B-2
AF-2; AF-7		C312		ANG342			FIELD	4	5/8	2 1/4	B-3
AF-2; AF-7		C312		ANG342			FIELD	4	5/8	2 1/4	B-3
AF-2; AF-7		C312		ANG342			FIELD	4	5/8	2 1/4	B-3
AF-2; AF-7		C312		ANG342			FIELD	4	5/8	2 1/4	B-3
AF-2; AF-7		C312		ANG344			FIELD	4	5/8	2 1/4	B-3
AF-2; AF-7		C312		ANG344			FIELD	4	5/8	2 1/4	B-3
AF-2; AF-7		C312		ANG344			FIELD	4	5/8	2 1/4	B-3
AF-2; AF-7		C312		ANG344			FIELD	4	5/8	2 1/4	B-3
AF-7; AF-8		C312	G303	PL319			FIELD	4	5/8	2	B-2
AF-7; AF-8		C312	G303	PL319			FIELD	4	5/8	2	B-2
AF-7; AF-8		C312	G303	PL319			FIELD	4	5/8	2	B-2
AF-7; AF-8		C312	G303	PL319			FIELD	4	5/8	2	B-2
AF-7; AF-8		C312	G305	PL319			FIELD	4	5/8	2	B-2
AF-7; AF-8		C312	G305	PL319			FIELD	4	5/8	2	B-2
AF-7; AF-8		C312	G305	PL319			FIELD	4	5/8	2	B-2
AF-7; AF-8		C312	G305	PL319			FIELD	4	5/8	2	B-2
AF-1; AF-7		C312	G311	PL350			FIELD	4	5/8	2 1/4	B-3
AF-1; AF-3; AF-7		C312	G311	PL350	G308	ANG326	FIELD	4	5/8	2 3/4	B-5
AF-1; AF-7		C312	G311	PL350			FIELD	4	5/8	2 1/4	B-3
AF-1; AF-3; AF-7		C312	G311	PL350	G308	ANG326	FIELD	4	5/8	2 3/4	B-5
AF-1; AF-7		C312	G311	PL350			FIELD	4	5/8	2 1/4	B-3
AF-1; AF-3; AF-7		C312	G311	PL350	G308	ANG326	FIELD	4	5/8	2 3/4	B-5
AF-7		C312		PL351			FIELD	2	5/8	2 1/4	B-3
AF-7; AF-8		C312		PL351		ANG328	FIELD	2	5/8	2 3/4	B-5
AF-3; AF-7		C312		PL351	G308	ANG326	FIELD	4	5/8	2 3/4	B-5



**PRELIMINARY -  
DO NOT USE FOR  
CONSTRUCTION**

© 05/2023

NO.	ISSUED FOR BID	REVISIONS	ENG.	DATE
A			VK	06/10/2023

PROJECT NAME: CUMBERLAND ROAD  
69 TO 15 X 25 KV  
SUBSTATION

DRAWING TITLE:  
**BOLT SCHEDULE**

DRAWN BY:	DJD
CHECKED BY:	VK
APPROVED BY:	VK
DATE:	05/10/2023
SCALE:	N.T.S.
FILE NUMBER:	12510
SHEET:	

**BOLT SCHEDULE FOR A-FRAME (CONT.)**

REFERENCE DRAWING	GROUP 1	MEMBER 1	GROUP 2	MEMBER 2	GROUP 3	MEMBER 3	SHOP/FIELD	BOLT QUANTITY	BOLT DIAMETER (in.)	BOLT LENGTH (in.)	BOLT NUMBER
AF-7		C312		PL351			FIELD	2	5/8	2 1/4	B-3
AF-7; AF-8		C312		PL351		ANG328	FIELD	2	5/8	2 3/4	B-5
AF-3; AF-7		C312		PL351	G308	ANG326	FIELD	4	5/8	2 3/4	B-5
AF-7		C312		PL351			FIELD	4	5/8	2 1/4	B-3
AF-3; AF-7		C312		PL351	G308	ANG326	FIELD	4	5/8	2 3/4	B-5
AF-7		C312		PL351			FIELD	4	5/8	2 1/4	B-3
AF-3; AF-7		C312		PL351	G308	ANG326	FIELD	4	5/8	2 3/4	B-5
AF-3	G308	PL322	G308	ANG326			FIELD	3	5/8	2 1/2	B-4
AF-3	G308	PL322	G308	ANG326			FIELD	3	5/8	2 1/2	B-4
AF-3	G308	PL322	G308	ANG326			FIELD	3	5/8	2 1/2	B-4
AF-3	G308	PL322	G308	ANG326			FIELD	3	5/8	2 1/2	B-4
AF-3	G309	PL321	G308	PL325			FIELD	4	5/8	2 1/4	B-3
AF-3	G309	PL321	G308	PL325			FIELD	4	5/8	2 1/4	B-3
AF-5; AF-6	G302	CH302	G301	CH301			FIELD	4	5/8	3 1/2	B-6
AF-2; AF-6	G302	CH302	G310	ANG310			FIELD	4	5/8	3 1/2	B-6
AF-5; AF-6	G302	CH302	G301	CH301			FIELD	4	5/8	3 1/2	B-6
AF-5; AF-6	G302	CH302	G301	CH301			FIELD	4	5/8	3 1/2	B-6
AF-2; AF-6	G302	CH302	G310	ANG310			FIELD	4	5/8	3 1/2	B-6
AF-5; AF-6	G302	CH302	G301	CH301			FIELD	4	5/8	3 1/2	B-6
AF-5; AF-6	G302	CH302	G301	CH301			FIELD	4	5/8	3 1/2	B-6
AF-2; AF-6	G302	CH302	G310	ANG310			FIELD	4	5/8	3 1/2	B-6
AF-5; AF-6	G302	CH302	G301	CH301			FIELD	4	5/8	3 1/2	B-6



**Booth & Associates**  
2309 Rawwood Drive Suite 300, Raleigh, NC 27607  
 N.C. F. 0221



**PRELIMINARY -  
 DO NOT USE FOR  
 CONSTRUCTION**

© 05/2023

NO.	ISSUED FOR BID	REVISIONS	ENG.	DATE
A			VK	06/10/2023

PROJECT NAME: **CUMBERLAND ROAD  
 69 TO 15 X 25 KV  
 SUBSTATION**

DRAWING TITLE: **BOLT SCHEDULE**



DRAWN BY:	DJD
CHECKED BY:	VK
APPROVED BY:	VK
DATE:	05/10/2023
SCALE:	N.T.S.
FILE NUMBER:	12510
SHEET:	





**BOLT SCHEDULE FOR LOW SWITCH STAND (CONT.)**

REFERENCE DRAWING	GROUP 1	MEMBER 1	GROUP 2	MEMBER 2	GROUP 3	MEMBER 3	SHOP/FIELD	BOLT QUANTITY	BOLT DIAMETER (in.)	BOLT LENGTH (in.)	BOLT NUMBER
SS-1; SS-5	G401	PL416	G400	PL416			FIELD	4	5/8	2 1/4	B-3
SS-1; SS-5; SS-6	G401	ANG408	G400	ANG413			FIELD	1	5/8	1 3/4	B-1
SS-1; SS-5; SS-6	G401	ANG408	G400	ANG413			FIELD	1	5/8	1 3/4	B-1
SS-5; SS-6	G401	ANG408	G401	ANG413			FIELD	1	5/8	1 3/4	B-1
SS-5; SS-6	G401	ANG408	G401	ANG413			FIELD	1	5/8	1 3/4	B-1
SS-2; SS-5	G401	PL416	G400.1	PL416			FIELD	4	5/8	2 1/4	B-3
SS-1; SS-5	G401	ANG408	G400.1	ANG413			FIELD	1	5/8	1 3/4	B-1
SS-1; SS-5	G401	ANG408	G400.1	ANG413			FIELD	1	5/8	1 3/4	B-1
SS-5; SS-6	G401	ANG408	G401	ANG413			FIELD	1	5/8	1 3/4	B-1
SS-5; SS-6	G401	ANG408	G401	ANG413			FIELD	1	5/8	1 3/4	B-1

PRELIMINARY - DO NOT USE FOR CONSTRUCTION

© 05 / 2023

NO.	ISSUED FOR BID	REVISIONS	ENG.	DATE
A			VK	06/10/2023

PROJECT NAME: CUMBERLAND ROAD  
69 TO 15 X 25 KV  
SUBSTATION

DRAWING TITLE: BOLT SCHEDULE

DRAWN BY: DJD

CHECKED BY: VK

APPROVED BY: VK

DATE: 05/10/2023

SCALE: N.T.S.

FILE NUMBER: 12510

SHEET:

BS-17



**BOLT SCHEDULE FOR HIGH SWTCH STAND (CONT.)**

REFERENCE DRAWNG	GROUP 1	MEMBER 1	GROUP 2	MEMBER 2	GROUP 3	MEMBER 3	SHOP/FIELD	BOLT QUANTITY	BOLT DIAMETER (in.)	BOLT LENGTH (in.)	BOLT NUMBER
SS-1; SS-5	G401	PL416	G450	PL416			FIELD	4	5/8	2 1/4	B-3
SS-1; SS-5; SS-6	G401	ANG408	G450	ANG413			FIELD	1	5/8	1 3/4	B-1
SS-1; SS-5; SS-6	G401	ANG408	G450	ANG413			FIELD	1	5/8	1 3/4	B-1
SS-5; SS-6	G401	ANG408	G401	ANG413			FIELD	1	5/8	1 3/4	B-1
SS-5; SS-6	G401	ANG408	G401	ANG413			FIELD	1	5/8	1 3/4	B-1
SS-2; SS-5	G401	PL416	G450.1	PL416			FIELD	4	5/8	2 1/4	B-3
SS-1; SS-5	G401	ANG408	G450.1	ANG413			FIELD	1	5/8	1 3/4	B-1
SS-1; SS-5	G401	ANG408	G450.1	ANG413			FIELD	1	5/8	1 3/4	B-1
SS-5; SS-6	G401	ANG408	G401	ANG413			FIELD	1	5/8	1 3/4	B-1
SS-5; SS-6	G401	ANG408	G401	ANG413			FIELD	1	5/8	1 3/4	B-1

**BOLT SCHEDULE FOR THREE PHASE BUS STAND**

REFERENCE DRAWNG	GROUP 1	MEMBER 1	GROUP 2	MEMBER 2	GROUP 3	MEMBER 3	SHOP/FIELD	BOLT QUANTITY	BOLT DIAMETER (in.)	BOLT LENGTH (in.)	BOLT NUMBER
TPB-1; TPB-2; TPB-3	G600	PL607	G605	B605			FIELD	8	5/8	2	B-2
TPB-1; TPB-2; TPB-3	G600	PL608	G600	ANG610			FIELD	1	5/8	1 3/4	B-1
TPB-1; TPB-2; TPB-3	G600	PL608	G600	ANG610			FIELD	1	5/8	1 3/4	B-1
TPB-1; TPB-2; TPB-3	G605	PL608	G600	ANG610			FIELD	1	5/8	1 3/4	B-1
TPB-1; TPB-2; TPB-3	G605	PL608	G600	ANG610			FIELD	1	5/8	1 3/4	B-1

**BOLT SCHEDULE FOR STATIC POLE**

REFERENCE DRAWNG	GROUP 1	MEMBER 1	GROUP 2	MEMBER 2	GROUP 3	MEMBER 3	SHOP/FIELD	BOLT QUANTITY	BOLT DIAMETER (in.)	BOLT LENGTH (in.)	BOLT NUMBER
SM-1; SM-3; SM-4	G401	PL401	G402	PL402			FIELD	4	1	2 3/4	B-7



**PRELIMINARY - DO NOT USE FOR CONSTRUCTION**

© 05/2023

NO.	ISSUED FOR BID	REVISIONS	ENG.	DATE
A			VK	06/10/2023

PROJECT NAME: CUMBERLAND ROAD 69 TO 15 X 25 KV SUBSTATION  
 DRAWING TITLE: BOLT SCHEDULE

DRAWN BY:	DJD
CHECKED BY:	VK
APPROVED BY:	VK
DATE:	05/10/2023
SCALE:	N.T.S.
FILE NUMBER:	12510
SHEET:	

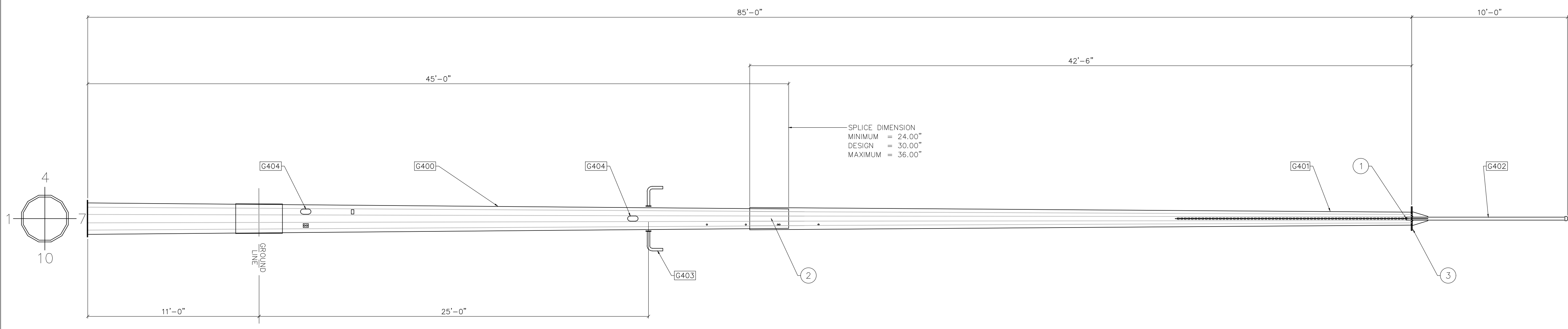

- NOTES:
- 1) SEE TECHNICAL REQUIREMENTS FOR MATERIAL AND FINISH REQUIREMENTS.
  - 2) SEE POLE MANUFACTURER SPECIFICATIONS FOR HANDLING AND ERECTION GUIDELINES.
  - 3) LIGHTING ASSEMBLY TO BE MOUNTED PER POLE MANUFACTURER PROVIDED CONNECTION.
  - 4) SLIP JOINT JACKING FORCE:  
MINIMUM = 10,000 LBS. AT EACH SIDE  
MAXIMUM = PER MANUFACTURER'S SPECIFICATION

BILL OF MATERIAL				
POS. NO.	QTY	DESC.	LENGTH	WEIGHT
G400	1	SECTION ASSEMBLY	45'-0"	2,094.08
G401	1	SECTION ASSEMBLY	42'-6"	1,206.66
G402	1	STATIC MAST ASSEMBLY	10'-0"	84.46
G403	2	LIGHTING ASSEMBLY	-	14.00
G404	3	HANDHOLE ASSEMBLY	-	-
CH402	1	3/8" HDGV CHAIN	25'-0"	36.25
H402	1	2" RUBBER HOSE	25'-0"	-
			BLACK WEIGHT:	3,435.45 LB
			GALVANIZED WEIGHT:	137.42 LB
			TOTAL WEIGHT:	3,572.87 LB

STATIC POLE-ELEVATION  
SCALE: 1/4"=1'-0"

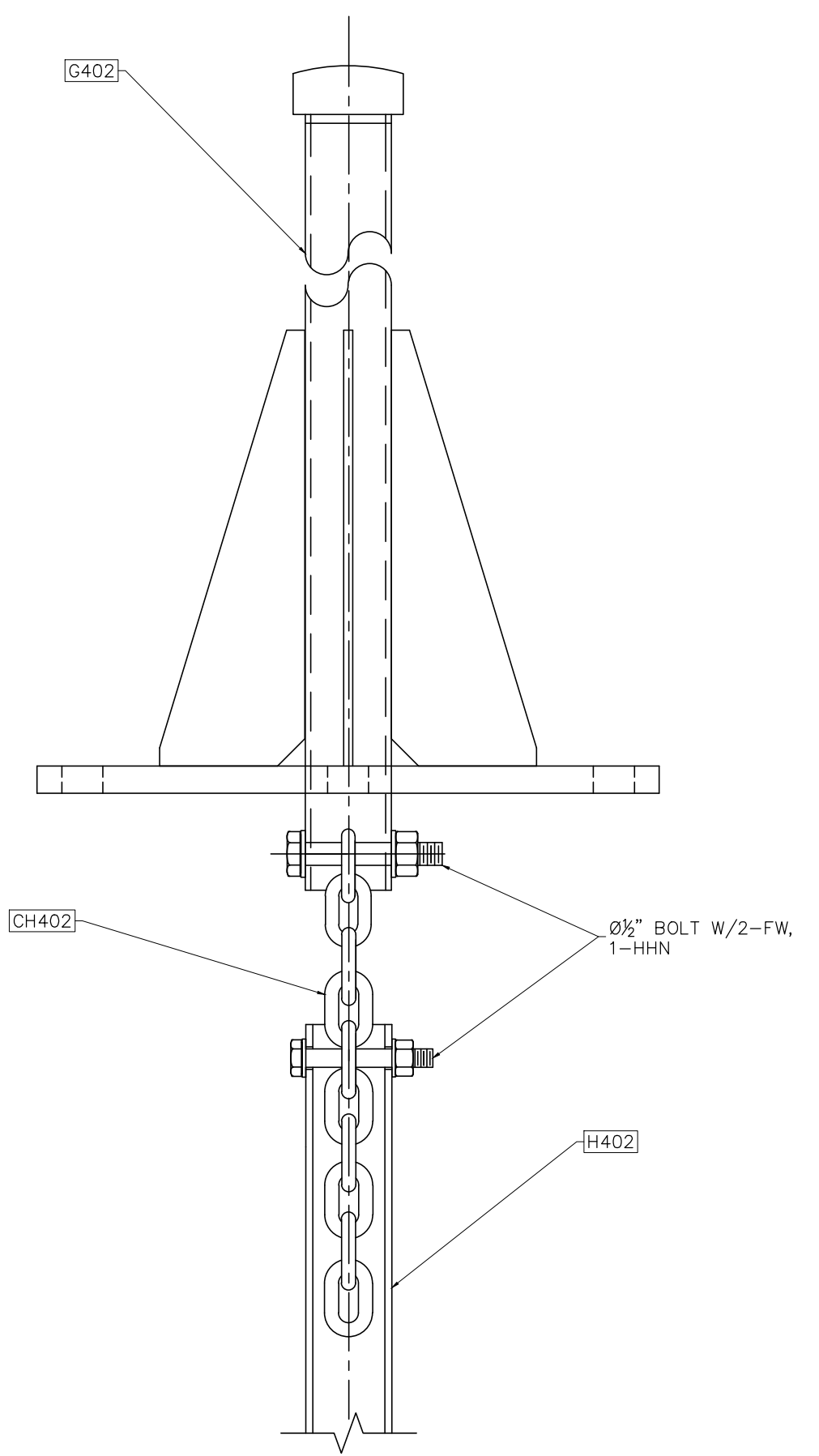

① DAMPING CHAIN CONNECTION  
NOT TO SCALE

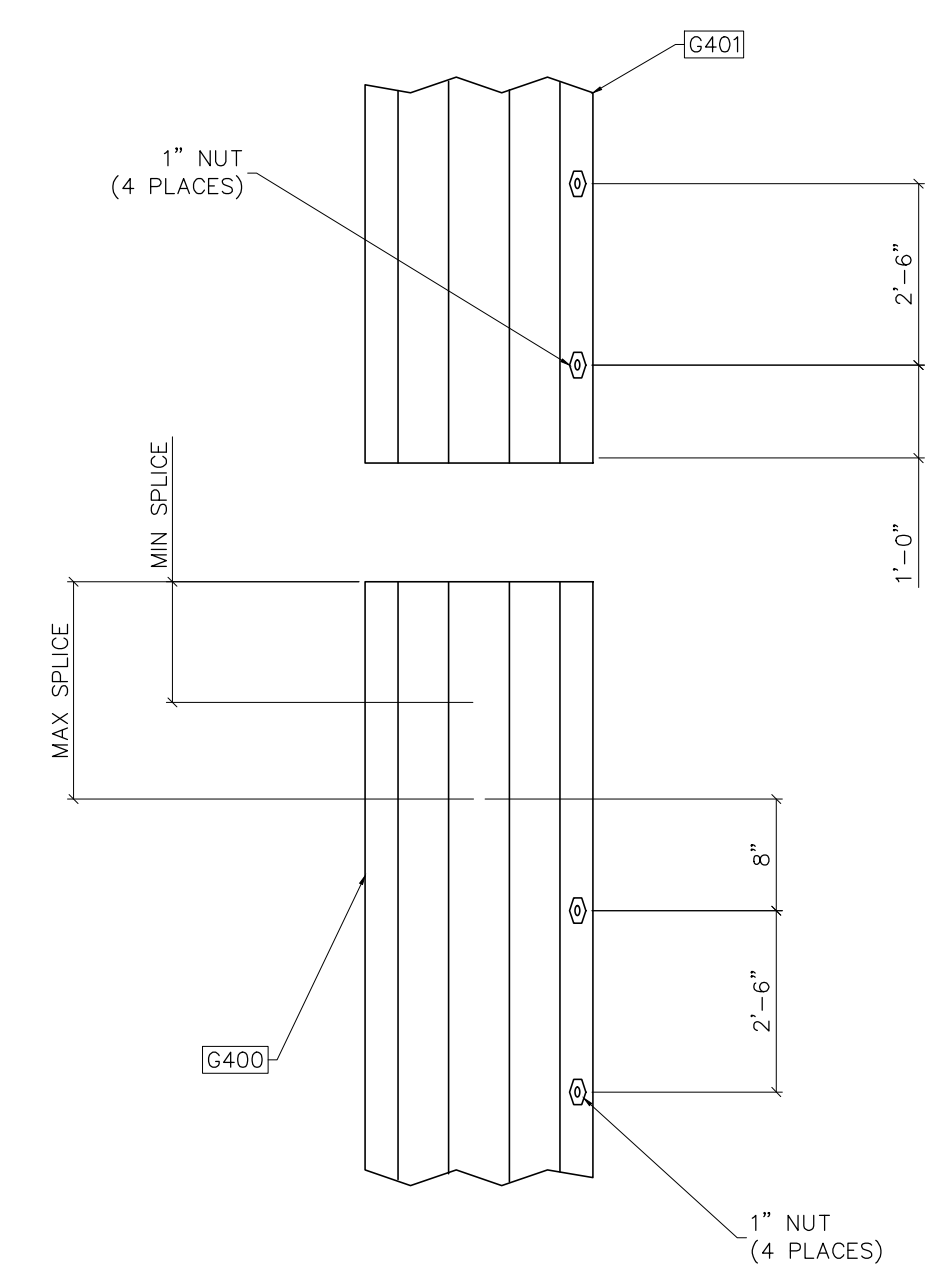

② SLIP JOINT DETAIL  
NOT TO SCALE

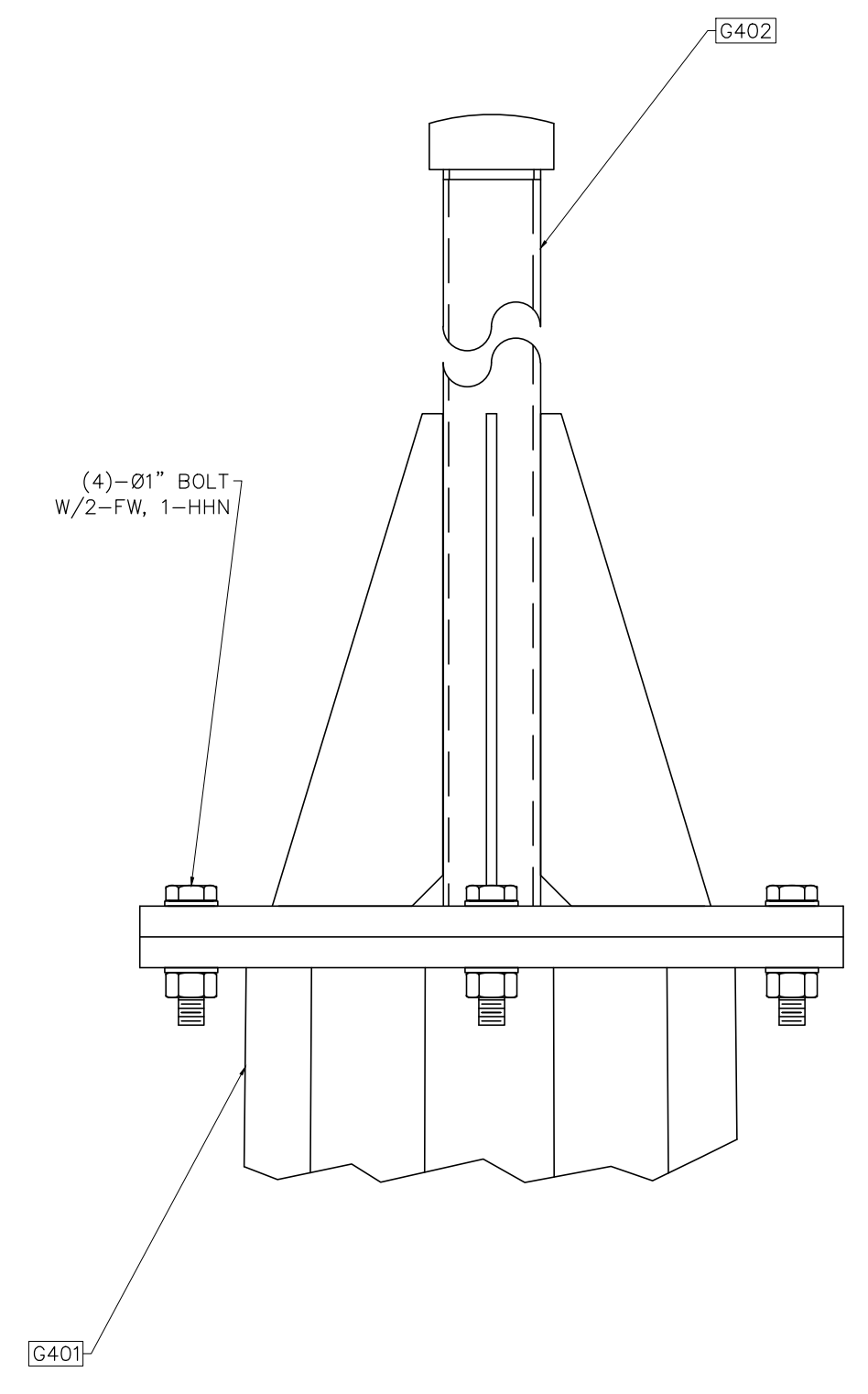

③ POLE CAP CONNECTION  
NOT TO SCALE



Booth & Associates  
2200 Ramwood Drive Suite 300, Raleigh, NC 27607  
NC F 0221



PRELIMINARY -  
DO NOT USE FOR  
CONSTRUCTION

© 05/2023

NO.	ISSUED FOR BID	REVISIONS	ENG.	DATE
A			VK	05/10/2023

PROJECT NAME: CUMBERLAND ROAD  
69 TO 15 X 25 kV  
SUBSTATION

DRAWING TITLE:  
STATIC MAST DETAIL

DRAWN BY:	DJD
CHECKED BY:	VK
APPROVED BY:	VK
DATE:	05/10/2023
SCALE:	AS SHOWN
FILE NUMBER:	12510
SHEET:	

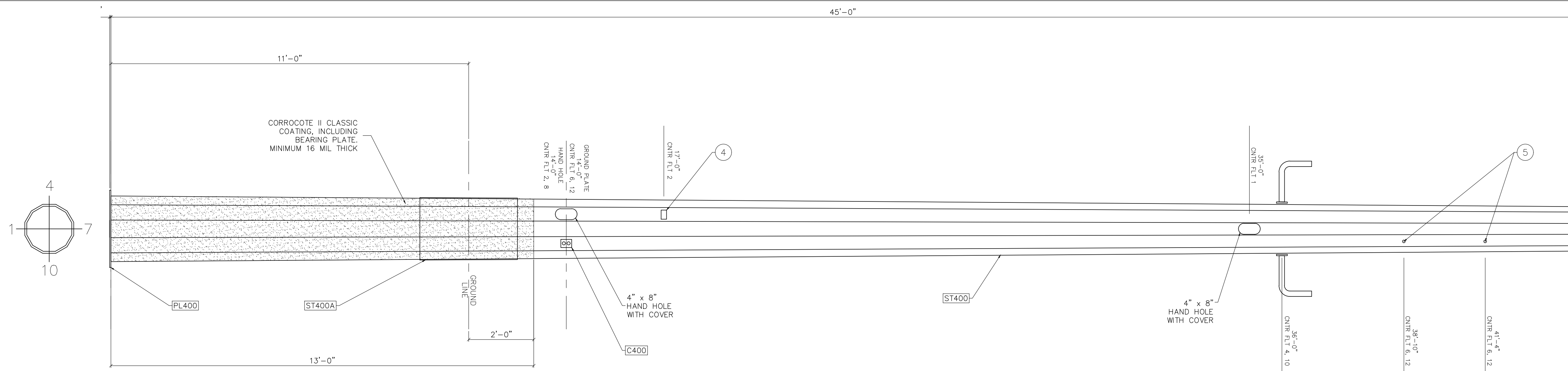

BILL OF MATERIAL					
POS. NO.	ASTM SPEC	QTY	DESC.	LENGTH	WEIGHT
G400	-	1	FOR ONE GROUP 400:	-	-
ST400	A572-GR65	1	SHAFT	45'-0"	1,847.00
ST400A	A572-GR65	1	3/8" GROUND SLEEVE	3'-0"	153.00
PL400	A36	1	PL 1/2" X 82'-4 3/8"	-	91.38
C400	A36	2	C 4 X 5.4	3"	2.70
				BLACK WEIGHT:	2,094.08 LB
				GALVANIZED WEIGHT:	83.76 LB
				TOTAL WEIGHT:	2,177.84 LB

SHAFT INFO (MEASURED ACROSS FLATS)					
SHAPE	LENGTH	BASE O.D.	TOP O.D.	TAPER	THK
12-SIDED	45'-0"	24.00"	16.39"	0.16912"	.188"
					ASTM
					A572-GR65

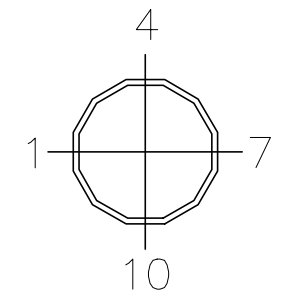

G400-ELEVATION  
SCALE: 1/2"=1'-0"

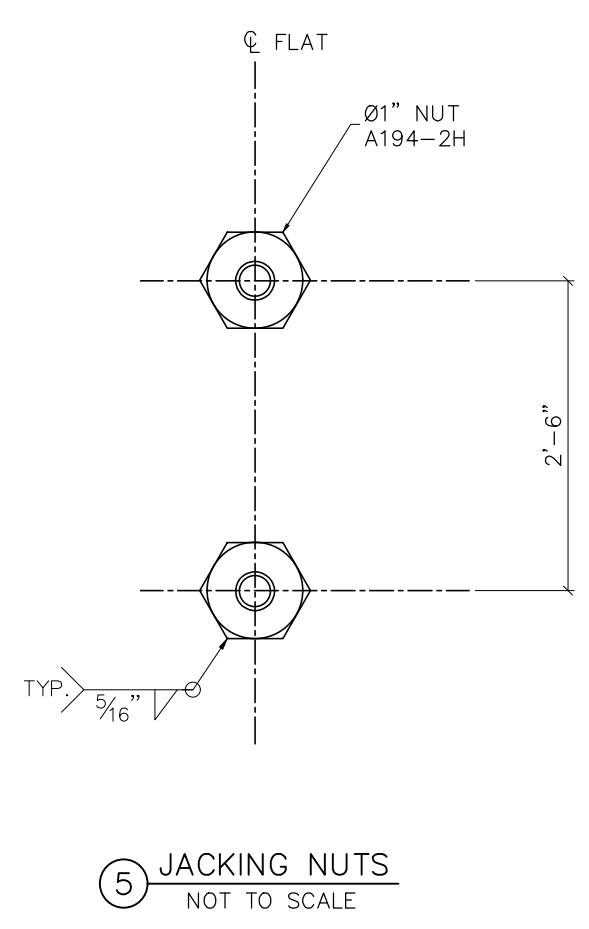
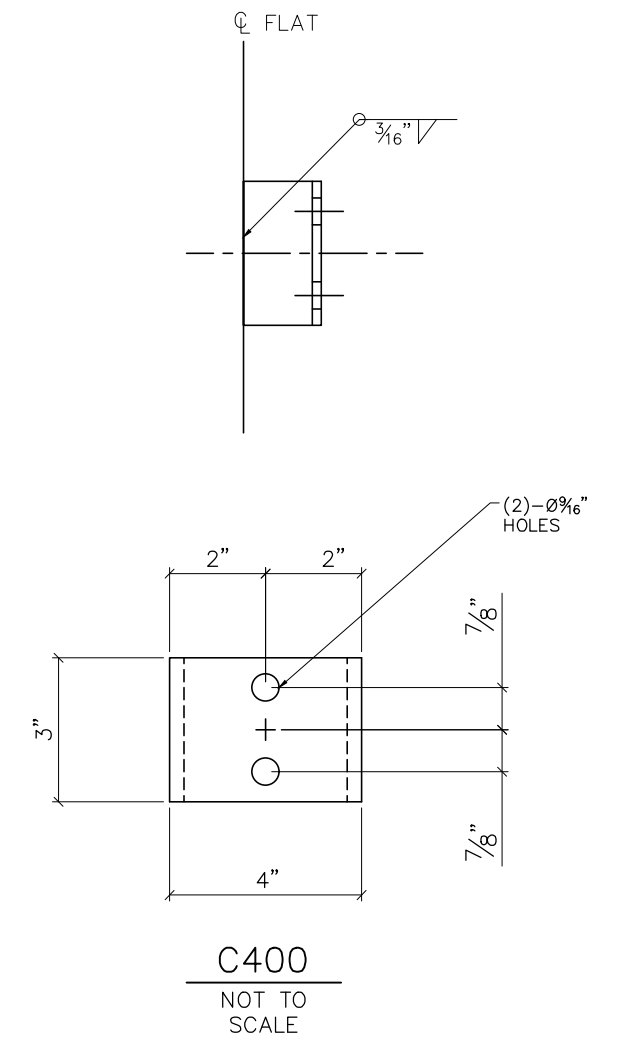
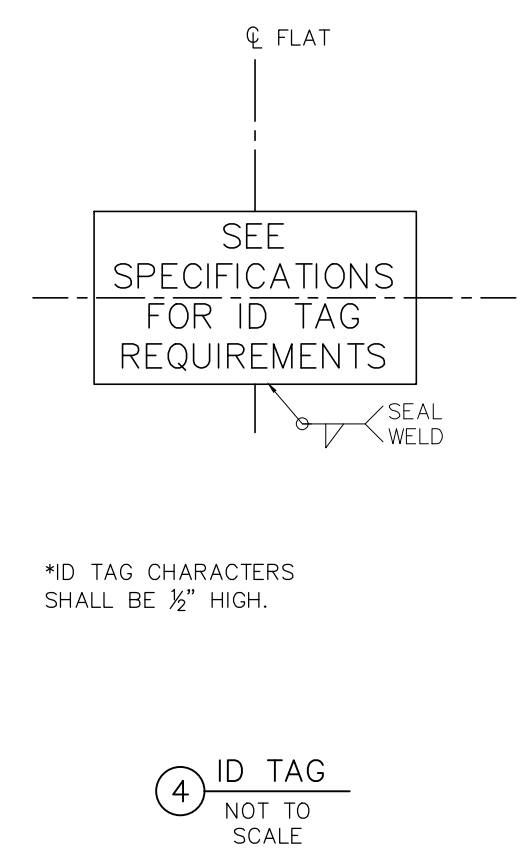
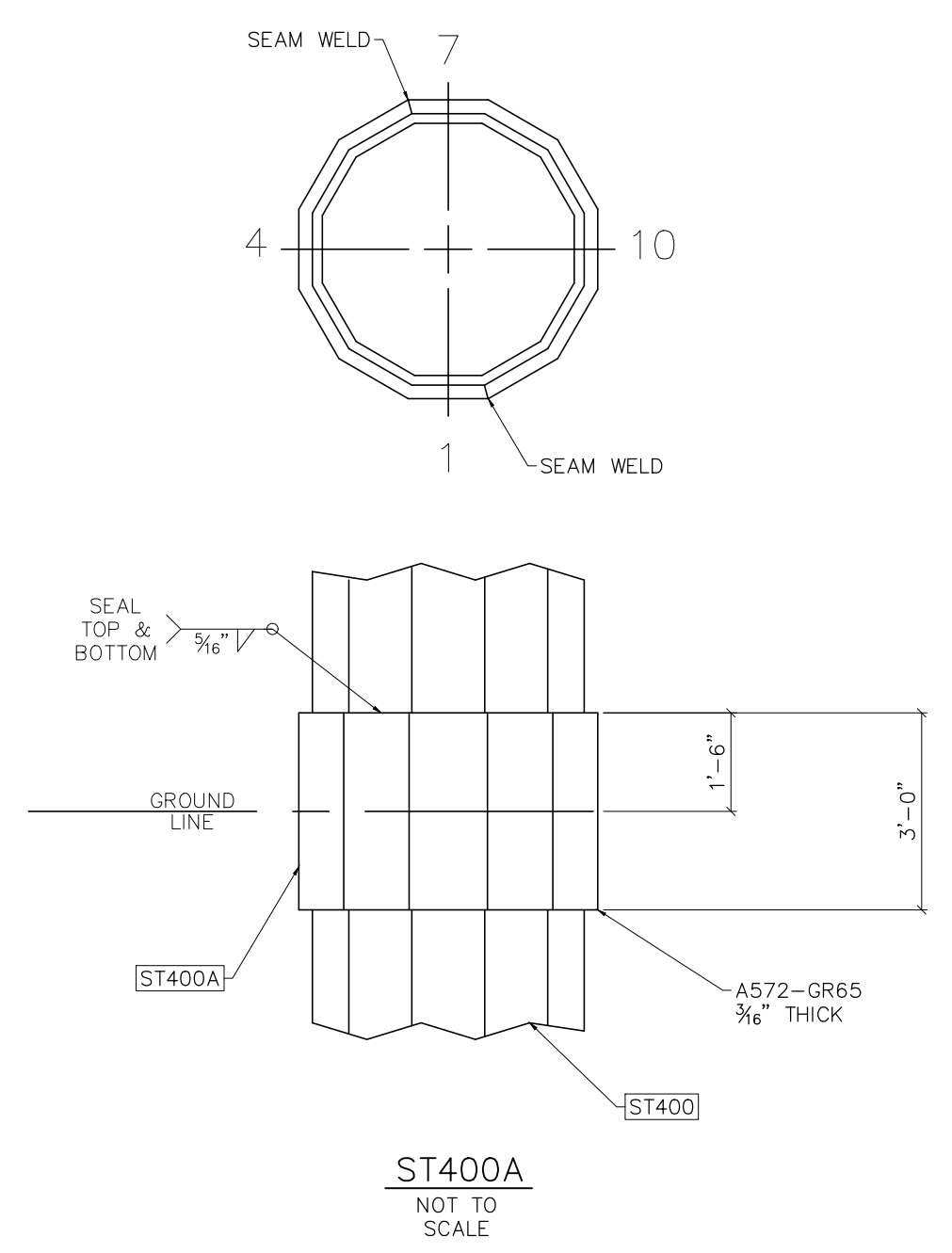
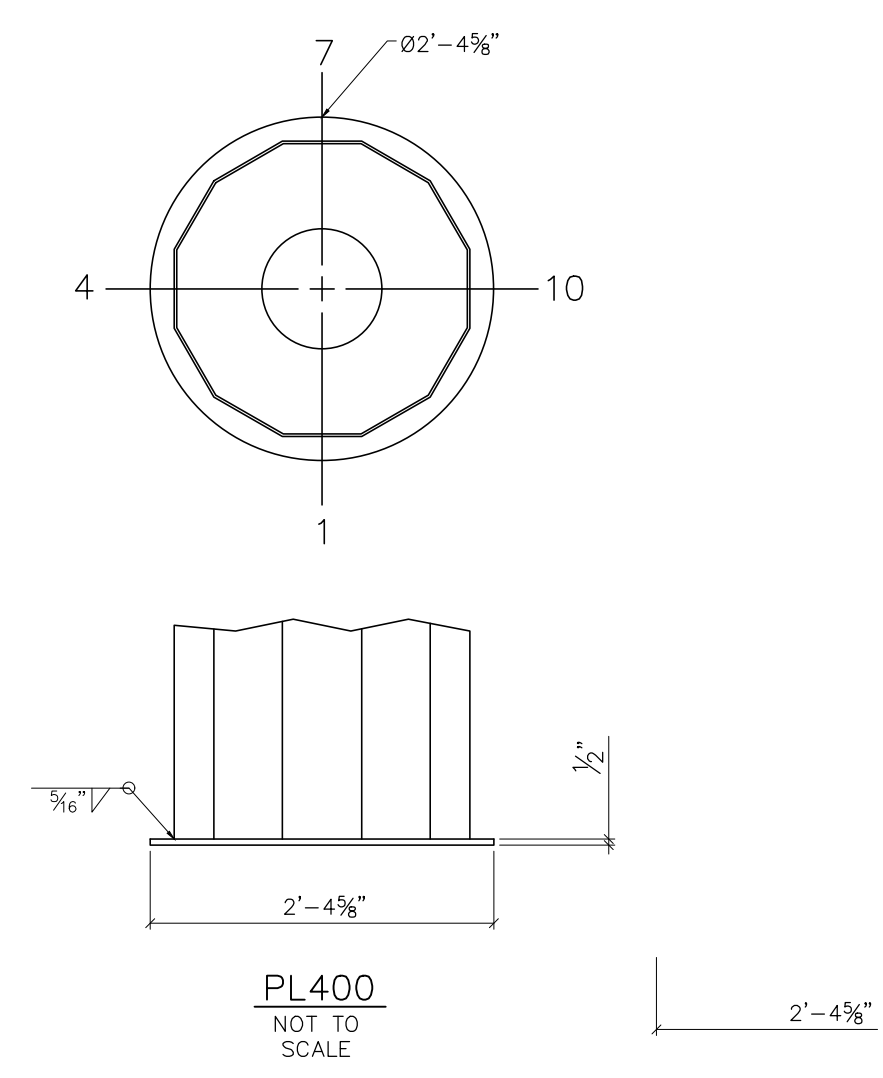

PRELIMINARY -  
DO NOT USE FOR  
CONSTRUCTION

© 05/2023

NO.	REVISIONS	DATE	ENG.	ISSUED FOR BID	
				DATE	BY
A		06/10/2023	VK		

PROJECT NAME:  
CUMBERLAND ROAD  
69 TO 15 X 25 kV  
SUBSTATION

DRAWING TITLE:  
STATIC MAST DETAIL

DRAWN BY:	DJD
CHECKED BY:	VK
APPROVED BY:	VK
DATE:	05/10/2023
SCALE:	AS SHOWN
FILE NUMBER:	12510
SHEET:	

BILL OF MATERIAL					
POS. NO.	ASTM SPEC	QTY	DESC.	LENGTH	WEIGHT
G401	-	1	FOR ONE GROUP 401:	-	-
ST401	A572-GR65	1	SHAFT	42'-6"	1,169.00
PL401	A572-GR65	1	PL 1/2" X 01'-6 3/8"	-	48.27
BLACK WEIGHT:					1,206.66 LB
GALVANIZED WEIGHT:					48.27 LB
TOTAL WEIGHT:					1,254.93 LB

SHAFT INFO (MEASURED ACROSS FLATS)						
SHAPE	LENGTH	BASE O.D.	TOP O.D.	TAPER	THK	ASTM
12-SIDED	42'-6"	17.19"	10.00"	0.16912"	.188"	A572-GR65

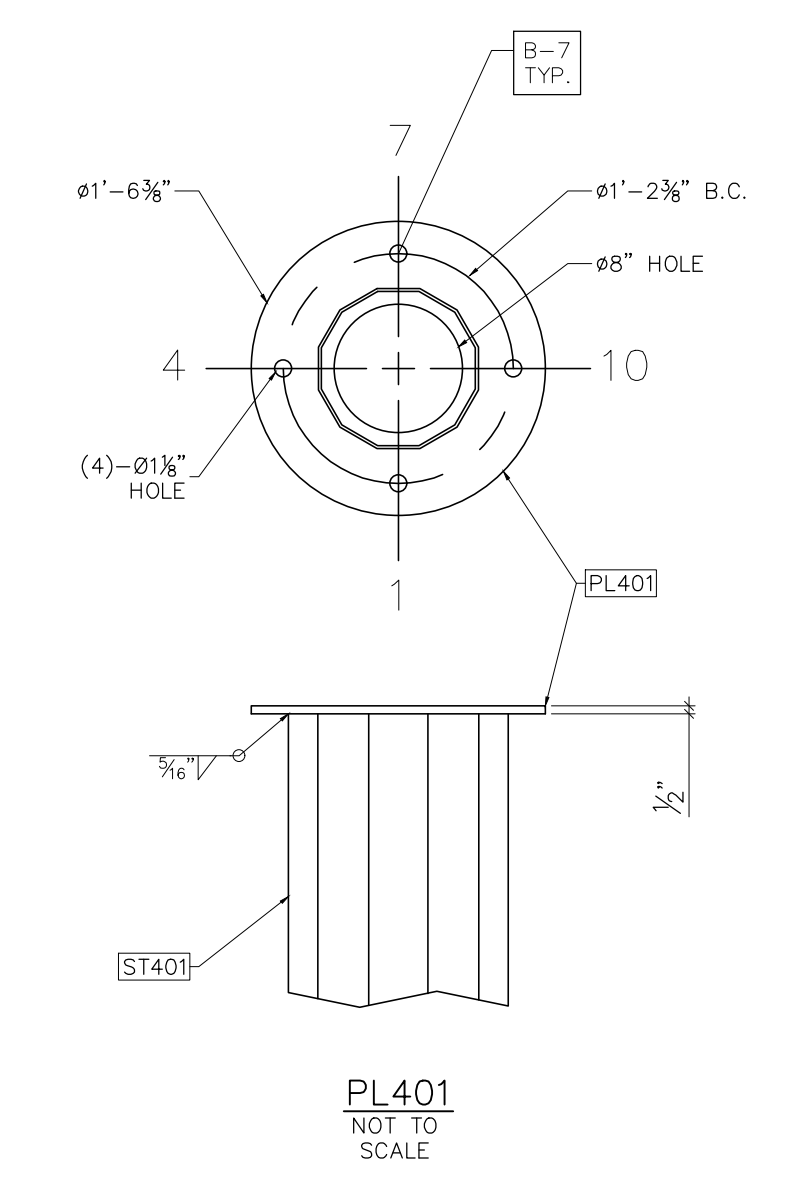
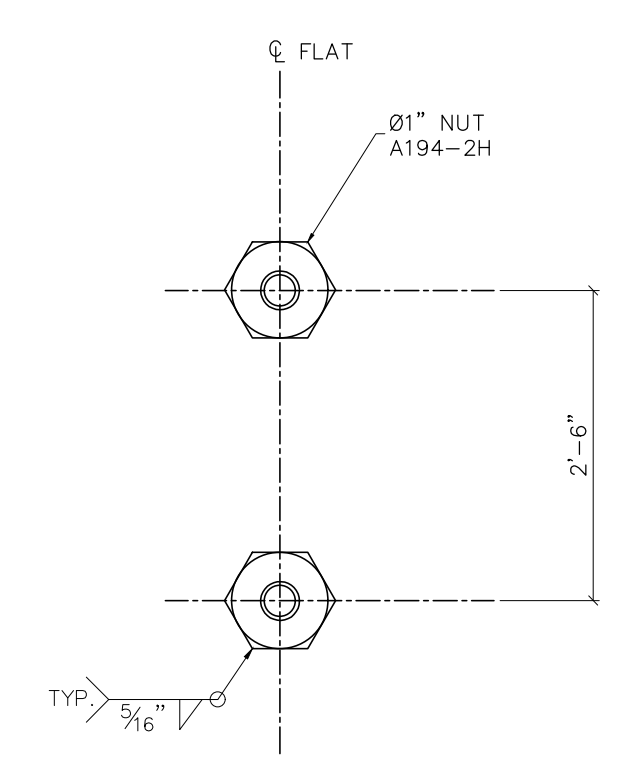
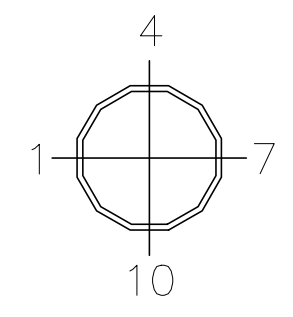
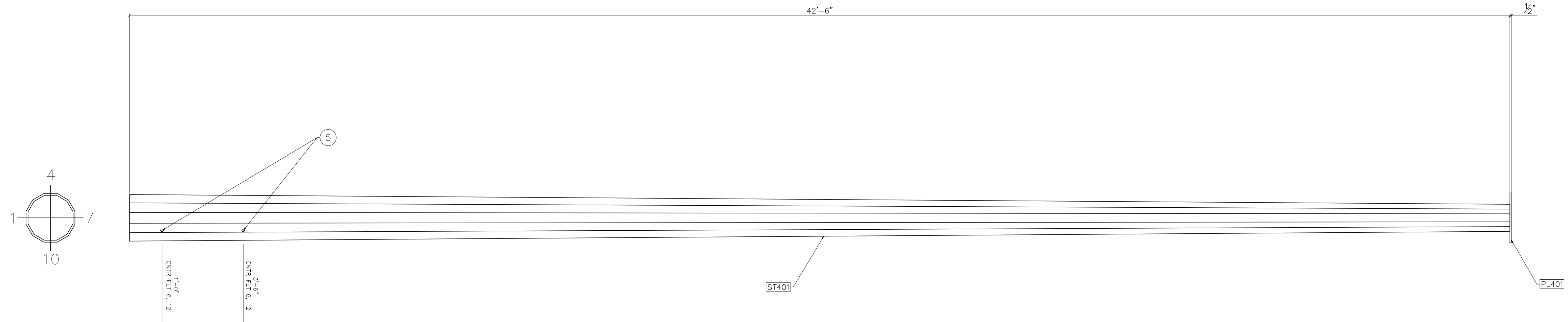

G401-ELEVATION  
SCALE: 1/2"=1'-0"

5 JACKING NUTS  
NOT TO SCALE

PL401  
NOT TO SCALE



PRELIMINARY -  
DO NOT USE FOR  
CONSTRUCTION

© 05/2023

NO.	ISSUED FOR BID	REVISIONS	ENG.	DATE
A			VK	06/10/2023

PROJECT NAME: CUMBERLAND ROAD  
69 TO 15 X 25 kV  
SUBSTATION

DRAWING TITLE: STATIC MAST DETAIL

DRAWN BY:	DJD
CHECKED BY:	VK
APPROVED BY:	VK
DATE:	05/10/2023
SCALE:	AS SHOWN
FILE NUMBER:	12510
SHEET:	

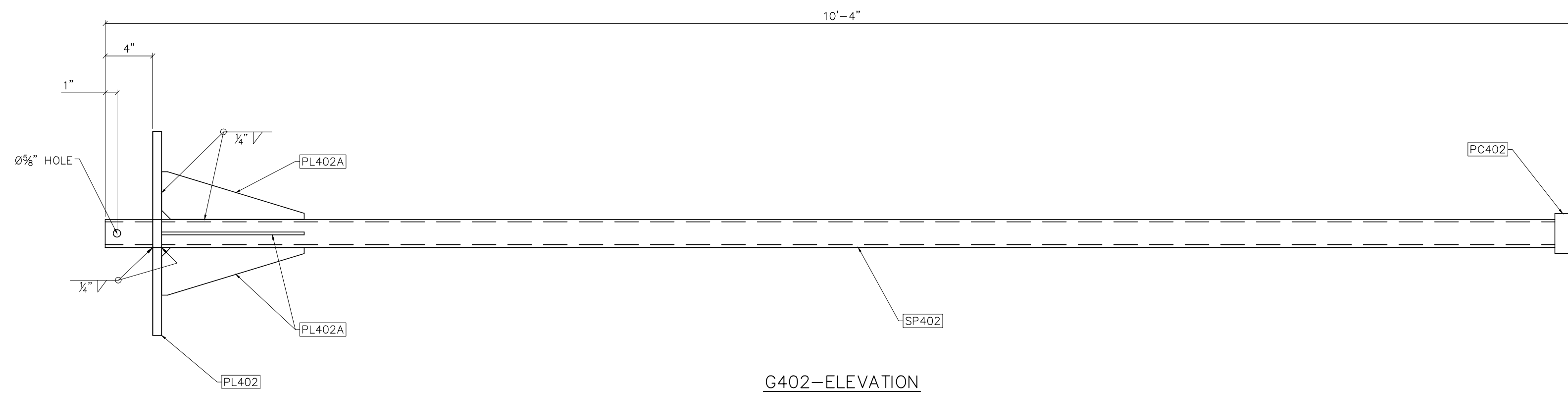

**G402-ELEVATION**  
SCALE: 1-1/2"=1'-0"

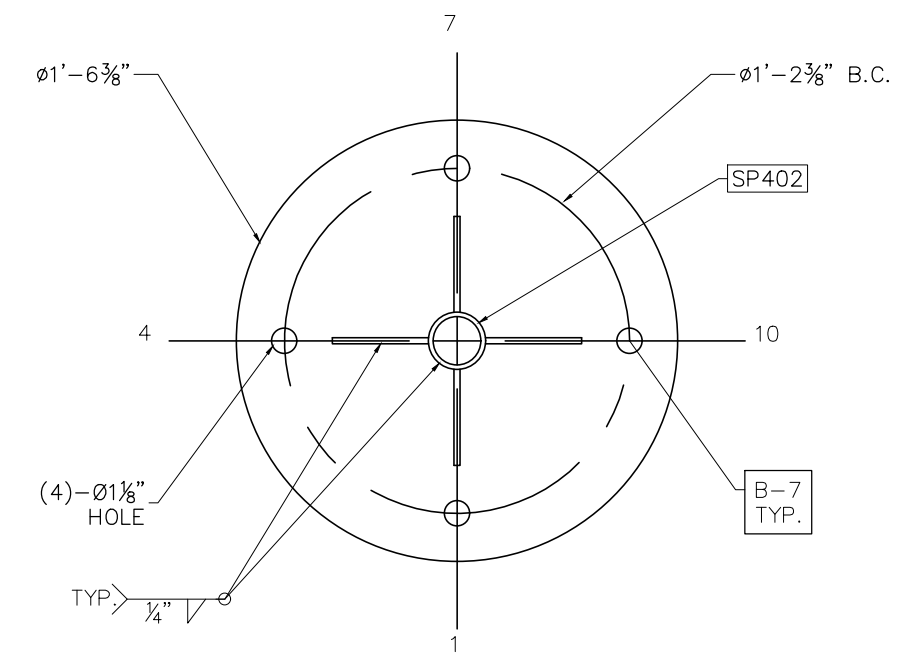

**PL402**  
NOT TO SCALE

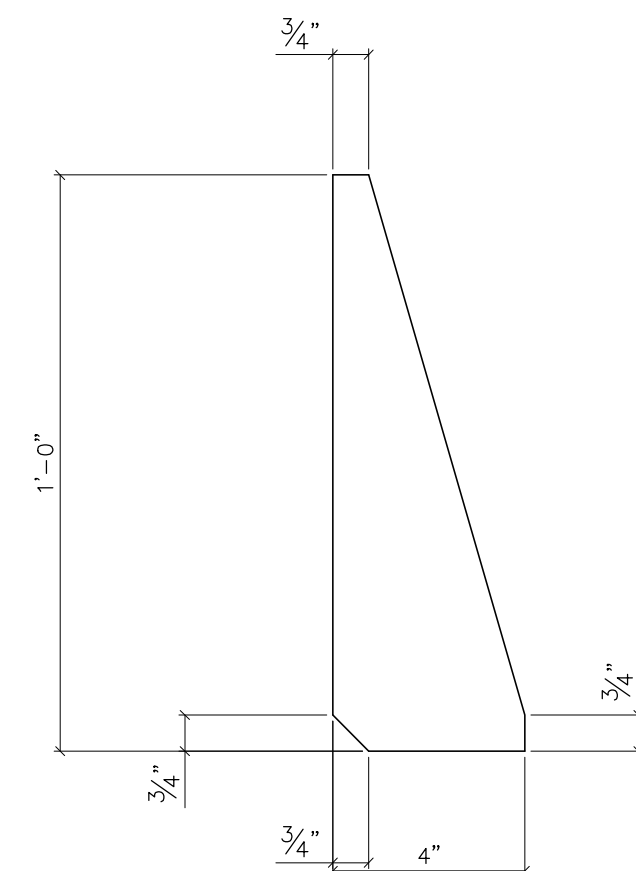

**PL402A**  
NOT TO SCALE

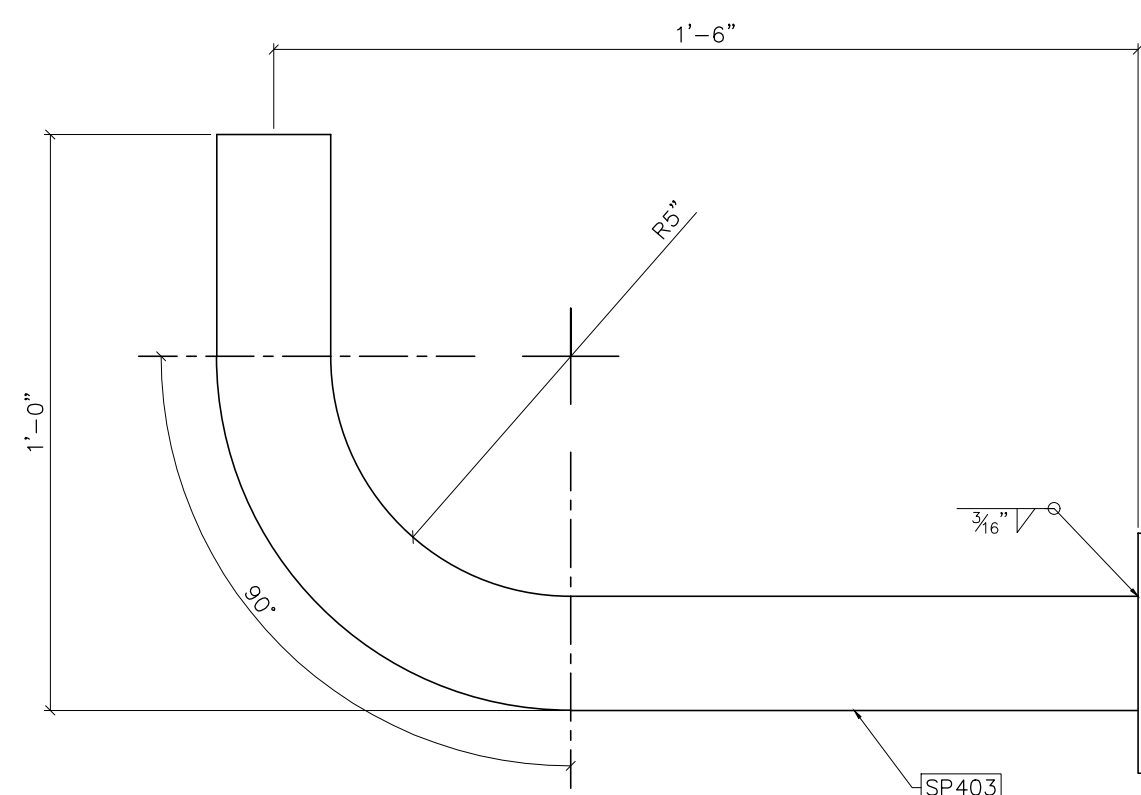

**G403-SIDE VIEW**  
NOT TO SCALE

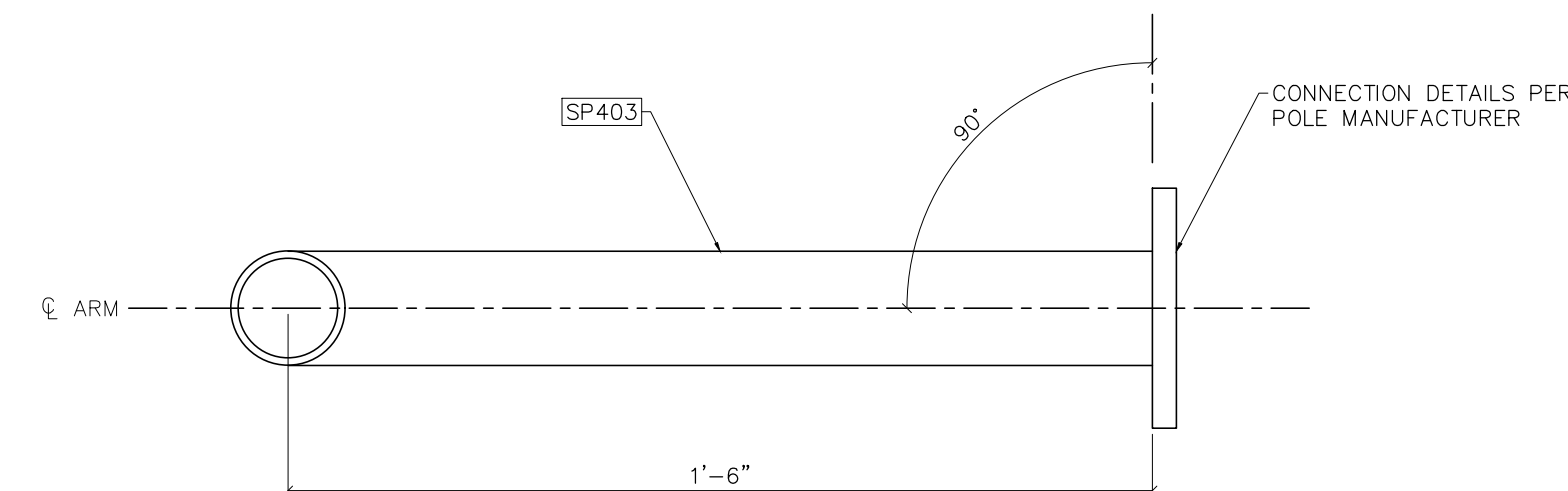

**G403-TOP VIEW**  
NOT TO SCALE

BILL OF MATERIAL					
POS. NO.	ASTM GRADE	QTY	DESC.	LENGTH	WEIGHT
G402	-	1	FOR ONE GROUP 402:	-	-
SP402	A53	1	PIPE 2" STD	10'-4"	37.74
PL402	A36	1	PL 1/2" X 01'-6 3/8"	-	37.66
PL402A	A36	4	PL 1/2" X 4" (HALF)	1'-0"	7.88
PC402	A53	1	2" SCH 40 GV CAP	-	1.18
BLACK WEIGHT:					84.46 LB
GALVANIZED WEIGHT:					3.38 LB
TOTAL WEIGHT:					87.84 LB

BILL OF MATERIAL					
POS. NO.	ASTM GRADE	QTY	DESC.	LENGTH	WEIGHT
G403	-	2	FOR ONE GROUP 403:	-	-
SP403	A53	1	2" SCH 40 GV PIPE	1'-11"	14.00
BLACK WEIGHT:					14.00 LB
GALVANIZED WEIGHT:					0.56 LB
TOTAL WEIGHT:					14.56 LB

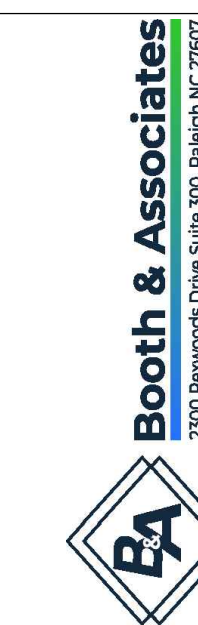

PRELIMINARY -  
DO NOT USE FOR  
CONSTRUCTION

© 05/2023

NO.	ISSUED FOR BID	REVISIONS	ENG.	DATE
A				06/10/2023

PROJECT NAME:	CUMBERLAND ROAD 69 TO 15 X 25 kV SUBSTATION
DRAWING TITLE:	STATIC MAST DETAIL
DRAWN BY:	DJD
CHECKED BY:	VK
APPROVED BY:	VK
DATE:	05/10/2023
SCALE:	AS SHOWN
FILE NUMBER:	12510
SHEET:	SM-4

**PUBLIC WORKS COMMISSION OF THE CITY OF FAYETTEVILLE  
FAYETTEVILLE, NORTH CAROLINA**

**STRUCTURES AND EQUIPMENT FOR THE  
CUMBERLAND ROAD 69 TO 25 x 15 KV SUBSTATION**

**BILL OF MATERIAL**

6/6/2022

ITEM NO.	DESCRIPTION	QUANTITY	MANUFACTURER	CATALOG NO./TYPE
1	Hot-dip galvanized structural steel and pedestals, anchor bolts, mounting bolts, and all necessary bolts and nuts for assembly and erection in the field in accordance with the Drawings for the substation (See separate Bill of Material)	Lot	_____	_____
2	Lightning Masts, 10 ft., complete with clamp for 2/0 copper clad steel and U bolts for mounting	12 Each	_____	_____
3	Static Pole - 85 ft. direct-embedded, with 10-foot lightning mast, vibration dampening, light mount	1 Each	_____	_____
4	Grounding operator platform for air-break	9 Each	_____	_____
16	Power Transformer, 67 kV to 25 x 15 kV wye, three-phase, 30/40/50 MVA with LTC	1 By Commission	N/A	N/A



**BILL OF MATERIAL**

6/6/2022

ITEM NO.	DESCRIPTION	QUANTITY	MANUFACTURER	CATALOG NO./TYPE
20	Feeder Circuit Breaker, Outdoor 27 kV, 1,200 Ampere, three-phase	6 By Commission	<u>N/A</u>	<u>N/A</u>
21	Station Service Transformer, 25 kVA, single-phase, 7,200 Volts to 120 / 240 Volts	By Commission	<u>N/A</u>	<u>N/A</u>
25	Potential Transformer, Outdoor 15 kV, 110 kV BIL, voltage rating 7,200 to 120 Volts (60:1 ratio)	3 Each	<u></u>	<u></u>
81	69 kV Circuit Breaker, 2,000 Amp, 61,000 Ampere momentary, 20,000 Ampere interrupting	By Commission	<u>N/A</u>	<u>N/A</u>
90	Vee-Center Disconnect Switch, 72.5 kV, 350 kV BIL, 1,200 Ampere, 61,000 Ampere momentary, horizontally-mounted, outdoor type, three-pole, group-operated, complete with pipe handle operating mechanism, outboard bearings, guide, arcing horns with four-hole NEMA flat pads to suit location as shown on Drawings	1 Each	<u>USCO</u> Cleveland Price	<u>AGCH 5V-07212</u> CB-AV C26A018G01

**BILL OF MATERIAL**

6/6/2022

ITEM NO.	DESCRIPTION	QUANTITY	MANUFACTURER	CATALOG NO./TYPE
91	Vertical-Break Disconnect Switch, 72.5 kV, 350 kV BIL, 1,200 Ampere, 61,000 Ampere momentary, horizontally-mounted, outdoor type, three-pole, group-operated, complete with pipe handle operating mechanism, outboard bearings, guide, arcing horns with four-hole NEMA flat pads to suit location as shown on Drawings.	2 Each	<u>USCO</u> Cleaveland Price	<u>AVR-07212</u> V2-CA C06A032G22
92	Hookstick Disconnect Switch, 72.5 kV, 350 kV BIL, 1200 Ampere, 61,000 Ampere momentary, horizontally-mounted, outdoor type with four-hole NEMA flat pads. Terminals to suit location with copper live parts. See Drawings.	6 Each	<u>USCO</u> Cleaveland Price	<u>HH6-07212</u> LCO-C C102A150G17
100	Outdoor Hookstick Disconnect Switch, 27 kV, 150 kV BIL, single-pole, 1,200 Ampere continuous, 61,000 Ampere momentary, vertically-mounted, with four-hole NEMA flat pads. Terminals to suit location with copper live parts. See Drawings.	36 Each	<u>USCO</u> Cleaveland Price	<u>HH6-02712</u> LOC-C C102A230G08

**BILL OF MATERIAL**

6/6/2022

ITEM NO.	DESCRIPTION	QUANTITY	MANUFACTURER	CATALOG NO./TYPE
102	Vee-Center-Break Disconnect Switch, 27 kV, 150 kV BIL, 2,000 Ampere, 80,000 Ampere momentary, horizontally-mounted, outdoor type, three-pole, group-operated, complete with pipe handle operating mechanism, outboard bearings, guide, arcing horns with NEMA four-hole flat pads to suit the location shown on the Drawings, with copper live parts.	1 Each	<u>USCO</u> Cleaveland Price	<u>AGCH5V-02720</u> CB-CV C26A039G02
103	Vee-Center-Break Disconnect Switch, 27 kV, 150 kV BIL, 1200 Ampere, 61,000 Ampere momentary, horizontally-mounted, outdoor type, three-pole, group-operated, complete with pipe handle operating mechanism, outboard bearings, guide arcing horns with NEMA four-hole flat pads to suit the location shown on the Drawings, with copper live parts.	6 Each	<u>USCO</u> Cleaveland Price	<u>AGCH5V-02712</u> CB-CV C26A038G02
106	Power Fuse Mounting, 25 kV, 150 kV BIL, 200 Ampere, Type SMD-20	4 Each	<u>S &amp; C</u>	<u>192223R2-G</u>
107	Fuses for Item No. 106, Type SMU-20, 5E, 25 kV, for Station Service Transformer	2 Each	<u>S &amp; C</u>	<u>613005</u>
108	Fuses for Item No. 106, Type SMU-20, 1A, 25 kV, for PTs	6 Each	S & C	703001

**BILL OF MATERIAL**

6/6/2022

ITEM NO.	DESCRIPTION	QUANTITY	MANUFACTURER	CATALOG NO./TYPE
109	Fuses for Item No. 21, 15.5 kV, companion current limiting fuse, 50,000 A.I.C.	2 Each	Cooper	FAH17KV12KBGR1
150	Lightning Arrester, Station Type, 48 kV MCOV, Metal Oxide, for 69 kV	3 By Commission (On Transformer)	N/A	N/A
152	Lightning Arresters, Station Type, 10.2 kV MCOV, Metal Oxide, for 15 kV	3 By Commission (On Transformer)	N/A	N/A
154	Lightning Arresters, Station Class, Type EVP, 48 kV MCOV, metal oxide, for 69 kV	3 Each	OHIO BRASS	EVP004800
155	Lightning Arresters, Station Class, Type EVP, 10.2 kV MCOV for 15 kV, Metal Oxide	18 Each	OHIO BRASS	EVP000900
175	954 AAC, 61-strand aluminum, Magnolia	As Required		
176	477 kmil AAC, 19-strand aluminum, Cosmos	As Required		
178	336.4 kmil ACSR, 18/1 strand, aluminum, Merlin	As Required		

**BILL OF MATERIAL**

6/6/2022

ITEM NO.	DESCRIPTION	QUANTITY	MANUFACTURER	CATALOG NO./TYPE
180	4/0 AWG Bare S.D., 7-strand copper	As Required		
181	2/0 AWG bare S.D., 7-strand copper	As Required		
182	#2 AWG S.D., tinned copper	As Required		
183	2/0 AWG, 40% conductivity, 7-strand, copper clad steel	As Required		
184	#2 AWG S.D., copper-clad	As Required		
190	Aluminum Tubing, 2-inch ID, Alloy 6063-T6, Schedule 40, 40 ft. sections	As Required		
191	Aluminum Tubing, 3-inch ID, Alloy 6063-T6, Schedule 40, 40 ft. sections	As Required		
194	Aluminum Tubing, 4-inch ID, 6063-T6 Schedule 40, 40 ft. sections	As Required		
210	Station Post Insulator, Stacking Type, 69 kV, 350 kV BIL, 3-inch bolt circle, sky gray, Type TR-216	9 Each		

**BILL OF MATERIAL**

6/6/2022

ITEM NO.	DESCRIPTION	QUANTITY	MANUFACTURER	CATALOG NO./TYPE
212	Station Post Insulator, Non-Stacking, 25 kV, 150 kV BIL, 3-inch bolt circle, sky gray, Type TR-208	60 Each		
221	Deadend Assembly, 69 kV, for 477 kcmil, AAC, Polymer Type Insulator, (LAPP 151605-YK, OB 232723-3101) with deadend shoe	By Commission	N/A	N/A
245	Aluminum, Stirrup Clamp, <u>954 kcmil AAC</u> to tinned copper loop	18 Each	Anderson	ACHLS13
246	Bronze, Hot-line Tap Clamp, 4/0 Main to #2 Tap	18 Each	Anderson	BH4FTP
250	Connector, Terminal, aluminum, bolted, <u>954 kcmil AAC</u> to 2-hole pad	18 Each	Travis Pattern & Foundry	PDU# 11-125
250A	Connector, Terminal, aluminum, bolted, <u>954 kcmil AAC</u> to 4-hole pad	36 Each	Travis Pattern & Foundry	PDU# 11-132
250B	Connector, Terminal, aluminum, compression, <u>954 kcmil AAC</u> to 4-hole pad	54 Each	Travis Pattern & Foundry	PDU# 16-161C
251A	Connector, Terminal, aluminum, bolted, 477 kcmil AAC to 4-hole pad	18 Each		

**BILL OF MATERIAL**

6/6/2022

ITEM NO.	DESCRIPTION	QUANTITY	MANUFACTURER	CATALOG NO./TYPE
			Travis Pattern & Foundry	PDU# 11-126
251B	Connector, Terminal, aluminum, compression, 477 kcmil AAC to 4-hole pad	18 Each	Travis Pattern & Foundry	PDU# 16-144C
252	Connector, Tee, aluminum, bolted, <u>954 kcmil AAC</u> cable main to 90° 4-hole pad	3 Each	Travis Pattern & Foundry	PDU# 11-252-90
254A	Connector, Terminal, aluminum Weldment, two cables to 4-hole flat pad for <u>954 kcmil AAC</u>	3 Each	Travis Pattern & Foundry	PDU# 18-762
254B	Connector, Terminal, aluminum bolted, two cables to 4-hole flat pad for <u>954 kcmil AAC</u>	9 Each	Travis Pattern & Foundry	PDU# 11-252
255	Spacer, aluminum cable bolted for dual <u>954 kcmil AAC</u>	9 Each	Travis Pattern & Foundry	PDU# 110-119-CS-4
256	Connector, terminal, copper, compression, #2 tinned copper to a 2-hole pad	12 Each	Travis Pattern & Foundry	PDU# 16-101B
257	Connector, grounding stud, aluminum, bolted, 954 kcmil AAC to grounding stud	36 Each	Travis Pattern & Foundry	

**BILL OF MATERIAL**

6/6/2022

ITEM NO.	DESCRIPTION	QUANTITY	MANUFACTURER	CATALOG NO./TYPE
			Travis Pattern & Foundry	PDU# 17-1302
259	Connector, tee, aluminum, bolted, 477 kcmil ACC cable main to 477 kcmil ACC cable tap	9 Each	Travis Pattern & Foundry	PDU# 12-908
267	Weldment, aluminum tee connector, 3-inch Al tube to 2-hole NEMA pad	4 Each	Travis Pattern & Foundry	PDU# 18-640-WR
269	Weldment, aluminum, coupler for connecting aluminum tubing at 90°, low-side structure – 2-inch bus	6 Each	Travis Pattern & Foundry	PDU# 18-654-90
271	Weldment, aluminum tee connector, 3-inch Al tube to 3-inch Al tube	24 Each	Travis Pattern & Foundry	PDU# 18-175
272	Weldment, Al, tube to tube coupler, 3-inch	3 Each	Travis Pattern & Foundry	PDU# 18-554
273	Weldment, terminal, 3-inch Al tube to 4-hole spade Terminal, 90°	21 Each	Travis Pattern & Foundry	PDU# 18-123-E-90
274	Weldment, terminal, 3-inch Al tube to 4-hole spade	3 Each	Travis Pattern & Foundry	



**BILL OF MATERIAL**

6/6/2022

ITEM NO.	DESCRIPTION	QUANTITY	MANUFACTURER	CATALOG NO./TYPE
277	Weldment, bus support, 3-inch Al tube to 3-inch B.H.C.	21 Each	Travis Pattern & Foundry	PDU# 18-123-E
			Travis Pattern & Foundry	PDU# 19-349
278	Aluminum, corona bell for 3-inch AL tube – Drive Fit	6 Each	Travis Pattern & Foundry	PDU# 111-141
280	Weldment, Tee, 4-inch tube to 2-inch tube, 15°	6 Each	Travis Pattern & Foundry	PDU# 18-281-15
281	Weldment, Tee, 4-inch tube to two (2), 2-inch tubes, 15°	3 Each	Travis Pattern & Foundry	PDU# 18-372-15
282	Aluminum, corona bell for 4-inch Al tube – Drive Fit	9 Each	Travis Pattern & Foundry	PDU# 111-145
283	Weldment, 4-inch Al tube to 4-hole spade Terminal	12 Each	Travis Pattern & Foundry	PDU# 18-130-E
285	Weldment, bus support, 4-inch Al tube to 3-inch B.C.	9 Each	Travis Pattern & Foundry	

**BILL OF MATERIAL**

6/6/2022

ITEM NO.	DESCRIPTION	QUANTITY	MANUFACTURER	CATALOG NO./TYPE
286	Weldment, terminal, 2-inch Al tube to 4-hole spade terminal	36 Each	Travis Pattern & Foundry	PDU# 19-353
286A	Weldment, terminal, 2-inch Al tube to 4-hole spade terminal, 90°	18 Each	Travis Pattern & Foundry	PDU# 18-117E
287	Weldment, aluminum tee connector, 2-inch Al tube to 2-inch Al tube	42 Each	Travis Pattern & Foundry	PDU# 18-117-E-90
288	Weldment, aluminum, tube to tube coupler, 2-inch	3 Each	Travis Pattern & Foundry	PDU# 18-160
289	Weldment, corona bell for 2-inch Al tube	30 Each	Travis Pattern & Foundry	PDU# 18-538
290	Weldment, bus support, 2-inch Al tube to 3-inch BC	36 Each	Travis Pattern & Foundry	PDU# 111-137
291	Weldment, tee, 2-inch Al tube to 4-hole pad	18 Each	Travis Pattern & Foundry	PDU# 19-345
			Travis Pattern & Foundry	PDU# 18-623-WR

**BILL OF MATERIAL**

6/6/2022

ITEM NO.	DESCRIPTION	QUANTITY	MANUFACTURER	CATALOG NO./TYPE
292	Weldment, 2-inch Al tube to grounding stud	18 Each	Travis Pattern & Foundry	PDU# 18-1280-WR
293	Weldment, 3-inch Al tube to grounding stud	3 Each	Travis Pattern & Foundry	PDU# 18-1280-WR
294	Weldment, 4-inch Al tube to grounding stud	6 Each	Travis Pattern & Foundry	PDU# 18-1280-WR
295	Weldment, tee, 4-inch Al tube to 4-inch Al tube	3 Each	Travis Pattern & Foundry	PDU# 18-194
296	Weldment, 90° elbow, 4-inch AL tube to 4-inch AL tube	3 Each	Travis Pattern & Foundry	PDU# 18-658-90
297	Weldment, tee, 4-inch Al tube to 4-hole pad	6 Each	Travis Pattern & Foundry	PDU# 18-641-WR
298	Weldment, variable angle spherical coupler for aluminum pipe connections	3 Each	SEFCOR	WLBUA-5
299	Materials for each 4-hole electrical connection (typical) - all Stainless Steel SS	As Required		

**BILL OF MATERIAL**

6/6/2022

ITEM NO.	DESCRIPTION	QUANTITY	MANUFACTURER	CATALOG NO./TYPE
	a. Bolt HH ½-inch x length required with nut	4 Each		
	b. Flat washer	8 Each		
	c. Spring washer	4 Each		
495	Transition Plate, aluminum to copper, 2-hole	As Required	Travis Pattern & Foundry	PDU# TP2
496	Transition Plate, aluminum to copper, 4-hole	As Required	Travis Pattern & Foundry	PDU# TP3
619	Connector, bronze, terminal, bolted, 2/0-4/0 AWG copper to 2-hole pad	15 Each	Travis Pattern & Foundry	PDU# 11-101
620	Connector, bronze, 4-hole pad for 2/0 Cu ground conductor for grounding of Control House	4 Each	Travis Pattern & Foundry	PDU# 11-105
621	Connector, bronze, terminal, bolted, dual 4/0 copper to 2-hole pad	2 Each	Travis Pattern & Foundry	PDU# 11-230

**BILL OF MATERIAL**

6/6/2022

ITEM NO.	DESCRIPTION	QUANTITY	MANUFACTURER	CATALOG NO./TYPE
815	Connector for supporting dual conductor ground wire on and connecting to steel columns and beams, #4 thru 300 kcmil	350 Each	Travis Pattern & Foundry	PDU# 17-164-SB
840	Connector, bronze terminal tap lug for attachment of ground grid to operator platforms, #6-250 kcmil copper conductor	21 Each	Anderson	TLS-42
845A	Inhibitor compound, non-gritted, anti-oxygen, conductive, 16 oz-tubes	7 Each	Anderson	VS
845B	Inhibitor compound, gritted, anti-oxygen, conductive, 16 oz-tubes	7 Each	Anderson	VSG
850	Fiberglass hookstick, 16'-0" (Hastings 541-16, or approved equal)	1 Each		
860	4" x 4" x 20' mounted container (for hooksticks)	1 Each		
881	Animal Guards, bus support, feeder dip poles, switches	146 Each	TE Raychem	BISG-G-60/115-02
882	Animal Guards, breaker bushings	42 Each	TE Raychem	BCAC-G-IC-8D/18 (B6)

**BILL OF MATERIAL**

6/6/2022

<u>ITEM NO.</u>	<u>DESCRIPTION</u>	<u>QUANTITY</u>	<u>MANUFACTURER</u>	<u>CATALOG NO./TYPE</u>
883	Animal Guards, Vertical bus support, switches	72 Each	<u>TE Raychem</u>	<u>BISG-G-100/400</u>
884	Animal Guards, Transformer Bushings	6 Each	<u>TE Raychem</u>	<u>BCAC-G-IC-10.5D/20</u>
885	Animal Guards, Conductor Cover	100 FT	<u>TE Raychem</u>	<u>MVCC-G-10/.40 (B100)</u>
886	Animal Guards, Conductor Cover	400 FT	<u>TE Raychem</u>	<u>MVCC-G-25/1.0 (B25)</u>
886	Animal Guards, Fusion Tape	4 Std. Packs	<u>TE Raychem</u>	<u>MVFT-G-2-12 (B4)</u>

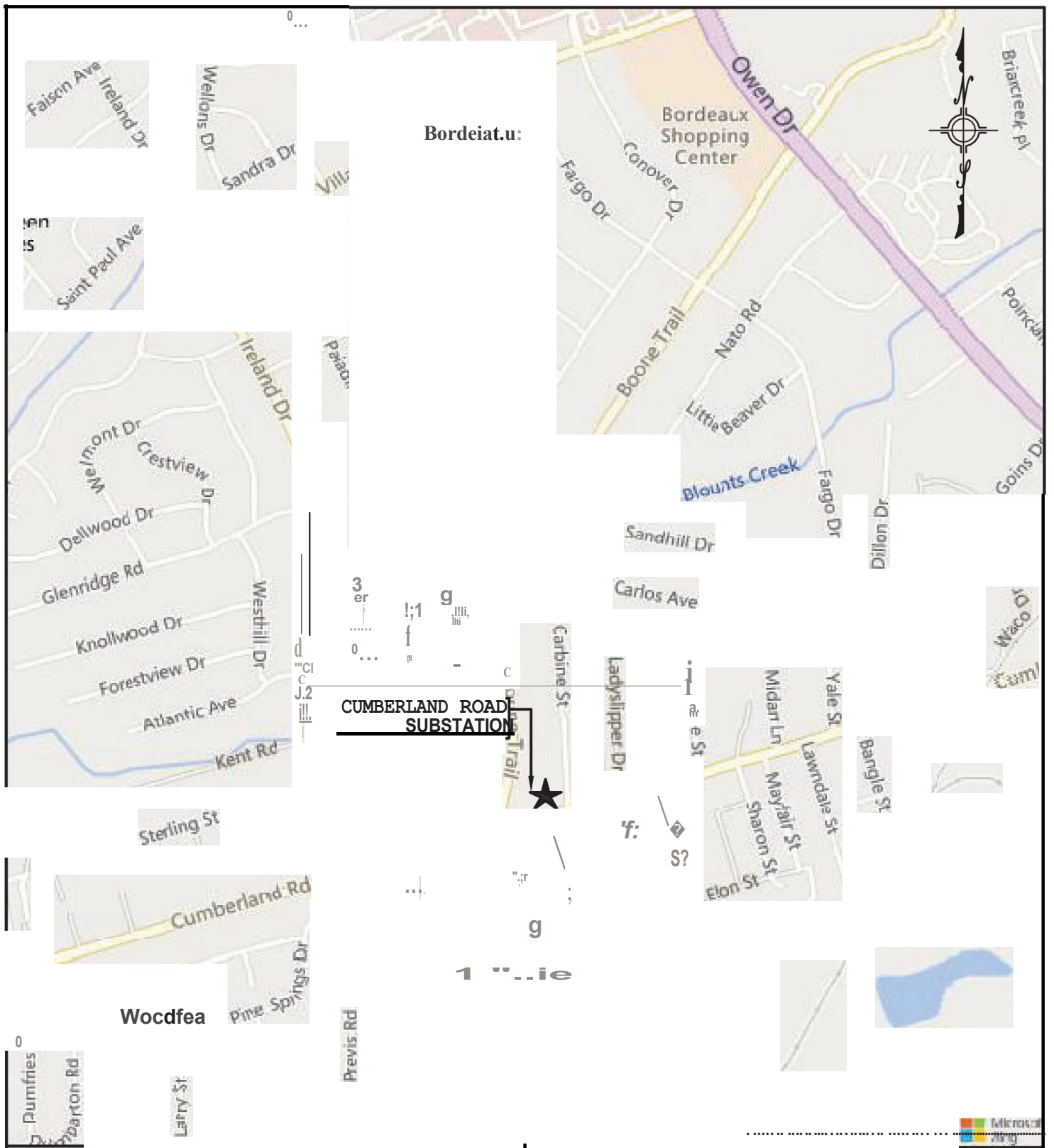

**SITE LOCATION**

ADDRESS:  
2336 CARBINE STREET,  
FAYETTEVILLE, NC 28306

PWC OF THE CITY OF FAYETTEVILLE  
FAYETTEVILLE, NORTH CAROLINA

**CUMBERLAND ROAD 69 TO 15 KV SUBSTATION  
VICINITY MAP**



DWN. AAI	DATE: 06/06/22	DWG. NO.	
CKD. EAR	APPD. EAR		
SCALE: 1" = 1,000'	FILE: 12510VM		
JOB NO. 2210713	DATE	REVISION	VM-1
© 06/2022			

**ATTACHMENT B: BID PRICING FORM**

---

**Bidder Information:**

**Name of Company**

**Address**

**Phone Number**

**Email Address**

**Federal ID No.**

**Is the business SDBE,  
MWBE, DBE, or HUB  
Printed Name**

**Title**

**Signature**

**Date**

**Furnish And Deliver:**

Line Item	QTY.	UOM	DESCRIPTION	LEAD TIME	UNIT PRICE	EXTENDED PRICE
1	1	LS	CUMBERLAND RD. SUBSTATION STRUCTURE AND EQUIPMENT AS DESCRIBED IN TECHNICAL SPECIFICATIONS AND DRAWINGS			
TOTAL EXTENDED PRICE: \$ _____						



**ATTACHMENT C: CERTIFIATION OF PRIMARY PARTICIPANT REGARDING DEBARMENT, SUSPENSION AND OTHER RESPONSIBILITY MATTERS**

---

The Primary Participant, \_\_\_\_\_ (major third party contractor), certifies to the best of its knowledge and belief, that it and its principals:

1. Are not presently debarred, suspended, proposed for debarment, declared ineligible, or voluntarily excluded from covered transactions by any Federal department or agency;
2. Have not within a three-year period preceding this proposal been convicted of or had a civil judgment rendered against them for commission of fraud or a criminal offense in connection with obtaining, attempting to obtain, or performing a public (Federal, State or local) transaction or contract under a public transaction; violation of Federal or State antitrust statutes or commission of embezzlement, theft, forgery, bribery, falsification or destruction of records, making false statements, or receiving stolen property;
3. Are not presently indicted for or otherwise criminally or civilly charged by a governmental entity (Federal, State or local) with commission of any of the offenses enumerated in paragraph (2) of this certification; and
4. Have not within a three-year period preceding this application/proposal had one or more public transactions (Federal, State or local) terminated for cause or default.

(If the primary participant is unable to certify to any of the statements in this certification, the participant shall attach an explanation to this certification.)

THE PRIMARY PARTICIPANT \_\_\_\_\_ CERTIFIES OR AFFIRMS THE TRUTHFULNESS AND ACCURACY OF THE CONTENTS OF THE STATEMENTS SUBMITTED ON OR WITH THIS CERTIFICATION AND UNDERSTANDS THAT THE PROVISIONS OF 31 U.S.C. SECTIONS 3801 ET. SEQ. ARE APPLICABLE THERETO.

\_\_\_\_\_  
Signature

\_\_\_\_\_  
Title

\_\_\_\_\_  
Printed Name

\_\_\_\_\_  
Date

# PWC At a Glance



## Customers



- In operation since 1905 (116 years)
- Provide Electric, Water and Wastewater Services
- Total Customers: 119,380
- Number of Services: 273,794
  - Electric: 82,304
  - Water: 90,430
  - Wastewater: 89,913
- Customers with 2+ services: 75%
- Annual Customer Turnover: 20-25%

## Customer Service



- Annual Customer Contacts: 433,794
- Average Monthly Calls: 31,452
- Annual Bills Generated: 1.4 Million
- Customer Incentive Programs: 13
- Annual Water Leak Notifications: 21,850

## Employees



- Number of Employees: 651
- Average Tenure of Employees: 10.37 years
- Average Age: 44.59
- Annual Turnover: 6.0%\*
- Annual Hours Worked: 1.2 Million

\*non retirement

## Facilities



- Butler-Warner Generation Plant (268 MW)
- PO Hoffer Water Treatment Facility (39.5 MGD)
- Glenville Lake Water Treatment Facility (18.0 MGD)
- Cross Creek Water Reclamation Facility (25 MGD)
- Electric Service Area: 147 Sq. Miles
- Water Service Area: 163 Sq. Miles
- Wastewater Service Area: 142 Sq. Miles

## Electric Operations



- Purchase Wholesale Power from Duke Energy
- Only NC municipal system to own/operate a generation plant (Dispatched for use by Duke Energy)
- Generation Capacity: 268 MW
- Annual MWH Sold: 1.9 Million
- System Peak: 499 MW (Feb. 9, 2015)
- Reliability Rate: 99.9906%
- Electric Distribution Substations: 32
- Distribution Lines: 1,351 miles
- Transmission Lines: 142 miles
- Streetlights/Area Lights: 37,441

## Water/Wastewater Operations



- Population Served: 225,000
- Drinking Water Treated: 11.2 Billion Gallons/Year
- 100% Complaint for all EPA Drinking Water Standards
- Daily Water Treatment Capacity: 57.5 Million Gallons
- Daily Wastewater Treatment Capacity: 46 Million Gallons
- Water/Wastewater Infrastructure: 2,700 miles
- Hydrants: 8,300
- Sanitary Sewer Lift Stations: 82

## Financial



- Annual Operating Budget: \$405.2 Million
- Total Assets: \$1.44 Billion
- Bond Rating: Aa2 (Moody's), AA (Standard and Poor), AA (Fitch)
- Annual Local Purchases: \$25 Million
- Operations & Maintenance Expenses per Customer: \$432 (\$556 National Median)
- Annual Contributions to City of Fayetteville in Lieu of Taxes: \$11.4 Million
- Annual Streetlight Services: \$3.9 Million
- Annual Economic Development: \$1.2 Million (thru 2021)

## SALE OF GOODS AGREEMENT

This Sale of Goods Agreement (“Agreement”) is made by and between the City of Fayetteville (the “City”), by and through the Fayetteville Public Works Commission (“PWC”), a North Carolina public authority, and \_\_\_\_\_ [insert seller’s full legal name] (“Seller”), a \_\_\_\_\_ [identify the legal entity and State in which formation was accomplished] (each of PWC and Seller is a “Party” and both are collectively the “Parties”) as of the date of execution last written below (the “Effective Date”). In consideration of the mutual covenants and agreements contained herein, and other good and valuable consideration, the receipt and sufficiency of which is hereby acknowledged, The Parties agree as follows:

1. Sale of Goods. Seller shall sell to PWC and PWC shall purchase from Seller the following [Identify the goods specifically] (the “Goods”). PWC may issue a purchase order for the Goods that specifies any additional applicable terms and conditions set forth for the purchase (a “Purchase Order”), but such Purchase Order is subject to the terms of this Agreement. In the event of a conflict between the provisions of this Agreement and the provisions of any Contract Documents, attachment, exhibit or Purchase Order made pursuant to this Agreement, the terms of this Agreement shall govern.

2. Contract Documents. “Contract Documents” means, collectively, the following documents that were either made available to Seller by PWC during the bid solicitation process (including Drawings) or executed by the Parties, or both, which are all incorporated by reference herein:

- a. This Agreement
- b. Notice to Prospective Bidders
- c. Definitions
- d. Instructions to Bidders
- e. General Conditions
- f. Materialman’s Proposal
- g. Bid Bond
- h. Technical Specifications
- i. Purchase Order(s)
- j. Addenda

3. Delivery of Goods. Seller shall deliver the Goods [EITHER: “on or before \_\_\_\_\_” OR “as specified in the Contract Documents or an applicable Purchase Order issued by PWC” OR “as otherwise agreed in writing by the Parties”] (the “Delivery Date”). Timely delivery of the Goods is of the essence. If Seller fails to deliver the Goods on or before the Delivery Date, PWC may, without any liability to Seller, terminate this Agreement immediately by providing written notice to Seller. Unless otherwise specified in an applicable Purchase Order or the Contract Documents, excluding this Agreement, all Goods shall be delivered to PWC’s Warehouse at 955 Old Wilmington Road, Fayetteville, North Carolina 28301 (the “Delivery Point”) during PWC’s normal business hours. Delivery shall be made FOB Delivery Point.

4. Title and Risk of Loss. Title of the Goods passes to PWC upon delivery of the Goods to the Delivery Point. Seller bears all risk of loss or damage to the Goods until delivery of the Goods to the Delivery Point.

5. Packaging. Seller shall properly pack, mark, and ship the Goods as instructed by PWC and otherwise in accordance with applicable law and industry standards and shall provide PWC with all shipment documentation showing the quantity of pieces in shipment, the number of cartons or containers in shipment, Seller's name, the airway bill or bill of lading number, and the state of origin.

6. Inspection and Rejection of Nonconforming Goods. PWC has the right to inspect the Goods on or after the Delivery Date. PWC, at its sole option, may inspect all or a sample of the Goods, and may reject all or any portion of the Goods if it determines the Goods are nonconforming or defective. If PWC rejects any portion of the Goods, PWC has the right, effective upon written notice to Seller, to: (a) terminate this Agreement in its entirety and require Seller to remove the Goods in a commercially reasonable time period or pay the full cost and expense to have the rejected Goods returned to Seller; or (b) reject the Goods and require replacement of the rejected Goods at Seller's sole expense. If PWC requires replacement of the Goods, Seller shall, at its sole expense and in the lesser of ninety (90) days or the number of days between any applicable Purchase Order of PWC and the Delivery Date, replace the nonconforming Goods and pay for all related expenses, including, but not limited to, transportation charges for the return of the defective goods and the delivery of replacement Goods. Any inspection or other action by PWC under this Section shall not reduce or otherwise affect Seller's obligations under this Agreement, including Seller's warranties, and PWC shall have the right to conduct further inspections after Seller has carried out its remedial actions.

7. Price. PWC shall purchase the Goods from Seller in the total amount of \$\_\_\_\_\_ ("Price"). The Price includes all packaging, transportation costs to the Delivery Location, insurance, fees, and applicable taxes, including, but not limited to, all sales, use, or excise taxes. No increase in the Price is effective, whether due to increased material, labor, transportation costs or otherwise, without the prior written consent of PWC.

8. Billing and Payment. Seller shall invoice PWC within thirty (30) days after the completion of the delivery of the Goods. PWC shall pay the undisputed portion of the invoice within forty-five (45) calendar days after PWC's receipt of the invoice. All payments from PWC to Seller shall be transferred electronically to Seller's designated financial institution, and Seller shall, prior to delivery of its invoice to PWC, supply the name of Seller's financial institution, routing number, and account number on the form available from PWC and provide to PWC a completed and signed IRS Form W-9. Seller has the right to impose a late payment charge of one percent (1%) per month for amounts unpaid by PWC by the date due.

Provider shall comply with all of the following requirements so that PWC may recover the full amount of sales and use tax under North Carolina law permitted under the law:

- a. Furnish PWC documentary evidence showing the material used, sales tax paid, and County paid (County of sale). The documentary evidence shall include Provider's certified statement showing total purchases of materials from each separate vendor and total sales taxes charged to PWC and paid by Provider. The documentary evidence shall also include Provider's certified statement as to the amount paid by PWC for sales tax on the Goods. A certified form is required even if no sales tax was paid for the pay request period. Materials used from Provider's warehouse stock shall be shown in a

- certified statement at warehouse stock prices and amount of County of Use Tax charged to PWC and paid by Provider;
- b. Provider shall furnish to PWC invoices or copies of invoices for all materials purchased for said work within pay request period, and such invoices shall state the amount of North Carolina Sales Tax, if any, paid for the Goods. Provider shall also furnish to PWC invoices identifying the amount paid for the sales and use tax on Services that are subject to such taxation under North Carolina law; and
  - c. Provider shall not include any tax paid on supplies, tools, and equipment that Provider uses to perform its obligations under this Agreement.

9. Warranties. Seller warrants to PWC that for a period of twenty-four (24) months from the Delivery Date, all Goods will: (a) be free from any defects in workmanship, material and design; (b) conform to applicable specifications, drawings, designs, samples and other requirements set forth in the Contract Documents or as specified by PWC and agreed to by Seller; (c) be fit for their intended purpose and operate as intended; (d) be free and clear of all liens, security interests, or other encumbrances; and (e) not infringe or misappropriate any third party's patent or other intellectual property rights. These warranties survive any delivery, inspection, acceptance or payment of or for the Goods by PWC. These warranties are cumulative and in addition to any other warranty provided by law or equity. Any applicable statute of limitations runs from the date of PWC's discovery of the noncompliance of the Goods with the foregoing warranties. If PWC gives Seller notice of noncompliance with this Section 9, Seller shall, at its own cost and expense, within thirty (30) days replace or repair the defective or nonconforming Goods and pay for all related expenses, including, but not limited to, transportation charges for the return of the defective or nonconforming goods to Seller and the delivery of repaired or replacement Goods to PWC.

10. Termination. Notwithstanding any other or additional remedies that may be provided under this Agreement, PWC may terminate this Agreement with immediate effect upon written notice to the Seller, either before or after the acceptance of the Goods, if: (a) Seller repudiates, or threatens to repudiate, any of its obligations under this Agreement; (b) Seller is in breach of, or threatens to breach, any representation, warranty, or covenant of Seller under this Agreement and either the breach cannot be cured or, if the breach can be cured, it is not cured by Seller within a commercially reasonable period of time under the circumstances, in no case exceeding seven (7) days following Seller's receipt of Notice of such breach; (c) Seller fails to, or threatens to fail to, timely deliver Goods conforming to the requirements of, and otherwise in accordance with, the terms and conditions of this Agreement; or (d) Seller becomes insolvent, files a petition for bankruptcy, or commences or has commenced against it proceedings relating to bankruptcy, receivership, reorganization, or assignment for the benefit of creditors. PWC shall be obligated to pay Seller only for work performed and reasonable expenses incurred until delivery of the notice of termination.

11. Insurance. During the term of this Agreement and for a period of three (3) years after the date of this Agreement, Seller shall, at its own expense, maintain and carry insurance in full force and effect that includes, but is not limited to, commercial general liability (including product liability) with limits no less than \$1,000,000 for each occurrence and \$3,000,000 in the aggregate and umbrella liability in a sum no less than \$5,000,000, which insurance shall be placed with insurance companies authorized to do business in the State of North Carolina and rated A minus VII or better by the current edition of Best's Key Rating Guide or otherwise approved in writing by PWC. Prior to delivering any Goods, Seller shall deliver to PWC

certificates of insurance confirming each such coverage, and Seller shall direct its insurers to provide annually to PWC certificates confirming each such coverage during the coverage period. PWC shall be named as an additional insured in the insurance policy. Seller shall not reduce or allow the required insurance coverages to lapse without PWC's prior written approval. All policies for insurance must be endorsed to contain a provision giving PWC a thirty (30) calendar day prior written notice by certified mail of any cancellation of that policy or material reduction in coverage. Should a notice of cancellation be issued for non-payment of premiums or any part thereof, or should Seller fail to provide and maintain certificates as set forth herein, PWC shall have the right, but not the obligation, to pay such premium to the insurance company or to obtain such coverage and to deduct such payment from any sums that may be due or become due to Seller, or to seek reimbursement for said payments from Seller. Any such sums paid by PWC shall be due and payable immediately by Seller upon notice from PWC. The insurance provisions of this Agreement shall not be construed as a limitation on Seller's responsibilities and liabilities pursuant to the terms and conditions of this Agreement.

12. Indemnification. Seller shall indemnify, defend, and hold harmless PWC and its Commissioners, officers, employees, agents, and representatives (collectively, "Indemnitees") from and against all claims, actions, liabilities, damages, losses, costs, and expenses (including, without limitation, injury to or death of any persons and damage to property, economic and consequential damages and attorneys' fees) asserted by one or more third parties against one or more of the Indemnitees arising out of negligent or willful acts, violations of law, infringement of any patent, trademark, trade secret, copyright, or other intellectual property right of a third party, or omissions or breach of the obligations set forth in this Agreement by Seller or any of its employees, agents, representatives, and subcontractors. Seller's obligation to indemnify, defend, and hold harmless the Indemnitees shall survive the termination of this Agreement and shall include the duty to pay for the reasonable attorney's fees and costs associated with defending the Indemnitee(s) by the legal counsel of each Indemnitee's choice.

13. Notices. Any notice which either Party is required or desires to give the other shall be deemed sufficiently given if, in writing, it is delivered personally, or sent by certified U.S. mail, return-receipt requested, postage prepaid, to the addresses listed hereinbelow, or such other address as either Party shall give to the other Party by written notice in accordance herewith. Any notice given herein by personal delivery shall be deemed delivered when received. Any properly addressed notice given herein by certified mail shall be deemed delivered on the third Business Day after the same is deposited in an official United States Post Office, postage prepaid, or if sooner upon the date when the return receipt therefor is signed, or refusal to accept the mailing by the addressee is noted thereon by the postal authorities.

To PWC:  
Fayetteville Public Works Commission  
Attn: Timothy Bryant, CEO/General Manager  
PO Box 1089  
Fayetteville, NC 28302

To Seller:  
[INSERT MAILING ADDRESS]

14. Compliance. Seller hereby acknowledges that "E-Verify" is the federal E-Verify program operated by the US Department of Homeland Security and other federal agencies which is used to verify the work authorization of newly hired employees pursuant to federal law

and in accordance with Article 2, Chapter 64 of the North Carolina General Statutes. Seller further acknowledges that all employers, as defined by Article 2, Chapter 64 of the North Carolina General Statutes, must use E-Verify and after hiring an employee to work in the United States, shall verify the work authorization of the employee through E-Verify in accordance with NCGS §64-26(a). Seller hereby pledges, attests, and warrants through execution of this Agreement that Seller complies with the requirements of Article 2, Chapter 64 of the North Carolina General Statutes and further pledges, attests, and warrants that all subcontractors currently employed by or subsequently hired by Seller to provide services for PWC shall comply with all E-Verify requirements. Failure to comply with the above requirements shall be considered a breach of this Agreement. Seller hereby further acknowledges that the execution and delivery of this Agreement constitutes Seller's certification to PWC and to the North Carolina State Treasurer that, as of the Effective Date, Seller is not listed on (a) the Final Divestment List created and maintained by the North Carolina Department of State Treasurer pursuant to the Iran Divestment Act of 2015, Chapter 147, Article 6E of the General Statutes of North Carolina (the "Iran Divestment Act"); or (b) the list of companies that the North Carolina State Treasurer determines to be engaged in a boycott of Israel in accordance with Article 6G of Chapter 147 of the General Statutes of North Carolina. Seller represents and warrants to Commission that Seller, and all persons and entities owning (directly or indirectly) an ownership interest in it: (i) are not, and will not become, a person or entity with whom a party is restricted from doing business with under regulations of the Office of Foreign Asset Control ("OFAC") of the Department of the Treasury (including, but not limited to, those named on OFAC's Specially Designated and Blocked Persons list) or under any statute, executive order (including, but not limited to, the September 24, 2001, Executive Order 13224 Blocking Property and Prohibiting Transactions with Persons Who Commit, Threaten to Commit, or Support Terrorism), or other governmental action; and (ii) are not knowingly engaged in, and will not knowingly engage in, any dealings or transactions or be otherwise associated with such persons or entities described in clause (i) above. Seller also shall at all times during the term of this Agreement comply with Executive Order 11246, including but not limited to the Equal Opportunity Clause requirements set forth in 41 C.F.R. § 60-1.4. Seller shall abide by the requirements of 41 CFR 60-300.5(a) and 60-741.5(a) prohibiting discrimination against qualified individuals on the basis of protected veteran status or disability and requiring affirmative action by covered prime contractors and subcontractors to employ and advance in employment qualified protected veterans and individuals with disabilities.

15. Cumulative Remedies. All rights and remedies provided in this Agreement are cumulative and not exclusive, and the exercise by either Party of any right or remedy does not preclude the exercise of any other rights or remedies that may now or subsequently be available at law or in equity.

16. Miscellaneous Provisions. Seller is and shall remain an independent contractor. Nothing contained in this Agreement shall be deemed or construed to create the relationship of principal and agent or of partnership or of joint venture or of any association whatsoever between the Parties. No breach or non-performance of any term of this Agreement shall be deemed to be waived by either Party unless said breach or non-performance is waived in writing and signed by the Parties. No waiver of any breach or non-performance under this Agreement shall be deemed to constitute a waiver of any subsequent breach or non-performance, and for any such breach or non-performance each Party shall be entitled to such remedies as provided by law. No consent or waiver by a Party shall be effective unless it is in writing and then only to the extent specifically stated. The invalidity, illegality, or un-enforceability of any portion or provision of this Agreement shall in no way affect the validity, legality, and/or enforceability of

any other portion or provision of this Agreement. Any invalid, illegal, or unenforceable provision of this Agreement shall be deemed severed from this Agreement, and the balance of the Agreement shall be construed and enforced the same as if the Agreement had not contained any portion or provision which was invalid, illegal, or unenforceable; provided, however, severability shall not prevent this entire Agreement from being void in the event any portion or provision of this Agreement that is of the essence of this Agreement shall be void. This is the entire agreement of the Parties on the subject matter hereof, and all prior negotiations, representations, proposals, letters, agreements, understandings, or other communications between the Parties, whether written or oral, are hereby merged into the Agreement and superseded by this Agreement. This Agreement shall not be modified unless such modifications are evidenced in writing, signed by both Parties. Nothing herein shall be construed to give any right or benefits hereunder to anyone other than the Parties. This Agreement shall be governed by the laws of the State of North Carolina without the application of the laws of any other state. The exclusive venue for all mediations and litigation and any other legal proceedings regarding this Agreement shall be the State and Federal Courts serving Cumberland County, North Carolina, and Seller consents to personal jurisdiction in such courts. Seller irrevocably waives, to the fullest extent permitted by law, any objection that it may now or hereafter have to the laying of the venue of any such suit, action or proceeding in any such court serving Cumberland County or that any such suit, action or proceeding brought in any such court serving Cumberland County has been brought in an inconvenient forum. This Agreement may be executed in counterparts with the same effect as if the signatures to each counterpart were upon a single instrument, and all such counterparts together shall be deemed an original of this Agreement. For purposes of this Agreement, a facsimile copy or scanned copy or photocopy of a party's signature shall be sufficient to bind such party. This Agreement shall be subject to execution by electronic means in accordance with Article 40 of Chapter 66 of the North Carolina General Statutes. The titles of the paragraphs throughout this Agreement are for convenience only and the words contained therein shall in no way be held to explain, modify, amplify, or aid in the interpretation, construction, or meaning of the provisions of this instrument.

17. Conflicts. Except with PWC's knowledge and prior written consent, the Seller shall not engage in any activity or accept any employment, interest or contribution that would reasonably appear to compromise the Seller's professional judgment with respect to the Goods. The Seller shall disclose to PWC any business or personal relationship with any Commissioner, officer, director, manager, or supervisor of PWC.

IN WITNESS WHEREOF, the Parties have executed this Agreement by their duly authorized representatives as of the Effective Date.

Fayetteville Public Works Commission

[INSERT SELLER'S FULL LEGAL NAME]

By: \_\_\_\_\_  
Timothy Bryant, CEO/General Manager

By: \_\_\_\_\_  
(Printed Name) (Title)

Date: \_\_\_\_\_

Date: \_\_\_\_\_



This instrument has been preaudited in the manner required by the Local Government Budget and Fiscal Control Act (N.C. Gen. Stat. § 159-1 et seq.).

By: \_\_\_\_\_  
Rhonda Haskins, Chief Financial Officer

Approved as to form:

\_\_\_\_\_  
Legal Dept.

SAMPLE

**FAYETTEVILLE PUBLIC WORKS COMMISSION'S  
MWDBE COMPLIANCE PROVISIONS**

**APPLICATION:**

The requirements of Fayetteville Public Works Commission (PWC) Minority, Women, and Disadvantaged Business Enterprise (MWDBE) Program for participation specific contracts are hereby made part of the Contract Documents. Copies of the Program may be obtained from:

Fayetteville Public Works Commission  
Economic Inclusion Programs  
P.O. Box 1089  
Fayetteville, North Carolina 28302  
Phone (910) 223-4016 Fax (910) 483-1429  
E-mail: [EIProgram@faypwc.com](mailto:EIProgram@faypwc.com)

NCDOT DBE Directory: [www.ebs.nc.gov/VendorDirectory](http://www.ebs.nc.gov/VendorDirectory)

HUB Directory: <https://ncadmin.nc.gov/businesses/hub>

**MWDBE Compliance Requirements:**

1. The Bidder shall provide, with their Bid Form, at the time bids are due, the documents set forth below, properly executed. Returning executed copies indicates and establishes that the Bidder understands and agrees to any incorporated MWDBE contract provisions.
2. All Bidders must provide with their Bid Form, at the time bids are due, a properly completed and executed copy of **either:**
  - Affidavit A – Listing of Good-Faith Efforts **OR**
  - \*Affidavit B – Intent to Self-Perform with Own Workforce.

\*Affidavit B should **only** be used if the Contractor will perform **ALL Elements** of the Work on this project with their own forces **AND** will complete **ALL Elements** of this project **WITHOUT** the use of subcontractors, material suppliers, or providers of professional services.
3. Upon being identified as the apparent lowest responsive, responsible Bidder, a Bidder shall, within twenty-four (24) hours of PWC's notification provide a properly completed and executed copy of **either:**
  - Affidavit C – Percentage of MWDBE Participation **OR**
  - Affidavit D – Good-Faith Efforts.
4. All Bidders must provide with their Bid Form, at the time bids are due, a properly completed and executed copy of Affidavit E- Identification of MWDBE/Local Participation Form

All written statements, certifications, or intentions made by the Bidder shall become a part of the agreement between the Contractor and Fayetteville Public Works Commission for performance of this contract.

### **SUBCONTRACTOR PAYMENT REQUIREMENTS:**

North Carolina General Statutes 143-134.1 (N.C.G.S.) states that the percentage of retainage on payments made by the prime contractor to the subcontractor shall not exceed the percentage of retainage on payments made by the Fayetteville Public Works Commission to the prime contractor. Failure to comply with this provision shall be considered a breach of the contract, and the contract may be terminated in accordance with the termination provisions of the contract.

The Contractor shall provide an itemized statement of payments to each MWDBE subcontractor before final payment is processed.

The Contractor shall provide an itemized statement of payments to each NON-MWDBE subcontractor before final payment is processed.

---

Contractor

---

Signature

---

Printed Name

---

Title

---

Date

### Affidavit A: Listing of the Good Faith Efforts

Affidavit of \_\_\_\_\_  
(Name of Bidder)

**I have made a good faith effort to comply under the following areas checked:**

<b>Total Available GFE Points: 155</b>		<b>Minimum Number GFE Points Required: 50</b>
<b>Points</b>		
10	Contacting minority businesses that reasonably could have been expected to submit a quote and that were known to the contractor or available on State or local government-maintained lists at least 10 days before the bid or proposal date and notifying them of the nature and scope of the work to be performed.	
10	Making the construction plans, specifications and requirements available for review by prospective minority businesses or providing these documents to them at least 10 days before the bid or proposals are due.	
15	Breaking down or combining elements of work into economically feasible units to facilitate minority participation.	
10	Working with minority trade, community, or contractor organizations identified by the Office for Historically Underutilized Businesses and included in the bid documents that provide assistance in recruitment of minority businesses.	
10	Attending any pre-bid meetings scheduled by the public owner.	
20	Providing assistance in getting required bonding or insurance or providing alternatives to bonding or insurance for subcontractors.	
15	Negotiating in good faith with interested minority businesses and not rejecting them as unqualified without sound reasons based on their capabilities. Any rejection of a minority business based on lack of qualification should have the reasons documented in writing.	
25	Providing assistance to an otherwise qualified minority business in need of equipment, loan capital, lines of credit, or joint pay agreements to secure loans, supplies, or letters of credit, including waiving credit that is ordinarily required. Assisting minority businesses in obtaining the same unit pricing with the bidder's suppliers in order to help minority businesses in establishing credit.	
20	Negotiating joint venture and partnership arrangements with minority businesses in order to increase opportunities for minority business participation on a public construction or repair project when possible.	
20	Providing quick pay agreements and policies to enable minority contractors and suppliers to meet cash-flow demands.	
<b>Total GFE Points (Claimed by Bidder):</b>		<b>Total GFE Points (Assessed by PWC):</b>

In accordance with NCGS 143-128.2(d) the undersigned will enter into a formal agreement with the firms listed in the Identification of Small Disadvantaged Business Participation schedule conditional upon execution of a contract with the Owner. Failure to abide by any applicable statutory provision may constitute a breach of the contract. The undersigned hereby certifies that he or she has read the terms of the MWDBE business commitment and is authorized to bind the Bidder to the commitment herein set forth.

Date: \_\_\_\_\_ Name of Authorized Officer: \_\_\_\_\_



State of North Carolina, County of \_\_\_\_\_

Subscribed and sworn to before me this \_\_\_\_\_ day of  
\_\_\_\_\_ 20\_\_\_\_ Notary Public

My commission expires \_\_\_\_\_

**Affidavit B: Intent to Perform Contract with Own Workforce**

Affidavit of \_\_\_\_\_  
(Name of Bidder)

**I hereby certify that it is our intent to perform 100% of the work required for contract:**

\_\_\_\_\_  
(Name of Project)

In making this certification, the Bidder states that the Bidder does not customarily subcontract elements of this type project, and normally performs and has the capability to perform and will perform **all elements of the work** on this project with his/her own current workforces; and will complete all elements of this project **without** the use of subcontractors, material suppliers, or providers of professional services.

The Bidder agrees to provide any additional information or documentation requested by the Owner in support of the above statement.

The undersigned hereby certifies that he or she has read this certification and is authorized to bind the Bidder to the commitments herein contained.

Date: \_\_\_\_\_ Name of Authorized Officer: \_\_\_\_\_

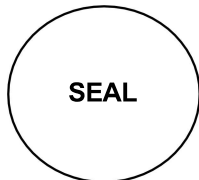

State of North Carolina, County of \_\_\_\_\_

Subscribed and sworn to before me this \_\_\_\_\_ day of 20\_\_

Notary Public \_\_\_\_\_

My commission expires \_\_\_\_\_

### Affidavit C: Percentage of MWDBE Participation

Affidavit of \_\_\_\_\_  
(Name of Bidder)

I hereby certify that on contract: \_\_\_\_\_  
(Name of Project)

\$ \_\_\_\_\_  
(Dollar Amount of Total Bid)

I will expend a minimum of \_\_\_\_\_% of the total dollar amount of the contract with Minority, Women, and Disadvantaged Business Enterprises (MWDBE). MWDBEs will be employed as subcontractors, vendors, or providers of professional services. Such work will be subcontracted to the following firms listed below.

<u>Name, Address, &amp; Phone No.</u>	<u>*MWDBE Category</u>	<u>NAICS</u>	<u>Dollar Value</u>	<u>% of Contract</u>

\*MWDBE categories: Black-African Americans (B), Hispanic-Americans (H), Asian- Americans (A), Native-Americans (I), Women (F), Socially/Economically Disadvantaged (D)

Pursuant to NCGS 143-128.2(d), the undersigned will enter into a formal agreement with MWDBEs for work listed in this schedule conditional upon execution of a contract with the Owner. Failure to fulfill this commitment may constitute a breach of the contract.

The undersigned hereby certifies that he or she has read the terms of this commitment and is authorized to bind the Bidder to the commitment herein set forth.

Date: \_\_\_\_\_ Name of Authorized Officer: \_\_\_\_\_

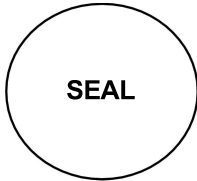

State of North Carolina, County of \_\_\_\_\_

Subscribed and sworn to before me this \_\_\_\_\_ day \_\_\_\_\_ 20\_\_\_\_

Notary Public \_\_\_\_\_

My commission expires \_\_\_\_\_

**Affidavit D: Good Faith Efforts**

If Owner determines using reasonable discretion that Affidavit C is insufficient, Bidder agrees to provide the following information regarding any good-faith efforts.

<u>Name, Address, &amp; Phone No.</u>	<u>*MWDBE Category</u>	<u>NAICS</u>	<u>Dollar Value</u>

\*MWDBE categories: Black-African Americans (B), Hispanic-Americans (H), Asian- Americans (A), Native-Americans (I), Women (F), Socially/Economically Disadvantaged (D)

Bidder may be requested to provide documentation of the Bidder’s good-faith efforts. Examples of documentation may include the following:

- a. Copies of solicitations for quotes to MWDBEs. Each solicitation may include a specific description of the work to be subcontracted, location where bid documents can be reviewed, representative of the Prime Bidder to contact, and location, date and time when quotes must be received.
- b. Copies of quotes or responses received from each firm responding to the solicitation.
- c. A telephone log of follow-up calls to each firm sent a solicitation.
- d. For subcontracts where a MWDBE is not considered the lowest responsible sub- bidder, copies of quotes received from all firms submitting quotes for that particular subcontract.
- e. Documentation of any contacts or correspondence to MWDBE, community or contractor organizations in an attempt to meet the goal.
- f. Copy of pre-bid roster.
- g. Letter documenting efforts to provide assistance in obtaining required bonding or insurance for MWDBEs.
- h. Letter detailing reasons for rejection of a MWDBE due to lack of qualification.
- i. Letter documenting proposed assistance offered to MWDBEs in need of equipment, loan capital, lines of credit, or joint pay agreements to secure loans, supplies, or letter of credit, including waiving credit that is ordinarily required.

Failure to provide the documentation as listed in these provisions may result in rejection of the bid and award to the next lowest responsible and responsive Bidder.

Date: \_\_\_\_\_ Name of Authorized Officer: \_\_\_\_\_

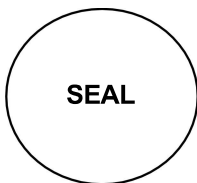

State of North Carolina, County of \_\_\_\_\_  
 Subscribed and sworn to before me this \_\_\_\_\_ day \_\_\_\_\_ 20\_\_\_\_  
 Notary Public \_\_\_\_\_  
 My commission expires \_\_\_\_\_



### Affidavit E: Identification of MWDBE/Local Participation

\_\_\_\_\_  
(Name of Bidder)

I hereby certify that on contract: \_\_\_\_\_

\_\_\_\_\_  
(Name of Project)

We will use the following Minority, Women, and Disadvantaged Business Enterprises (MWDBE), and Local (Cumberland, Hoke, Harnett County) as construction subcontractors, vendors, suppliers, or providers of professional services.

<u>Name, Address, &amp; Phone No.</u>	<u>*MWDBE Category / **Local</u>	<u>NAICS</u>	<u>Dollar Value</u>

\*MWDBE categories: Black-African Americans (B), Hispanic-Americans (H), Asian- Americans (A), Native-Americans (I), Women (F), Socially/Economically Disadvantaged (D)

\*\*Local: Fayetteville Metropolitan Statistical Area (MSA) comprising of Cumberland County, Hoke County, and Harnett County. PWC is requesting this information for reporting purposes only, and use of local entities will not be considered for compliance with the requirements of the MWDBE Program.

The total value of MWDBE/local business contracting will be \$ \_\_\_\_\_

Date: \_\_\_\_\_ Name of Authorized Officer: \_\_\_\_\_

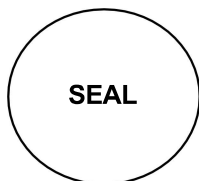

State of North Carolina, County of \_\_\_\_\_

Subscribed and sworn to before me this \_\_\_\_\_ day \_\_\_\_\_ 20\_\_\_\_

Notary Public \_\_\_\_\_

My commission expires \_\_\_\_\_

**FAYETTEVILLE PUBLIC WORKS COMMISSION  
MWDBE ADD / CHANGE FORM**

If a MWDBE subcontractor fails to complete work under the subcontract for any reason, the recipient must require the prime contractor to employ the good faith efforts set forth in the MWDBE Program if soliciting a replacement or additional subcontractor.

**For MWDBE Change Request, please provide all information below:**

Prime Contractor: \_\_\_\_\_

Subcontracted Work: \_\_\_\_\_

Previous Subcontractor: \_\_\_\_\_

Reason this for change request:  
\_\_\_\_\_

New Subcontractor: \_\_\_\_\_ MWDBE Category: \_\_\_\_\_

**To Add MWDBE Subcontractor/Subcontracted work:**

If this is a new trade being subcontracted or a subcontractor that was not documented in the original Project Bid Information submittal, then good faith efforts to solicit a MWDBE must be documented, as the original MWDBE instructions indicate. Please provide all good faith efforts below showing all the MWDBE firms contacted to perform this work along with any additional good faith efforts or evidence that there are not reasonably available firms in the work area. PWC's MWDBE Program requires that good faith efforts are to be carried out to the fullest extent practicable. If solicitations were not carried out due to being impracticable, please attach this explanation to this form.

Name, Address, & Contact Information	MBE or WBE and Certifying agency	How was this firm contacted (email, letter, or Phone) and what was the result of the solicitation? *

\*Must submit copies of emails or letters. If phone calls were made this sheet can serve as documentation of calls

Date: \_\_\_\_\_ Name of Authorized Officer: \_\_\_\_\_



State of North Carolina, County of \_\_\_\_\_

Subscribed and sworn to before me this \_\_\_\_\_ day \_\_\_\_\_ 20\_\_

Notary Public \_\_\_\_\_

My commission expires \_\_\_\_\_

# SMALL LOCAL SUPPLIER / MWDBE SUBCONTRACTOR DISCLOSURE FORM

Contractor: \_\_\_\_\_  
 Address & Phone: \_\_\_\_\_  
 Project: \_\_\_\_\_  
 Name: \_\_\_\_\_  
 Pay Application # \_\_\_\_\_

Please complete the below form by providing the necessary information for the payments made to each subcontractor, vendor, or supplier for the work associated with the identified pay application. This form must be fully completed and attached to each pay application.

Firm Name, Address, and Contact Information	Payment Amount	Type of Work/Commodity (Include NAICS Code)

\_\_\_\_\_  
Signature

\_\_\_\_\_  
Printed Name

\_\_\_\_\_  
Title

\_\_\_\_\_  
Date