

**CONTRACT DOCUMENTS &
TECHNICAL SPECIFICATIONS**

PWC2324054

LIFT STATION REHABILITATION

ISSUED FOR BID

MARCH 5, 2024

**Fayetteville Public Works Commission
Administrative Building
955 Old Wilmington Road
Fayetteville, NC 28301**

TABLE OF CONTENTS

SECTION A – PROJECT SPECIFICS

General

- Advertisement for Bids
- 00100 – Instructions to Bidders

Bid Submittal Documents

- Bid Schedule – Performance and Delivery
- Bid Checklist
- 00300 – Bid Pricing Form
- Contractor Qualification Forms
- Bid Supplemental Forms and Attachments
- Minority, Women, Disadvantaged Business Enterprise (MWDBE) Program
- MWDBE Program Forms
- SLS/MWDBE Disclosure Form

SECTION B – CONTRACT EXECUTION DOCUMENTS

- Notice of Award
- Acceptance of Award
- On-Call Construction Agreement
- PWC General Conditions
- Contract Supplemental Forms and Attachments
- Notice to Proceed

SECTION C – ADMINISTRATIVE PROVISIONS

DIVISION 1 – GENERAL REQUIREMENTS

- 01000 – Supplementary Conditions
- 01025 – Measurement and Payment
- 01300 – Submittals
- 01400 – Quality Control
- 01700 – Project Closeout

SECTION D – TECHNICAL SPECIFICATIONS

DIVISION 2 – SITE WORK

- 02730 - Sanitary Sewer System *rev 1.1.16*
- 02750 - Wastewater Flow Control *rev 9.8.19*
- 02764 - Lift Station Wet Well Lining *rev 6.13.17*
- 09810 - Glass Reinforced Epoxy
- 16010 - Electrical – Lift Stations *rev 1.1.08*

APPENDICES

- LS#11 Neal St
- LS#17 Orange St
- LS#21 Rivercliff #2
- Sales Tax Form

SECTION A – PROJECT SPECIFICS GENERAL

***** THIS PAGE WAS INTENTIONALLY LEFT BLANK *****

**ADVERTISEMENT FOR BID
FAYETTEVILLE PUBLIC WORKS COMMISSION
LIFT STATION REHABILITATION**

**Cumberland County
North Carolina**

Pursuant to N.C.G.S 143-129, sealed bids are solicited and will be received at Fayetteville Public Works Commission, Administration Building, Conference Room 107, 955 Old Wilmington Road, Fayetteville, NC 28301, until **2:00 p.m., EST Thursday, April 4, 2024**, at which time they will be publicly opened and read.

This project consists of rehabilitation of existing sewer lift station wet wells throughout the system. Work shall include repair and preparation of the concrete surface, preparation, and painting of stairs and railings, preparation and painting of piping, miscellaneous electrical and mechanical repairs, bypass pumping, installation of the specified coating system, and all related work necessary to rehabilitate the sewer lift station wet wells. The foregoing description shall not be construed as a complete description of all work required. All work shall be done in accordance with PWC technical specifications and standard contract terms.

A **NON-MANDATORY** pre-bid meeting will be held at **1:00 p.m., EST Wednesday, March 20, 2024**, in the Skills Lab, Fayetteville Public Works Commission, Administrative Building, 955 Old Wilmington Road, Fayetteville, NC 28301. Representatives of the Owner and Project Engineer will be available to answer questions. Any formal bid submitted by a Bidder that fails to attend this meeting will be considered an unresponsive bid.

Questions will be fielded at the pre-bid meeting and all prospective bidders are required to attend the meeting. Individual telephone inquiries are prohibited. PWC assumes no responsibility to fully inform absentees of clarifications not issued by addendum.

Bids must be enclosed in a sealed envelope addressed to Tanya Hazlett, Procurement Advisor, Fayetteville Public Works Commission, 955 Old Wilmington Road, Fayetteville, North Carolina 28301. The outside of the envelope must be marked **SEALED BID: LIFT STATION REHABILITATION** and shall indicate the name, address and state license number of the bidder. Bids shall be submitted on the printed forms, or exact copies thereof, contained in the Contract Documents.

Each bid shall be accompanied by a bid bond of five percent (5%) of the bid executed by a surety company licensed under the laws of North Carolina to execute the Contract in accordance with the bid bond and upon failure to forthwith make payment, the surety shall pay the obligee an amount equal to the amount of said bond. Said deposit shall be retained by the Owner as liquidated damages in event of failure of the successful bidder to execute the Contract within ten (10) days after the Notice of Award or give satisfactory surety as required by law.

Performance and Payment Bonds are required in the amount of 100% of the Contract amount and shall be furnished by the Contractor.

All Contractors are notified that North Carolina Statutory provisions as to licensing of Contractors will be followed as applicable in receiving and evaluating bids and in reading and awarding the Contract (Chapter 87 of the North Carolina General Statutes).

The license classification shall be:

Part 1:	Public Utilities (Water and Sewer)	-	Unlimited
	Unclassified	-	Unlimited

Plans and Specifications including Contract Documents will be available online for viewing and downloading on or about **Tuesday, March 5, 2024**, on the PWC Procurement website at <https://www.faypwc.com/purchasing>. In addition, the documents will be available from the Fayetteville State University Construction Resource Office (FSU CRO) at <https://www.uncfsu.edu/academics/colleges-schools-and-departments/broadwell-college-of-business-and-economics/outreach-centers/construction-resource-office>. In collaboration with the North Carolina Institute of Minority Economic Development, the FSU CRO offers services and support to help small, minority, veteran, and women-owned businesses identify and compete for construction-related projects.

At the FSU CRO, potential bidders may:

- Research, view and print project drawings to scale free of charge;
- Use available software to prepare their bid; and
- Receive certification and pre-qualification assistance.

Please email the FSU CRO to make an appointment: fsucro@uncfsu.edu

Plans and Specifications are also being furnished to ISQFT (www.isqft.com) for online posting. Purchase of the documents is not required to bid.

Fayetteville Public Works Commission reserves the right to reject any or all bids for any reason determined by PWC to be in its best interest, or to award the bid to the lowest responsible bidder or bidders, taking into consideration quality, performance, and the time specified in the bids for the performance of the contract.

The bidder to whom the contract may be awarded must comply fully with the requirements of North Carolina General Statutes Section 143-129, as amended.

No bids may be withdrawn after the scheduled Bid Opening for a period of ninety (90) calendar days.

FAYETTEVILLE PUBLIC WORKS COMMISSION
Victoria McAllister
Procurement Manager

**00100 - INSTRUCTIONS TO BIDDERS
FAYETTEVILLE PUBLIC WORKS COMMISSION
LIFT STATION REHABILITATION**

A. DEFINED TERMS

Terms used in these Instructions to Bidders are defined in the Definitions and Terminology sections of PWC General Conditions.

B. COPIES OF BIDDING DOCUMENTS

1. Complete sets of the Bidding Documents as stated in the Invitation to Bidders, may be obtained from the PWC Procurement Department.
2. Complete sets of Bidding Documents shall be used in preparing Bids. PWC assumes no responsibility for errors or misinterpretations resulting from the use of incomplete sets of Bidding Documents.

C. EXAMINATION OF CONTRACT DOCUMENTS, OTHER RELATED DATA, AND PROJECT SITE

1. Before submitting a Bid, each Bidder shall (a) examine the Contract Documents thoroughly, (b) visit the site and become familiar with the site and any local conditions that may in any manner affect the cost, progress, or performance of the Work, (c) be familiar with federal, state and local laws, ordinances, rules and regulations that may in any manner affect cost, progress or performance of the Work, and (d) study and carefully correlate Bidder's observations with the Contract Documents, and (e) give the PWC Procurement Advisor written notice of all conflicts, errors or discrepancies in the Contract Documents.
2. Bidders should consult the Specifications for the identification of those reports of investigations and tests of subsurface and latent physical conditions at the site or reports that otherwise may affect cost, progress, or performance of the Work which may have been utilized in the preparation of the Drawings and Specifications. PWC will make copies of such reports if available at the cost (non-refundable) of reproduction to any Bidder requesting them. These reports are not intended to constitute any explicit or implicit representation as to the nature of the subsurface and latent physical conditions, which may be encountered at the site or to constitute explicit or implicit representations as to any other matter, contained in any report. Such reports are not guaranteed as to accuracy or completeness and are not part of the Contract Documents. Before submitting a Bid, each Bidder will, at its own expense, make such investigations and tests as the Bidder may deem necessary to determine his Bid for the performance of the Work in accordance with the Contract Documents.
3. On request (minimum 48 hours advance notice), PWC will provide each Bidder access to the site to conduct such investigations and tests, as each Bidder deems necessary for submission of its Bid.
4. The lands upon which the Work is to be performed, right-of-way for access thereto, and other lands available for use by the Contractor in performing the Work are identified in the Contract Documents.

5. The submission of a Bid constitutes an incontrovertible representation by the Bidder that it has complied with every requirement of this Section and that the Contract Documents are sufficient in scope and detail to indicate and convey an understanding of all terms and conditions for the performance of the Work.

D. INTERPRETATIONS AND ADDENDA

1. All questions about the meaning or intent of the bid or Contract Documents shall be submitted in writing to Tanya Hazlett, Procurement Advisor, by email to procurement@faypwc.com. In order to receive consideration, questions must be received by **Friday, March 22, 2024 and time 5:00 p.m.** Any interpretations of questions so raised, which in the opinion of the Project Engineer require interpretations, will be issued by Addenda via email or posted online by the Owner and/or Project Engineer. An Addendum extending the Bid Opening date may be issued up to five (5) business days before the Bid Opening date. An Addendum withdrawing the Invitation for Bid may be issued any time prior to the Bid Opening date. The Owner and Project Engineer will not be responsible for oral interpretations or clarifications, which anyone presumes to make on their behalf.

Bidders are expressly prohibited from contacting any PWC official or employee associated with this project, except as noted above. Violation of this prohibition is grounds for the immediate disqualification of the bidder.

2. PWC may issue such additional Addenda as may be necessary to clarify, correct, or change the Contract Documents. Such Addenda, if any, will be issued in the manner and within the time stated in Paragraph 1 of this Section.
3. Each Bidder shall be responsible for determining that all Addenda issued by PWC have been received before submitting a Bid for the Work.
4. Each Bidder shall acknowledge the receipt of each Addendum on the Bid Form.

E. QUALIFICATION OF CONTRACTORS

1. **Bidder Qualification Form** – The Bid package shall include the completed Contractor Qualification Form and all supporting documentation.
2. **Statutory Requirements** – The Bidder shall comply with all federal, state, and local statutes, regulations, and codes as they relate to the Project. Failure to comply with these requirements shall be considered a breach of Contract.

F. SUBSTITUTE MATERIAL AND EQUIPMENT

The Contract, if awarded, will be on the basis of material and equipment described in the Drawings or required in the Specifications without consideration of possible substitute or "or-equal" items. The procedure for submittal of substitute or "or-equal" items for consideration is set forth in the PWC General Conditions.

G. CONTRACTOR'S LICENSE

1. No General Contractor shall engage in contracting work in the State of North Carolina unless it has been licensed under in accordance with North Carolina law.
2. Bidders are prohibited from contracting for, or bidding upon, the construction, removal,

repair or improvements to or upon real property owned, controlled or leased by Fayetteville Public Works Commission without a North Carolina Contractor's License.

3. Each bidder shall indicate its North Carolina Contractor's License number on the bid envelope and the Bid Form.
4. License Classification shall be:
 - Public Utilities Water and Sewer: Unlimited
 - Unclassified: Unlimited

H. SUBCONTRACTORS

1. Contractor shall subcontract no more than 49 percent (49%) of the value of the Contract.
2. Each Bidder shall submit to PWC with its bid the List of Subcontractors, Suppliers, other persons, and organizations proposed for those portions of the Work for which such identification is required. If PWC, after due investigation has reasonable objection to any proposed Subcontractor, Supplier, other person or organization, PWC may, before Notice of Award is given, request apparent Successful Bidder to submit an acceptable substitute without an increase in the Bid.
3. If the apparent Successful Bidder declines to make such a substitution, PWC may award the Contract to the next lowest responsive, responsible Bidder that proposes to use acceptable Subcontractors, Suppliers, and other persons, and organizations. The declining to make requested substitutions will not constitute grounds for sacrificing the bid security of any Bidder. If PWC does not make written objection to a Bidder's list of Subcontractors, Suppliers, other persons, or organizations prior to giving Notice of Award, the list will be considered acceptable, subject to revocation as provided in the PWC General Conditions.

I. MINORITY, WOMEN, DISADVANTAGED BUSINESS ENTERPRISE (MWDBE PROGRAM)/SMALL LOCAL SUPPLIER (SLS) PROGRAM

1. PWC is committed to promoting the utilization of Minority, Women, and Disadvantaged Businesses in PWC's geographical statistical area (GSA) by providing equal opportunity for participating in all aspects of PWC's contracting and procurement programs. The GSA consists of NCDOT division areas 3-8, and 10. PWC is also committed to promoting the utilization of small, local businesses in the Fayetteville Metropolitan Statistical Area (MSA) by increasing opportunities for those businesses to participate in PWC procurements. The MSA consists of Cumberland County, Hoke County, and Harnett County.
2. PWC requires Bidders to report efforts to utilize Minority, Women, and Disadvantaged Business Enterprises (MWDBEs) and Historically Underutilized Businesses (HUBs) for specific projects and requires all Bidders to report all such efforts for MWDBEs, HUBs, and Small Local Suppliers regardless of the requirements of a specific project. **Bidders shall document any good-faith efforts and utilization in the MWDBE forms provided within the Contract Documents.**
3. NCDOT Disadvantaged Business Enterprise (DBE) and NC Department of Administration (DOA) Historically Underutilized Business (HUB) firms with current

certifications are acceptable for listing in the bidder's submittal of MWDBE participation and will be considered to meet any necessary contract goal. Firms that are certified through NCDOT are listed in the "Vendor Directory" which can be accessed through the following: <https://www.ebs.nc.gov/VendorDirectory/default.html>. Firms that are certified through NC DOA are listed at the "Vendor Search" which can be accessed through the following link: <https://evp.nc.gov/vendors/vendorsearchadvanceform/?id=d98aa5d6-0d57-ee11-be6e-001dd804e775>.

4. Bidders shall submit, with their bid, the MWDBE documentation required in the Contract Documents. The Bidder is strongly recommended to attend the Pre-Bid Meeting, as important information will be reviewed.

J. SUBMISSION OF BIDS

1. All Bidders shall use the enclosed Bid Forms, or exact copies thereof, in submitting their bid prices. PWC will not accept oral Bids or Bids received by telephone, email, or telecopier (FAX machine) for this Bid.
2. All prices must be F.O.B. delivered to the point as indicated by this Bid. PWC will grant no allowance for boxing, crating, or delivery unless specifically provided for in this Bid.
3. The Bid Form must be completed in black ink. Black or blue pen ink is acceptable if handwritten. Discrepancies between amounts shown in words and amounts shown in figures will be resolved in favor of the amounts shown in words. Discrepancies in the multiplication of units of Work and the unit prices will be resolved in favor of the correct multiplication of the unit prices. Discrepancies between the indicated sum of any column of figures and the correct sum thereof will be resolved in favor of the correct sum.
4. Bid submittals sent by mail should be registered mail. The sealed Bid, marked as indicated above, should be enclosed in an additional sealed envelope similarly marked and addressed to:

Fayetteville Public Works Commission
Attn: Tanya Hazlett, Procurement Advisor
955 Old Wilmington Road
Fayetteville, North Carolina 28301

5. Mark the envelope in the lower left-hand corner with the project title, hour and due date of Bid, and the Bidder's North Carolina contractor registration number.
6. Bids sent by mail and arriving after the time for the opening of Bids shall not be considered valid Bids. In such instances, the Bidders shall have no claim against PWC.
7. All items contained in the Bid Checklist shall be completely filled out and submitted with the bid. Failure to submit any of the items requested with the Bid Form may be just cause for rejection of the Bid by PWC.
8. All erasures, insertions, additions, and other changes made by the Bidder to the Bid Form shall be signed or initialed by the Bidder. Bids containing any conditions, omissions, erasures, alterations, or items not called for in the Bid, may be rejected by PWC as being incomplete or nonresponsive.
9. The Bid Form must be signed in order to be considered. If the Bidder is a corporation, the

Bid must be submitted in the name of the corporation, not simply the corporation's trade name. In addition, the Bidder must indicate the corporate title of the individual signing the Bid.

10. The Bid Form, the Bid security, if any, and any other documents required, shall be enclosed in a sealed opaque envelope. Any notation or notations on the exterior of the envelope purporting to alter, amend, modify, or revise the bid contained within the envelope shall be of no effect and shall be disregarded.
11. All Bids received in the Procurement Department by the deadline indicated will be kept sealed until the time and date of the Bid Opening.
12. All late Bids shall be returned unopened to the sender.

K. BID BOND

1. Each Bid shall be accompanied by an acceptable Bid bond in the amount of five percent (5%) of the Bid amount, and made payable to Fayetteville Public Works Commission, North Carolina.
2. The Bid bond is a guarantee that if the contract is awarded by PWC to the Bidder, the Bidder shall enter into the contract with PWC for the work mentioned in this Bid or forfeit the Bid bond to PWC, not as a penalty, but as liquidated damages.
3. No forfeiture under a Bid bond shall exceed the lesser of (a) the difference between the Bid for which the Bid bond was written and the next low Bid of another Bidder, or (b) the face amount of the Bid bond.
4. All bonds shall be executed by a surety company selected by the Bidder, which is legally authorized to do business in the State of North Carolina (NCGS §44 A-26), and the bond shall be the same in both form as well as substance as AIA Document A310, Bid Bond.
5. The Bidder shall require the attorney-in-fact, who executed the required bond on behalf of the surety company, to affix thereto a certified and current copy of the power of attorney.
6. The bond premium shall be paid by the Bidder and the cost shall be included in the Bid price.
7. Any inspection of procurement transaction records shall be subject to reasonable restrictions to ensure the security and integrity of the records.

L. OPENING OF BIDS

1. Bids will be opened publicly and read aloud on the date and time set for the Bid Opening in the Notice to Bidders.
2. Any Bidder, upon request, shall be afforded the opportunity to inspect Bid records within a reasonable time after the opening of all Bids but prior to award, except in the event that PWC decides not to accept any of the Bids and to reopen the contract. Otherwise, bid records shall be open to public inspection only after the award of the Contract.
3. Any inspection of procurement transaction records shall be subject to reasonable restrictions to ensure the security and integrity of the records.

M. MODIFICATION OF BIDS

1. A Bid may be modified or withdrawn by the Bidder at any time prior to the time and date set for the Bid Opening. The Bidder shall notify the PWC Procurement Department in writing of its intentions.
2. Modified and withdrawn Bids may be resubmitted to the PWC Procurement Department up to the time and date set for the Bid Opening.

N. WITHDRAWAL OF BID DUE TO ERROR

1. If the Bidder desires to withdraw its Bid, the Bidder must do so before the time fixed for the opening, without prejudice, by communicating its purpose in writing to PWC. After bids are open, bids may only be withdrawn in strict accordance with N.C.G.S. Section 143-129-1

O. BIDS TO REMAIN OPEN

1. All Bids shall remain open for ninety (90) calendar days after the day of the Bid Opening.

P. ESTIMATED QUANTITIES

1. The estimated quantities contained herein in certain items in the Bid are for the purpose of comparing bids, and while they are believed to be close approximations, they are not guaranteed, and settlement will be made on the basis of the work as actually executed at the unit prices in the Bid as accepted. PWC further reserves the right to delete any single line item or combination of items from the bid and cannot guarantee that all quantities listed in the Contract Documents will be utilized.
2. The Contractor should verify quantities before submitting a bid. Due to conditions that may be found under pavement such as the accurate location of existing water lines, sewer lines, gas lines, and structure services of all types, quantities are subject to change during construction, but this contingency shall not be used for a claim to change unit prices submitted in the Bid.

Q. CONTRACT PERIOD

This contract will be effective for a period of one (1)-year from the date of award. At PWC's option, this Contract may be renewed for a maximum of two (2) one (1) year contract periods. Near the end of the initial contract period, PWC maintains the option to renew the contract for an additional contract period if:

- The Contractor's workmanship, performance and production rate are satisfactory,
- Funding is available
- Both parties agree to the renewal, and
- There is a need for the work

R. UNIT PRICING

All unit prices submitted herein shall be firm against any increase for the initial one-year contract period.

If the contract is renewed for an additional contract period, the Contractor may request that each unit price be increased/decreased, based on the most recently published Engineering

News Record Construction Cost Index for the annual change, not to exceed 3.0%, whichever is lower. PWC shall receive the Contractor's request for a unit price adjustment no later than 15 days prior to end of contract year, or the next business day, should the 15th day prior to end of contract year fall on a weekend. Failure to submit the request 15 days prior to end of contract year will result in the contract being renewed at the same unit prices.

The request for increase may be submitted with PWC reserving the right to accept or reject the increase or cancel the Contract. Such action by PWC shall occur not later than 15 business days after receipt of a properly documented request for price increase. Any increases accepted by the PWC shall become effective the month following approval and be valid for a minimum of one contract year.

S. AWARD OF CONTRACT

1. PWC reserves the right to reject any and all Bids, to waive any and all informalities, and to disregard all nonconforming, nonresponsive, or conditional Bids. PWC reserves the right to request additional information from any or all bidders for evaluation purposes. Failure or refusal to furnish additional information as requested may result in the rejection of the bid.
2. In case of a tie Bid, the tie shall be decided by lot.
3. It is the intent of PWC to recommend the award of this contract to the lowest responsive, responsible Bidder provided the Bid has been submitted in accordance with the requirements of the Bidding Documents and does not exceed the funds available. In determining the lowest responsible Bidder, PWC may consider, among other criteria, the Bidder's past performance conduct on other contracts, and other information provided by the Bidder as noted below.
4. In determining the lowest responsive Bidder, PWC will evaluate the Bidder's proposed Bid price and the completeness of the submitted bid in accordance with the requirements of the Contract Documents.
5. PWC may consider the operating costs, maintenance considerations, performance date, and guarantees of materials and equipment.
6. PWC may conduct such investigations as deemed necessary to assist in the evaluation of any Bid and to establish the responsibility, qualifications and financial ability of the Bidders, as well as other considerations, to include but not limited to resources available to the Bidder to perform the work effectively, proposed Subcontractors and other persons and organizations to do the work in accordance with the Contract Documents to PWC's satisfaction within the prescribed time.
7. PWC reserves the right to reject the Bid of any Bidder who does not pass any such evaluation to PWC's satisfaction.
8. If the Contract is to be awarded, PWC will give the Successful Bidder a Notice of Award within ninety (90) days after the day of the Bid Opening.
9. The Bidder to whom the contract is awarded shall, within ten (10) days after prescribed documents are presented for signature, execute and deliver the Contract Documents and

any other forms or bonds required by the Bid to PWC.

10. The Bidder is required to complete the attached forms that will allow PWC to verify that the Bidder is qualified to perform the Work described in these Contract Documents. All forms shall be completed and submitted with the Bid. Failure to submit all the required forms shall be considered grounds for PWC to reject the bid.

PWC will review all of the bids and qualification data to determine the lowest responsive, responsible Bidder. PWC reserves the right to not award the Contract to the lowest bidder if the information provided is not complete, does not meet the satisfaction of PWC, or has been falsified. PWC will not request any additional information in order to allow the Contractor to complete bid.

11. During the evaluation phase, bid submittals will be reviewed to ascertain which bids technically and otherwise address all the requirements of these Contract Documents. Bid submittals determined to be technically non-responsive or not sufficiently responsive may be disqualified.

The Bidder shall address each of the Evaluation Criteria as requested in the Technical Evaluation Criteria Form located within Section A Project Specifics Bid Submittal Documents. To be considered substantive, the information must respond to all requirements.

12. PWC may conduct such investigations/verifications as deemed necessary to establish the responsibility, qualification and financial ability of the Bidder. Should PWC find that the apparent low bidder is not the lowest responsive, responsible bidder by integrity of the information furnished, said apparent low bidder will be so notified and its bid bond shall be returned without prejudice. Failure or refusal to furnish any items of information requested by PWC shall be considered as non-responsive and therefore basis for rejection of the bid.

T. TAXES

1. The Successful Bidder shall pay all county, city, state and federal taxes required by laws in effect at the time Bids are received and resulting from the Work or traceable thereto, under whatever name levied.
2. Said taxes shall not be in addition to the contract price between PWC and the Successful Bidder. The taxes shall be an obligation of the Successful Bidder and not of PWC. PWC shall be held harmless from same by the Successful Bidder.

U. PERFORMANCE AND OTHER BONDS

1. The PWC General Conditions set forth PWC's requirements as to Performance and other Bonds.

V. E-VERIFY REQUIREMENTS

1. Contractor hereby acknowledges that "E-Verify" is the federal E-Verify program operated by the US Department of Homeland Security and other federal agencies which is used to verify the work authorization of newly hired employees pursuant to federal law and in accordance with Article 2, Chapter 64 of the North Carolina General Statutes.

2. Contractor further acknowledges that all employers, as defined by Article 2, Chapter 64 of the North Carolina General Statutes, must use E-Verify and after hiring an employee to work in the United States, shall verify the work authorization of the employee through E-Verify in accordance with NCGS §64-26(a).
3. Contractor hereby pledges, attests and warrants through execution of this Agreement that Contractor complies with the requirements of Article 2, Chapter 64 of the North Carolina General Statutes and further pledges, attests and warrants that any subcontractors currently employed by or subsequently hired by Contractor shall comply with any and all E-Verify requirements. Failure to comply with the above requirements shall be considered a breach of this Agreement.

W. IRAN DIVESTMENT ACT

1. As mandated by N.C.G.S. 147-86.59(a), the Contractor hereby certifies that it is not listed on the Final Divestment List created by the North Carolina State Treasurer pursuant to N.C.G.S. 147-86.58. Contractor further certifies that in accordance with N.C.G.S. 146-86.58(b) that it shall not utilize any subcontractor found on the State Treasurer's Final Divestment List. Contractor certifies that the signatory to this Purchase Order authorized by the Contractor to make the foregoing statement.

*** END OF SECTION ***

**SECTION A – PROJECT SPECIFICS
BID SUBMITTAL DOCUMENTS**

**BID SCHEDULE – PERFORMANCE AND DELIVERY
FAYETTEVILLE PUBLIC WORKS COMMISSION
LIFT STATION REHABILITATION**

(NON-MANDATORY)

Fayetteville Public Works Commission
Administrative Building - Skills Lab
955 Old Wilmington Road
Fayetteville, NC 28301

Deadline for Questions from
Bidders¹

5:00 p.m., Friday, March 22, 2024

Deadline for Addenda issued by
PWC Procurement Department and
Project Engineer²

5:00 p.m., Friday, March 29, 2024

Bid Opening (Submittal Deadline)

2:00 p.m., Thursday, April 4, 2024

Fayetteville Public Works Commission
Administrative Building
Conference Room 107
955 Old Wilmington Road
Fayetteville, NC 28301

Target Commission Meeting

Wednesday, April 24, 2024

Target City Council Meeting

Monday, May 13, 2024

Contract Time:

Annual - One (1) year from NTP with option
for two (2) renewals

Liquidated Damages:

N/A

Bid Acceptance Period

Within ninety (90) Calendar Days unless
otherwise noted

-
1. Questions regarding this bid must be submitted in writing to the attention of Tanya Hazlett, Procurement Advisor, by email to procurement@faypwc.com.

Bidders are expressly prohibited from contacting any FPWC official or employee associated with this Invitation to Bid, except as noted above. Violation of this prohibition is grounds for the immediate disqualification of the bidder.

2. Any addenda to these Contract Documents will be issued by the Project Engineer no later than the date and time stated above.

BID SUBMITTAL CHECKLIST

- 1. Enter Contractor's License Number where called for in the Bid Form and on the outside of the sealed envelope containing the Bid.
- 2. Photocopy of Contractor's License.
- 3. Bid Bond
- 4. Bid Forms Section 00300.
- 5. Provide the responsible North Carolina Registered Agent for Insurance Claims. Include contact information.
- 6. Provide the proposed responsible Bonding Company name. Include contact information.
- 7. List of proposed Subcontractors and material suppliers exceeding 5% of the Contract Value.
- 8. Non-Collusive Affidavit.
- 9. Nondiscrimination Clause.
- 10. Affidavit of Organization and Authority and Sworn Statement.
- 11. Equal Employment Opportunity Acknowledgment.
- 12. Certification regarding Debarment, Proposed Debarment, and other Responsible Matters.
- 13. FTA Certification Regarding Lobbying.
- 14. Affidavit A – Listing of Good Faith Efforts, et al.
- 15. Affidavit B – (Only if the Contractor will perform **ALL ELEMENTS OF THE WORK** on this project with their own forces **AND** will complete **ALL ELEMENTS OF THIS PROJECT WITHOUT THE USE OF SUBCONTRACTORS, MATERIAL SUPPLIERS, OR PROVIDERS OF PROFESSIONAL SERVICES.**
- 16. Affidavit E – Identification of Minority Business Participation Form.
- 17. Small Local Supplier/MWDBE Disclosure Form
- 18. The Completed Contractor Qualification Form.

FAILURE TO SUBMIT THE ABOVE FORMS WITH THE BID FORM MAY BE JUST CAUSE FOR REJECTION OF THE BID BY THE OWNER

***** THIS PAGE INTENTIONALLY LEFT BLANK *****

00300 - BID FORM

TO: **Fayetteville Public Works Commission**
Attn: Tanya Hazlett, Procurement Advisor
955 Old Wilmington Road
Fayetteville, North Carolina 28301

PROJECT: **LIFT STATION REHABILITATION**

FROM: BIDDER _____

ADDRESS _____

DATE OF BID _____, 20 ____

- A. The undersigned BIDDER proposes and agrees, if this Bid is accepted, to enter into a Contract with OWNER in the form included in the Contract Documents to perform and furnish all Work (as that term is defined in the Construction Agreement) specified or indicated in the Contract Documents for the Contract Price and within the Contract Time indicated in this Bid and in accordance with the Contract Documents.
- B. BIDDER accepts all of the terms and conditions of the Instructions to Bidders, including, without limitation, those dealing with the disposition of payment and performance bonds, and insurance certificates. This bid will remain open for ninety (90) calendar days after the day of Bid opening. BIDDER will sign the Contract and submit the Contract Security and other documents required by the Contract Documents within ten (10) days after the date of receipt by the BIDDER.
- C. In submitting this Bid, Bidder represents, as more fully set forth in the Contract, that:
 - 1. BIDDER has examined copies of all the Contract Documents and of the following addenda, receipt of all which is acknowledged on the bid summary page:
 - 2. BIDDER has examined the site and locality where the Work is to be performed, the legal requirements (federal, state, and local laws, ordinances, rules and regulations) and the conditions affecting cost, progress of performance of the work and has made such independent investigations as BIDDER deems necessary.
 - 3. BIDDER acknowledges that OWNER does not assume responsibility for the accuracy of dimensions or completeness of information and data shown or indicated in the Bidding Documents with respect to existing facilities.
 - 4. BIDDER has carefully studied all reports of explorations and tests of subsurface conditions at or contiguous to the site of the Work (except underground facilities) and all drawings of physical conditions in or relating to existing surface or

subsurface structures, pipelines, and utilities at or contiguous to the site are provided within these Contract Documents. Geotechnical Reports and other information regarding subsurface conditions are identified in the attached appendices and detailed in Article V of the PWC General Conditions. BIDDER acknowledges that the OWNER does not assume responsibility for the accuracy or completeness of information and data shown or indicated in the Bidding Documents with respect to underground facilities at or contiguous to the site of Work. BIDDER had obtained and carefully studied (or assumes responsibility for have done so) all such additional or supplementary examinations investigations, explorations, tests, studies, and data that are necessary to identify and understand conditions (surface, subsurface, and underground facilities) at or contiguous to the site of Work or otherwise which may affect cost, progress, performance, or furnishing the Work or which relate to any aspect of means, methods, techniques, sequences, and procedures of construction to be employed by Bidder and safety precautions and programs incident thereto. BIDDER waives all rights to claim that any additional examinations, investigations, explorations, tests, studies, or data are necessary for the proper submission of the Bid for the performance and furnishing of the Work in accordance with the Contract Time, Contract Price, and other terms and conditions of the Contract Documents.

5. BIDDER hereby certifies that, if awarded the Contract for construction of the Project, it will take all possible actions to minimize costs to the OWNER which are related to any disruptions in any part of the Work resulting from unforeseeable conditions which may be encountered and work changes or additions which may be made.
6. BIDDER has correlated the information known to BIDDER, information and observations obtained from visits to the site, reports and drawings identified in the Contract Documents, and all additional examinations, investigations, exploration, tests, studies, and data with the Contract Documents.
7. BIDDER has given OWNER written notice of all conflicts, errors, ambiguities, or discrepancies that BIDDER has discovered in the Contract Documents and the written resolution thereof by OWNER is acceptable to BIDDER, and the Contract Documents are generally sufficient to indicate and convey understanding of all terms and conditions for performing and furnishing the Work for which this Bid is submitted.
8. By bidding in response to this invitation, the BIDDER represents that in the preparation and submission of this Bid, said BIDDER did not, either directly or indirectly, enter into any combination or arrangement with any person, firm or corporation or enter into any agreement, participate in any collusion, or otherwise take any action in the restraint of free, competitive bidding in violation of the Sherman Act (15 U.S.C. Section 1).
9. Bid form must be completed in blue or black ink or by typewriter. The Bid price of each item on the form must be stated in both words and numerals. In case of a

conflict, words shall take precedence. Discrepancies in the multiplication of units of work and unit prices will be resolved in favor of the correct multiplication of the unit prices. Discrepancies between the indicated sum of any column of figures and the correct sum thereof will be resolved in favor of the correct sum.

10. BIDDER understands that the award of contract will be made on the basis of the total Bid amount which will be determined as the sum of the unit price and lump sum Bid Items.
11. BIDDER understands that quantities are estimated and are not guaranteed; they are solely for comparing Bids and establishing the total Bid amount. The Price will be modified by Change Order, and final payment will be based on the quantities of work actually furnished and installed by the successful BIDDER.
12. BIDDER shall complete the Work for the prices indicated on the next page.

Item No.	Ref. No.	Item	Estimated Quantities	Unit	Unit Price	Cost Extension
1	L-1	Mobilization	1	L.S.	\$10,000.00	\$10,000.00
2	L-2	Traffic Control	1	L.S.		
3	U-1	Wet Well Cleaning	500	S.F.		
4	U-2	Rehabilitate Wet Well Utilizing an Elastomeric Lining	5100	S.F.		
5	U-3	Paint Pumps and Piping	150	S.F.		
6	U-4	Grout Leaks Utilizing an Injection Grout	100	GAL.		
7	U-5	Bypass Pumping	1	DAY		
8	L-3	Contingency	1	L.S.	\$75,000.00	\$75,000.00

TOTAL BASE BID \$_____

- BID SUMMARY-

TOTAL BASE BID \$ _____

The BIDDER has received, acknowledged, and used the following addenda in completing the Bid. (Initial and Date as appropriate).

Addendum No. 1	Date _____
Addendum No. 2	Date _____
Addendum No. 3	Date _____
Addendum No. 4	Date _____
Addendum No. 5	Date _____
Addendum No. 6	Date _____
Addendum No. 7	Date _____

The undersigned BIDDER _____ (Contractor Name) certifies that they are licensed as a Contractor under N.C.G.S § 87, and that their license number is _____ (License Number).

The undersigned BIDDER hereby agrees to accept an award of the Contract based on the Total Contract Amount as accepted by the OWNER and as indicated on the Notice of Award.

A. BIDDER agrees that Work shall be completed within the time frame indicated in the Agreement as follow:

1. All work described herein to be complete, including restoration and all punch list items, one (1) year from Notice to Proceed.
2. The BIDDER acknowledges that time is of the essence in this Contract and that the OWNER will suffer financial loss if the Work is not complete within the time specified in Paragraph D.1 above plus any extensions thereof allowed in accordance with these Contract Documents. BIDDER also recognizes the delays, expense and difficulties involved in proving in a legal proceeding the actual loss suffered by the OWNER if the Work is not complete on time. The Bidder agrees to diligently pursue all available work and complete all work in an expeditious manner.

B. The following documents are attached to and made part of this bid:

Required Bid Security in the form of either a cashier's check or certified check or Bid Bond in the amount of 5% of maximum Bid price.

C. Communications concerning this Bid shall be addressed to: (CONTRACTOR's Name, Address and Telephone Number)

D. The terms used in this Bid which are defined in Definitions and Terminology Section of the PWC General Conditions or as otherwise specifically defined in the Contract Documents have the meanings assigned to them therein, which are incorporated by reference as if fully set forth herein.

E. An individual contractor is required to furnish his social security number and sole proprietorship, partnership and corporation are required to furnish their employer identification numbers to Fayetteville Public Works Commission. Please indicate this information on this Bid Form as follows:

Social Security Number: _____

Federal Employer Identification Number: _____

SUBMITTED ON ____ day of _____ 2024

AN INDIVIDUAL

BY: _____ (SEAL)

(Individual's Name and Signature)

Doing Business as: _____

North Carolina Contractor Registration Number: _____

Business Address: _____

Phone Number: _____

Subscribed and sworn to before me this ____ day of _____ 2024

NOTARY PUBLIC

My Commission Expires: _____

A PARTNERSHIP

BY: _____ (SEAL)

(Firm Name)

(General Partner and Signature)

North Carolina Contractor Registration Number: _____

Business Address: _____

Phone Number: _____

Subscribed and sworn to before me this ____ day of _____ 2024

NOTARY PUBLIC

My Commission Expires: _____

A CORPORATION

BY: _____
(Corporation Name) (State of Incorporation)

BY: _____ (SEAL)
(Name and Title of Person Authorized to Sign and Signature)

ATTEST: _____
(Secretary or Assistant Secretary and Signature)

North Carolina Contractor Registration Number: _____

Business Address: _____

Phone Number: _____

Subscribed and sworn to before me this ____ day of _____ 2024

NOTARY PUBLIC
My Commission Expires: _____

A JOINT VENTURE

BY: _____
(Name and Signature)

Doing Business as: _____

North Carolina Contractor Registration Number: _____

Business Address: _____

Phone Number: _____

Subscribed and sworn to before me this ____ day of _____ 2024

NOTARY PUBLIC
My Commission Expires: _____

(Each joint venturer must sign. The name of signing for each individual, partnership, and corporation that is a party to the joint venture should be in the manner indicated above.)

LIFT STATION REHABILITATION CONTRACTOR QUALIFICATION FORM

*****MUST BE COMPLETED AND INCLUDED WITH BID*****

Fayetteville PWC reserves the right to request information from the contractor to complete its assessment of the contractor or subcontractors qualifications. Partially complete forms may be considered non-responsive based on the quantity and quality of information provided. Wholly incomplete forms will be considered non-responsive and will result in rejection of the bid.

CONTRACTOR DOCUMENTATION

(1) Name of Prime Contractor and NC License Number :	Name: NC License No.:
a. Within the last five (5) years , has the contractor been involved in any judgments, claims, or arbitration with regard to construction contracts If so, provide list and describe each event fully. Attach additional information, as necessary.	<input type="checkbox"/> Yes (provide list and describe each event fully) <input type="checkbox"/> No
b. Within the last five (5) years , has any officer or principal of the organization ever been an officer or principal of another organization when it failed to complete a construction contract? If so, provide list and describe each event fully. Attach additional information, as necessary.	<input type="checkbox"/> Yes (provide list and describe each event fully) <input type="checkbox"/> No
(2) Name of Sewer Bypass Subcontractor (if applicable) (If Prime Contractor intends to complete all work, skip to Item 3)	Name:
a. Within the last five (5) years , has the subcontractor been involved in any judgments, claims, or arbitration with regard to construction contracts If so, provide list and describe each event fully. Attach additional information, as necessary.	<input type="checkbox"/> Yes (provide list and describe each event fully) <input type="checkbox"/> No
b. Within the last five (5) years , has any officer or principal of the subcontractor's organization ever been an officer or principal of another organization when it failed to complete a construction contract? If so, provide list and describe each event fully. Attach additional information, as necessary.	<input type="checkbox"/> Yes (provide list and describe each event fully) <input type="checkbox"/> No
(3) Provide list of other Subcontractors and field of specialty (cleaning, electrical, mechanical, etc.), if applicable. Additional subcontractors can be attached to the qualifications form, if necessary.	
a. Subcontractor Name:	
Specialty:	
b. Subcontractor Name:	
Specialty:	

LIFT STATION REHABILITATION CONTRACTOR QUALIFICATION FORM

*****MUST BE COMPLETED AND INCLUDED WITH BID*****

Fayetteville PWC reserves the right to request information from the contractor to complete its assessment of the contractor or subcontractors qualifications. Partially complete forms may be considered non-responsive based on the quantity and quality of information provided. Wholly incomplete forms will be considered non-responsive and will result in rejection of the bid.

c. Subcontractor Name:	
Specialty:	
d. Subcontractor Name:	
Specialty:	

PRIME CONTRACTOR COATING EXPERIENCE AND RESOURCES

- a. The Contractor shall be trained and certified to apply the proposed lining system with a minimum of **five (5) years** of experience in applying the proposed lining system. All certifications shall be current.
- b. The Contractor shall be fully qualified, experienced and equipped to complete the work within the time specified and in a satisfactory manner. The Contractor shall provide not less than **four (4) completed coating projects** of similar scope and nature. A minimum of two (2) of the projects shall have been completed within the past **four (4) years**. The Contractor shall have successfully installed the proposed lining system in concrete structures totaling a **minimum of 80,000 square feet** and shall have a **minimum of four (4) years' service** in the ground. Include the dates of such projects. The client's representative, name, and telephone numbers shall be provided for reference of each project listed. Contractor shall provide references for the Owner to verify project information. Each project should be from separate references. Additional similar projects may be attached at the Contractor's discretion.

1. Project Name:			
Location:			
Superintendent:			
Facility (MH, wet well, etc.):		Area (SF):	
Coating Manufacturer:		Name of Coating Applied:	
Start Date:		End Date:	
Cost:			
Client:			
Client Contact Name:			
Client Phone:			
Scope/Additional Information:			
Cementitious base applied (Y/N)?			
Subcontractor completing bypass pumping (if applicable):			
2. Project Name:			
Location:			
Superintendent:			
Facility (MH, wet well, etc.):		Area (SF):	
Coating Manufacturer:		Name of Coating Applied:	
Start Date:		End Date:	

LIFT STATION REHABILITATION CONTRACTOR QUALIFICATION FORM

*****MUST BE COMPLETED AND INCLUDED WITH BID*****

Fayetteville PWC reserves the right to request information from the contractor to complete its assessment of the contractor or subcontractors qualifications. Partially complete forms may be considered non-responsive based on the quantity and quality of information provided. Wholly incomplete forms will be considered non-responsive and will result in rejection of the bid.

Cost:			
Client:			
Client Contact Name:			
Client Phone:			
Scope/Additional Information:			
<p>Cementitious base applied (Y/N)?</p> <p>Subcontractor completing bypass pumping (if applicable):</p>			
3. Project Name:			
Location:			
Superintendent:			
Facility (MH, wet well, etc.):	Area (SF):		
Coating Manufacturer:	Name of Coating Applied:		
Start Date:	End Date:		
Cost:			
Client:			
Client Contact Name:			
Client Phone:			
Scope/Additional Information:			
<p>Cementitious base applied (Y/N)?</p> <p>Subcontractor completing bypass pumping (if applicable):</p>			
4. Project Name:			
Location:			
Superintendent:			
Facility (MH, wet well, etc.):	Area (SF):		
Coating Manufacturer:	Name of Coating Applied:		
Start Date:	End Date:		
Cost:			
Client:			
Client Contact Name:			
Client Phone:			
Scope/Additional Information:			

LIFT STATION REHABILITATION CONTRACTOR QUALIFICATION FORM

*****MUST BE COMPLETED AND INCLUDED WITH BID*****

Fayetteville PWC reserves the right to request information from the contractor to complete its assessment of the contractor or subcontractors qualifications. Partially complete forms may be considered non-responsive based on the quantity and quality of information provided. Wholly incomplete forms will be considered non-responsive and will result in rejection of the bid.

Cementitious base applied (Y/N)?

Subcontractor completing bypass pumping (if applicable):

SUPERINTENDENT EXPERIENCE AND RESOURCES

a. Provide the name of the proposed prime contractor superintendent and proposed crew leaders/foremen who are qualified and available to perform the work stated in this proposal:	Proposed Superintendent:	Certified and Trained: <input type="checkbox"/> Yes <input type="checkbox"/> No
	Crew leaders/foreman:	<input type="checkbox"/> Yes <input type="checkbox"/> No

b. Provide the number of **prime contractor crews** qualified and available to perform the work stated in this proposal:

c. The Contractor's superintendent (named above) shall have been responsible for or managed projects similar in size to this proposed project. Provide not less than **three (3)** references within the last **three (3)** years in the United States to document the proposed superintendent's ability and qualifications to meet this requirement. Each reference shall be from separate projects. Additional similar projects may be attached at the Contractor's discretion.

****The square footage (SF) in the following Superintendent's References DO NOT COUNT towards the Prime Contractors' total numbers above.****

1. Project Name:			
Location:			
Facility (MH, wet well, etc.):	Area (SF):		
Coating Manufacturer:	Name of Coating Applied:		
Start Date:	End Date:		
Cost:			
Client:			
Client Contact Name:			
Client Phone:			

Scope/Additional Information:

Cementitious base applied (Y/N)?

2. Project Name:			
------------------	--	--	--

LIFT STATION REHABILITATION CONTRACTOR QUALIFICATION FORM

*****MUST BE COMPLETED AND INCLUDED WITH BID*****

Fayetteville PWC reserves the right to request information from the contractor to complete its assessment of the contractor or subcontractors qualifications. Partially complete forms may be considered non-responsive based on the quantity and quality of information provided. Wholly incomplete forms will be considered non-responsive and will result in rejection of the bid.

Location:			
Facility (MH, wet well, etc.):		Area (SF):	
Coating Manufacturer:		Name of Coating Applied:	
Start Date:		End Date:	
Cost:			
Client:			
Client Contact Name:			
Client Phone:			
Scope/Additional Information:			
Cementitious base applied (Y/N)?			
3. Project Name:			
Location:			
Facility (MH, wet well, etc.):		Area (SF):	
Coating Manufacturer:		Name of Coating Applied:	
Start Date:		End Date:	
Cost:			
Client:			
Client Contact Name:			
Client Phone:			
Scope/Additional Information:			
Cementitious base applied (Y/N)?			
4. Project Name:			
Location:			
Facility (MH, wet well, etc.):		Area (SF):	
Coating Manufacturer:		Name of Coating Applied:	
Start Date:		End Date:	
Cost:			
Client:			
Client Contact Name:			
Client Phone:			
Scope/Additional Information:			

LIFT STATION REHABILITATION CONTRACTOR QUALIFICATION FORM

*****MUST BE COMPLETED AND INCLUDED WITH BID*****

Fayetteville PWC reserves the right to request information from the contractor to complete its assessment of the contractor or subcontractors qualifications. Partially complete forms may be considered non-responsive based on the quantity and quality of information provided. Wholly incomplete forms will be considered non-responsive and will result in rejection of the bid.

Cementitious base applied (Y/N)?

SEWER BYPASS SUBCONTRACTOR EXPERIENCE AND RESOURCES

***NOTE: The following information (Items 1 through 4) SHALL be completed by Prime Contractor if the sewer main bypass will be completed with its own forces.**

- a. The sewer bypass subcontractor shall be trained and certified to install, operate, and maintain the sewer bypass equipment with at least **five (5) years** of experience obtained over the last **five (5) years**. Provide not less than **four (4)** completed projects completed in the last **two (2) years**, where the projects were of similar size and scope to the Work described in these Contract Documents. At least **one (1)** of the completed projects must have been completed in the last **twelve (12) months**.
- b. The sewer bypass subcontractor shall include a minimum of one (1) project that was related to a lift station rehabilitation contract, that was similar in size, scope, cost, etc. in the last **three (3) years**.
- c. The sewer bypass subcontractor shall perform the bypass pumping operation utilizing its own equipment and labor forces. The bypass pumping superintendent shall be an employee of the bypass subcontractor. **SECOND TIER SUBCONTRACTORS WILL NOT BE ALLOWED.**

1. Project Name:			
Location:			
Superintendent:			
Pipe Size/Material:	Length:		
Start Date:	End Date:		
Client:			
Client Contact Name:	Client Phone:		
Completed with own equipment and labor forces:			<input type="checkbox"/> Yes <input type="checkbox"/> No
If "No" was checked above, provide name of the Contractor completing work:			
Scope/ Project Cost /Additional Information:			

Cementitious base applied (Y/N)?

2. Project Name:			
Location:			
Superintendent:			
Pipe Size/Material:	Length:		
Start Date:	End Date:		
Client:			

LIFT STATION REHABILITATION CONTRACTOR QUALIFICATION FORM

*****MUST BE COMPLETED AND INCLUDED WITH BID*****

Fayetteville PWC reserves the right to request information from the contractor to complete its assessment of the contractor or subcontractors qualifications. Partially complete forms may be considered non-responsive based on the quantity and quality of information provided. Wholly incomplete forms will be considered non-responsive and will result in rejection of the bid.

Client Contact Name:		Client Phone:	
Completed with own equipment and labor forces:			<input type="checkbox"/> Yes <input type="checkbox"/> No
If "No" was checked above, provide name of the Contractor completing work:			
Scope/ Project Cost /Additional Information:			
Cementitious base applied (Y/N)?			
3. Project Name:			
Location:			
Superintendent:			
Pipe Size/Material:		Length:	
Start Date:		End Date:	
Client:			
Client Contact Name:		Client Phone:	
Completed with own equipment and labor forces:			<input type="checkbox"/> Yes <input type="checkbox"/> No
If "No" was checked above, provide name of the Contractor completing work:			
Scope/ Project Cost /Additional Information:			
Cementitious base applied (Y/N)?			
4. Project Name:			
Location:			
Superintendent:			
Pipe Size/Material:		Length:	
Start Date:		End Date:	
Client:			
Client Contact Name:		Client Phone:	
Completed with own equipment and labor forces:			<input type="checkbox"/> Yes <input type="checkbox"/> No
If "No" was checked above, provide name of the Contractor completing work:			
Scope/ Project Cost /Additional Information:			

LIFT STATION REHABILITATION CONTRACTOR QUALIFICATION FORM

*****MUST BE COMPLETED AND INCLUDED WITH BID*****

Fayetteville PWC reserves the right to request information from the contractor to complete its assessment of the contractor or subcontractors qualifications. Partially complete forms may be considered non-responsive based on the quantity and quality of information provided. Wholly incomplete forms will be considered non-responsive and will result in rejection of the bid.

Cementitious base applied (Y/N)?

SEWER BYPASS SUPERINTENDENT EXPERIENCE AND RESOURCES

<p>a. Provide the names of the proposed superintendent and crew who are qualified and available to perform the work stated in this proposal:</p>	<p>Proposed Superintendent:</p>	<p>Certified and Trained: <input type="checkbox"/> Yes <input type="checkbox"/> No</p>
	<p>Crew:</p>	<p><input type="checkbox"/> Yes <input type="checkbox"/> No</p>

b. All sewer bypass pumping operations shall be performed under the constant direction of a superintendent employed by the sewer bypass subcontractor who shall remain on site and be in responsible charge throughout the bypass pumping operation. Provide not less than **three (3)** completed bypass pumping operations completed in the last **three (3) years**, where the projects were of similar size and scope to the Work described in these Contract Documents, and where the proposed bypass pumping superintendent – as listed above – acted in full capacity as superintendent for the bypass pumping subcontractor. The reference projects shall be sufficient to provide evidence of the Superintendent’s competency and qualifications. At least **one (1)** of the reference projects must have been completed in the last **twelve (12) months**.

1. Project:			
Start Date:		End Date:	
Pipe Size/Material:		Length:	
Client:			
Client Contact Name:		Client Phone:	
2. Project:			
Start Date:		End Date:	
Pipe Size/Material:		Length:	
Client:			
Client Contact Name:		Client Phone:	
3. Project:			
Start Date:		End Date:	
Pipe Size/Material:		Length:	
Client:			
Client Contact Name:		Client Phone:	
4. Project:			
Start Date:		End Date:	

LIFT STATION REHABILITATION CONTRACTOR QUALIFICATION FORM

*****MUST BE COMPLETED AND INCLUDED WITH BID*****

Fayetteville PWC reserves the right to request information from the contractor to complete its assessment of the contractor or subcontractors qualifications. Partially complete forms may be considered non-responsive based on the quantity and quality of information provided. Wholly incomplete forms will be considered non-responsive and will result in rejection of the bid.

Pipe Size/Material:		Length:	
Client:			
Client Contact Name:		Client Phone:	
5. Project:			
Start Date:		End Date:	
Pipe Size/Material:		Length:	
Client:			
Client Contact Name:		Client Phone:	
6. Project:			
Start Date:		End Date:	
Pipe Size/Material:		Length:	
Client:			
Client Contact Name:		Client Phone:	

ADDITIONAL ITEMS

The following items shall be submitted as attachments with the Bid:

- a. Certified Statement from the manufacturer that the Prime Contractor is a certified and/or licensed installer of the proposed lining system.
- b. Number of years of experience in performing this type of work:
- c. Number of years of experience installing the proposed lining system:
- d. Affidavit stating any OSHA violations occurring in the past three (3) years.
- e. A statement provided by the Surety Company stating the Bidder's bonding limit and a statement of the amount of work currently under bond.
- f. Most recent copy of company's annual W-3 showing wages paid.

The Owner may conduct such investigations/verifications as deemed necessary to establish the responsibility, qualification and financial ability of the Bidder. Should the Owner adjudge that the apparent low bidder is not the lowest responsive, responsible bidder by virtue of the above information furnished, said apparent low bidder will be so notified and his bid security shall be returned to him without prejudice. Failure or refusal to furnish any items of information requested by the Owner shall be considered as non-responsive and therefore basis for rejection of the bid.

Submitted By (print):

Date:

Title:

Company:

Signature:

LIST OF SUBCONTRACTORS

In compliance with the Instructions to Bidders and the Supplementary Conditions, the undersigned submits the following names of Subcontractors to be used in performing the Work.

The Bidder certifies that all Subcontractors listed are eligible to perform the Work and that all Subcontractors performing more than five percent of the work are listed.

<u>Subcontractor's Name</u>	<u>Subcontractor's Work</u>	<u>% of Work</u>
_____	_____	_____ %
_____	_____	_____ %
_____	_____	_____ %
_____	_____	_____ %
_____	_____	_____ %

Bidder's Signature

BID BOND

This is a Bid Bond that is subject to the provisions of Article 3 of Chapter 44A of the North Carolina General statutes.

This Bond is executed on _____, 20 ____ .

The name of the PRINCIPAL is _____ (1)

_____ (2)

The name of the SURETY is _____

Fayetteville Public Works Commission, Fayetteville, North Carolina is the OWNER

The amount of the Bond is _____

_____ (Dollars) (\$ _____)

KNOW BY ALL MEN BY THESE PRESENTS, the Principal and Surety above named are hereby held and firmly bound unto the above named OWNER hereinafter called the OWNER in the penal sum of the amount stated above in lawful money of the United States, for the payment of which, well and truly to be made, we hereby jointly and severally bind ourselves, our heirs, executors, administrators, successors and assigns.

The condition of the above obligation is such that whereas the Principal has submitted to the OWNER a certain Bid, attached hereto and hereby made a part hereof to enter into a Contract in writing, for the construction of:

LIFT STATION REHABILITATION

NOW, THEREFORE

- (a) If said Bid shall be rejected, or in the alternate,
- (b) If said Bid shall be accepted and the Principal shall execute and deliver a Contract in the Form of Contract attached hereto (properly completed in accordance with said Bid) and shall furnish a bond for his faithful performance of said Contract, and for the payment of all persons performing labor or furnishing materials in connection therewith, and shall in all other respects perform the agreement created by the acceptance of said Bid, then this obligation shall be void, otherwise the same shall remain in force and effect; it being expressly understood and agreed that the liability of the Surety for any and all claims hereunder shall, in no event, exceed the penal amount of this obligation as herein stated.

The Surety, for value received, hereby stipulates and agrees that the obligations of said Surety and its Bond shall be in no way impaired or affected by any extension of the time within which the Owner may accept such Bid; and said Surety does hereby waive notice of any such extension.

IN WITNESS WHEREOF, the Principal and the Surety have hereunto set their hands and seals, and such of them as are corporations have caused their corporate seals to be hereto affixed and these presents to be signed by their proper officers, the day and year first set forth above.

ATTEST:

(Principal Secretary)
(SEAL)

Principal

BY: _____ (3)

(Address)

Witness as to Principal

Surety

(Address)

(Address)

ATTEST:

N.C. Resident Agent
(SEAL)

Witness as to Surety

(Address)

- (1) Correct name of Contractor
- (2) A Corporation, a Partnership or an Individual, as the case may be
- (3) If Contractor is a Partnership, all partners should execute Bond

**POWER OF ATTORNEY
(Attach)**

**AFFIDAVIT OF ORGANIZATION AND AUTHORITY SWORN STATEMENT
LIFT STATION REHABILITATION**

STATE OF _____

COUNTY OF _____

_____ being the first duly sworn on oath deposes and says that the Bidder on the attached Bid Form is organized as indicated below and that all statements herein made are made on behalf of such Bidder and that this deponent is authorized to make them.

(Fill Out Applicable Paragraph)

1. CORPORATION

The bidder is a corporation organized and existing under the laws of the State of _____ and its President is _____, and its Secretary is _____, and does have a corporate seal. The _____ is authorized to sign construction Contract and Bids for the company by action of its Board of Directors taken _____, a certified copy of which is hereto attached. (Strike out last sentence if not applicable.)

2. PARTNERSHIP

The Bidder is a Partnership consisting of _____ and _____, partners doing business under the name of _____.

3. SOLE TRADER

The Bidder is an individual and if operating under a trade name, such trade name is as follows:

4. ADDRESS

The business address of the Bidder is as follows:

Its phone number is _____

Bidder

By: _____

EQUAL EMPLOYMENT OPPORTUNITY

During the performance of this Contract the Contractor agrees as follows:

- a. The Contractor will not discriminate against any employee or applicant because of race, color, religion, sex, or national origin. The Contractor will take affirmative action to ensure that applicants are employed, and that employees are treated during employment, without regard to race, color, religion, sex, or national origin. Such action shall include but not be limited to the following: employment, upgrading, demotion, or transfer, recruitment or recruitment advertising, layoff or termination, rates of pay or other forms of compensation, and selection for training, including apprenticeship. The Contractor agrees to post in conspicuous places, available to employees and applicants for employment, notices setting forth the provisions of the nondiscrimination clause.
- b. The Contractor will, in all solicitations or advertisements for employees placed by or on behalf of the Contractor, state that all qualified applicants will receive consideration for employment without regard to race, color, religion, sex, or national origin.
- c. The Contractor will send to each labor union or representative of workers with which he has a collective bargaining agreement or other Contract understanding, a notice, to be provided, advising the labor union or worker's representative of the Contractor's commitments under the Equal Employment Opportunity Section of this Contract, and shall post copies of the notice in conspicuous places available to employees and applicants for employment.
- d. In the event of the Contractor's noncompliance with the nondiscrimination clauses of this Contract or with any of such rules, regulations, or orders, this Contract may be canceled, terminated, or suspended in whole or in part and the Contractor may be declared ineligible for further OWNER Contracts.
- e. The Contractor will include the provisions of this section in every subcontract or purchase order unless exempted by rules, regulations, or orders of the OWNER so that such provisions will be binding upon each Subcontractor or vendor.

(Use the following form for signatures by a CORPORATION):

Corporate Name

ATTEST:

(Assistant) Secretary

(Vice) President

(CORPORATE SEAL)

(Use the following form for signatures by and INDIVIDUAL):

BY: _____ (Seal)

WITNESS:

(ACKNOWLEDGEMENT OF THE ABOVE SIGNATURE MUST BE NOTARIZED USING FORM ON FOLLOWING PAGE)

NONDISCRIMINATION CLAUSE

It is specifically agreed as part of the consideration of the signing of this Contract that the parties hereto, their agents, officials, employees or servants will not discriminate in any manner on the basis of age, handicap, race, color, creed, sexual orientation or national origin with reference to the subject matter of this Contract, no matter how remote.

This provision being incorporated for the benefit of Fayetteville Public Works Commission, Fayetteville, North Carolina and its residents may be enforced as set out in said ordinances, enforcement of this provision shall be by action for specific performance, injunctive relief, or other remedy as by law provided.

This provision shall be binding on the successors and assigns of the parties hereto with reference to the subject matter of this Contract.

(Use the following form for signatures by a CORPORATION):

Corporate Name

ATTEST:

(Assistant) Secretary

BY: _____
(Vice) President

(Printed Name)

BY: _____
(Printed Name)

(Corporate Seal)

(Use the following form for signatures by a PARTNERSHIP or INDIVIDUAL):

BY: _____(SEAL)

(Printed Name)

WITNESS:

(Printed Name)

NON-COLLUSIVE AFFIDAVIT

State of _____)
_____)

County of _____)

_____ being first duly sworn,
deposes and says that:

- (1) He is the _____
(Owner, Partner, Officer, Representative or Agent)
of _____ the BIDDER that has
submitted the attached BID;
- (2) He is fully informed respecting the preparation and contents of the attached BID and of all
pertinent circumstances respecting such BID;
- (3) Such BID is genuine and is not a collusive or sham BID;
- (4) Neither the said BIDDER nor any of its officers, partners, owners, agents, representatives,
employees or parties in interest, including this affiant, have in any way colluded, conspired,
connived or agreed, directly or indirectly, with any other BIDDER, firm, or person to submit
a collusive or sham BID in connection with the Contract for which the attached BID has
been submitted; or to refrain from bidding in connection with such Contract; or have in any
manner, directly or indirectly, sought by agreement or collusion, or communication, or
conference with any BIDDER, firm, or person to fix the price or prices in the attached BID
or of any other BIDDER, or to fix any overhead, profit, or cost elements of the BID price
or the BID price of any other BIDDER, or to secure through any collusion, conspiracy,
connivance, or unlawful agreement any advantage against (Recipient), or any person
interested in the proposed Contract;
- (5) The price or prices quoted in the attached BID are fair and proper and are not tainted by
any collusion, conspiracy, connivance, or unlawful agreement on the part of the BIDDER
or any other of its agents, representatives, owners, employees or parties in interest,
including this affidavit.

BY _____

ITS _____
(Title)

Subscribed and sworn to before me this _____ day of _____, 20 ____ .

Notary Public

My Commission Expires:

END OF AFFIDAVIT

F.T.A. CERTIFICATION REGARDING LOBBYING

Certification for Contracts, Grants, Loans, and Cooperative Agreements

(To be submitted with each bid or offer exceeding \$100,000)

The undersigned _____ certifies, to the best of his or her knowledge and belief, that:

- (1) No federal appropriated funds have been paid or will be paid, by or on behalf of the undersigned, to any person for influencing or attempting to influence an officer or employee of an agency, a member of Congress, an officer or employee of Congress, or an employee of a member of Congress in connection with the awarding of any federal contract, the making of any federal grant, the making of any federal loan, the entering into of any cooperative agreement, and the extension, continuation, renewal, amendment, or modification of any federal contract, grant, loan, or cooperative agreement.
- (2) If any funds other than federal appropriated funds have been paid or will be paid to any person for making lobbying contacts to an officer or employee of any agency, a member of Congress, an officer or employee of Congress, or an employee of a member of Congress in connection with this federal contract, grant, loan, or cooperative agreement, the undersigned shall complete and submit Standard Form--LLL, "Disclosure Form to Report Lobbying," in accordance with its instructions [as amended by "Government wide Guidance for New Restrictions on Lobbying," 61 Fed. Reg. 1413 (1/19/96). Note: Language in paragraph (2) herein has been modified in accordance with Section 10 of the Lobbying Disclosure Act of 1995 (P.L. 104-65, to be codified at 2 U.S.C. 1601, *et seq.*.)]
- (3) The undersigned shall require that the language of this certification be included in the award documents for all subawards at all tiers (including subcontracts, subgrants, and contracts under grants, loans, and cooperative agreements) and that all subrecipients shall certify and disclose accordingly.

This certification is a material representation of fact upon which reliance was placed when this transaction was made or entered into. Submission of this certification is a prerequisite for making or entering into this transaction imposed by 31, U.S.C. § 1352 (as amended by the Lobbying Disclosure Act of 1995). Any person who fails to file the required certification shall be subject to a civil penalty of not less than \$10,000 and not more than \$100,000 for each such failure.

[Note: Pursuant to 31 U.S.C. § 1352(c)(1)-(2)(A), any person who makes a prohibited expenditure or fails to file or amend a required certification or disclosure form shall be subject to a civil penalty of not less than \$10,000 and not more than \$100,000 for each such expenditure or failure.]

The Contractor, _____, certifies or affirms the truthfulness and accuracy of each statement of its certification and disclosure, if any. In addition, the Contractor understands and agrees that the provisions of 31 U.S.C. A 3801, *et seq.*, *apply* to this certification and disclosure, if any.

_____ Signature of Contractor's Authorized Official

_____ Name and Title of Contractor's Authorized Official

_____ Date

**CERTIFICATION OF PRIMARY PARTICIPANT REGARDING DEBARMENT,
SUSPENSION AND OTHER RESPONSIBILITY MATTERS**

The Primary Participant, _____ (major third party contractor), certifies to the best of its knowledge and belief, that it and its principals:

1. Are not presently debarred, suspended, proposed for debarment, declared ineligible, or voluntarily excluded from covered transactions by any Federal department or agency;
2. Have not within a three-year period preceding this proposal been convicted of or had a civil judgment rendered against them for commission of fraud or a criminal offense in connection with obtaining, attempting to obtain, or performing a public (Federal, State or local) transaction or contract under a public transaction; violation of Federal or State antitrust statutes or commission of embezzlement, theft, forgery, bribery, falsification or destruction of records, making false statements, or receiving stolen property;
3. Are not presently indicted for or otherwise criminally or civilly charged by a governmental entity (Federal, State or local) with commission of any of the offenses enumerated in paragraph (2) of this certification; and
4. Have not within a three-year period preceding this application/proposal had one or more public transactions (Federal, State or local) terminated for cause or default.

(If the primary participant is unable to certify to any of the statements in this certification, the participant shall attach an explanation to this certification.)

THE PRIMARY PARTICIPANT _____ CERTIFIES OR AFFIRMS THE TRUTHFULNESS AND ACCURACY OF THE CONTENTS OF THE STATEMENTS SUBMITTED ON OR WITH THIS CERTIFICATION AND UNDERSTANDS THAT THE PROVISIONS OF 31 U.S.C. SECTIONS 3801 ET. SEQ. ARE APPLICABLE THERETO.

Signature

Title

Printed Name

Date

***** THIS PAGE WAS INTENTIONALLY LEFT BLANK*****



**MINORITY, WOMEN, AND DISADVANTAGED
BUSINESS ENTERPRISE PROGRAM**

for

**Construction, A&E Services, Purchase Contracts,
Professional Services, and General Services**

Contents

PURPOSE	4
OVERVIEW	4
I. INTRODUCTION	5
II. ADMINISTRATION	5
III. DEFINITIONS	5
IV. PROCEDURES FOR CONSTRUCTION CONTRACTS	7
A. Purpose and Application	7
B. MWDBE Aspirational Goals	7
C. Invitation for Bids	7
D. PWC Responsibilities	8
E. Contractor Good-Faith Efforts	9
F. Awarding of Construction Contracts	11
G. Counting MWDBE Participation Toward Meeting the Aspirational Goals	12
H. Documentation of Attainment of MWDBE Participation Requirements	13
V. PROCEDURES FOR ARCHITECTURE & ENGINEERING (A&E) CONTRACTS	13
A. Purpose and Application	13
B. MWDBE Aspirational Goals	14
C. Request for Qualifications	14
D. PWC Responsibilities	14
E. Meeting MWDBE Aspirational Goals	15
F. Counting MWDBE Participation	15
G. Provider Good-Faith Efforts	15
H. Documenting Good-Faith Efforts	16
VI. PROCEDURES FOR PURCHASE CONTRACTS	17
A. Purpose and Application	17
B. MWDBE Aspirational Goals	17
C. Request for Quotes or Invitation for Bids	17
D. PWC Responsibilities	18
E. Award of Purchase Contracts	19
VII. PROCEDURES FOR PROFESSIONAL, GENERAL (OTHER) SERVICE CONTRACTS	19
A. Purpose and Application	20
B. MWDBE Aspirational Goals	20
C. PWC's Responsibilities	20
D. Request for Proposals	21
E. Meeting MWDBE Aspirational Goals	21
F. Counting MWDBE Participation	21

G. Provider Good-Faith Efforts	22
I. Documenting Good-Faith Efforts	23
VIII. UTILIZATION OF JOINT VENTURE	23
IX. MWDBE REPORTING PROCEDURE	24
MWDBE COMPLIANCE PROVISIONS	25
Affidavit A: Listing of the Good Faith Efforts	27
Affidavit B: Intent to Perform Contract with Own Workforce	28
Affidavit C: Percentage of MWDBE Participation	29
Affidavit D: Good Faith Efforts	31
Affidavit E: Identification of MWDBE/Local Participation	32
MWDBE ADD / CHANGE FORM	33

PURPOSE

The Fayetteville Public Works Commission (PWC) is committed to promoting the utilization of Minorities, Women, and Disadvantaged Businesses by providing equal opportunity for participating in all aspects of PWC's contracting and procurement programs, including but not limited to, construction projects, A&E services, purchase contracts, and professional and general (other) service contracts.

To achieve this purpose, PWC has established this Minority, Women, and Disadvantaged Business Enterprise Program (MWDBE) to support historically underutilized businesses, encourage capacity development, and offer procurement opportunities to certified business enterprises.

OVERVIEW

PWC's MWDBE Program is a voluntary goals program in construction, A&E services, purchase contracts, and professional and general (other) services based on "good-faith efforts." These goals are established for a five-year period and achievement will be evaluated annually.

The aspirational goals of PWC for the utilization of Minority, Women, and Disadvantaged Business Enterprises are:

Minority business participation in construction services	14%
Women business participation in construction services	11%
Minority business participation in A&E services	6%
Women business participation in A&E services	5%
Minority business participation in purchase contracts	4%
Women business participation in purchase contracts	4%
Minority business participation in professional services	19%
Women business participation in professional services	3%
Minority business participation in general (other) services	9%
Women business participation in general (other) services	4%

I. INTRODUCTION

In 2021, Fayetteville Public Works Commission (PWC) contracted with Griffin & Strong, P.C. (GSPC) to conduct a Disparity Study to determine the effectiveness of the current policies related to local, minority, and women owned businesses and to recommend modifications and adjustments, if necessary, to PWC's policies that comply with the law.

PWC continues to implement race and gender conscious and race and gender-neutral measures to try to increase utilization of Minority, Women, and Disadvantaged Business Enterprise (MWDBE) firms. PWC has a basis to continue race and gender conscious remedies or policies toward achieving annual aspirational goals.

The MWDBE aspirational goals and guidelines developed and recommended do not require nor provide for racially based set-asides; rather they require good-faith effort by both local government and contractors to recruit and select minorities and women businesses, consistent with North Carolina Statutes and the Constitution of the United States as interpreted by the Croson Decision.

II. ADMINISTRATION

PWC General Manager/CEO is authorized to take all usual and legal administrative actions necessary to implement this Program. The ultimate responsibility for the MWDBE Program administration is assigned to the PWC General Manager/CEO or its designee. PWC General Manager/CEO or its designee is either to be personally responsible or to designate a specific person to coordinate and manage this Program. PWC General Manager/CEO or its designee is responsible for determining whether a contractor has complied with this Program and shown good-faith efforts to do so. Except for those staff services specifically assigned by this Program to other departments, the heads of departments responsible for the construction, and procurement of services and goods shall be responsible to PWC General Manager/CEO or its designee and shall cooperate with PWC General Manager/CEO or its designee in implementing this Program.

The MWDBE Program shall apply to all construction contracts, A&E contracts, purchase contracts, and services as specified in Sections IV through VII. The provisions of this Program take precedence over any other department plans or procedures in conflict herewith, except specific requirements mandated by terms or conditions of agreements in force between PWC and the federal government or the State of North Carolina that require different procedures than those described in this Program. This Program will be evaluated at the end of five years to determine its effectiveness and what adjustments are required.

III. DEFINITIONS

Affirmative Action - Specific steps to eliminate discrimination and efforts to ensure nondiscriminatory results and practices in the future, and to fully involve Minority, Women, and Disadvantaged Business Enterprises in contracts and programs.

Aspirational Goal/Goal - A voluntary percentage or quantitative objective.

Bidder/Participant - Any person, firm, partnership, corporation, association, or joint venture seeking to be awarded a public contract or subcontract.

Contract - A mutually binding legal relationship or any modification thereof obligating the seller to furnish equipment or service, including construction and leases, and obligating the buyer to pay for them.

Contractor - Any person, firm, partnership, corporation, association, or joint venture that has been awarded a public contract or lease, including every subcontract on such a contract.

Day – A calendar day of 24 hours measured from midnight to the next midnight. Also referred to throughout the Program documents as “days or “calendar days.”

Discrimination - To distinguish, differentiate, separate and/or segregate on the basis of age, race, religion, color, sex, national origin, handicap and/or veteran status.

Equipment - Includes materials, supplies, commodities, and apparatus.

Joint Venture - An association of two or more businesses to carry out a single business enterprise for profit, for which purpose they combine their property, capital, efforts, skills, and knowledge.

Lessee - A business that leases, or is negotiating to lease, property from PWC or equipment or services to PWC, or to the public on PWC property.

Minority - A person who is a citizen or lawful permanent resident of the United States and who is:

- a. Black American (a person having origins in any of the black racial groups of Africa);
- b. Hispanic American (a person of Mexican, Puerto Rican, Cuban, Central or South American, or other Spanish culture or origin, regardless of race);
- c. Portuguese (a person of Portuguese, Brazilian, or other Portuguese culture origin, regardless of race);
- d. Asian American (a person having origins in any of the original people of the Far East, Southeast Asia, the Indian sub-continent, or the Pacific Islands); and
- e. Native American (a person having origins in any of the original people of North America).

MWDBE - Any certified minority, women, and disadvantaged business enterprise.

Minority, Women, Disadvantaged Business Enterprise (MWDBE) - A business that is at least fifty-one (51) percent owned and controlled by minority group members or women. An MWDBE is **bona fide** only if the minority group or female ownership interests are real and continuing and not created solely to meet the MWDBE requirement. In addition, the MWDBE must itself perform satisfactory work or services or provide supplies under the contract and not act as a mere conduit. In short, the contractual

relationship must also be **bona fide**.

IV. PROCEDURES FOR CONSTRUCTION CONTRACTS

A. Purpose and Application

1. The general purpose of this Program is to help develop and support Minority, Women, and Disadvantaged Business Enterprises (MBE, WBE, and DBE) by providing opportunities for participation in the performance of all construction contracts financed entirely with PWC funds.
2. This Program shall apply to construction contracts when the PWC's estimated contract cost is \$100,000 or more, except when a contract is exempt from competitive bidding under the General Statutes of North Carolina. Contracts between \$30,000 and \$99,999.99 will also be covered by the exemption.
3. Where contracts are financed in whole or in part with federal or state funds, including grants, loans, or other funding sources containing MBE, WBE, DBE Programs, PWC will follow the federal government or the State of North Carolina. PWC General Manager/CEO or its designee will be responsible for monitoring the Program to ensure the goals are met.
4. Since PWC construction contracts are prepared by the Engineering and Facilities Departments, each of these departments shall prepare such documents with Procurement pre-approved templates for the bidding process, which includes the Program goals as required to implement this Program.
 - a. Within sixty (60) days of the Commission's approval of this Program, the departmental procedures and contract provisions shall be in effect for all bid documents issued after the date of Commission approval.

B. MWDBE Aspirational Goals

1. To implement the purpose of this Program, the goal shall be to award at least fourteen (14) percent of the total of all construction contract award amounts in each fiscal year to MBE firms and at least eleven (11) percent to WBE firms.
2. PWC General Manager/CEO or its designee may determine that higher or lower goals are appropriate on a project-by-project basis, where it can be shown that the type, size, or location of the project will affect the availability of MBE, WBE, or DBE firms, so long as the aggregate of all contracts does not lower the annual goals.

C. Invitation for Bids

1. Bidders shall submit MWDBE information with their bids. Such information shall be subject to verification by MWDBE Program staff before awarding the contract. The information shall include the names of the MWDBEs to be used and the dollar value of each such MWDBE transaction.

2. Contractors, subcontractors, suppliers, or MWDBE members of a joint venture intended to satisfy the PWC's MBE/WBE/DBE goals shall be certified by the State Department of Transportation (DOT) or North Carolina Office of Historically Underutilized Business (HUB).

D. PWC Responsibilities

1. **MWDBE Directory** – The MWDBE Program staff will establish and maintain a directory of certified Minority, Women, and Disadvantaged Business Enterprises. The purpose of the directory is to provide a resource for prime bidders on PWC construction projects who intend to solicit bids from MBE and WBE subcontractors and suppliers to meet PWC's MBE and WBE goals. The directory will not constitute a recommendation or endorsement of any listed firm.

The directory will be developed and maintained by the MWDBE Program Staff.

- a. The directory will include:
 - i. Business name, address, telephone number, and email address;
 - ii. Name(s) of business owner(s);
 - iii. Type of license;
 - iv. NAICS;
 - v. Type of MWDBE certification, and;
 - vi. Certification and expiration date with an acceptable agency.
 - b. PWC shall advertise on a contract-by-contract basis throughout the year as deemed necessary for MWDBE outreach. Advertisements shall be placed with minority/women-focused publications (state and local). Notification will also be sent to community organizations which might have knowledge of MWDBE firms.
 - c. The department heads and MWDBE Program staff should attend local and regional business fairs to promote the MWDBE Program. The departments shall also identify potentially eligible contractors through affirmative action efforts and the normal course of business. The names of identified contractors shall be forwarded to the MWDBE Program staff.
2. **MWDBE Eligibility Standards** – The eligibility of a business is determined by the ownership and control of the business.
 - a. An eligible Minority Business Enterprise owner is a citizen or lawful permanent resident of the United States, a member of a recognized ethnic or racial group, and fifty-one (51) percent owner of the business.
 - b. The eligible ethnic or racial groups are:
 - i. Black/African American
 - ii. Hispanic American
 - iii. Asian American

iv. Native American

- c. An eligible Women Business Enterprise owner is a citizen or lawful resident of the United States and a fifty-one (51) percent owner of the business and is female.

3. **Removal of MWDBE Procedures** - A contractor certified as a MWDBE may be removed from the program directory for, but not limited to, any of the following reasons:

- a. **Change of Status** - PWC General Manager/CEO or its designee may remove a MWDBE if he/she finds that the ownership or control of the business changes so that the business no longer meets the requirements of Section IV, D(2) (b) and (c) above.
- b. **Failure to comply with the MWDBE Program** - The certification of a business as a MWDBE may be removed by PWC General Manager/CEO or its designee if he/she finds any of the following conditions:
- i. That a business has submitted inaccurate, false or incomplete information to PWC;
 - ii. That in performance of a contract, a business has failed to comply with requirements of the contract with PWC;
 - iii. That in performance of a contract, a business has failed to comply with MWDBE requirements of a contract established by a contractor with PWC in response to PWC requirements; or
 - iv. That a business has otherwise failed to comply with the provisions of this MWDBE Program.
- c. **Appeal of Removal** - A business may appeal a determination of a MWDBE by satisfying the eligibility requirements in Section IV, D (2) (b) and (c).
- d. **Pre-bid Meeting or Site Visit** - PWC may hold a pre-bid meeting on formal and informal bid contracts for all prospective bidders, subcontractors, and MWDBEs for the purpose of explaining the provisions of the MWDBE Program, the process for bidding, and the contract to be performed. Available data on MWDBEs interested and/or capable of engaging in the prospective contract shall be made available to prospective bidders, contractors, and subcontractors.

E. Contractor Good-Faith Efforts

The contractor (bidder) shall make good-faith efforts to encourage the participation of MWDBEs in projects prior to submission of bids in order to be considered as a responsive bidder. A good-faith effort shall include, at a minimum, specific affirmative action steps and complete documentation thereof. The following list of factors to determine good-faith effort is not exclusive or exhaustive:

1. Whether the bidder attended any pre-submittal or pre-bid meetings, if scheduled

by PWC;

2. Whether the bidder identified and selected specific items of the project for which the contract could be performed by Minority and/or Women Business Enterprises, to provide an opportunity for participation by those enterprises (including, where appropriate, breaking down contracts into economically feasible units to facilitate MWDBE participation);
3. Whether the bidder advertised, a reasonable time before the date the bids are opened, in one or more daily or minority weekly newspapers or trade associations (i.e., N.C. Minority Business Association), trade journals, or other media;
4. Whether the bidder provided email notice of their interest in bidding on the contract to at least three (3) Minority, Women, or Disadvantaged Business Enterprises (for each identified sub-item of the contract) licensed to provide the specific items of the project a reasonable time prior to the opening of bids;
5. Whether the bidder provided interested Minority, Women, and Disadvantaged Business Enterprises with information about the Plan, specifications, and requirements for the selected subcontracting or material supply work;
6. Whether the bidder contacted PWC's MWDBE Program staff for assistance in identifying minority and women businesses certified with approved public agencies as referenced in Section IV, D (2) (b) and (c);
7. Whether the bidder negotiated in good-faith with Minority, Women, or Disadvantaged Business Enterprises and did not unjustifiably reject as unsatisfactory bids prepared by a Minority, Women, or Disadvantaged Business Enterprises, as defined by PWC;
8. Whether the bidder, where applicable, advised and made efforts to assist interested MWDBEs in obtaining bonds, lines of credit, or insurance required by PWC or contractor;
9. Whether the bidder's efforts to obtain MWDBEs participation could reasonably be expected by PWC to produce a level of participation sufficient to meet the goals of PWC.

Bidders are cautioned that even though their submittal indicates they will meet the MWDBE goals, they should document their good- faith efforts and be prepared to submit this information to protect their eligibility for award of the contract in the event PWC questions whether the good-faith requirement has been met.

10. **Performance of MBE/WBE/DBE Subcontractors and Suppliers** - The MWDBEs listed by the contractor on the Program Affidavits, which is determined by PWC to be certified, shall perform the work and supply the materials for which they are listed unless the contractor has received prior written authorization from PWC to perform the work with other forces or to obtain the materials from other sources.

The contractor shall enter into subcontracts and supply copies of all fully executed subcontracts with each MWDBE listed on the Program Affidavits to PWC's MWDBE Program staff after award of the contract and prior to the issuance of a Notice to Proceed. Any amendments to the subcontracts shall be submitted to the MWDBE Program staff within **five (5) days** of execution.

Authorization to utilize other forces or sources of materials shall be requested by submitting a "Change or Add a Subcontractor Form" for the following reasons:

- a. The listed MWDBE, after having had a reasonable opportunity to do so, fails or refuses to execute a written contract, when such written contract, based upon the general terms, conditions, plans and specifications for the project, or on the terms of such subcontractor's or supplier's written bid, is presented by the contractor.
- b. The listed MWDBE becomes bankrupt or insolvent.
- c. The listed MWDBE fails or refuses to perform his/her subcontract or furnish the listed materials.
- d. The work performed by the listed subcontractor is unsatisfactory according to industry standards and is not in accordance with the plans and specifications; or the subcontractor is substantially delaying or disrupting the progress of the work.

All "Change or Add a Subcontractor Forms" shall be accompanied by good faith efforts documentation as specified on the form.

F. Awarding of Construction Contracts

1. If a construction contract is to be awarded, it shall be awarded in accordance with North Carolina General Statutes to the lowest responsible bidder who complies with all of the prescribed requirements and either:
 - a. Made a good-faith effort to comply with these goals and requirements before the time bids are opened as described above. Where a good-faith effort is claimed by the apparent lowest responsible bidder, the bidder shall be required to submit documentation **WITHIN TWENTY-FOUR (24) HOURS OF PWC'S NOTIFICATION**, which in most instances will occur the day of bid opening to show that the criteria for good-faith efforts have been met, or
 - b. Once a firm is determined to be an eligible MWDBE, and before the contract is awarded, the total dollar value to be paid to the MWDBE shall be evaluated by the MWDBE Program Staff to ensure that it is in accordance with the bidder's proposal.

If the evaluation shows that the bidder has misrepresented MWDBE participation or has not made a good-faith effort to meet the contract goals for MBE or WBE

participation, the bidder may be disqualified.

G. Counting MWDBE Participation Toward Meeting the Aspirational Goals

The degree of participation by MWDBE contractors, subcontractors, suppliers, or joint-venture partners in contract awards shall be counted in the following manner:

1. Once a firm is determined to be an eligible MWDBE contractor in accordance with this Program, the total dollar value of the contract awarded to the MWDBE is counted as participation.
2. The goals can be met by any certified MWDBE contractor, subcontractor, supplier, trucker, or joint-venture partner as listed in PWC and agency directory. All MWDBEs used to meet the goal must be certified by an approved agency and verified by PWC at the time of bid opening. Only certified firms can be counted toward the goal. The standard for certification is set forth in this Program.
3. The total dollar value of a contract with a disadvantaged business owned and controlled by a minority woman is counted toward either the minority goal or the goal for women, but not toward both. The contractor or MWDBE Program staff may choose the goal to which the value is applied.
4. In the case of a joint venture, the joint venture recipient or contractor may count toward its MWDBE goals a portion of the total dollar value of the contract that the MWDBE partner's participation in the joint-venture represents. Credit will be given equal to the minority partner's percentage of ownership in the joint venture. A MWDBE joint-venture partner must be responsible for a clearly defined portion of the work to be performed in addition to satisfying requirements for ownership and control.
5. A recipient or contractor may count toward its MWDBE goals only expenditures to MWDBEs whose ownership interests are real and continuing and not created solely to meet PWC's goals for participation, and that perform a commercially useful function in the work of a contract. A MWDBE is considered to perform a commercially useful function when it is responsible for execution of a distinct element of the work of a contract and carries out its responsibilities by actually performing, managing, and supervising the work involved. To determine whether a MWDBE is performing a commercially useful function, the MWDBE Program staff shall evaluate the amount of work subcontracted, industry practices, and other relevant factors. Consistent with normal industry practices, an MWDBE may enter into subcontracts. If a MWDBE contractor subcontracts a significantly greater portion of the work of the contract than would be expected on the basis of normal industry practices, the MWDBE shall be presumed not to be performing a commercially useful function. Evidence to rebut this presumption may be presented to the MWDBE Program staff. The MWDBE may present evidence to rebut this presumption. The MWDBE Program staff decision on the rebuttal of this presumption is subject to review by PWC General Manager/CEO or its designee. Once a contractor is determined to be an eligible MWDBE in accordance with this section, the total dollar value of the contract awarded to MWDBE is counted toward the applicable MWDBE goals, except as provided in

the provisions of this section.

6. A contractor may count toward its MWDBE goals expenditures for materials and supplies obtained from MWDBE suppliers and manufacturers, provided that the MWDBE assumes the actual and contractual responsibility for the provision of the materials and supplies.

H. Documentation of Attainment of MWDBE Participation Requirements

In order that PWC General Manager/CEO or its designee may make a recommendation to PWC as to the responsiveness of bidders, bidders shall be required to submit the following information on each MWDBE-related subcontract:

1. A description of the subcontract and purchase(s) of significant equipment and supplies to be used to perform the subcontract or prime contract, including the name and address of each MWDBE firm selected, and the name and telephone number of a contact person;
2. The dollar amount of participation of each MWDBE;
3. A statement of intent from the MWDBE subcontractor or material supplier as;
 - a. Identified in Section IV, H(1) above that they intend to contract or supply the materials, or
 - b. Sworn statements, with appropriate documentation, showing that the contractor made a good-faith effort to comply with the MWDBE Program in accordance with Section IV, E of this Program.

V. PROCEDURES FOR ARCHITECTURE & ENGINEERING (A&E) CONTRACTS

A. Purpose and Application

1. The general purpose (goal) of this Program is to help develop and support MWDBEs by providing opportunities for participation in the performance of PWC's A&E contracts financed entirely with PWC funds.
2. This Program applies to all A&E contracts except contracts in those unique circumstances where written exemption of particular contracts is determined as an exception, and less than fifty thousand dollars (\$50,000.00) by PWC General Manager/CEO. PWC General Manager/CEO or its designee will be responsible for administering and monitoring the Program to ensure that appropriate action(s) are taken in efforts of achieving the goals.
3. Where contracts are funded in whole or in part with federal or state funds and the grants, loans, or other funding sources containing MWDBE Program requirements, PWC General Manager/CEO or its designee will be responsible for monitoring the Program to ensure the goals are met.

4. Since PWC Request for Qualifications (RFQ) are prepared by the Engineering and Facilities Departments, each of these departments shall prepare such documents with Procurement pre-approved templates for the qualification-based selection process, which includes the Program goals as required to implement this Program.

B. MWDBE Aspirational Goals

1. To implement this Program, the goal shall be to award six percent (6%) of the total A&E contract dollars awarded in each fiscal year to MBE firms and five percent (5%) to WBE firms. The goals will become effective on the date that PWC approves the Program and continue for a period of five (5) years.

C. Request for Qualifications

1. It is not required that contracts under \$50,000 meet the contract goal. When possible, at least twenty-five (25) percent of the firms notified of the contract opportunity shall be MWDBE. A list of available firms will be provided by the MWDBE Program staff to the Procurement Advisor and Department. The MWDBE Program staff shall track and report the firms that are notified and that provide submittals.

D. PWC Responsibilities

1. Identification of MWDBE Firms

- a. The MWDBE Program staff will establish and maintain a directory of certified Minority, Women, and Disadvantaged Business Enterprises. The purpose of the directory is to provide a resource on PWC A&E projects. The directory will not constitute a recommendation or endorsement of any listed firm. The directory will be developed and maintained by the MWDBE Program Staff.
- b. The directory will include:
 - i. Business name, address, telephone number, and email address;
 - ii. Name(s) of business owner(s);
 - iii. Type of license;
 - iv. NAICS;
 - v. Type of MWDBE certification, and;
 - vi. Certification and expiration date with an acceptable agency.
- c. PWC shall advertise on a contract-by-contract basis throughout the year as deemed necessary for MWDBE outreach. Advertisements shall be placed with minority/women-focused publications (state and local). Notification will also be sent to community organizations which might have knowledge of MWDBE firms.

- d. The department heads and MWDBE Program staff should attend local and regional business fairs to promote the MWDBE Program. The departments shall also identify potentially eligible firms through affirmative action efforts and the normal course of business. The names of identified firms shall be forwarded to the MWDBE Program staff.

E. Meeting MWDBE Aspirational Goals

1. Goals must be met by awarding contracts to certified MWDBE firms. The MWDBE must be certified at the time of the contract award. MWDBE firms not certified at the time of the contract award will not be counted towards MWDBE goals. MWDBE goals may be met by a certified joint venture or partnership. In the case of joint ventures or partnerships, MWDBE participation counted toward the goal will be equal to the percentage of the total dollar value of the contract that the MWDBE partner is responsible for performing.

F. Counting MWDBE Participation

1. The total dollar value of a contract with a disadvantaged business owned and controlled by a minority woman is counted toward either the minority goal or the goal for women, but not toward both. The contractor or MWDBE Program staff may choose the goal to which the value is applied.
2. If a determination is made by the MWDBE Program staff that the goals have not been met, the prime service provider will be required to submit a good-faith effort statement prior to PWC awarding the contract.

G. Provider Good-Faith Efforts

The following is a list of the efforts that should be made by the prime A&E firm to encourage MWDBE participation. In order to receive credit for having made "good faith efforts", the prime A&E firm should document all actions taken to include the following:

1. Attending pre-bid meetings scheduled by the department;
2. Identifying selected specific items of the project which could be executed by a MWDBE;
3. Soliciting MWDBE A&E firm participation in a reasonable time before the solicitations are due through advertisements in circulation media, trade publications, and minority-focused media;
4. Contacting local firms, firms owned by minorities or women, and associations or business development centers which disseminate information to local businesses and businesses owned by minorities or women in a timely manner to allow sufficient time for MWDBEs to respond;
5. Following up on initial solicitations of interest by contacting the MWDBE to determine whether the MWDBE was interested in performing specific items of the

project;

6. Attempting to enter into joint venture or partnership arrangements with MWDBEs and provide interested MWDBEs with information about the requirements for the project;
7. Providing assistance to MWDBEs in the review of qualification submittal and work to be done by sub-A&E firms;
8. Using available directories of certified MWDBEs and other available resources;
9. Ensuring that the firm negotiated in good faith with the MWDBE and did not unjustifiably reject as unsatisfactory qualifications prepared by any Minority, Women, or Disadvantaged Business Enterprise;
10. Making every effort to obtain Minority, Women, or Disadvantaged Business Enterprise participation that could reasonably be expected to produce a level of participation sufficient to meet the goals of PWC; and
11. Providing interested minority, women, and disadvantaged businesses with information relative to project requirements.

H. Documenting Good-Faith Efforts

If the prime A&E firm does not meet the goals for MWDBE participation at the time of qualification submittal, then the following documents indicating "good-faith efforts" should be submitted as a minimum:

1. A report of all proposals received by the prime service provider from MWDBE sub-A&E firms must indicate the action taken by the prime A&E firm in response to the qualification submittal. In cases where proposals have been rejected, the reason for rejection must be indicated.
2. Documentation of efforts to enter into agreements with MWDBEs for sub-A&E work or arrangements for joint ventures, partnerships, or other multi-entity relationships. Also included should be a statement of why agreements or arrangements were not made.
3. Proof of contact with MWDBEs and associations or business development centers that disseminate information to MWDBEs.
4. A copy of emails or notices sent to groups in Section VI, J(3) above notifying them of the firm's intent to submit a qualification submittal to PWC. The emails or notices should indicate the areas of work available for sub-A&E firms.
5. Description of assistance provided to MWDBEs in review of the qualification submittal and work to be done by sub-A&E firms.
6. Description of the use made by firms of available resources such as directories of MWDBEs.

7. Documentation of advertisements sent to general circulation media, trade publications, and minority-focused media.
8. Proof of attendance at any pre-bid meeting.

If the prime A&E firm fails to meet the MWDBE goals with its proposed project team and cannot provide documentation of "good-faith efforts", these failures will be noted to the involved department by the MWDBE Program Staff, and the firm may be disqualified.

VI. PROCEDURES FOR PURCHASE CONTRACTS

A. Purpose and Application

1. The general purpose of this Program is to help develop and support Minority, Women, and Disadvantaged Business Enterprises (MBE, WBE, and DBE) by providing opportunities for participation in purchase contracts financed entirely with PWC funds.
2. This Program shall apply to purchase contracts over \$30,000 for apparatus, materials, supplies and purchase contracts for goods where the patent-holder is not the sole supplier. PWC General Manager/CEO or its designee will be responsible for monitoring the Program to ensure the goals are met.
3. Where contracts are funded in whole or in part with federal or state funds and the grants, loans, or other funding sources containing MWDBE Program requirements, PWC General Manager/CEO or its designee will be responsible for monitoring the Program to ensure the goals are met.
4. Since PWC purchase contracts are prepared by various departments, each of these departments shall prepare such documents with Procurement pre-approved templates for the quote or bid process, which includes the goals as required to implement this Program. PWC Departments shall document and provide to the MWDBE Program staff a list of all providers notified and responses received for informal purchases.

B. MWDBE Aspirational Goals

1. To implement the purpose of this Program, the goal shall be to award at least four (4) percent of the total of all purchase contract award amounts in each fiscal year to MBEs and at least four (4) percent to WBE firms. It is further the intent of PWC to encourage, to the extent allowed the use of local vendors (defined as located within Cumberland, Hoke, or Harnett County) whenever doing so is consistent with the requirements under G.S. 143-129.

C. Request for Quotes or Invitation for Bids

1. The various departments soliciting goods will be responsible for contacting from the directory at least one MBE and one WBE for a price quotation of \$30,000 or more on each purchase contract with MWDBE availability.

2. A list of available MWDBEs will be provided by the MWDBE Program staff to the Procurement Advisor and Department. The MWDBE Program staff shall track and report the MWDBEs that are notified and that provide submittals.

D. PWC Responsibilities

1. Identification of MWDBEs

- a. The MWDBE Program staff will establish and maintain a directory of certified Minority, Women, and Disadvantaged Business Enterprises. The purpose of the directory is to provide a resource for on PWC purchase contracts. The directory will not constitute a recommendation or endorsement of any listed supplier. The directory will be developed and maintained by the MWDBE Program Staff.
 - b. The directory will include:
 - i. Business name, address, telephone number, and email address;
 - ii. Name(s) of business owner(s);
 - iii. NAICS;
 - iv. Type of MWDBE certification, and;
 - v. Certification and expiration date with an acceptable agency.
 - c. PWC shall advertise on a contract-by-contract basis throughout the year as deemed necessary for MWDBE outreach. Advertisements shall be placed with minority/women-focused publications (state and local). Notification will also be sent to community organizations which might have knowledge of MWDBE suppliers.
 - d. The department heads and MWDBE Program staff should attend local and regional business fairs to promote the MWDBE Program. The departments shall also identify potentially eligible suppliers through affirmative action efforts and the normal course of business. The names of identified suppliers shall be forwarded to the MWDBE Program staff.
2. **MWDBE Eligibility Standards** – The eligibility of a business is determined by the ownership and control of the business.
- a. An eligible Minority Business Enterprise owner is a citizen or lawful permanent resident of the United States, a member of a recognized ethnic or racial group, and fifty-one (51) percent owner of the business.
 - b. The eligible ethnic or racial groups are:
 - i. Black/African American
 - ii. Hispanic American
 - iii. Asian American
 - iv. Native American

- c. An eligible Women Business Enterprise owner is a citizen or lawful resident of the United States and a fifty-one (51) percent owner of the business and is female.
- 3. **Removal of MWDBE Procedures** - A supplier certified as a MWDBE may be removed from the program directory for, but not limited to, any of the following reasons:
 - a. **Change of Status** - PWC General Manager/CEO or its designee may remove a MWDBE if he/she finds that the ownership or control of the business changes so that the business no longer meets the requirements of Section IV, D(2) (b) and (c) above.
 - b. **Failure to comply with the MWDBE Program** - The certification of a business as a MWDBE may be removed by PWC General Manager/CEO or its designee if he/she finds any of the following conditions:
 - i. That a business has submitted inaccurate, false or incomplete information to PWC;
 - ii. That in performance of a contract, a business has failed to comply with requirements of the contract with PWC;
 - iii. That in performance of a contract, a business has failed to comply with MWDBE requirements of a contract established by a contractor with PWC in response to PWC requirements; or
 - iv. That a business has otherwise failed to comply with the provisions of this MWDBE Program.
 - c. **Appeal of Removal** - A business may appeal a determination of a MWDBE by satisfying the eligibility requirements in Section IV, D (2) (b) and (c).
 - d. **Pre-bid Meeting or Site Visit** - PWC may hold a pre-bid meeting on formal and informal bid contracts for all prospective bidders, subcontractors, and MWDBEs for the purpose of explaining the provisions of the MWDBE Program, the process for bidding, and the contract to be performed. Available data on MWDBEs interested and/or capable of engaging in the prospective contract shall be made available to prospective bidders, contractors, and subcontractors.

E. Award of Purchase Contracts

- 1. If a purchase contract is to be awarded, it shall be awarded in accordance with North Carolina General Statutes and/or other applicable PWC, Commission, and State regulations.

VII. PROCEDURES FOR PROFESSIONAL, GENERAL (OTHER) SERVICE CONTRACTS

A. Purpose and Application

1. The general purpose (goal) of this Program is to help develop and support MWDBEs by providing opportunities for participation in the performance of PWC's professional service contracts and general (other) service contracts (hereinafter referred to as service contracts).
2. This Program applies to all service contracts except contracts under \$30,000, and in those unique circumstances where PWC General Manager/CEO or its designee determines that an exception is necessary.
3. Where contracts are funded in whole or in part with federal or state funds and the grants, loans, or other funding sources containing MWDBE Program requirements, PWC General Manager/CEO or its designee will be responsible for monitoring the Program to ensure the goals are met.
4. PWC General Manager/CEO or its designee will be responsible for administering and monitoring the Program to ensure that appropriate action(s) are taken in efforts of achieving the goals.

B. MWDBE Aspirational Goals

1. To implement this Program, the goal shall be to award nine percent (9%) of the total service contract dollars awarded in each fiscal year to MBE firms and four percent (4%) to WBE firms. The goals will become effective on the date that PWC approves the Program and continue for a period of five (5) years.

C. PWC's Responsibilities

1. Identification of MWDBE Firms

- a. The MWDBE Program staff shall establish and maintain a directory of certified MWDBE service providers that shall be made available to all departments to assist them in identifying appropriate MWDBE service providers that can be used to meet PWC's MWDBE goals. The directory shall include the businesses which provide the services routinely procured by PWC and the NAICS which the businesses are capable of providing. The directory will not constitute a recommendation or endorsement of any listed business. The directory will include:
 - i. Business name, address, and telephone number;
 - ii. Name(s) of business owner(s);
 - iii. NAICS of services available;
 - iv. Type of MWDBE certification, and;
 - v. Certification and expiration date with an acceptable agency.
- b. PWC shall provide a list of opportunities at least 30 days prior to each fiscal year (July) for MWDBE service providers. Advertisements shall

be placed with minority/women-focused publications (state and local). Notification will also be sent to community organizations that might have knowledge of MWDBE firms. Interested MWDBEs shall provide a letter of interest within **14 calendar days** of the advertisement.

- c. For opportunities that arise throughout the fiscal year, PWC shall provide an Advertisement for opportunity to but not limited to MWDBE service providers within the MWDBE directory and identified MWDBEs from the Disparity Study. Advertisements shall be placed with minority/women-focused publications (state and local). Notification will also be sent to community organizations that might have knowledge of MWDBE firms. Interested MWDBEs shall provide a letter of interest within **7 calendar days**.
- d. The department heads and MWDBE Program staff should attend local and regional business fairs to promote the MWDBE Program. The departments shall also identify potentially eligible service providers through affirmative action efforts and the normal course of business. The names of identified businesses shall be forwarded to the MWDBE Program staff.

D. Request for Proposals

1. MWDBE contract goals shall be set for service contracts over \$30,000.00. The request for proposals shall state the contract goals of four (4) percent for both MWDBE Professional and General Service contractors.
2. Contracts under \$30,000 and contracts without letters of interest are not required to meet the contract goal.
3. A list of available service providers will be provided by the MWDBE Program staff to the Procurement Advisor(s) and department(s). The MWDBE Program staff shall track and report the service providers that are notified and that provide proposals.

E. Meeting MWDBE Aspirational Goals

1. Goals must be met by awarding contracts to certified MWDBE service providers. The MWDBE must be certified at the time of the contract award. MWDBE service providers not certified at the time of the contract award will not be counted towards MWDBE goals. MWDBE goals may be met by a certified joint venture or partnership. In the case of joint ventures or partnerships, MWDBE participation counted toward the goal will be equal to the percentage of the total dollar value of the contract that the MWDBE partner is responsible for performing.

F. Counting MWDBE Participation

1. The total dollar value of a contract with a disadvantaged business owned and controlled by a minority woman is counted toward either the minority goal or the goal for women, but not toward both. The contractor or MWDBE Program staff

may choose the goal to which the value is applied.

2. If a determination is made by the MWDBE Program staff that the goals have not been met, the prime service provider will be required to submit a good-faith effort statement prior to PWC awarding the contract.

G. Provider Good-Faith Efforts

The following is a list of the efforts that should be made by the prime service provider to encourage MWDBE participation. In order to receive credit for having made "good faith efforts", the prime service provider should document all actions taken to include the following:

1. Attending pre-bid meetings scheduled by the department;
2. Identifying selected specific items of the project which could be executed by a MWDBE;
3. Soliciting MWDBE service provider participation in a reasonable time before the proposals are due through advertisements in circulation media, trade publications, and minority-focused media;
4. Contacting local firms, firms owned by minorities or women, and associations or business development centers which disseminate information to local businesses and businesses owned by minorities or women in a timely manner to allow sufficient time for MWDBEs to respond;
5. Following up on initial solicitations of interest by contacting the MWDBE to determine whether the MWDBE was interested in performing specific items of the project;
6. Attempting to enter into joint venture or partnership arrangements with MWDBEs and provide interested MWDBEs with information about the requirements for the project;
7. Providing assistance to MWDBEs in the review of proposals and work to be done by sub-service providers;
8. Using available directories of certified MWDBEs and other available resources;
9. Ensuring that the proposer negotiated in good faith with the MWDBE and did not unjustifiably reject as unsatisfactory quotes prepared by any Minority, Women, or Disadvantaged Business Enterprise;
10. Making every effort to obtain Minority, Women, or Disadvantaged Business Enterprise participation that could reasonably be expected to produce a level of participation sufficient to meet the goals of PWC; and
11. Providing interested minority, women, and disadvantaged businesses with information relative to project requirements.

I. Documenting Good-Faith Efforts

If the prime service provider does not meet the goals for MWDBE participation at the time the proposals are due, then the following documents indicating "good-faith efforts" should be submitted as a minimum:

1. A report of all proposals received by the prime service provider from MWDBE sub-providers must indicate the action taken by the prime service provider in response to the proposal. In cases where proposals have been rejected, the reason for rejection must be indicated.
2. Documentation of efforts to enter into agreements with MWDBEs for sub-provider work or arrangements for joint ventures, partnerships, or other multi-entity relationships. Also included should be a statement of why agreements or arrangements were not made.
3. Proof of contact with MWDBEs and associations or business development centers that disseminate information to MWDBEs.
4. A copy of emails or notices sent to groups in Section VI, J(3) above notifying them of the firm's intent to submit a qualification submittal to PWC. The emails or notices should indicate the areas of work available for sub-providers.
5. Description of assistance provided to MWDBEs in review of the qualification submittal and work to be done by the sub-provider.
6. Description on use made by firms of available resources such as directories of MWDBEs.
7. Documentation of advertisements sent to general circulation media, trade publications, and minority-focused media.
8. Proof of attendance at any pre-bid meeting.

If the prime service provider fails to meet the MWDBE goals with its proposed project team and cannot provide documentation of "good-faith efforts", these failures will be noted to the involved department by the MWDBE Program Staff, and the service provider may be disqualified.

VIII. UTILIZATION OF JOINT VENTURE

PWC is committed to promoting the utilization of joint venturing amongst business enterprises and to support, encourage, and offer procurement opportunities to support utilization when available so that business enterprises can meet capacity development.

The purpose of Joint Venturing is to connect high potential MWDBEs with a Prime Contractor that will supplement their growth and development. Joint Venturing is seen as an important approach to help MWDBEs compete for larger contracts. PWC conducts many outreach events to connect certified MWDBEs with PWC decision makers and prime contractors. PWC shall provide targeted outreach, training, and technical support

to MWDBEs and urge Prime contractors to provide an equivalent level of outreach and support when joint venturing is available. PWC's mission is to provide an innovative program to the industry that focuses on the accelerated growth of diverse partnerships.

IX. MWDBE REPORTING PROCEDURE

1. The MWDBE Program staff shall submit quarterly progress reports to PWC Departments. The quarterly progress reports shall be prepared by the MWDBE Program staff from information (i.e. pay applications, MWDBE forms, and requisition checklist form) submitted by each department involved in procurement within thirty (30) days following the period (each quarter). Progress reports shall indicate the type of procurement contract (i.e., construction, A&E, purchase, professional services, or general services) and shall include the following:
 - vi. Number and dollar value of total procurement contracts;
 - vii. Number and dollar value of all procurement contracts awarded to MWDBEs by the department;
 - viii. Where goals are not met, the progress report shall specify the reasons and include recommendations for increasing participation.
2. PWC General Manager/CEO or its designee shall submit an annual report to Commission. The report shall include the total number of procurement contracts by departments and the dollar value of all contracts with MWDBE participation. The level of MWDBE participation shall be reported annually.

**FAYETTEVILLE PUBLIC WORKS COMMISSION'S
MWDBE COMPLIANCE PROVISIONS**

APPLICATION:

The requirements of Fayetteville Public Works Commission (PWC) Minority, Women, and Disadvantaged Business Enterprise (MWDBE) Program for participation specific contracts are hereby made part of the Contract Documents. Copies of the Program may be obtained from:

Fayetteville Public Works Commission
Economic Inclusion Programs
P.O. Box 1089
Fayetteville, North Carolina 28302
Phone (910) 223-4016 Fax (910) 483-1429
E-mail: EIProgram@faypwc.com

NCDOT DBE Directory: www.ebs.nc.gov/VendorDirectory

HUB Directory: <https://ncadmin.nc.gov/businesses/hub>

MWDBE Compliance Requirements:

1. The Bidder shall provide, with their Bid Form, at the time bids are due, the documents set forth below, properly executed. Returning executed copies indicates and establishes that the Bidder understands and agrees to any incorporated MWDBE contract provisions.
2. All Bidders must provide with their Bid Form, at the time bids are due, a properly completed and executed copy of **either:**
 - Affidavit A – Listing of Good-Faith Efforts **OR**
 - *Affidavit B – Intent to Self-Perform with Own Workforce.

*Affidavit B should **only** be used if the Contractor will perform **ALL Elements** of the Work on this project with their own forces **AND** will complete **ALL Elements** of this project **WITHOUT** the use of subcontractors, material suppliers, or providers of professional services.
3. Upon being identified as the apparent lowest responsive, responsible Bidder, a Bidder shall, within twenty-four (24) hours of PWC's notification provide a properly completed and executed copy of **either:**
 - Affidavit C – Percentage of MWDBE Participation **OR**
 - Affidavit D – Good-Faith Efforts.
4. All Bidders must provide with their Bid Form, at the time bids are due, a properly completed and executed copy of Affidavit E- Identification of MWDBE/Local Participation Form

All written statements, certifications, or intentions made by the Bidder shall become a part of the agreement between the Contractor and Fayetteville Public Works Commission for performance of this contract.

SUBCONTRACTOR PAYMENT REQUIREMENTS:

North Carolina General Statutes 143-134.1 (N.C.G.S.) states that the percentage of retainage on payments made by the prime contractor to the subcontractor shall not exceed the percentage of retainage on payments made by the Fayetteville Public Works Commission to the prime contractor. Failure to comply with this provision shall be considered a breach of the contract, and the contract may be terminated in accordance with the termination provisions of the contract.

The Contractor shall provide an itemized statement of payments to each MWDBE subcontractor before final payment is processed.

The Contractor shall provide an itemized statement of payments to each NON-MWDBE subcontractor before final payment is processed.

Contractor

Signature

Printed Name

Title

Date

Affidavit A: Listing of the Good Faith Efforts

Affidavit of _____
(Name of Bidder)

I have made a good faith effort to comply under the following areas checked:

Total Available GFE Points: 155		Minimum Number GFE Points Required: 50
Points		
10	10	Contacting minority businesses that reasonably could have been expected to submit a quote and that were known to the contractor or available on State or local government-maintained lists at least 10 days before the bid or proposal date and notifying them of the nature and scope of the work to be performed.
10	10	Making the construction plans, specifications and requirements available for review by prospective minority businesses or providing these documents to them at least 10 days before the bid or proposals are due.
15	15	Breaking down or combining elements of work into economically feasible units to facilitate minority participation.
10	10	Working with minority trade, community, or contractor organizations identified by the Office for Historically Underutilized Businesses and included in the bid documents that provide assistance in recruitment of minority businesses.
10	10	Attending any pre-bid meetings scheduled by the public owner.
20	20	Providing assistance in getting required bonding or insurance or providing alternatives to bonding or insurance for subcontractors.
15	15	Negotiating in good faith with interested minority businesses and not rejecting them as unqualified without sound reasons based on their capabilities. Any rejection of a minority business based on lack of qualification should have the reasons documented in writing.
25	25	Providing assistance to an otherwise qualified minority business in need of equipment, loan capital, lines of credit, or joint pay agreements to secure loans, supplies, or letters of credit, including waiving credit that is ordinarily required. Assisting minority businesses in obtaining the same unit pricing with the bidder's suppliers in order to help minority businesses in establishing credit.
20	20	Negotiating joint venture and partnership arrangements with minority businesses in order to increase opportunities for minority business participation on a public construction or repair project when possible.
20	20	Providing quick pay agreements and policies to enable minority contractors and suppliers to meet cash-flow demands.
Total GFE Points (Claimed by Bidder):		Total GFE Points (Assessed by PWC):

In accordance with NCGS 143-128.2(d) the undersigned will enter into a formal agreement with the firms listed in the Identification of Small Disadvantaged Business Participation schedule conditional upon execution of a contract with the Owner. Failure to abide by any applicable statutory provision may constitute a breach of the contract. The undersigned hereby certifies that he or she has read the terms of the MWDBE business commitment and is authorized to bind the Bidder to the commitment herein set forth.

Date: _____ Name of Authorized Officer: _____



State of North Carolina, County of _____

Subscribed and sworn to before me this _____ day of 20__

Notary Public _____

My commission expires _____

Affidavit B: Intent to Perform Contract with Own Workforce

Affidavit of _____
(Name of Bidder)

I hereby certify that it is our intent to perform 100% of the work required for contract:

(Name of Project)

In making this certification, the Bidder states that the Bidder does not customarily subcontract elements of this type project, and normally performs and has the capability to perform and will perform **all elements of the work** on this project with his/her own current workforces; and will complete all elements of this project **without** the use of subcontractors, material suppliers, or providers of professional services.

The Bidder agrees to provide any additional information or documentation requested by the Owner in support of the above statement.

The undersigned hereby certifies that he or she has read this certification and is authorized to bind the Bidder to the commitments herein contained.

Date: _____ Name of Authorized Officer: _____

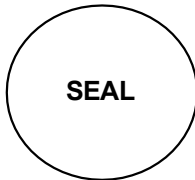

State of North Carolina, County of _____

Subscribed and sworn to before me this _____ day of 20____

Notary Public _____

My commission expires _____

Affidavit C: Percentage of MWDBE Participation

Affidavit of _____
(Name of Bidder)

I hereby certify that on contract: _____
(Name of Project)

\$ _____
(Dollar Amount of Total Bid)

I will expend a minimum of _____% of the total dollar amount of the contract with Minority, Women, and Disadvantaged Business Enterprises (MWDBE). MWDBEs will be employed as subcontractors, vendors, or providers of professional services. Such work will be subcontracted to the following firms listed below.

<u>Name, Address, & Phone No.</u>	<u>*MWDBE Category</u>	<u>NAICS</u>	<u>Dollar Value</u>	<u>% of Contract</u>

*MWDBE categories: Black-African Americans (B), Hispanic-Americans (H), Asian- Americans (A), Native-Americans (I), Women (F), Socially/Economically Disadvantaged (D)

Pursuant to NCGS 143-128.2(d), the undersigned will enter into a formal agreement with MWDBEs for work listed in this schedule conditional upon execution of a contract with the Owner. Failure to fulfill this commitment may constitute a breach of the contract.

The undersigned hereby certifies that he or she has read the terms of this commitment and is authorized to bind the Bidder to the commitment herein set forth.

Date: _____ Name of Authorized Officer: _____

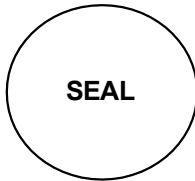

State of North Carolina, County of _____

Subscribed and sworn to before me this _____ day of 20__

Notary Public _____

My commission expires _____

Affidavit D: Good Faith Efforts

If Owner determines using reasonable discretion that Affidavit C is insufficient, Bidder agrees to provide the following information regarding any good-faith efforts.

<u>Name, Address, & Phone No.</u>	<u>*MWDBE Category</u>	<u>NAICS</u>	<u>Dollar Value</u>

*MWDBE categories: Black-African Americans (B), Hispanic-Americans (H), Asian- Americans (A), Native-Americans (I), Women (F), Socially/Economically Disadvantaged (D)

Bidder may be requested to provide documentation of the Bidder's good-faith efforts. Examples of documentation may include the following:

- a. Copies of solicitations for quotes to MWDBEs. Each solicitation may include a specific description of the work to be subcontracted, location where bid documents can be reviewed, representative of the Prime Bidder to contact, and location, date and time when quotes must be received.
- b. Copies of quotes or responses received from each firm responding to the solicitation.
- c. A telephone log of follow-up calls to each firm sent a solicitation.
- d. For subcontracts where a MWDBE is not considered the lowest responsible sub-bidder, copies of quotes received from all firms submitting quotes for that particular subcontract.
- e. Documentation of any contacts or correspondence to MWDBE, community or contractor organizations in an attempt to meet the goal.
- f. Copy of pre-bid roster.
- g. Letter documenting efforts to provide assistance in obtaining required bonding or insurance for MWDBEs.
- h. Letter detailing reasons for rejection of a MWDBE due to lack of qualification.
- i. Letter documenting proposed assistance offered to MWDBEs in need of equipment, loan capital, lines of credit, or joint pay agreements to secure loans, supplies, or letter of credit, including waiving credit that is ordinarily required.

Failure to provide the documentation as listed in these provisions may result in rejection of the bid and award to the next lowest responsible and responsive Bidder.

Date: _____ Name of Authorized Officer: _____



State of North Carolina, County of _____

Subscribed and sworn to before me this _____ day of 20__

Notary Public _____

My commission expires _____

Affidavit E: Identification of MWDBE/Local Participation

(Name of Bidder)

I hereby certify that on contract: _____

(Name of Project)

We will use the following Minority, Women, and Disadvantaged Business Enterprises (MWDBE), and Local (Cumberland, Hoke, Harnett County) as construction subcontractors, vendors, suppliers, or providers of professional services.

<u>Name, Address, & Phone No.</u>	<u>*MWDBE Category / **Local</u>	<u>NAICS</u>	<u>Dollar Value</u>

*MWDBE categories: Black-African Americans (B), Hispanic-Americans (H), Asian- Americans (A), Native-Americans (I), Women (F), Socially/Economically Disadvantaged (D)

**Local: Fayetteville Metropolitan Statistical Area (MSA) comprising of Cumberland County, Hoke County, and Harnett County. PWC is requesting this information for reporting purposes only, and use of local entities will not be considered for compliance with the requirements of the MWDBE Program.

The total value of MWDBE/local business contracting will be \$ _____

Date: _____ Name of Authorized Officer: _____

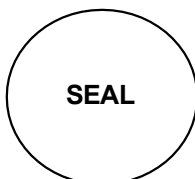

State of North Carolina, County of _____

Subscribed and sworn to before me this _____ day of 20____

Notary Public _____

My commission expires _____

**FAYETTEVILLE PUBLIC WORKS COMMISSION
MWDBE ADD / CHANGE FORM**

If a MWDBE subcontractor fails to complete work under the subcontract for any reason, the recipient must require the prime contractor to employ the good faith efforts set forth in the MWDBE Program if soliciting a replacement or additional subcontractor.

For MWDBE Change Request, please provide all information below:

Prime Contractor: _____

Subcontracted Work: _____

Previous Subcontractor: _____

Reason this for change request:

New Subcontractor: _____ MWDBE Category: _____

To Add MWDBE Subcontractor/Subcontracted work:

If this is a new trade being subcontracted or a subcontractor that was not documented in the original Project Bid Information submittal, then good faith efforts to solicit a MWDBE must be documented, as the original MWDBE instructions indicate. Please provide all good faith efforts below showing all the MWDBE firms contacted to perform this work along with any additional good faith efforts or evidence that there are not reasonably available firms in the work area. PWC's MWDBE Program requires that good faith efforts are to be carried out to the fullest extent practicable. If solicitations were not carried out due to being impracticable, please attach this explanation to this form.

Name, Address, & Contact Information	MBE or WBE and Certifying agency	How was this firm contacted (email, letter, or Phone) and what was the result of the solicitation? *

*Must submit copies of emails or letters. If phone calls were made this sheet can serve as documentation of calls

Date: _____ Name of Authorized Officer: _____

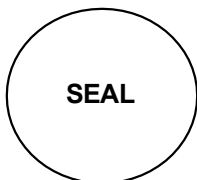

State of North Carolina, County of _____

Subscribed and sworn to before me this _____ day of 20__

Notary Public _____

My commission expires _____

SMALL LOCAL SUPPLIER / MWDBE SUBCONTRACTOR DISCLOSURE FORM

Contractor: _____
 Address & Phone: _____
 Project: _____
 Name: _____
 Pay Application # _____

Please complete the below form by providing the necessary information for the payments made to each subcontractor, vendor, or supplier for the work associated with the identified pay application. This form must be fully completed and attached to each pay application.

Firm Name, Address, and Contact Information	Payment Amount	Type of Work/Commodity (Include NAICS Code)

Signature

Printed Name

Title

Date

SECTION B - CONTRACT EXECUTION DOCUMENTS

***** THIS PAGE WAS INTENTIONALLY LEFT BLANK *****

NOTICE OF AWARD

TO: _____

PROJECT DESCRIPTION: LIFT STATION REHABILITATION

The OWNER has considered the BID submitted by you for the above described work in response to its Advertisement for Bids dated _____ and Instructions to Bidders.

You are hereby notified that your BID has been accepted for items in the amount of \$_____.

You are required by the Instructions to Bidders to execute the Agreement and furnish the required Performance Bond, Payment Bond, and Certificates of Insurance within ten (10) calendar days from the date of this NOTICE to you.

If you fail to execute said Agreement and to furnish said Bonds within ten (10) days from the date of this Notice, said Owner will be entitled to consider all your rights arising out of the OWNER's acceptance of your BID as abandoned and as a forfeiture of your Bid Bond. The Owner will be entitled to such other rights as may be granted by law.

You are required to return an acknowledged copy of this NOTICE OF AWARD to the OWNER.

Dated this _____ day of _____, 2024.

**OWNER: FAYETTEVILLE PUBLIC WORKS COMMISSION
FAYETTEVILLE, NC**

**BY: Victoria McAllister
TITLE: Procurement Manager**

ACCEPTANCE OF AWARD
LIFT STATION REHABILITATION

Receipt of the preceding NOTICE OF AWARD is hereby acknowledged this the _____
day of _____, 2024.

(CONTRACTOR)

By: _____

Title: _____

- END OF SECTION -

State of North Carolina
Cumberland County

ON-CALL CONSTRUCTION AGREEMENT

THIS ON-CALL CONSTRUCTION AGREEMENT (“Agreement” or “Contract”) is made by and between Fayetteville Public Works Commission (“PWC”), a North Carolina public authority, [PER OUR CHARTER (SEE SEC 6A.20), THE CONSTRUCTION CONTRACT, IF MORE THAN \$500K, MUST BE BETWEEN THE CITY (BY AND THROUGH PWC) AND THE CONTRACTOR], and _____ (“Contractor”), a North Carolina _____ (each of PWC and Contractor is referred to herein as a “Party” and collectively as the “Parties”) as of the date of execution last written below (the “Effective Date”). For good and valuable consideration, the receipt and sufficiency of which is hereby acknowledged, the Parties agree as follows:

RECITALS

PWC requires the services of a _____ to provide will provide timely, cost-effective and quality on-call construction and repair services for various projects which can be small in scope and usually immediate in terms of need. Individual On-Call Requests dollar values and completion times will vary depending on the type and amount of work assigned and the rate at which appropriated of funds are consumed. The availability of the Contractor and its response times are of the utmost importance.

1. Scope of Services. The following is a general description of the tasks that may be required by PWC pursuant to this Agreement. The list is not intended to be all-inclusive, nor is it guaranteed that all of the listed tasks will be assigned.

Upon receipt of a “Notice to Proceed”, Contractor agrees to perform the Authorized Work requested and authorized by PWC pursuant to an On-Call Request. For purposes of this Agreement, an “On-Call Request” means an independent, specific, written work assignment issued to Contractor by PWC outlining a detailed scope of Services to be performed, including some or all of the above-described tasks, applicable timelines, and any other relevant specifications.

Contractor shall furnish and bear solely the entire cost of all labor and materials to perform the Work in a workmanlike manner in strict accordance with the Contract Documents, schedule delivery of the new materials, furnish and bear solely the entire cost of all supervision, contract administration, equipment, tools, and other means necessary to complete the Work, perform every obligation imposed by the Contract Documents, and be solely responsible for the clean-up and disposal of all materials and debris relating to or arising from the construction and renovation, subject to any exceptions that are specifically set forth in the Contract Documents. Except as otherwise specifically provided in the Contract Documents, Contractor is solely responsible for all construction means, methods, techniques, sequences, procedures, safety precautions or programs, supervising, coordinating, and performing the tasks necessary to complete the Work; provided, however, PWC shall have the right, without incurring any liability to Contractor, to suspend Contractor’s performance when a PWC employee, in his or her opinion, observes a safety violation involving a threat to life or imminent danger of bodily injury,

and the suspension shall remain in effect until Contractor remedies the safety violation.

2. Definitions. Capitalized terms used in this Agreement have the meaning specified below:

“Authorized Work” means the specific work requested and authorized pursuant to an On-Call Request.

“Business Day” means each calendar day that is not a Saturday, Sunday, holiday observed by the federal government for its employees, or holiday observed by PWC for its employees.

“Completion of the Authorized Work” means: (i) the Authorized Work is completed in accordance with this Agreement, except for punch list items; (ii) PWC has received any required temporary or final certificate of occupancy from the governmental agency with jurisdiction over the Authorized Work; and (iii) the registered architects or engineers (the “Designer(s)”) who designed portions or components of the Authorized Work have issued certificates of Completion of the Authorized Work as to those portions or components.

“Contract Documents” means the following documents that were either made available to Contractor by PWC during the bid solicitation process (including Drawings) or executed by the Parties or both, which are all incorporated by reference herein:

- a. This Agreement
- b. Bid Documents
- c. Contractor’s Submitted Bid
- d. Bid Bond
- e. Form of Exceptions
- f. Notice of Award
- g. Acceptance of Award
- h. Performance Bond
- i. Payment Bond
- j. Copy of General Contractor’s License
- k. Certificate of Insurance
- l. Technical Specifications
- m. Additional Specifications

The following documents may be delivered or issued on or after the Effective Date of the Agreement and may not be attached to this Agreement, but are considered Contract Documents when executed by the Parties:

- n. On-Call Request and Notice to Proceed
- o. Authorized Work Change Directive(s)
- p. Change Order(s)
- q. Field Order(s)

There are no Contract Documents other than those identified in this Agreement. The Contract Documents may only be amended, modified, or supplemented as provided in this Agreement in a writing signed by the Parties.

“Fault” means a breach of contract by Contractor, negligent, reckless, or intentional act(s) or omission(s) constituting a tort under applicable statutes or common law by one or more Responsible Persons, or violation(s) of applicable statute(s) or regulation(s) by a Responsible Person.

“Responsible Person” means Contractor and each of its employees, agents, representatives, subcontractors, or other persons and entities for which Contractor may be liable or responsible as a result of any statutory, tort, or contractual duty.

“Work” means all Authorized Work, collectively.

The terms used in this Agreement shall have the meaning as stated herein and in the Contract Documents. In the event of a conflict between the terms of this Agreement and any other component(s) of the Contract Documents, the terms of this Agreement shall govern.

3. Contract Prices. On-Call Requests will be issued individually on a “not to exceed” basis. Authorized Work shall be billed based on the hourly rates set forth on Exhibit A, attached hereto and made a part hereof by this reference. PWC shall pay Contractor for Completion of the Authorized Work in accordance with the Contract Documents the amount identified in the applicable On-Call Request (the “Price”). Contractor understands and acknowledges that the Price is derived from a specific appropriation of funds provided for the Work. Contractor agrees and acknowledges the Price is equal to the aggregate cost of all Authorized Work to be done pursuant to the applicable On-Call Request, including all labor, materials, equipment, apparatus, and supplies. Contractor acknowledges and agrees that there is no guarantee that the amount appropriated will be fully expended.

4. Term. The initial term of this Contract shall be for two (2) years commencing on the Effective Date (the “Initial Term”); provided, however, that PWC may terminate this Contract for convenience at any time following the expiration of the first year of the Initial Term by giving the Contractor written notice of termination. At the expiration of the Initial Term, this Contract will automatically renew for an additional one (1) year period unless a Party provides the other Party with notice of its intent not to renew this Agreement at least ninety (90) days prior to the expiration of the Initial Term.

The duration of the Authorized Work shall be as set forth in the applicable On-Call Request issued under this Contract, which shall be attached hereto and made an integral part hereof. The Parties shall perform their obligations under this Agreement in compliance with all scheduling deadlines set forth in the On-Call Request. Contractor shall commence the Authorized Work on the date to be specified in the Notice to Proceed issued by PWC. Contractor shall achieve Completion of the Authorized Work on the date specified in the On-Call Request, plus any modifications thereof allowed in accordance with the Contract Documents (the “Completion Date”).

5. Payment. PWC shall pay Contractor in installment payments plus a final payment, as set forth in the Contract Documents. For each applicable installment payment, Contractor shall submit an application for payment in accordance with the Contract Documents. An application for payment will be processed by PWC as provided in the Contract Documents.

Such installment payments shall reflect the actual cost of the Authorized Work, not to exceed in total the Price, and the allocable portion of the total Price for said installment. PWC shall make payment to Contractor, less any applicable retainage set forth in the Contract Documents; provided, however, that PWC may withhold all or a portion of a payment on account of (1) incomplete Authorized Work, (2) defective or nonconforming Authorized Work, (3) claims filed or a reasonable basis to believe that such claims will be filed imminently, (4) failure of Contractor to make payments properly for labor, services, materials, equipment or subcontracts, (5) damages caused to PWC or another party by one or more Responsible Persons, or (6) failure to comply with the terms and conditions of this Agreement. In the final payment, PWC shall pay the balance of the Price, including all retained amounts, less any Liquidated Damages and other applicable damage and claim amounts, to Contractor within forty-five (45) days of Completion of the Authorized Work; provided, however, that PWC may withhold a reasonable sum from the final payment to ensure correction of any final items or condition of the Authorized Work.

6. Retainage. Subject to any restrictions applicable to any federal grant funds that may be utilized for the Authorized Work, PWC may, in its discretion, retain up to five percent (5%) of any periodic payment due Contractor; provided, however, when the Authorized Work is fifty percent (50%) complete, PWC, with written consent of the surety, shall not retain any further retainage from periodic payments due Contractor if Contractor continues to perform satisfactorily and any nonconforming Authorized Work identified in writing prior to that time by PWC or the Designer has been corrected by Contractor and accepted by PWC or the Designer, and provided further that full payment, less authorized deductions, shall also be made for those line item trades that have reached one hundred percent (100%) completion of their contract obligations by or before the Authorized Work is fifty percent (50%) complete if Contractor has performed satisfactorily in accordance with G.S. 143-134.1(b2), contingent upon PWC's receipt of an approval or certification from the Designer that the Authorized Work performed by the subcontractor is acceptable and in accordance with the Contract Documents. If PWC determines Contractor's performance is unsatisfactory, PWC may, in its discretion, reinstate retainage for each subsequent periodic application for payment as authorized in this Section up to the maximum amount of five percent (5%). The Authorized Work shall be deemed fifty percent (50%) complete when Contractor's gross project invoices, excluding the value of materials stored off-site, equal or exceed fifty percent (50%) of the Price, except the value of materials stored on-site shall not exceed twenty percent (20%) of Contractor's gross project invoices for the purpose of determining whether the Authorized Work is fifty percent (50%) complete. Within 60 days after the submission of a pay request and one of the following occurs, as specified in the Contract Documents, PWC, with written consent of the surety, shall release to Contractor all retainage on payments held by PWC: (i) PWC receives a certificate of substantial completion from the Designer in charge of the Authorized Work; or (ii) PWC receives beneficial occupancy or use of the Authorized Work; provided, however, PWC may in its discretion retain sufficient funds to secure Completion of the Authorized Work or corrections and punch list items on any Authorized Work. If PWC retains funds, the amount retained shall not exceed two and one-half times the estimated value of the Authorized Work to be completed or corrected or addressed in the punch list. Any reduction in the amount of the retainage on payments shall be with the consent of Contractor's surety. The existence of any third-party claims against Contractor or any additive change orders to the Construction Documents shall not be a basis for delaying the release of any retainage on payments. Notwithstanding anything in this Section to the contrary, following fifty percent (50%) completion of the Authorized Work, PWC shall be authorized to withhold additional retainage from a subsequent periodic payment, not to exceed five percent (5%), in order to allow PWC to retain two and one-half percent (2.5%) total retainage through the Completion of the Authorized Work. In the event that PWC elects to withhold additional retainage on any periodic payment subsequent to release of retainage on a

line-item of Authorized Work pursuant to G.S. 143-134.1(b2), Contractor may also withhold from the subcontractors remaining on the project sufficient retainage to offset the additional retainage held by PWC, notwithstanding the actual percentage of retainage withheld by PWC of the Authorized Work as a whole. Neither PWC's nor Contractor's release of retainage on payments as part of a payment in full on a line-item of Authorized Work pursuant to G.S. 143-134.1(b2) shall affect any applicable warranties on Authorized Work done by Contractor or subcontractor, and the warranties shall not begin to run any earlier than either PWC's receipt of a certificate of substantial completion from the Designer in charge of the Authorized Work or PWC receives beneficial occupancy.

7. Liquidated Damages. Time is of the essence with respect to performance of each of the Parties' obligations under this Agreement. Contractor recognizes and acknowledges that PWC will suffer financial and other losses if the Authorized Work is not completed by its Completion Date. The Parties recognize and agree that the delays, expense, and difficulties involved in proving in a legal or arbitration proceeding the actual loss suffered by PWC if the Authorized Work is not completed by the Completion Date. Accordingly, instead of requiring any such proof, Contractor and PWC agree that in the event Contractor fails to achieve Completion of the Authorized Work by its Completion Date, Contractor shall pay to PWC as liquidated damages to compensate PWC for damages related to the delayed Completion of the Authorized Work one thousand dollars (\$1000.00) per day ("Liquidated Damages") for each calendar day Contractor fails to achieve Completion of the Authorized Work by the Completion Date.

PWC and Contractor acknowledge and agree that the sums payable under this Section 7 shall constitute liquidated damages and not penalties and are in addition to all other rights of PWC, including the right to call a default. The parties further acknowledge that (i) the amount of loss or damages likely to be incurred is incapable or is difficult to precisely estimate, (ii) the amounts specified bear a reasonable relationship to, and are not plainly or grossly disproportionate to, the probable loss likely to be incurred in connection with Contractor's failure fails to achieve Completion of the Authorized Work, (iii) one of the reasons for PWC and Contractor reaching an agreement as to such amounts was the uncertainty and cost of litigation regarding the question of actual damages, and (iv) PWC and Contractor are sophisticated business parties and have been represented by sophisticated and able legal counsel and negotiated this Agreement at arm's length.

8. Contractor's Representations and Warranties. In order to induce PWC to enter into this Agreement, Contractor makes the following representations and warranties to PWC which shall be true and correct on the Effective Date and on the date of issuance of each On-Call Request under this Contract:

a. Contractor is duly licensed in the State of North Carolina to complete the Work, is duly organized, validly existing and in good standing and has all requisite powers, rights, and authority to execute, enter into, and perform this Agreement in accordance with the terms and conditions of this Agreement, and this Agreement constitutes a legal, valid, and binding obligation of Contractor enforceable against it in accordance with its terms.

b. Contractor has read the Contract Documents, and acknowledges and understands all data, materials, specifications, and requirements identified in the Contract Documents.

- c. Contractor is familiar with and is satisfied as to all laws and regulations that may affect cost, progress, and performance to complete the Work.
- d. Prior to undertaking any Authorized Work, Contractor shall have:
- (i) visited the site for the Authorized Work, conducted a thorough, visual examination of the site and adjacent areas, and become familiar with and is satisfied as to the general, local, and site conditions that may affect cost, progress, and performance in completing the Authorized Work..
 - (ii) Contractor shall have carefully studied all: (1) reports of explorations and tests of subsurface conditions at or adjacent to the site and all drawings of physical conditions relating to existing surface or subsurface structures at the site that have been identified in the Contract Documents and any accompanying reports and drawings, and (2) reports and drawings relating to Hazardous Environmental Conditions, if any, at or adjacent to the site that have been identified in the Contract Documents and any accompanying reports and drawings.
 - (iii) Contractor shall have considered the information known to Contractor itself; information commonly known to contractors doing business in the locality of the site; information and observations obtained from visits to the site; the Contract Documents; and the site-related reports and drawings identified in the Contract Documents, if any, with respect to the effect of such information, observations, and documents on (1) the cost, progress, and performance of the Authorized Work; (2) the means, methods, techniques, sequences, and procedures of construction to be employed by Contractor; and (3) Contractor's safety precautions and programs.
 - (iv) Based on the information and observations referred to in subparagraph (iii) of this subsection d, Contractor shall have satisfied itself that no further examinations, investigations, explorations, tests, studies, or data are necessary for the performance of the Authorized Work at the applicable Price commencing on the commencement date set forth in the Notice to Proceed and in accordance with the other terms and conditions of the Contract.
 - (v) Contractor shall have made itself aware of the general nature of the Authorized Work to be performed by PWC and others at the site that as indicated in the Contract Documents.
- e. Prior to undertaking any Work, Contractor shall have given PWC's Designer written notice of all conflicts, errors, ambiguities, or discrepancies that Contractor has discovered in the Contract Documents, and the written resolution thereof by the Designer is acceptable to Contractor.
- f. The Contract Documents are generally sufficient to indicate and convey understanding of all terms and conditions for performance and furnishing of the Work.
- g. Contractor's entry into this Agreement constitutes an incontrovertible

representation by Contractor that, without exception, all prices in the Agreement are premised upon performing and furnishing the Work required by the Contract Documents.

h. Contractor has no business or personal relationship with any PWC Commissioner, officer, director, manager, or supervisor and Contractor covenants to disclose immediately to PWC any such relationship that develops during the performance of the Work.

9. Contractor's Payment Obligations. Contractor shall pay all of its obligations arising out of or in connection with the Work in a timely manner to all persons supplying materials in the prosecution of the Work and to all laborers and others employed thereon.

10. Performance and Payment Bonds. Contractor shall obtain and deliver to PWC a performance bond in an amount based on the estimated cost of the Authorized Work, conditioned upon the faithful performance of all Authorized Work in accordance with the Contract Documents, which bond shall be solely for the protection of PWC. Contractor shall obtain and deliver to PWC a payment bond in the amount of one hundred percent (100%) of the estimated cost of the Authorized Work, conditioned upon the prompt payment for all labor or materials for which Contractor or one or more of its subcontractors is liable, which payment bond shall be solely for the protection of the persons furnishing materials or performing labor for which Contractor is liable. The performance bond and the payment bond shall be executed by one or more surety companies legally authorized to do business in the State of North Carolina, shall become effective upon the awarding of the construction contract by PWC to Contractor, and shall at all times comply with the requirements set forth in Article 3 of North Carolina General Statutes Chapter 44A. In the event PWC deems the surety or sureties upon any bond necessary for this Agreement and the Completion of the Authorized Work, or if for any reason, such bond ceases to be adequate to cover the performance and/or payment of the Authorized Work, Contractor shall, at its expense, within five (5) days after the receipt of notice from PWC, furnish an additional bond or bonds in such form and amount, and with such surety or sureties as shall be satisfactory to PWC. In such event no further payment to Contractor shall be deemed to be due under this Agreement until new or additional security for the performance and payment of the Authorized Work shall be furnished in manner and form satisfactory to PWC. Contractor understands and acknowledges that PWC, as a public authority, is not subject to the provisions of Articles 1 and 2 of Chapter 44A of the General Statutes, in accordance with G.S. 44A-34 and applicable law.

11. Contractor's Damage Repair Obligations. Contractor shall be responsible for all damages to the property of the City of Fayetteville and of PWC that may result from the normal procedure of a Responsible Person's actions in the prosecution of the Work or that may be caused by or result from the negligence of a Responsible Person during the progress of or connected with the prosecution of the Work, whether within the limits of the Work or elsewhere. Contractor shall promptly restore all such property so damaged to a condition as good as it was immediately prior to Contractor initiating the Work .

12. Defective Work. The Project shall be subject to observation and approval by PWC, Designer, and representatives of governmental agencies with jurisdiction over the Project. PWC and Designer shall be entitled to enter at all reasonable times the premises subject to construction or renovation to inspect the Work performed by or on behalf of Contractor, provided that such entry and inspection does not materially interfere with the progress of construction. Contractor shall correct promptly, at no cost to PWC, all Work

reasonably rejected by PWC or by its representatives. Should Contractor fail to correct rejected Work, PWC may, acting in its sole discretion, correct such Work and the Contractor shall pay PWC's actual costs of correction and any other applicable amounts identified in the Contract Documents.

13. As-Built Drawings. Contractor shall maintain during the progress of the Authorized Work as-built drawings indicating the current status of the Authorized Work as actually performed. Upon Completion of the Authorized Work, Contractor shall prepare a final version of such as-built drawings and submit them to PWC for approval.

14. Assignment. This Agreement shall be binding upon and inure to the benefit of the Parties, their legal representatives, successors, and assigns. Contractor may not assign, transfer, convey, or encumber, whether voluntarily or by operation of law, this Agreement or any obligations, rights under, or interests in this Agreement to a third party without the prior written consent of PWC; and, specifically, but without limitation, money that may become due and money that is due may not be assigned without such consent (except to the extent that the effect of this restriction may be limited by law), and unless specifically stated to the contrary in any written consent to an assignment, no assignment will release or discharge the assignor from any duty or responsibility under the Contract Documents.

15. Indemnity. Contractor shall indemnify, defend, and hold harmless PWC and its Commissioners, officers, employees, agents, and representatives and the City of Fayetteville and its elected officials, managers, employees, agents, and representatives and Design Engineer (collectively "Indemnitees") from and against all claims, actions, liabilities, damages, losses, costs, and expenses (including, without limitation, injury to or death of any persons and damage to property, economic and consequential damages and attorneys' fees) asserted by one or more third parties against one or more of the Indemnitees if the Fault of one or more Responsible Persons is a proximate cause of the loss, damage, or expense indemnified. Contractor's obligation to indemnify, defend, and hold harmless the Indemnitees shall survive the termination of this Agreement.

16. Insurance. Contractor shall maintain during the performance of the Work and for at least three (3) years after the Completion of the Work the insurance coverage set forth in the Contract Documents, which insurance shall be placed with insurance companies authorized to do business in the State of North Carolina and rated A minus VII or better by the current edition of Best's Key Rating Guide or otherwise approved in writing by PWC. Prior to initiating any Work, Contractor shall deliver certificates of insurance confirming each such coverage required by the Contract Documents, and Contractor shall direct its insurers to provide annually to PWC certificates confirming each such coverage during the coverage period. PWC shall be named as an additional insured in the comprehensive automobile and commercial liability insurance policies. Commercial general liability coverage shall be written on an "occurrence" basis. Contractor shall not reduce or allow the required insurance coverages to lapse without PWC's prior written approval. All policies for insurance must be endorsed to contain a provision giving PWC a thirty (30) calendar day prior written notice by certified mail of any cancellation of that policy or material reduction in coverage. Should a notice of cancellation be issued for non-payment of premiums or any part thereof, or should Contractor fail to provide and maintain certificates as set forth herein, PWC shall have the right, but shall not have the obligation, to pay such premium to the insurance company or to obtain such coverage and to deduct such payment from any sums that may be due or become due to Contractor, or to seek reimbursement for said payments from Contractor. Any such sums paid by PWC shall be due and payable immediately by Contractor upon notice from PWC. The insurance provisions of this

Agreement shall not be construed as a limitation on Contractor's responsibilities and liabilities pursuant to the terms and conditions of this Agreement. Contractor's obligation to maintain insurance for three (3) years after Completion of the Work shall survive the termination of this Agreement.

17. Warranty. Contractor hereby grants to PWC warranties on all materials and Workmanship involved in the Work for a period of one (1) year from the date of Completion of the Authorized Work and a period of two (2) years from the date of Completion of the Authorized Work for any latent structural defects. PWC shall give written notice to Contractor of any claim under this Section within the time specified hereinabove. These warranties shall be in addition to, and not in derogation of, all other rights and privileges which PWC may have under law, equity, or instrument, and shall survive the date of Completion of the Authorized Work and the final settlement and shall be binding on Contractor notwithstanding any provision in any other writing executed by PWC heretofore or contemporaneous with the execution of the Agreement or prior to the date of Completion of the Authorized Work.

18. Waiver. No failure on the part of any party to exercise, and no delay in exercising, any right, power, or privilege hereunder shall operate as a waiver thereof, nor shall any single or partial exercise of any right hereunder preclude any other or further cumulative and not exclusive of any remedies provided by law. This Agreement shall be binding upon and inure to the benefit of the parties, their legal representatives, successors, and assigns. This Agreement may not be assigned, transferred, conveyed, or encumbered, whether voluntarily or by operation of law, by either party without the prior written consent of the other party, which consent shall not be unreasonably withheld.

19. Law. THIS AGREEMENT SHALL BE GOVERNED BY AND INTERPRETED AND ENFORCED IN ACCORDANCE WITH THE LAWS OF THE STATE OF NORTH CAROLINA WITHOUT GIVING EFFECT TO THE CHOICE OF LAW PROVISIONS THEREOF. Contractor shall at all times comply with all applicable Federal, state, and local laws and building codes in the performance of its obligations under the Agreement.

20. Dispute Resolution. In the event of any dispute, controversy, or claim of any kind or nature arising under or in connection with this Agreement (a "Dispute") and involving any two or more of the following parties, PWC, Designer, Contractor or any subcontractor of Contractor, the party initiating the Dispute shall serve written notice of a Dispute on the party(ies) to the dispute, and those parties shall endeavor to settle the dispute first through direct, informal discussions between the parties' selected representatives. Any such representative(s) shall have binding authority to settle the Dispute. In the event the parties do not settle the Dispute within ten (10) days from the date of written notice of the Dispute, any party to the Dispute may, by written notice to the other party(ies), engage a mediator certified under the laws of the State of North Carolina to mediate the Dispute within thirty (30) days of such notice. The parties to the Dispute shall attend mediation in good faith. In the event mediation is unsuccessful, any party to the dispute may initiate arbitration proceedings. Any controversy or claim arising out of or relating to the Contract Documents, or the breach thereof, shall be settled by binding arbitration administered by the American Arbitration Association under its Construction Industry Arbitration Rules, and judgment on the award rendered by the arbitrator(s) may be entered in any court having jurisdiction thereof. All of the foregoing dispute resolution procedures shall be held in Cumberland County, North Carolina. The costs of the mediator and arbitrator in a dispute resolution process shall be divided equally among the parties to the process; provided, however, PWC shall bear at least one-third of the cost if PWC is a party to the dispute resolution and the remainder of the cost shall be divided equally among the other parties participating in

the dispute resolution. PWC shall, in its contractual arrangements with Designer, and Contractor shall, in its contracts with subcontractors and they in their contracts with lower-tier subcontractors authorize and direct such parties to participate in the dispute resolution procedures set forth in this Section. Unless otherwise directed in writing by PWC, Contractor shall continue the Work and maintain compliance with the scheduling deadlines set forth in the Contract Documents during any dispute resolution proceedings. If Contractor continues to perform, PWC shall make payments due for the continued performance in accordance with this Agreement. The provisions of this Section shall not extend any applicable statutes of limitation or repose.

21. Execution; Modification; Entire Agreement; Severability. This Agreement may be executed in counterparts with the same effect as if the signatures to each counterpart were upon a single instrument, and all such counterparts together shall be deemed an original of this Agreement. For purposes of this Agreement, a facsimile copy or scanned copy or photocopy of a party's signature shall be sufficient to bind such party. This Agreement shall be subject to execution by electronic means in accordance with Article 40 of Chapter 66 of the North Carolina General Statutes. No oral communication, promise, understanding, or agreement before, contemporaneous with, or after the execution of this Agreement shall affect or modify any of the terms and conditions and obligations of the Contract Documents. The Contract Documents shall be modified only by a subsequent writing signed by both Parties. The Contract Documents shall be conclusively considered to contain and express all the terms and conditions agreed upon by the Parties, notwithstanding any prior or contemporaneous written communication, promise, understanding or agreement. Should any provision of this Agreement or any of the Contract Documents at any time be in conflict with any law, statute, rule, regulation, order, or ruling and thus be unenforceable, or be unenforceable for any other reason, then the remaining provisions of this Agreement shall remain in full force and effect and the court or arbitrator shall give the offending provision the fullest meaning and effect permitted by law. The titles of the Sections throughout this Agreement are for convenience only and the words contained therein shall in no way be held to explain, modify, amplify or aid in the interpretation, construction, or meaning of the provisions of this instrument.

22. Notices. Any notice which either Party is required or desires to give the other hereunder shall be deemed sufficiently given if, in writing, it is delivered personally, or sent by certified U.S. mail, return-receipt requested, postage prepaid, to the addresses listed herein below, or such other address as either Party shall give to the other Party by written notice in accordance herewith. Any notice given herein by personal delivery shall be deemed delivered when received. Any properly addressed notice given herein by certified mail shall be deemed delivered on third Business Day after the same is deposited in an official United States Post Office, postage prepaid, or if sooner upon the date when the return receipt therefore is signed, or refusal to accept the mailing by the addressee is noted thereon by the postal authorities.

To PWC:
Fayetteville Public Works Commission
Attn: Timothy Bryant, CEO/General Manager
PO Box 1089
Fayetteville, NC 28302

To Contractor:

23. Termination. In addition to any other termination rights of PWC set forth in this Agreement, PWC may terminate this Agreement immediately if during the progress of any Authorized Work or during any warranty period, Contractor:

- a. Persistently fails to prosecute Authorized Work properly and in accordance with this Contract, including but not limited to include failure to provide sufficient crews, equipment, or resources, or failure to adhere to the schedule;
- b. Demonstrates disregard for the policies, procedures, or requirements of PWC;
- c. Demonstrates complete disregard of the authority of PWC or its designated representatives; or
- d. Violates in any substantial way the provisions and requirements of this Agreement.

Such termination shall be effective upon written notice to Contractor and its surety. PWC may terminate the contract for its convenience by providing Contractor at least seven (7) calendar days prior written notice, in which event Contractor shall be paid for all Authorized Work completed, plus other expenses as mutually agreed upon between PWC and Contractor.

24. Compliance with North Carolina and Federal Law. Contractor hereby acknowledges that "E-Verify" is the federal E-Verify program operated by the US Department of Homeland Security and other federal agencies which is used to verify the work authorization of newly hired employees pursuant to federal law and in accordance with Article 2, Chapter 64 of the North Carolina General Statutes. Contractor further acknowledges that all employers, as defined by Article 2, Chapter 64 of the North Carolina General Statutes, must use E-Verify and after hiring an employee to work in the United States, shall verify the work authorization of the employee through E-Verify in accordance with N.C.G.S. §64-26(a). Contractor hereby pledges, attests, and warrants through execution of this Agreement that Contractor complies with the requirements of Article 2, Chapter 64 of the North Carolina General Statutes and further pledges, attests, and warrants that all subcontractors currently employed by or subsequently hired by Contractor shall comply with all E-Verify requirements. Failure to comply with the above requirements shall be considered a breach of this Agreement. Contractor hereby further acknowledges that the execution and delivery of this Agreement constitutes Contractor's certification to PWC and to the North Carolina State Treasurer that, as of the date of the Effective Date of this Agreement, Contractor is not listed on (a) the Final Divestment List created and maintained by the North Carolina Department of State Treasurer pursuant to the Iran Divestment Act of 2015, Chapter 147, Article 6E of the General Statutes of North Carolina (the "Iran Divestment Act"); or (b) the list of companies that the North Carolina State Treasurer determines to be engaged in a boycott of Israel in accordance with Article 6G of Chapter 147 of the General Statutes of North Carolina. Contractor represents and warrants to Commission that Contractor, and all persons and entities owning (directly or indirectly) an ownership interest in it: (i) are not, and will not become, a person or entity with whom a party is restricted from doing business with under regulations of the Office of Foreign Asset Control ("OFAC") of the Department of the Treasury (including, but not limited to, those named on OFAC's Specially Designated and Blocked Persons list) or under any statute, executive order (including, but not limited to, the September 24, 2001, Executive Order 13224 Blocking Property and Prohibiting Transactions with Persons Who Commit, Threaten to Commit, or Support Terrorism), or other governmental action; and (ii) are not knowingly engaged in, and will not knowingly engage in,

any dealings or transactions or be otherwise associated with such persons or entities described in clause (i) above. Contractor also shall at all times during the term of this Agreement comply with Executive Order 11246, , as amended by Executive Order 11375, "Amending Executive Order 11246 Relating to Equal Employment Opportunity," and implementing regulations at 41 CFR part 60, "Office of Federal Contract Compliance Programs, Equal Employment Opportunity, Department of Labor," including but not limited to the Equal Opportunity Clause requirements set forth in 41 C.F.R. § 60-1.4. Contractor shall abide by the requirements of 41 CFR 60-300.5(a) and 60-741.5(a) prohibiting discrimination against qualified individuals on the basis of protected veteran status or disability and requiring affirmative action by covered prime contractors and subcontractors to employ and advance in employment qualified protected veterans and individuals with disabilities.

IN WITNESS WHEREOF, the Parties have executed this Agreement by their duly authorized representatives as of the Effective Date.

Fayetteville Public Works Commission

[CONTRACTOR]

By: _____
Timothy Bryant, CEO/GM

By: _____

(Printed Name, Title)

Date: _____

Date: _____

This instrument has been preaudited in the manner required by the Local Government Budget and Fiscal Control Act (N.C. Gen. Stat. § 159-1 et seq.).

By: _____
Rhonda Haskins, Chief Financial Officer

Approved as to form:

Legal Dept.

EXHIBIT A

Hourly Rates

SAMPLE



GENERAL CONDITIONS FOR
FAYETTEVILLE PUBLIC WORKS COMMISSION

General Conditions	5
Article I. Definitions and Terminology	5
Section 1.01 Definitions.....	5
Section 1.02 Terminology.....	9
Article II. Preliminary Matters	10
Section 2.01 Delivery of Bonds and Evidence of Insurance.....	10
Section 2.02 Copies of Documents.....	10
Section 2.03 Before Starting any Work.....	10
Section 2.04 Preconstruction Conference; Designation of Authorized Representatives.....	10
Section 2.05 Initial Acceptance of Schedules.....	11
Section 2.06 Electronic Transmittals.....	11
Article III. Contract Documents: Intent, Requirements, Reuse	12
Section 3.01 Intent.....	12
Section 3.02 Reference Standards.....	12
Section 3.03 Reporting and Resolving Discrepancies.....	12
Section 3.04 Reuse of Documents.....	13
Article IV. Commencement and Progress of the Work	13
Section 4.01 Commencement of Work.....	13
Section 4.02 Reference Points.....	14
Section 4.03 Progress Schedule.....	14
Section 4.04 Delays in Contractor’s Progress.....	14
Article V. Availability of Lands; Subsurface and Physical Conditions; Hazardous Environmental Conditions	15
Section 5.01 Availability of Lands.....	15
Section 5.02 Use of Site and Other Areas.....	15
Section 5.03 Differing Subsurface or Physical Conditions or Underground Facilities.....	16
Section 5.04 Underground Utilities.....	17
Section 5.05 Hazardous Environmental Conditions at Site.....	19
Article VI. Bonds and Insurance	20
Section 6.01 Performance and Payment Bonds.....	20
Section 6.02 Insurance.....	20
Article VII. Contractor’s Responsibilities	22
Section 7.01 Supervision and Superintendence.....	22
Section 7.02 Labor; Working Hours.....	23
Section 7.03 Services, Materials, and Equipment.....	23
Section 7.04 “Or Equals”.....	23
Section 7.05 Concerning Subcontractors, Suppliers, and Others.....	24
Section 7.06 Patent Fees and Royalties.....	25

General Conditions (Rev 7/2023)

Section 7.07	Permits	25
Section 7.08	Taxes	26
Section 7.09	Laws and Regulations	26
Section 7.10	Record Documents	26
Section 7.11	Safety and Protection	26
Section 7.12	Emergencies.....	27
Section 7.13	Shop Drawings, Samples, and Other Submittals	27
Section 7.14	Contractor's General Warranty and Guarantee.....	29
Section 7.15	Indemnification	30
Section 7.16	Claims Procedure	31
Section 7.17	Delegation of Professional Design Services	31
Article VIII.	PWC's Responsibilities	32
Article IX.	Amending the Contract Documents; Changes in the Work.....	32
Section 9.01	Amending and Supplementing Contract Documents.....	33
Section 9.02	PWC-Authorized Changes in the Work.....	33
Section 9.03	Unauthorized Changes in the Work	33
Section 9.04	Change of Contract Price.....	34
Section 9.05	Change of Contract Times	34
Section 9.06	Change Proposals	34
Section 9.07	Execution of Change Orders.....	35
Section 9.08	Notification to Surety.....	35
Article X.	Tests, Inspections, and Approvals; Correction, Removal, or Acceptance of Defective Work.....	35
Section 10.01	Access to Work	35
Section 10.02	Tests, Inspections, and Approvals.....	36
Section 10.03	Defective Work.....	36
Section 10.04	Acceptance of Defective Work	37
Section 10.05	Uncovering Work.....	37
Section 10.06	PWC May Stop the Work	38
Section 10.07	PWC May Correct Defective Work	38
Article XI.	Claims.....	39
Section 11.01	Claims Process	39
Section 11.02	Submittal of Claim	39
Section 11.03	Review and Resolution.....	39
Section 11.04	Dispute Resolution.....	39
Article XII.	Payments to Contractor; Set-Offs; Completion; Correction Period.....	40
Section 12.01	Progress Payments.....	40
Section 12.02	Substantial Completion	43

General Conditions (Rev 7/2023)

Section 12.03	Partial Use or Occupancy	44
Section 12.04	Final Inspection	44
Section 12.05	Final Payment	44
Section 12.06	Waiver of Claims	45
Section 12.07	Correction Period	45
Article XIII.	Suspension of Work and Termination	46
Section 13.01	PWC May Suspend Work	46
Section 13.02	PWC May Terminate for Cause	46
Section 13.03	PWC May Terminate For Convenience	47
Section 13.04	Contractor May Stop Work or Terminate	48
Section 13.05	Morality	48
Article XIV.	Miscellaneous	48
Section 14.01	Additional General Terms and Conditions	48
Section 14.02	Giving Notice	48
Section 14.03	Computation of Times	49
Section 14.04	Cumulative Remedies	49
Section 14.05	Limitation of Damages	49
Section 14.06	No Waiver	49
Section 14.07	Survival of Obligations	49
Section 14.08	Controlling Law	49
Section 14.09	Headings	49

General Conditions

Article I. Definitions and Terminology

Section 1.01 Definitions

Capitalized terms used in the Bid Documents or Contract Documents, including the singular and plural forms, shall have the meaning indicated in the definitions below. In addition to terms specifically defined below, terms with initial capital letters in the Contract Documents include references to identified articles and paragraphs, and the titles of other documents or forms.

- (a) **Addenda**—Written or graphic instruments issued before the opening of Bids which clarify, correct, or change the Bid Documents or other Contract Documents.
- (b) **Agreement**—The written instrument, executed by PWC and Contractor, that sets forth the Contract Price and Contract Times, identifies the parties, designates the specific documents that encompass the Contract Documents, and provides other material provisions that govern the relationship between the parties as it relates to the Project. The Agreement is also referred to, and titled as, the “Construction Agreement.”
- (c) **Application for Payment**—The form that Contractor shall use during the Work in requesting progress or final payments. Any Application for Payment shall be accompanied by such supporting documentation as is required by the Contract Documents.
- (d) **Bid**—The offer of a Bidder submitted on the prescribed form setting forth the prices for the Work to be performed.
- (e) **Bidder**—An individual or entity that submits a Bid to PWC for the Project.
- (f) **Bid Documents**—The Bidding Requirements, the proposed Contract Documents, and all Addenda.
- (g) **Bidding Requirements**—The Invitation to Bid, Instructions to Bidders, Bid Bond or other Bid security, if any, the Bid Form, and the Bidder’s original Bid with any requisite attachments.
- (h) **Business Day**—each calendar day that is not a Saturday, Sunday, or holiday observed by PWC (New Year’s Day, Martin Luther King, Jr. Day, Good Friday, Memorial Day, Independence Day, Labor Day, Veteran’s Day, Thanksgiving Day (and the day after), and Christmas (2 days) for its employees.
- (i) **Change Order**—A document that is signed by Contractor and PWC, which authorizes an addition, deletion, or revision in the Work, an adjustment in the Contract Price or the Contract Times, a change in the scope of the Project, or other revision to the Agreement, issued on or after the Effective Date of the Agreement.
- (j) **Change Proposal**—A written request by Contractor, submitted in compliance with the procedural requirements set forth in the Contract Documents, seeking an adjustment in Contract Price or Contract Times, or both; contesting an initial decision by PWC concerning the requirements of the Contract Documents or the acceptability of Work under the Contract Documents; challenging a set-off against payments due; or seeking other relief with respect to the terms of the Agreement.

- (k) Completion of the Project—Has the meaning as set forth in the Construction Agreement.
- (l) Constituent of Concern—Asbestos, petroleum, radioactive materials, polychlorinated biphenyls (PCBs), hazardous waste, and any substance, product, waste, or other material of any nature whatsoever that is or becomes listed, regulated, or addressed pursuant to (a) the Comprehensive Environmental Response, Compensation and Liability Act, 42 U.S.C. §§9601 et seq. (“CERCLA”); (b) the Hazardous Materials Transportation Act, 49 U.S.C. §§5101 et seq.; (c) the Resource Conservation and Recovery Act, 42 U.S.C. §§6901 et seq. (“RCRA”); (d) the Toxic Substances Control Act, 15 U.S.C. §§2601 et seq.; (e) the Clean Water Act, 33 U.S.C. §§1251 et seq.; (f) the Clean Air Act, 42 U.S.C. §§7401 et seq.; or (g) any other federal, state, or local statute, law, rule, regulation, ordinance, resolution, code, order, or decree regulating, relating to, or imposing liability or standards of conduct concerning, any hazardous, toxic, or dangerous waste, substance, or material.
- (m) Contract Price—The money that PWC has agreed to pay Contractor for Completion of the Project in accordance with the Contract Documents. May also be referred to as “Price” throughout the Contract Documents.
- (n) Contract Times—The number of days or the dates by which Contractor shall: (a) achieve Milestones, if any; and (b) Completion of the Project.
- (o) Contractor—The individual or entity with which PWC has contracted for performance of the Work and Completion of the Project.
- (p) Day—a calendar day of 24 hours measured from midnight to the next midnight. Also referred to throughout the Contract Documents as “days” or “calendar days.”
- (q) Design Engineer—The Engineering firm identified on the Contract Drawings and their duly authorized employees and agents, such employees and agents acting within the scope of the particular duties entrusted to them in each case.
- (r) Drawings—The part of the Contract that graphically shows the scope, extent, and character of the Work to be performed by Contractor.
- (s) Field Order—A written order issued by Project Engineer which requires minor changes in the Work but does not change the Contract Price or the Contract Times.
- (t) Final Completion—The day the on which any specified Work is complete in accordance with the Contract Documents.
- (u) Hazardous Environmental Condition—The presence at the Site of Constituents of Concern in such quantities or circumstances that may present a danger to persons or property exposed thereto. The presence at the Site of materials that are necessary for the execution of the Work, or that are to be incorporated in the Work, and that are controlled and contained pursuant to industry practices, Laws and Regulations, and the requirements of the Contract Documents, does not establish a Hazardous Environmental Condition.
- (v) Laws and Regulations; Laws or Regulations—Any and all applicable laws, statutes, rules,

General Conditions (Rev 7/2023)

regulations, ordinances, codes, and orders of any and all governmental bodies, agencies, authorities, and courts having jurisdiction. Such terms, unless otherwise specified, shall refer to North Carolina laws and regulations.

- (w) Milestone—A principal event in the performance of the Work that the Agreement requires Contractor to achieve by an intermediate completion date or by a time prior to Completion of the Project.
- (x) Non-Compliance Notice—A written notice issued by PWC to Contractor indicating a violation of any term, provision, or requirement of the Contract Documents.
- (y) Notice of Award—The written notice by PWC to a Bidder providing of PWC's acceptance of the Bid upon timely compliance by the Bidder with any conditions precedent provided in the notice.
- (z) Notice to Proceed—A written notice by PWC to Contractor fixing the date on which the Contract Times will commence to run and on which Contractor shall start to perform the Work.
- (aa) Progress Schedule—A schedule, prepared and maintained by Contractor, describing the sequence and duration of the activities comprising the Contractor's plan to accomplish the Work within the Contract Times.
- (bb) Project—has the meaning ascribed to it in the Agreement and is as more specifically set forth throughout the Contract Documents. "Project" includes the total undertaking to be accomplished for PWC by engineers, contractors, and others, including planning, study, design, construction, testing, commissioning, and start-up, and of which the Work to be performed under the Contract Documents is a part.
- (cc) Project Engineer—the PWC employee assigned by PWC to coordinate, manage, monitor, and otherwise perform the administration necessary and consistent with PWC's responsibilities for the Completion of the Project. The Project Engineer has authority to coordinate and work with the Design Engineer regarding any engineering questions, concerns, revisions, alterations, deletions, or additions to the Work, and has authority to approve any changes in the scope of the Work. Project Engineer may assign a "Project Coordinator" who will also be an employee of PWC and have the duties and responsibilities set by the Project Engineer.
- (dd) PWC—Fayetteville Public Works Commission. PWC may also be referred to in the Contract Documents as "Owner."
- (ee) Samples—Physical examples of materials, equipment, or workmanship that are representative of some portion of the Work and that establish the standards by which such portion of the Work will be judged.
- (ff) Schedule of Submittals—A schedule, prepared and maintained by Contractor, of required submittals and the time requirements for Project Engineer's review of the submittals and the performance of related construction activities.
- (gg) Schedule of Values—A schedule, prepared and maintained by Contractor, allocating portions of the Contract Price to various portions of the Work and used as the basis for reviewing Contractor's Applications for Payment.

General Conditions (Rev 7/2023)

- (hh) Shop Drawings—All drawings, diagrams, illustrations, schedules, and other data or information that are specifically prepared or assembled by or for Contractor and submitted by Contractor to illustrate some portion of the Work. Shop Drawings, whether approved or not, are not Contract Drawings and are not Contract Documents.
- (ii) Site—Lands or areas indicated in the Contract Documents as being furnished by PWC upon which the Work is to be performed, including rights-of-way and easements, and such other lands furnished by PWC which are designated for the use of Contractor.
- (jj) Specifications—The part of the Contract that consists of written requirements for materials, equipment, systems, standards, and workmanship as applied to the Work, and certain administrative requirements and procedural matters applicable to the Work.
- (kk) Subcontractor—An individual or entity having a direct contract with Contractor or with any other Subcontractor for the performance of a part of the Work.
- (ll) Substantial Completion—The time at which the Work (or a specified part thereof) has progressed to the point where, in the opinion of Project Engineer, the Work (or a specified part thereof) is sufficiently complete, in accordance with the Contract Documents, so that the Work (or a specified part thereof) can be utilized for the purposes for which it is intended. The terms “substantially complete” and “substantially completed” as applied to all or part of the Work refer to Substantial Completion thereof.
- (mm) Successful Bidder—The Bidder whose Bid PWC accepts, and to which PWC provides a Notice of Award.
- (nn) Supplementary Conditions—Any part of the Agreement that amends or supplements these General Conditions.
- (oo) Supplier—A manufacturer, fabricator, supplier, distributor, materialman, or vendor having a direct contract with Contractor or with any Subcontractor to furnish materials or equipment to be incorporated in the Work by Contractor or a Subcontractor.
- (pp) Technical Data—Those items expressly identified as Technical Data in the Supplementary Conditions, with respect to either (a) subsurface conditions at the Site, or physical conditions relating to existing surface or subsurface structures at the Site (except Underground Facilities) or (b) Hazardous Environmental Conditions at the Site. If no such express identifications of Technical Data have been made with respect to conditions at the Site, then the data contained in boring logs, recorded measurements of subsurface water levels, laboratory test results, and other factual, objective information regarding conditions at the Site that are set forth in any geotechnical or environmental report prepared for the Project and made available to Contractor are hereby defined as Technical Data with respect to conditions at the Site under Paragraphs 5.03, 5.04, and 5.06.
- (qq) Underground Facilities—All underground pipelines, conduits, ducts, cables, wires, manholes, vaults, tanks, tunnels, or other such facilities or attachments, and any encasements containing such facilities, including but not limited to those that convey electricity, gases, steam, liquid petroleum products, telephone or other communications, fiber optic transmissions, cable television, water, wastewater, storm water, other liquids or chemicals, or traffic or other control systems.

General Conditions (Rev 7/2023)

- (rr) Unit Price Work—Work to be paid for on the basis of unit prices.
- (ss) Work—The entire construction or the various separately identifiable parts thereof required to be provided under the Contract Documents. Work includes and is the result of performing or providing all labor, services, materials, equipment, and documentation necessary to produce such construction; furnishing, installing, and incorporating all materials and equipment into such construction; and may include related services such as testing, start-up, and commissioning, all as required by the Contract Documents and necessary to achieve Completion of the Project.
- (tt) Work Change Directive—A written directive to Contractor issued on or after the Effective Date of the Contract, signed by PWC and recommended by the Project Engineer, ordering an addition, deletion, or revision in the Work.

Section 1.02 Terminology

The words and terms discussed in the following paragraphs are not defined but, when used in the Bidding Requirements or Contract Documents, have the indicated meaning.

- (a) Intent of Certain Terms or Adjectives:
 - (i) The Contract Documents include the terms “as allowed,” “as approved,” “as ordered,” “as directed” or terms of like effect or import to authorize an exercise of professional judgment by Project Engineer. In addition, the adjectives “reasonable,” “suitable,” “acceptable,” “proper,” “satisfactory,” or adjectives of like effect or import are used to describe an action or determination of Project Engineer as to the Work. It is intended that such exercise of professional judgment, action, or determination will be solely to evaluate, in general, the Work for compliance with the information in the Contract Documents and with the design concept of the Project as a functioning whole as shown or indicated in the Contract Documents (unless there is a specific statement indicating otherwise). The use of any such term or adjective is not intended to and shall not be effective to assign to Project Engineer any duty or authority to supervise or direct the performance of the Work, or any duty or authority to undertake responsibility contrary to the provisions the Contract Documents.
- (b) Defective—when modifying the word “Work,” refers to Work that is unsatisfactory, faulty, or deficient in that it:
 - (i) does not conform to the Contract Documents; or
 - (ii) does not meet the requirements of any applicable inspection, reference standard, test, or approval referred to in the Contract Documents; or
 - (iii) has been damaged prior to Project Engineer’s recommendation of final payment (unless responsibility for the protection thereof has been assumed by PWC at Substantial Completion in accordance with the Contract Documents).
- (c) Furnish, Install, Perform, Provide
 - (i) The word “furnish,” when used in connection with services, materials, or equipment, shall mean to supply and deliver said services, materials, or equipment to the Site (or some other specified location) ready for use or installation and in usable or operable condition.
 - (ii) The word “install,” when used in connection with services, materials, or equipment, shall mean to put into use or place in final position said services, materials, or equipment

General Conditions (Rev 7/2023)

- complete and ready for intended use.
- (iii) The words “perform” or “provide,” when used in connection with services, materials, or equipment, shall mean to furnish and install said services, materials, or equipment complete and ready for intended use.
- (iv) If the Contract Documents establish an obligation of Contractor with respect to specific services, materials, or equipment, but do not expressly use any of the four words “furnish,” “install,” “perform,” or “provide,” then Contractor shall furnish and install said services, materials, or equipment complete and ready for intended use.

Unless stated otherwise in the Contract Documents, words or phrases that have a well-known technical or construction industry or trade meaning are used in the Contract Documents in accordance with such recognized meaning.

Article II. Preliminary Matters

Section 2.01 Delivery of Bonds and Evidence of Insurance

- (a) Bonds: Contractor shall deliver to PWC such bonds as Contractor is required to furnish simultaneously with delivering the executed Agreement to PWC.
- (b) Contractor’s Insurance: Contractor shall deliver to PWC the certificates and other evidence of the insurance required by the Contract Documents simultaneously with delivering the executed Agreement to PWC.

Section 2.02 Copies of Documents

- (a) PWC will furnish to Contractor up to five (5) printed copies of the Contract Documents upon request by Contractor, and one (1) copy in electronic portable document format (PDF). Additional printed copies will be furnished upon request at the cost of reproduction.
- (b) PWC will maintain and safeguard at least one original printed record version of the Agreement, including Drawings and Specifications signed and sealed by Design Engineer or other design professionals as applicable. PWC agrees to make such original printed record version of the Agreement reasonably available to Contractor for review during PWC’s normal business hours. PWC may delegate the responsibilities under this provision to Design Engineer.

Section 2.03 Before Starting any Work

- (a) Within ten (10) Days after the Contractor receives the Notice of Award from PWC (or as otherwise specifically required by the Contract Documents), Contractor shall submit to PWC for timely review:
 - (i) a preliminary Progress Schedule indicating the times (numbers of days or dates) for starting and completing the identifiable aspects of the Work, including any Milestones specified in the Contract Documents;
 - (ii) a preliminary Schedule of Submittals; and
 - (iii) Any Shop Drawings, Samples, and other submittals required by the Contract Documents before the Preconstruction Conference.

Section 2.04 Preconstruction Conference; Designation of Authorized Representatives

- (a) Before any Work at the Site is started, a preconstruction conference attended by PWC, Project Engineer, Contractor, Design Engineer, and others as appropriate will be held to establish a working understanding among the parties as to the Work and to discuss general Project issues including, but not limited, the following:
 - (i) The schedules and submittals referred to in Section 2.03;
 - (ii) Contractor's designated authorized representative as described in Section 2.04(b);
 - (iii) Safety;
 - (iv) Procedures for handling Shop Drawings, Samples, and other submittals;
 - (v) Processing Applications for Payment, electronic or digital transmittals;
- (b) At the preconstruction conference Contractor shall designate, in writing, a specific individual to act as its authorized representative with respect to its services and responsibilities under the Contract Documents. Such individual shall have the authority to transmit and receive information, render decisions relative to the requirements of the Contract Documents, and otherwise act on behalf of the Contractor.

Section 2.05 Initial Acceptance of Schedules

- (a) At least twenty (20) Days before submission of the first Application for Payment a conference, attended by Contractor, PWC, and others as appropriate, will be held to review for acceptability to Project Engineer as provided below the schedules submitted in accordance with Paragraph 2.03(a). PWC shall have ten (10) Days to review the submission and provide feedback to Contractor. Contractor shall then have ten (10) days to make any corrections and adjustments as indicated by PWC and to complete and resubmit the schedules as necessary. No progress payment shall be made to Contractor until acceptable schedules are submitted to and approved by Project Engineer.
- (b) The Progress Schedule will be acceptable to Project Engineer if it provides an orderly progression of the Work to achieve Completion of the Project within the Contract Times. Such acceptance will not impose on Project Engineer responsibility for the Progress Schedule, for sequencing, scheduling, or progress of the Work, nor interfere with or relieve Contractor from Contractor's full responsibility therefor.
- (c) Contractor's Schedule of Submittals will be acceptable to Project Engineer if it provides a workable arrangement for reviewing and processing the required submittals.

Section 2.06 Electronic Transmittals

- (a) Except as otherwise stated elsewhere in the Contract Documents, PWC and Contractor and their authorized agents may transmit, and shall accept, Project-related correspondence, text, data, documents, drawings, information, and graphics, including but not limited to Shop Drawings and other submittals, in electronic media or digital format, either directly, or through electronic mail at the address(es) designated by each Party.
- (b) When transmitting items in electronic media or digital format, the transmitting party makes no representations as to long term compatibility, usability, or readability of the items resulting from the recipient's use of software application packages, operating systems, or computer hardware differing from those used in the drafting or transmittal of the items, or from those established in applicable transmittal protocols.

Article III. Contract Documents: Intent, Requirements, Reuse

Section 3.01 Intent

- (a) The Contract Documents are complementary; what is required by one is as binding as if required by all.
- (b) It is the intent of the Contract Documents to describe a functionally complete project (or part thereof) to be constructed in accordance with the Contract Documents.
- (c) Project Engineer, Design Engineer, or both, will issue clarifications and interpretations of the Contract Documents as provided herein.
- (d) To the extent necessary that Work, construction, or conditions not covered by these General Conditions is required for Contractor to achieve Completion of the Project, "Special Conditions" for such Work will be provided to Contractor and shall be part of the Contract Documents.
- (e) In case of any inconsistency, conflict, or ambiguity among the Contract Documents, the documents shall govern in the following order: (1) Change Orders; (2) Addenda; (3) the fully executed Agreement; (4) Special Conditions; (5) any Drawings and Technical Specifications; and (6) General Conditions.

Section 3.02 Reference Standards

- (a) Standards Specifications, Codes, Laws and Regulations
 - (i) Reference in the Contract Documents to standard specifications, manuals, reference standards, or codes of any technical society, organization, or association, or to Laws or Regulations, whether such reference be specific or by implication, shall mean the standard specification, manual, reference standard, code, or North Carolina laws and regulations in effect as of the Effective Date of the Agreement, except as may be otherwise specifically stated in the Contract Documents.
 - (ii) No provision of any such standard specification, manual, reference standard, or code, or any instruction of a Supplier shall be effective to change the duties or responsibilities of PWC or Contractor, or any of their subcontractors, consultants, agents, or employees, from those set forth in the Contract Documents. No such provision or instruction shall be effective to assign to PWC or any of its officers, directors, members, partners, employees, agents, consultants, or subcontractors, any duty or authority to supervise or direct the performance of the Work or any duty or authority to undertake responsibility inconsistent with the provisions of the part of the Contract Documents.

Section 3.03 Reporting and Resolving Discrepancies

- (a) Contractor's Verification of Figures and Measurements
 - (i) Before undertaking any portion of the Work, Contractor shall review all of the Contract Documents to and check and verify all figures and dimensions for the Project. Contractor shall promptly report in writing to Project Engineer any conflict, error, ambiguity, or discrepancy that Contractor discovers, or has actual knowledge of, and shall not proceed with any Work affected thereby until the conflict, error, ambiguity, or discrepancy is

General Conditions (Rev 7/2023)

resolved, by a clarification or interpretation by Project Engineer, or by an amendment or supplement to the Contract Documents issued pursuant to these General Conditions.

- (ii) If, before or during the performance of the Work, Contractor discovers any conflict, error, ambiguity, or discrepancy within the Contract Documents, or between the Contract Documents and (a) any applicable Law or Regulation, (b) actual field conditions, (c) any standard specification, manual, reference standard, or code, or (d) any instruction of any Supplier, then Contractor shall promptly report it to Project Engineer in writing. Contractor shall not proceed with the Work affected thereby (except in an emergency as defined hereinafter) until the conflict, error, ambiguity, or discrepancy is resolved, by a clarification or interpretation by Project Engineer, or by an amendment or supplement to the Contract Documents issued pursuant to these General Conditions.

(b) Resolving Discrepancies:

- (i) Except as may be otherwise specifically stated in the Contract Documents, the provisions of the part of the Contract Documents prepared by or for PWC shall take precedence in resolving any conflict, error, ambiguity, or discrepancy between such provisions of the Contract Documents and:
 - 1) the provisions of any standard specification, manual, reference standard, or code, or the instruction of any Supplier (whether or not specifically incorporated by reference as a Contract Document); or
 - 2) the provisions of any Laws or Regulations applicable to the performance of the Work (unless such an interpretation of the provisions of the Contract Documents would result in violation of such Law or Regulation).

Section 3.04 Reuse of Documents

- (a) Contractor and its Subcontractors and Suppliers shall not have or acquire any title to or ownership rights in any of the:
 - (i) Drawings, Specifications, or other documents (or copies of any thereof) prepared by or bearing the seal of Design Engineer or its consultants, including electronic media editions, or reuse any such Drawings, Specifications, other documents, or copies thereof on extensions of the Project or any other project without written consent of PWC and Design Engineer and specific written verification or adaptation by Design Engineer, where applicable; or
 - (ii) Contract Documents and shall not reuse any such Contract Documents for any purpose without PWC's express written consent.
- (b) The prohibitions of this provision shall survive final payment or termination of the Agreement. Nothing herein shall preclude Contractor from retaining copies of the Contract Documents for record purposes.

Article IV. Commencement and Progress of the Work

Section 4.01 Commencement of Work

- (a) The Contract Times will commence to run on the day indicated in the Notice to Proceed issued by PWC to Contractor. A Notice to Proceed may be given at any time after the Effective Date of the Contract.

- (b) Contractor shall start to perform the Work on the date when the Contract Times commence to run. No Work shall be done at the Site prior to such date. Contractor's failure to commence the Work within fifteen (15) Days of the date stated in the Notice to Proceed shall be deemed a material breach of the Agreement unless PWC otherwise determines in its sole discretion and agrees in writing to a delay of the Contract Times based on the applicable circumstances.

Section 4.02 Reference Points

- (a) Construction staking will be performed by Design Engineer, who will also prepare and furnish construction cut sheets, signed and sealed by a North Carolina professional land surveyor, to PWC and Contractor. Contractor shall not install any utilities without a sheet. All requests for staking shall be made not less than 96 hours in advance.
- (b) Contractor shall be responsible for laying out the Work, shall protect and preserve the established reference points and staking, and shall make no changes or relocations without the prior written approval of Project Engineer. Contractor shall report to Project Engineer whenever any reference point staking is lost or destroyed or requires relocation because of necessary changes in grades or locations, and shall be responsible for the accurate replacement or relocation of such reference points or staking by professionally qualified personnel.

Section 4.03 Progress Schedule

- (a) Contractor shall adhere to the Progress Schedule established in accordance with Section 2.03 as it may be adjusted from time-to-time as provided below. Contractor shall submit to Project Engineer for acceptance any proposed adjustments in the Progress Schedule that will not result in changing the Contract Times. Proposed adjustments in the Progress Schedule that will change the Contract Times shall be submitted in accordance with the requirements of Article IX.
- (b) Contractor shall carry on the Work and adhere to the Progress Schedule during any disputes or disagreements with PWC. No Work shall be delayed or postponed pending resolution of any disputes or disagreements, or during any appeal process, except as permitted by these General Conditions or as PWC and Contractor may otherwise agree in writing.

Section 4.04 Delays in Contractor's Progress

- (a) If PWC, Project Engineer, anyone for whom PWC is responsible, or a Force Majeure Event delays, disrupts, or interferes with the performance or progress of the Work, then Contractor shall be entitled to an equitable adjustment in the Contract Times and Contract Price. Contractor's entitlement to an adjustment of the Contract Times is conditioned on such adjustment being essential to Contractor's ability to complete the Work within the Contract Times.
- (b) Contractor shall not be entitled to an adjustment in Contract Price or Contract Times for delay, disruption, or interference caused by or within the control of Contractor. Delay, disruption, and interference attributable to and within the control of a Subcontractor or Supplier shall be deemed to be within the control of Contractor.

- (c) Contractor must submit any Change Proposal, consistent with the procedure set forth in Article IX, seeking an adjustment in Contract Price or Contract Times under this provision within ten (10) calendar days of the commencement of the event that causes the delay, disruption, or interference with the Work and Contract Times.

Article V. Availability of Lands; Subsurface and Physical Conditions; Hazardous Environmental Conditions

Section 5.01 Availability of Lands

- (a) PWC will be responsible for obtaining any required easements and encroachments, and otherwise furnishing the Site, necessary to complete the Work, except as provided elsewhere in the Contract Documents.
- (b) Upon reasonable written request, PWC shall furnish to Contractor a current statement of record legal title and legal description of the lands upon which the Work is to be completed and PWC's interest therein.
- (c) Contractor shall provide for all additional lands and access thereto that may be required for temporary construction facilities or storage of materials and equipment necessary to complete the Work. Any and all agreements between the Contractor and any individual property owner(s) shall not obligate PWC, PWC's employees, Project Engineer, or Design Engineer in any manner, and Contractor shall, before performing any work on any such property, obtain a signed and notarized release of liability of PWC and Design Engineer that is suitable to PWC as confirmed in writing.
- (d) Contractor and any of its Subcontractors shall exercise care and caution to avoid damage to any private property. Should any such damage to private property occur, it is Contractor's responsibility to notify the Project Engineer promptly in writing that such damage occurred, the extent of the damage, and Contractor's written plan to remedy the damage. If Contractor fails to timely correct damage to private property, PWC reserves the right to withhold progress payments until damage is corrected and/or to correct damage and back-charge Contractor for costs incurred. At the Completion of the Project, Contractor shall obtain a signed release from all owners of private property to which damage occurred that releases PWC and Design Engineer and acknowledges a settlement for the damage or that such damage was adequately remedied.

Section 5.02 Use of Site and Other Areas

- (a) Contractor shall confine construction equipment, temporary construction facilities, the storage of materials and equipment, and the operations of workers to the Site and other adjacent areas permitted by Laws and Regulations and shall not unreasonably encumber the Site and such other adjacent areas with construction equipment or other materials or equipment. Contractor shall assume full responsibility for (a) damage to the Site; (b) damage to any such other adjacent areas used for Contractor's operations; (c) damage to any other adjacent land or areas; and (d) for injuries and losses sustained by the owners or occupants of any such land or areas; provided that such damage or injuries result from the performance of the Work or from other actions or conduct of the Contractor or those for which Contractor is responsible.

General Conditions (Rev 7/2023)

- (b) Contractor shall keep the Site and other adjacent areas free from accumulations of waste materials, rubbish, and other debris during the progress of the Work. Removal and disposal of such debris shall conform to applicable Laws and Regulations.
- (c) Prior to Completion of the Project, Contractor shall clean the Site and the Work and make it ready for utilization by PWC. At the completion of all of the Work, Contractor shall remove from the Site and adjacent areas all tools, appliances, construction equipment and machinery, and surplus materials and shall restore to original condition all property not designated for alteration by the Contract Documents.
- (d) Contractor shall not load nor permit any part of any structure to be loaded in any manner that will endanger the structure, nor shall Contractor subject any part of the Work or adjacent structures or land to stresses or pressures that will endanger them.

Section 5.03 Differing Subsurface or Physical Conditions or Underground Facilities

- (a) If Contractor believes that any subsurface or physical condition or Underground Facilities that is uncovered or revealed at the Site either:
 - (i) is of such a nature as to establish that any Technical Data on which Contractor is entitled to rely is materially inaccurate;
 - (ii) is of such a nature as to require a change in the Contract Documents;
 - (iii) differs materially from that shown or indicated in the Contract Documents; or
 - (iv) is of an unusual nature, and differs materially from conditions ordinarily encountered and generally recognized as inherent in work of the character provided for in the Contract Documents;

then Contractor shall, promptly after becoming aware thereof and before further disturbing the subsurface or physical conditions or Underground Facilities or performing any Work in connection therewith, notify PWC and Engineer in writing about such condition. Contractor shall not further disturb such condition or perform any Work in connection therewith (except with respect to an emergency) until receipt of a written statement approved by PWC permitting Contractor to do so.

- (b) After receipt of Contractor's written notice, Project Engineer will review the subsurface or physical condition or Underground Facilities in question; determine the necessity of PWC obtaining additional exploration or tests with respect to the condition; conclude whether the condition falls within any of the differing site condition categories in this Section 5.03; and obtain any pertinent cost or schedule information from Contractor.
- (c) Project Engineer will issue a written statement to Contractor regarding the subsurface or physical condition or Underground Facilities in question, which addresses the resumption of Work in connection with such condition and indicates whether any change in the Contract Documents will be made.
- (d) Possible Price and Times Adjustments:
 - (i) Contractor shall be entitled to an equitable adjustment in Contract Price or Contract Times, or both, to the extent that the existence of a differing subsurface or physical condition or Underground Facilities, or any related delay, disruption, or interference, causes an increase or decrease in Contractor's cost of, or time required for, performance of the Work; subject, however, to the following:

General Conditions (Rev 7/2023)

- 1) such condition must fall within at least one of the categories in this Section 5.03; and,
 - 2) Contractor's entitlement to an adjustment of the Contract Times is conditioned on such adjustment being essential to Contractor's ability to complete the Work within the Contract Times.
- (ii) Contractor shall not be entitled to any adjustment in the Contract Price or Contract Times with respect to a subsurface or physical condition or Underground Facilities if:
- 1) Contractor knew of the existence of such condition at the time Contractor proffered its Bid to PWC or executed the applicable Agreement for the Project; or
 - 2) the existence of such condition reasonably could have been discovered or revealed as a result of any examination, investigation, exploration, test, or study of the Site and contiguous areas expressly required by the Bidding Requirements or Contract Documents to be conducted by or for Contractor prior to Contractor's Bid; or
 - 3) Contractor failed to give the written notice as required.
- (iii) If PWC and Contractor agree regarding Contractor's entitlement to, and the amount or extent of, any adjustment in the Contract Price or Contract Times, or both, then any such adjustment shall be set forth in a Change Order.
- (iv) Contractor may submit a Change Proposal regarding its entitlement to or the amount or extent of any adjustment in the Contract Price or Contract Times, or both, no later than 30 calendar days after Project Engineer's written statement to Contractor regarding the subsurface or physical condition or Underground Facilities in question.

Section 5.04 Underground Utilities

- (a) Contractor shall ascertain the location and type of all underground utility lines or structures that may be located within the limits of the Site or any area where Work is to be performed.
- (i) The exact location of underground utilities or structures may vary from prior plans, permits, maps, or other documentation, and others may not be designated. The Contractor is fully responsible for verification of the exact location of all underground utility lines or structures within the limits of the Site or the area where the work is to be performed, whether known or unknown by PWC, and for providing necessary protection and/or repair if damage.
 - (ii) Should uncharted or incorrectly charted piping or other utilities be encountered during excavations, the Contractor shall immediately halt any Work, notify PWC, and await direction from PWC before proceeding with any Work. The Contractor shall fully cooperate with PWC and any other utility company in keeping respective services and facilities in operation.
- (b) PWC has used reasonable care to locate and depict existing underground installation on the construction drawings, but the accuracy cannot be guaranteed, and some items may not be shown which exist. Actual horizontal and vertical locations have not been verified. As part of the Work, the Contractor is required to dig up each utility which may conflict with construction in advance to verify locations. The utilities shall be "dug up" a minimum of fourteen (14) Days in advance of actual installation of new utilities to allow PWC an opportunity to adjust grades and alignments, to avoid a conflict, and to address

General Conditions (Rev 7/2023)

any other issues.

- (c) The Contractor shall adhere to the provisions of the North Carolina Underground Utility Safety and Damage Prevention Act. The Contractor shall make a documented request to the North Carolina One Call Center, and/or individual utility owners, in order to locate any facilities within the Site limits or any area where Work is to be performed at least forty-eight (48) hours in advance of the day the Work is scheduled to begin. The Contractor shall include the cost of any coordination and cooperation for utilities in its Bid.
- (i) Location assistance requested from PWC by Contractor should include the actual horizontal location, type number, size, and depth of all lines. All costs associated with locating and marking existing utilities or the utilities representatives shall be the responsibility of the Contractor.
- (ii) The Owner, Project Engineer, Design Engineer, and/or Consultants shall not be liable to the Contractor for any claims, costs, losses, or damages incurred or sustained on or in connection with locating existing underground installations.
- (d) If the Contractor fails to schedule locates or perform advance physical locations in advance of the construction and a conflict arises, the Contractor will be required to make corrective measures as instructed by the Project Engineer at the Contractor's expense. The Contractor's failure to advance plan (minimum fourteen (14) days) by physically uncovering existing utilities in advance of construction shall not be cause for claim of lost time or for additional compensation. No additional payment will be made for re-mobilization required by the utility locator.
- (i) The Contractor shall inform all equipment operators, either those employed by him or those employed by his subcontractors, of information obtained from the utility owners prior to initiation of any aspect of any Work.
- (e) PWC and Design Engineer shall not be responsible for the accuracy or completeness of any information or data provided to the Contractor with respect to underground facilities.
- (f) The entire cost of all of the following will be included in the Contract Price, and Contractor shall bear full responsibilities for all such costs, including but not limited to:
 - (i) Reviewing and checking all such information and data;
 - (ii) Locating all underground facilities shown or indicated in the Contract Documents;
 - (iii) Coordination of the Work with the owners of such underground facilities, including PWC, during any portion of the Work; and
 - (iv) The safety and protection of all such underground facilities and repairing any damage thereto resulting from the Work.
- (g) Contractor shall be responsible for the discovery of existing underground installations, in advance of any excavating or trenching as required in the Contract Documents.

General Conditions (Rev 7/2023)

- (h) If an underground facility is discovered at or contiguous to the Site that was not shown or indicated in the Contract Documents or of which Contractor was not aware prior to starting that portion of any Work, Contractor shall, immediately after becoming aware thereof and before further disturbing conditions affected thereby or performing any Work in connection therewith (except in an emergency), identify the owner of such underground facility and give written notice to PWC. Upon receipt of written notice, PWC will review the pertinent condition, determine the necessity of obtaining additional information, and advise Contractor in writing. During such time, Contractor shall be responsible for the safety and protection of such underground facility. If PWC concludes that a change in the Contract Documents is required, a Change Order will be issued.
- (i) The Contract Price and/or the Contract Time, may be adjusted if PWC determines, in its discretion, that the existence of such differing subsurface or physical condition causes an increase or decrease in Contractor's cost of, or time required for, performance of the Work subject to the following:
 - 1) Facility was not shown or indicated in the Contract Documents, and
 - 2) The Contractor did not know of or could not anticipate the facility.

Section 5.05 Hazardous Environmental Conditions at Site

- (a) Contractor shall not be responsible for removing or remediating any Hazardous Environmental Condition encountered, uncovered, or revealed at the Site unless such removal or remediation is expressly identified in the Contract Documents to be within the scope of the Work or Hazardous Environmental Condition was caused by Contractor.
- (b) Contractor shall be responsible for controlling, containing, and removing all Constituents of Concern brought to the Site by Contractor, Subcontractors, Suppliers, or anyone else for whom Contractor is responsible, and for any associated costs; and for the costs of removing and remediating any Hazardous Environmental Condition created by the presence of any such Constituents of Concern.
- (c) If Contractor encounters, uncovers, or reveals a Hazardous Environmental Condition whose removal or remediation is not expressly identified in the Contract Documents as being within the scope of the Work, or if Contractor or anyone for whom Contractor is responsible creates a Hazardous Environmental Condition, then Contractor shall immediately: (1) secure or otherwise isolate such condition; (2) stop all Work in connection with such condition and in any area affected thereby (except in an emergency); and (3) immediately notify Project Engineer (and promptly thereafter confirm such notice in writing). Project Engineer will evaluate such condition or take corrective action, if any. If Contractor or anyone for whom Contractor is responsible created the Hazardous Environmental Condition in question, then PWC may have the Hazardous Environmental Condition removed and remediated and impose a set-off against payments to Contractor to account for the reasonable associated costs.
- (d) Contractor shall not resume Work in connection with such Hazardous Environmental Condition or in any affected area until after PWC has delivered written notice to Contractor either (1) specifying that such condition and any affected area is or has been rendered safe for the resumption of Work, or (2) specifying any special conditions under which such Work may be resumed safely.

General Conditions (Rev 7/2023)

- (e) If PWC and Contractor cannot agree as to entitlement to or on the amount or extent, if any, of any adjustment in Contract Price or Contract Times, or both, as a result of such Work stoppage or such special conditions under which Work is agreed to be resumed by Contractor, then within thirty (30) calendar days of PWC's written notice regarding the resumption of Work, Contractor may submit a Change Proposal or PWC may impose a set-off.
- (f) If after receipt of such written notice Contractor does not agree to resume such Work based on reasonable evidence it is unsafe or does not agree to resume such Work under such special conditions, then PWC may order the portion of the Work that is in the area affected by such condition to be deleted from the Work.

Article VI. Bonds and Insurance

Section 6.01 Performance and Payment Bonds

- (a) Contractor shall obtain and furnish to PWC a performance bond in the amount of one hundred percent (100%) of the Contract Price, conditioned upon the faithful performance of the Project and all Work in accordance with the Contract Documents, which bond shall be solely for the protection of PWC.
- (b) Contractor shall obtain and furnish to PWC a payment bond in the amount of one hundred percent (100%) of the Contract Price, conditioned upon the prompt payment for all labor or materials for which the Contractor or one or more of its subcontractors is liable, which payment bond shall be solely for the protection of the persons furnishing materials or performing labor for which the Contractor is liable.
- (c) The performance bond and the payment bond shall be executed by one or more surety companies legally authorized to do business in the State of North Carolina, shall become effective upon the awarding of the construction contract by PWC to Contractor, and shall at all times comply with the requirements set forth in Article 3 of North Carolina General Statutes Chapter 44A.
- (d) In the event PWC deems the surety or sureties upon any bond necessary for the Agreement and the completion of the Project, or if for any reason, such bond ceases to be adequate to cover the performance and/or payment of the Work, Contractor shall, at its expense, and within ten (10) days after the receipt of notice from PWC, furnish such additional bond(s) in such form and amount, and with such surety or sureties, as shall be satisfactory to PWC. In such event no further payment to Contractor shall be deemed to be due under this Agreement until new or additional security for the performance and payment of the Project shall be furnished in manner and form satisfactory to PWC.
- (e) By executing the Agreement, Contractor understands and acknowledges that PWC, as a public authority, and the City, as a municipal corporation, are not subject to the provisions of Articles 1 and 2 of Chapter 44A of the General Statutes, in accordance with G.S. 44A-34 and applicable law.

Section 6.02 Insurance

- (a) Contractor shall maintain during the life of the Agreement and during the completion of any Work the following insurance coverages, which insurance shall be placed with insurance companies authorized to do business in the State of North Carolina and rate A minus VII or

General Conditions (Rev 7/2023)

better by the current edition of Best's Key Rating Guide or otherwise approved in writing by PWC:

- (i) Commercial general liability insurance with limits of \$1,000,000 per occurrence, \$2,000,000 aggregate other than products/completed operations; \$2,000,000 aggregate for products/completed. Commercial general liability coverage shall be written on an "occurrence" basis.
- (ii) Automobile liability insurance in an amount not less than \$1,000,000 combined single limit per accident for bodily injury and property damage from owned, non-owned, and hired automobiles.
- (iii) Workers' compensation insurance as required by the Laws and Regulations. In the event any employee(s), contractor(s), or subcontractor(s) engaged to perform any Work under the Agreement is not protected under the applicable workers' compensation laws, the Contractor shall provide adequate coverage for the protection of such employee(s), contractor(s), or subcontractor(s) not otherwise protected.
- (iv) In the event the Project concerns building construction or repair work, Contractor shall purchase and maintain "Builder's Risk" insurance. This insurance shall include the interests of the PWC, Contractor, and any Subcontractor(s) and shall be written on a one hundred percent (100%) completed value basis (full value as of the date that all construction is finished and includes the Contractor's Contract Price), and to remain in force until Completion of the Project.
- (v) Regardless of the nature of the work to be performed, coverage must also be provided for the theft or damage of building materials and supplies, which are not permanently attached or stored on Site for any period of time. This coverage shall be an "Installation Floater." If no building construction or repair is involved for the Project, the amount of the coverage shall equal the value of the materials stored on site.
- (b) Prior to initiating any Work on the Project, Contractor shall deliver certificates of insurance confirming each such coverage set forth above, and Contractor shall direct its insurers to provide annually to PWC certificates confirming each such coverage during the coverage period.
- (c) PWC shall be named as an additional insured in the comprehensive automobile and commercial liability insurance policies.
- (d) Contractor shall not reduce or allow the required insurance coverages to lapse without PWC's prior written approval. All policies for insurance must be endorsed to contain a provision giving PWC a thirty (30) calendar day prior written notice by certified mail of any cancellation of that policy or material reduction in coverage. Should a notice of cancellation be issued for non-payment of premiums or any part thereof, or should Contractor fail to provide and maintain certificates as set forth herein, PWC shall have the right, but shall not have the obligation, to pay such premium to the insurance company or to obtain such coverage and to deduct such payment from any sums that may be due or become due to Contractor, or to seek reimbursement for said payments from Contractor. Any such sums paid by PWC shall be due and payable immediately by Contractor upon notice from PWC.
- (e) The insurance coverage requirements shall not be construed as a limitation on

Contractor's responsibilities and liabilities pursuant to the terms and conditions of this Agreement. Contractor's obligation to maintain insurance for three (3) years after Completion of the Project shall survive the termination of this Agreement.

- (f) If Contractor fails to obtain and maintain any required insurance, PWC may exclude Contractor from the Site, impose an appropriate set-off against payment, and exercise PWC's termination rights pursuant to the Contract Documents.
- (g) PWC does not represent that insurance coverage and limits established in this Contract necessarily will be adequate to protect Contractor or Contractor's interests.

Article VII. Contractor's Responsibilities

Section 7.01 Supervision and Superintendence

- (a) Contractor shall supervise, inspect, and direct the Work competently and efficiently, devoting such attention and applying such skills and expertise as may be necessary to perform the Work in accordance with the Contract Documents. Contractor shall be solely responsible for the means, methods, techniques, sequences, and procedures of construction subject to the terms, provisions, and specifications set forth in the Contract Documents.
- (b) At all times during the progress of the Work, Contractor shall assign a competent superintendent, satisfactory to Project Engineer, to supervise the Work and to respond to Project Engineer concerning PWC's interests in the Work.
- (c) Contractor's superintendent shall have full authority to act on behalf of Contractor and all communications, instructions, directions, and notices given to the superintendent by the Project Engineer shall be binding to the Contractor.
- (d) Contractor's superintendent shall be responsible for coordination of the Work with other contractors or subcontractors. The superintendent shall not be replaced without written notice to PWC except under extraordinary circumstances.
- (e) Subcontractors
 - (i) Contractor shall submit the names and references all Subcontractors to the Project Engineer for approval before commencing any Work.
 - 1) In the event Contractor seeks to substitute any Subcontractor that was identified in Contractor's Bid, Contractor shall promptly provide PWC with: (1) the Subcontractor it seeks to substitute; (2) the identity of the Subcontractor to be substituted; and (3) the reason for the requested substitution.
 - 2) PWC will review the requested substitution within five (5) Business Days and provide written approval or denial of the substitution, with such approval not to be unreasonably withheld.
 - (ii) Contractor's superintendent shall be available to be present at the Site at any time that any Subcontractor(s) is performing any of the Work. Construction activity shall be

stopped if the Contractor's superintendent is not available to be at the Site.

Section 7.02 Labor; Working Hours

- (a) Contractor shall provide competent, suitably qualified personnel to survey and lay out the Work and perform construction as required by the Contract Documents. Contractor shall at all times maintain good discipline and order at the Site. Contractor shall remove from the Project any person who appears incompetent, disorderly, or otherwise unsatisfactory. Contractor shall also remove any person who appears in PWC's sole discretion to be incompetent, disorderly, or otherwise unsatisfactory
- (b) Except as otherwise required for the safety or protection of persons or the Work or property at the Site or adjacent thereto, and except as otherwise stated in the Contract Documents, all Work at the Site shall be performed on Business Days. Contractor will not perform Work on non-Business Days. Contractor may perform Work outside regular working hours or on Saturdays, Sundays, or legal holidays only with PWC's written consent, which will not be unreasonably withheld. In such circumstances, Contractor shall submit a written request to PWC at least two (2) Business Days prior to any Work that it requests to complete on a non-Business Day and PWC will, in its sole discretion, approve or deny such request. If such work outside of a Business Day is approved, PWC will set forth the specific parameters that Contractor must follow, including time of work, personnel, and any other issues.⁸

Section 7.03 Services, Materials, and Equipment

- (a) Unless otherwise specified in the Contract Documents, Contractor shall provide and assume full responsibility for all services, materials, equipment, labor, transportation, construction equipment and machinery, tools, appliances, fuel, power, light, heat, telephone, water, sanitary facilities, temporary facilities, and all other facilities and incidentals necessary for the performance, testing, start up, and Completion of the Project, whether or not such items are specifically called for in the Contract Documents.
- (b) All materials and equipment incorporated into the Work shall be of good quality and new, except as otherwise specified in the Contract Documents. All special warranties and guarantees required by the Specifications shall expressly run to the benefit of PWC. If required by PWC or its designee, Contractor shall furnish satisfactory evidence (including reports of required tests) as to the source, kind, and quality of materials and equipment.
- (c) All materials and equipment shall be stored, applied, installed, connected, erected, protected, used, cleaned, and conditioned in accordance with instructions of the applicable Supplier, except as otherwise may be specified in the Contract Documents.

Section 7.04 "Or Equals"

- (a) Whenever an item of material or equipment is specified or described in the Contract Documents by using the name of a proprietary item or the name of a particular Supplier, the specification or description of such an item is intended to establish the type, function, appearance, and quality required. Unless the specification or description contains or is followed by words reading that no like, equivalent, or "or equal" item is permitted, Contractor may request that Project Engineer authorize the use of other items of material or equipment under the circumstances described below.

General Conditions (Rev 7/2023)

- (i) If Project Engineer determines that an item of material or equipment proposed by Contractor is functionally equal to that named and sufficiently similar so that no change in related Work will be required, Project Engineer shall deem it an “or equal” item and confirm such in writing to Contractor. A proposed item of material or equipment will be considered functionally equal to an item so named if:
 - 1) in the exercise of reasonable judgment Project Engineer determines that:
 - a) it is at least equal in materials of construction, quality, durability, appearance, strength, and design characteristics;
 - b) it will reliably perform at least equally well the function and achieve the results imposed by the design concept of the completed Project as a functioning whole;
 - c) it has a proven record of performance and availability of responsive service; and
 - d) it is not objectionable to PWC.
 - 2) Contractor certifies that, if approved and incorporated into the Work:
 - a) there will be no increase in the Contract Price or Contract Times; and
 - b) it will conform substantially to the detailed requirements of the item specified in the Contract Documents.
- (b) Contractor shall provide all data in support of any proposed “or equal” item at Contractor’s expense.
- (c) Project Engineer will be allowed a reasonable time to evaluate each “or-equal” request. Project Engineer may require Contractor to furnish additional data about the proposed “or-equal” item. Project Engineer will be the sole judge of acceptability. Contractor shall not order, furnish, install, or utilize any “or-equal” it until Project Engineer has reviewed the request, determined that the proposed item is an “or-equal,” and provided written confirmation to Contractor.
- (d) Project Engineer’s denial of an “or-equal” request shall be final and binding and may not be reversed through an appeal under any provision of the Contract Documents.

Section 7.05 Concerning Subcontractors, Suppliers, and Others

- (a) Contractor may retain Subcontractors and Suppliers for the performance of parts of the Work. Such Subcontractors and Suppliers must be acceptable to PWC.
- (b) Contractor shall not subcontract more than forty-nine percent (49%) of the final Contract Price.
- (c) Contractor shall retain specific Subcontractors, Suppliers, or other individuals or entities for the performance of designated parts of the Work if required by the Contract Documents.
- (d) After the submittal of Contractor’s Bid or final negotiation of the terms of the Agreement, PWC may not require Contractor to retain any Subcontractor, Supplier, or other individual or entity to furnish or perform any of the Work.
- (e) Prior to entry into any binding subcontract or purchase order, Contractor shall submit to PWC the identity of the proposed Subcontractor or Supplier (unless PWC has already deemed such proposed Subcontractor or Supplier acceptable, during the bidding process

General Conditions (Rev 7/2023)

or otherwise). Such proposed Subcontractor or Supplier shall be deemed acceptable to PWC unless PWC raises a substantive, reasonable objection within five (5) Business Days.

- (f) No acceptance by PWC of any such Subcontractor, Supplier, or other individual or entity, whether initially or as a replacement, shall constitute a waiver of the right of PWC to the completion of the Work in accordance with the Contract Documents.
- (g) Contractor shall be fully responsible to PWC for all acts and omissions of the Subcontractors, Suppliers, and other individuals or entities performing or furnishing any of the Work just as Contractor is responsible for Contractor's own acts and omissions.
- (h) Contractor shall be solely responsible for scheduling and coordinating the Subcontractors, Suppliers, and all other individuals or entities performing or furnishing any of the Work.
- (i) Contractor shall restrict all Subcontractors, Suppliers, and such other individuals or entities performing or furnishing any of the Work from communicating with PWC, except through Contractor or in case of an emergency, or as otherwise expressly allowed herein.
- (j) All Work performed for Contractor by a Subcontractor or Supplier shall be pursuant to an appropriate contractual agreement that specifically binds the Subcontractor or Supplier to the applicable terms and conditions of the Contract Documents for the benefit of PWC.
- (k) PWC may furnish to any Subcontractor or Supplier, to the extent practicable, information about amounts paid to Contractor on account of Work performed for Contractor by the particular Subcontractor or Supplier.
- (l) Nothing in the Contract Documents:
 - (i) shall create for the benefit of any such Subcontractor, Supplier, or other individual or entity any contractual relationship between PWC or Design Engineer and any such Subcontractor, Supplier, or other individual or entity; nor
 - (ii) shall create any obligation on the part of PWC or Design Engineer to pay or to see to the payment of any money due any such Subcontractor, Supplier, or other individual or entity except as may otherwise be required by Laws and Regulations.

Section 7.06 Patent Fees and Royalties

- (a) Contractor shall pay all license fees and royalties and assume all costs incident to the use in the performance of the Work or the incorporation in the Work of any invention, design, process, product, or device that is the subject of patent rights or copyrights held by others. If a particular invention, design, process, product, or device is specified in the Contract Documents for use in the performance of the Work and if, to the actual knowledge of PWC, its use is subject to patent rights or copyrights calling for the payment of any license fee or royalty to others, the existence of such rights shall be disclosed by PWC in the Contract Documents.

Section 7.07 Permits

- (a) Unless otherwise specified in the Contract Documents, Contractor shall obtain and pay for all construction permits and licenses necessary to achieve Completion of the Project. Contractor shall timely seek assistance from PWC if necessary to obtain any permits or

General Conditions (Rev 7/2023)

licenses; provided that, the Contract Time shall not be extended if PWC determines, in its discretion, that Contractor delayed or otherwise did not act expeditiously in requesting such assistance. PWC shall assist Contractor, when necessary, in obtaining such permits and licenses. Contractor shall pay all governmental charges and inspection fees necessary for Completion of the Project that are applicable at the time of the submission of Contractor's Bid.

Section 7.08 Taxes

- (a) Contractor shall pay all sales, consumer, use, and other similar taxes required to be paid by Contractor in accordance with the applicable Laws and Regulations for the Project and which are applicable during the performance of the Work.

Section 7.09 Laws and Regulations

- (a) Contractor shall give all notices required by, and shall comply with, all Laws and Regulations applicable to the Project. Except as otherwise expressly required, PWC shall not be responsible for monitoring Contractor's compliance with any Laws or Regulations.
- (b) Contractor shall bear all resulting costs and losses for any of its actions or inactions that are contrary to Laws or Regulations.
- (c) PWC or Contractor may give notice to the other party of any changes after the submission of Contractor's Bid (or after the date when Contractor became bound under the Agreement) concerning any Laws or Regulations having an effect on the Contract Price or Contract Times, including but not limited to changes in Laws or Regulations having an effect on procuring permits and on sales, use, value-added, consumption, and other similar taxes. If PWC and Contractor are unable to agree on entitlement to or on the amount or extent, if any, of any adjustment in Contract Price or Contract Times resulting from such changes, then within 30 calendar days of such notice Contractor may submit a Change Proposal.

Section 7.10 Record Documents

- (a) Contractor shall maintain in good order one (1) printed record copy of all Drawings, Specifications, Addenda, Change Orders, Work Change Directives, Field Orders, written interpretations and clarifications, and approved Shop Drawings. These record documents, together with all approved Samples, will be available to Project Engineer for reference. Upon completion of the Work, Contractor shall deliver these record documents to PWC.

Section 7.11 Safety and Protection

- (a) Contractor shall be solely responsible for initiating, maintaining, and supervising all safety precautions and programs in connection with the Work. Such responsibility does not relieve Subcontractors of their responsibility for the safety of persons or property in the performance of their work, nor for compliance with applicable safety Laws and Regulations. Contractor shall take all necessary precautions for the safety of, and shall provide the necessary protection to prevent damage, injury, or loss to:
 - (i) all persons on the Site or who may be affected by the Work;
 - (ii) all the Work and materials and equipment to be incorporated therein, whether in storage on or off the Site; and

General Conditions (Rev 7/2023)

- (iii) other property at the Site or adjacent thereto, including trees, shrubs, lawns, walks, pavements, roadways, structures, other work in progress, utilities, and Underground Facilities not designated for removal, relocation, or replacement in the course of construction.
- (b) Contractor shall comply with all applicable Laws and Regulations relating to the safety of persons or property, or to the protection of persons or property from damage, injury, or loss, and shall erect and maintain all necessary safeguards for such safety and protection. Contractor shall notify PWC, the owners of adjacent property or Underground Facilities, and other contractors and owners performing work at or adjacent to the Site, when prosecution of the Work may affect them, and shall cooperate with them in the protection, removal, relocation, and replacement of their property or work in progress.
- (c) Contractor shall comply with the requirement of any of PWC's applicable health programs, which may be revised from time to time based on specific circumstances or applicable guidance from the Center for Disease Control or other applicable entity. Such health programs will be identified in the Special Conditions if applicable to the Project.
- (d) Contractor shall comply with the requirements of PWC's applicable safety programs. The Special Conditions identify any of PWC's safety programs that are applicable to the Project.
- (e) Contractor shall remedy, at its expense, all damage, injury, or loss to any property caused, directly or indirectly, in whole or in part, by Contractor, any Subcontractor, Supplier, or any other individual or entity directly or indirectly employed by any of them to perform any of the Work, or anyone for whose acts any of them may be liable.
- (f) Contractor's duties and responsibilities for safety and protection shall continue until such time as Completion of the Project is achieved.
- (g) Contractor's duties and responsibilities for safety and protection shall resume whenever Contractor or any Subcontractor or Supplier returns to the Site to fulfill warranty or correction obligations, or to conduct other tasks arising from the Contract Documents.
- (h) Contractor shall designate in writing to PWC a qualified and experienced safety representative at the Site whose duties and responsibilities shall be the prevention of accidents and the maintaining and supervising of safety precautions and programs.

Section 7.12 Emergencies

- (a) In emergencies affecting the safety or protection of persons or the Work or property at the Site or adjacent thereto, Contractor is obligated to, and shall, act to prevent threatened damage, injury, or loss. Contractor shall give PWC prompt written notice if Contractor believes that any significant changes in the Work or variations from the Contract Documents have been caused or are required as a result of any emergency. If PWC determines that a change in the Contract Documents is required because of the action taken by Contractor in response to such an emergency, a Work Change Directive or Change Order will be issued.

Section 7.13 Shop Drawings, Samples, and Other Submittals

- (a) Contractor shall timely submit Shop Drawings and Samples required by the Contract

General Conditions (Rev 7/2023)

Documents to Project Engineer for review and approval in accordance with applicable specifications.

- (b) Before submitting a Shop Drawing or Sample, Contractor shall have
 - (i) reviewed the Shop Drawing or Sample with other Shop Drawings and Samples and with the requirements of the Work and the Contract Documents;
 - (ii) verified all measurements, quantities, dimensions, performance and design criteria, installation requirements, materials, catalog numbers, and similar information;
 - (iii) verified the suitability of all materials and equipment offered with respect to the indicated application, fabrication, shipping, handling, storage, assembly, and installation pertaining to the performance of the Work; and
 - (iv) verified all information relative to Contractor's responsibilities for means, methods, techniques, sequences, and procedures of construction, and safety precautions and programs incident thereto.
- (c) With each submittal, Contractor shall give Project Engineer specific written notice of any variations that the Shop Drawing or Sample may have from the requirements of the Contract Documents. This notice shall be a written communication separate from the Shop Drawings or Sample submittal; and, in addition, in the case of Shop Drawings by a specific notation made on each Shop Drawing submitted to PWC for review and approval of each such variation.
- (d) Where a Shop Drawing or Sample is required by the Contract Documents, any related Work performed prior to Project Engineer's review and approval of the pertinent submittal will be at the sole expense and responsibility of Contractor.
- (e) Project Engineer will provide timely review of any required Shop Drawings and Samples. Such review, and subsequent determination of approval, will be only to determine if the items covered by the submittals will, after installation or incorporation in the Work, conform to the information given in the Contract Documents and be compatible with the design concept of the completed Project as a functioning whole as indicated by the Contract Documents.
- (f) Project Engineer's review and approval will not extend to means, methods, techniques, sequences, or procedures of construction or to safety precautions or programs incident thereto.
- (g) Project Engineer's review and approval of a Shop Drawing or Sample, or of a variation from the requirements of the Contract Documents, shall not change the Contract Times or Contract Price, unless such changes are included in a Change Order.
- (h) Project Engineer's receipt, review, acceptance or approval of a Shop Drawing, Sample, or other submittal shall not result in such item becoming a Contract Document.
- (i) Contractor shall perform the Work in compliance with the requirements and commitments set forth in approved Shop Drawings and Samples.
- (j) Resubmittal Procedures:
 - (i) Contractor shall make corrections required by Project Engineer and shall return the

General Conditions (Rev 7/2023)

required number of corrected copies of Shop Drawings and submit new Samples as required for review and approval. Contractor shall direct specific attention in writing to revisions other than the corrections called for by PWC or Project Engineer on previous submittals.

- (ii) Contractor shall furnish required submittals with sufficient information and accuracy to obtain required approval of an item with no more than three (3) submittals. If PWC has engaged a Design Engineer for the Project, Design Engineer will record Design Engineer's time for reviewing a fourth or subsequent submittal of a Shop Drawings, sample, or other item requiring approval, and Contractor shall be responsible for Design Engineer's charges to PWC for such time. PWC may impose a set-off against payments due to Contractor to secure reimbursement for such charges.
- (iii) If Contractor requests a change of a previously approved submittal item, Contractor shall be responsible for Design Engineer's charges to PWC for its review time, and PWC may impose a set-off against payments due to Contractor to secure reimbursement for such charges, unless the need for such change is beyond the control of Contractor.

Section 7.14 Contractor's General Warranty and Guarantee

- (a) In order to induce PWC to enter into an Agreement with Contractor for the Project, Contractor warrants and guarantees to PWC that:
 - (i) Contractor is duly licensed in the State of North Carolina to complete all Work necessary for the Project, is duly organized, validly existing and in good standing and has all requisite powers, rights, and authority to execute, enter into, and perform the Agreement in accordance with the terms and conditions of the Agreement, and the Agreement constitutes a legal, valid, and binding obligation of Contractor enforceable against it in accordance with its terms.
 - (ii) Contractor has read the Contract Documents, and acknowledges and understands all data, materials, specifications, and requirements identified in the Contract Documents.
 - (iii) Contractor has visited the site for the Project, conducted a thorough, visual examination of the site and adjacent areas, and become familiar with and is satisfied as to the general, local, and site conditions that may affect cost, progress, and performance in completing the Project.
 - (iv) Contractor is familiar with and is satisfied as to all laws and regulations that may affect cost, progress, and performance to complete the Project.
 - (v) Contractor has carefully studied all: (1) reports of explorations and tests of subsurface conditions at or adjacent to the site and all drawings of physical conditions relating to existing surface or subsurface structures at the site that have been identified in the Detail Specifications and any accompanying reports and drawings, and (2) reports and drawings relating to any Hazardous Environmental Condition at or adjacent to the site that have been identified in the Contract Documents and any accompanying reports and drawings.
 - (vi) Contractor has considered the information known to Contractor itself; information commonly known to contractors doing business in the locality of the Site; information and observations obtained from visits to the Site; the Contract Documents; and the Site-related reports and drawings identified in the Contract Documents, if any, with respect to the effect of such information, observations, and documents on (1) the cost, progress, and performance of the Work; (2) the means, methods, techniques, sequences, and procedures of construction to be employed by Contractor; and (3) Contractor's safety precautions and programs.

General Conditions (Rev 7/2023)

- (vii) Based on the information and observations referred to in subsection “(v)” of this Section, Contractor agrees that no further examinations, investigations, explorations, tests, studies, or data are necessary for the performance of the Work at the Contract Price and in accordance with the other terms and conditions of the Contract Documents.
 - (viii) Contractor is aware of the general nature of work to be performed by PWC and others at the Site that relates to the Work as indicated in the Contract Documents.
 - (ix) Contractor has given PWC written notice of all conflicts, errors, ambiguities, or discrepancies that Contractor has discovered in the Contract Documents, and the written resolution thereof by PWC is acceptable to Contractor.
 - (x) The Contract Documents are generally sufficient to indicate and convey understanding of all terms and conditions for performance and furnishing of the Work.
 - (xi) Contractor’s entry into this Agreement constitutes an incontrovertible representation by Contractor that, without exception, all prices in the Agreement are premised upon performing and furnishing the Work required by the Contract Documents.
 - (xii) Contractor has no business or personal relationship with any PWC Commissioner, officer, director, manager, or supervisor and Contractor covenants to disclose immediately to PWC any such relationship that develops during the performance of Work on the Project.
- (b) Contractor’s obligation to perform and complete the Work in accordance with the Contract Documents shall be absolute. None of the following will constitute an acceptance of Work that is not in accordance with the Contract Documents or a release of Contractor’s obligation to perform the Work in accordance with the Contract Documents:
- (i) observations by Project Engineer;
 - (ii) recommendation by Project Engineer or payment by PWC of any progress or final payment;
 - (iii) the issuance of a certificate of Substantial Completion by Project Engineer or any payment related thereto by PWC;
 - (iv) use or occupancy of the Work or any part thereof by PWC;
 - (v) any review and approval of a Shop Drawing or Sample submittal;
 - (vi) the issuance of a notice of acceptability by Project Engineer;
 - (vii) any inspection, test, or approval by others; or
 - (viii) any correction of defective Work by PWC.
- (c) If the Contract Documents requires the Contractor to accept the assignment of a contract entered into by PWC, then the specific warranties, guarantees, and correction obligations contained in the assigned contract shall govern with respect to Contractor’s performance obligations to PWC for the Work described in the assigned contract.

Section 7.15 Indemnification

- (a) Contractor shall indemnify, defend, and hold harmless PWC and its Commissioners, officers, employees, agents, and representatives and the City and its elected officials, managers, employees, agents, and representatives and Designer (collectively “Indemnitees”) from and against all claims, actions, liabilities, damages, losses, costs, and expenses (including, without limitation, injury to or death of any persons and damage to property, economic and consequential damages and attorneys’ fees) asserted by one or more third parties against one or more of the Indemnitees if the Fault of one or more Responsible Persons is a proximate cause of the loss, damage, or expense indemnified.
- (b) Contractor’s obligation to indemnify, defend, and hold harmless the Indemnitees shall survive the termination of the Agreement.

- (c) In any and all claims against the Indemnitees of Contractor, any Subcontractor, any Supplier, or any individual or entity directly or indirectly employed by any of them to perform any of the Work, or anyone for whose acts any of them may be liable, Contractor's indemnification obligation shall not be limited in any way by any limitation on the amount or type of damages, compensation, or benefits payable by or for Contractor or any such Subcontractor, Supplier, or other individual or entity under workers' compensation acts, disability benefit acts, or other employee benefit acts.

Section 7.16 Claims Procedure

- (a) PWC shall notify the Contractor of all potential claims related to the Work within seven (7) calendar days of receiving notification or having knowledge of such potential claim. Should the Contractor receive a potential claim related to the Work, the Contractor shall notify PWC within seven (7) calendar days of receiving notification. The Contractor shall provide the claimant and PWC with a written response acknowledging receipt of the claim within seven (7) calendar days.
- (b) If the Contractor meets with the Claimant about the claim, a representative designated by PWC shall be present at all times. PWC shall maintain a record of any claim received, and the steps taken to resolve. PWC shall also concurrently investigate each case. The Contractor agrees to furnish PWC any information regarding the claim, the actions which led to the claim and/or the investigation of the claim. Contractor shall provide their proposed response to PWC within thirty (30) calendar days of receiving the claim. Upon receipt of the response PWC and the Contractor will discuss and reach a mutual agreement of the response necessary to send to the Claimant within fifteen (15) calendar days. Once the agreement is made the Contractor shall make a formal written resolution to the claimant.
- (c) Failure to act in good faith or respond to a claim in the timelines established by the Contract Documents will constitute a lack of response by the Contractor, therefore validating the claim. PWC will deduct the total amount of the claim from the monthly pay application. Failure to comply with the above requirements for resolving claims may, at the sole discretion of PWC, result in breach of contract.
- (d) The Contractor is aware of these claims procedures and understands that it is the PWC's practice to pursue reimbursement/subrogation for any and all claims related expenses, which are incurred as a result of the Contractor's performance under this Contract Documents and allowed within the applicable statute of limitations.

Section 7.17 Delegation of Professional Design Services

- (a) Contractor will not be required to provide professional design services unless such services are specifically required by the Contract Documents for a portion of the Work or unless such services are required to carry out Contractor's responsibilities for construction means, methods, techniques, sequences and procedures. Contractor shall not be required to provide professional services in violation of applicable Laws and Regulations.
- (b) If professional design services or certifications by a design professional related to systems, materials, or equipment are specifically required of Contractor by the Contract Documents, PWC will specify all performance and design criteria that such services must satisfy.

General Conditions (Rev 7/2023)

Contractor shall cause such services or certifications to be provided by a properly licensed professional, whose signature and seal shall appear on all drawings, calculations, specifications, certifications, and other submittals prepared by such professional. Shop Drawings and other submittals related to the Work designed or certified by such professional, if prepared by others, shall bear such professional's written approval when submitted to PWC.

- (c) PWC shall be entitled to rely upon the adequacy, accuracy, and completeness of the services, certifications, or approvals performed by such design professionals, provided PWC has specified to Contractor all performance and design criteria that such services must satisfy.
- (d) Pursuant to this Section, PWC's, or its designee's, review and approval of design calculations and design drawings will be only for the limited purpose of checking for conformance with performance and design criteria given and the design concept expressed in the Contract Documents. PWC specifically retains final approval of such submittals.
- (e) Contractor shall not be responsible for the adequacy of the performance or design criteria specified by PWC.

Article VIII. PWC's Responsibilities

- (a) In awarding the bid to Contractor and executing the applicable Agreement, PWC acknowledges the following responsibilities:
 - (i) Except as otherwise provided in these General Conditions, PWC shall issue all communications directly to Contractor or its designee.
 - (ii) PWC may at its discretion replace Design Engineer and Project Engineer. The replacement Design Engineer or Project Engineer's status under the Contract Documents shall be that of the former Design Engineer or Project Engineer.
 - (iii) PWC shall promptly furnish the data required of PWC under the Contract Documents.
 - (iv) PWC shall make payments to Contractor when they are due as provided in the Contract Documents.
 - (v) PWC shall not supervise, direct, or have control or authority over, nor be responsible for, Contractor's means, methods, techniques, sequences, or procedures of construction, or the safety precautions and programs incident thereto, or for any failure of Contractor to comply with Laws and Regulations applicable to the performance of the Work. PWC will not be responsible for Contractor's failure to perform the Work in accordance with the Contract Documents.
 - (vi) Upon request of Contractor, PWC shall furnish to Contractor reasonable evidence that financial arrangements have been made to satisfy PWC's obligations under the Contract Documents (including obligations under proposed changes in the Work).
 - (vii) While at the Site, PWC's employees and representatives shall comply with the specific applicable requirements of Contractor's safety programs of which PWC has been informed.
 - (viii) PWC shall furnish copies of any applicable PWC safety program(s) to Contractor, which Contractor shall review and implement.

Article IX. Amending the Contract Documents; Changes in the Work

Section 9.01 Amending and Supplementing Contract Documents

- (a) The Contract Documents may be amended or supplemented by a Change Order, a Work Change Directive, or a Field Order.
 - (i) Change Orders: If an amendment or supplement to the Contract Documents includes a change in the Contract Price or the Contract Times, such amendment or supplement must be set forth in a Change Order. A Change Order also may be used to establish amendments and supplements of the Contract Documents that do not affect the Contract Price or Contract Times.
 - (ii) Work Change Directives: A Work Change Directive will not change the Contract Price or the Contract Times, but is evidence that the parties expect that the modification ordered or documented by a Work Change Directive will be incorporated in a subsequently issued Change Order, following negotiations by the parties as to the Work Change Directive's effect, if any, on the Contract Price and Contract Times; or, if negotiations are unsuccessful, by a determination under the terms of the Contract Documents governing adjustments, expressly including Paragraph 9.04 regarding change of Contract Price. Contractor must submit any Change Proposal seeking an adjustment of the Contract Price or the Contract Times, or both, no later than 30 days after the completion of the Work set out in the Work Change Directive. PWC must submit any dispute or request seeking an adjustment of the Contract Price or the Contract Times, or both, no later than 60 days after issuance of the Work Change Directive.
 - (iii) Field Orders: Project Engineer may authorize minor changes in the Work if the changes do not involve an adjustment in the Contract Price or the Contract Times and are compatible with the design concept of the completed Project as a functioning whole as indicated by the Contract Documents. Such changes will be accomplished by a Field Order and will be binding on PWC and on Contractor, which shall perform promptly the Work involved. If Contractor believes that a Field Order justifies an adjustment in the Contract Price or Contract Times, or both, then before proceeding with the Work at issue, Contractor shall submit a Change Proposal as provided herein.

Section 9.02 PWC-Authorized Changes in the Work

- (a) Without invalidating the Agreement and without notice to any surety, PWC may, at any time or from time to time, order additions, deletions, or revisions in the Work. Such changes shall be supported by Design Engineer's recommendation when applicable and to the extent the change involves the design (as set forth in the Drawings, Specifications, or otherwise), or other engineering or technical matters. Such changes may be accomplished by a Change Order or by a Work Change Directive. Upon receipt of any such document, Contractor shall promptly proceed with the Work as revised. Nothing in this paragraph shall obligate Contractor to undertake work that Contractor reasonably concludes cannot be performed in a manner consistent with Contractor's safety obligations under the Contract Documents or Laws and Regulations.

Section 9.03 Unauthorized Changes in the Work

- (a) Contractor shall not be entitled to an increase in the Contract Price or an extension of the Contract Times with respect to any work performed that is not required by the Contract Documents, as amended, modified, or supplemented.

Section 9.04 Change of Contract Price

- (a) The Contract Price may only be changed by a Change Order. Any Change Proposal for an adjustment in the Contract Price shall comply with the provisions of these General Conditions.
- (b) An adjustment in the Contract Price will be determined as follows:
 - (i) where the Work involved is covered by unit prices contained in the Contract Documents, then by application of such unit prices to the quantities of the items involved; or
 - (ii) where the Work involved is not covered by unit prices contained in the Contract Documents, then by a mutually agreed lump sum (which may include an allowance for overhead and profit as agreed to in writing by the Parties); or
 - (iii) where the Work involved is not covered by unit prices contained in the Contract Documents and the Parties do not reach mutual agreement to a lump sum, then on the basis of the Cost of the Work plus a reasonable Contractor's fee for overhead and profit.
- (c) Contractor's Fee: When applicable, the Contractor's fee for overhead and profit shall be determined as follows:
 - (i) a mutually acceptable fixed fee; or
 - (ii) if a fixed fee is not agreed upon, then a fee based on the following percentages of the various portions of the Cost of the Work:
 - 1) for unit prices, the Contractor's fee shall be fifteen percent (15%);
 - 2) for all other costs incurred, the Contractor's fee shall be five percent (5%);
 - 3) the amount of credit to be allowed by Contractor to PWC for any change that results in a net decrease in the Contract Price will be the amount of the actual net decrease in cost plus a deduction in Contractor's fee by an amount equal to five percent of such net decrease; and
 - 4) when both additions and credits are involved in any one change, the adjustment in Contractor's fee shall be computed on the basis of the net change.

Section 9.05 Change of Contract Times

- (a) The Contract Times may only be changed by a Change Order. Any Change Proposal for an adjustment in the Contract Times shall comply with the provisions of Paragraph 9.06.
- (b) An adjustment of the Contract Times shall be subject to the limitations set forth in these Contract Document as it concerns delays in Contractor's progress.

Section 9.06 Change Proposals

- (a) Contractor shall submit a Change Proposal to PWC to request an adjustment in the Contract Times and/or Contract Price. The Change Proposal shall specify any proposed change in Contract Times or Contract Price, or both, or other proposed relief, and explain the reason for the proposed change, with citations to any governing or applicable provisions of the Contract Documents.
- (i) Procedures: Contractor shall submit each Change Proposal to PWC promptly (but in no event later than 30 days) after the start of the event giving rise thereto, or after such initial decision. The Contractor shall submit supporting data, including the proposed change in

General Conditions (Rev 7/2023)

Contract Price or Contract Time (if any), to PWC within 15 calendar days after the submittal of the Change Proposal. The supporting data shall be accompanied by a written statement that the supporting data are accurate and complete, and that any requested time or price adjustment is the entire adjustment to which Contractor believes it is entitled as a result of said event.

- (ii) PWC Action: PWC will review each Change Proposal and, within 30 calendar days after receipt of the Contractor's supporting data, either deny the Change Proposal in whole, approve it in whole, or deny it in part and approve it in part. Such actions shall be in writing to Contractor. If PWC does not take action on the Change Proposal within 30 calendar days, then the Change Proposal is deemed denied, thereby commencing the time for appeal under these General Conditions.
- (iii) Binding Decision: PWC's decision will be final and binding unless Contractor appeals the decision.

Section 9.07 Execution of Change Orders

- (a) PWC and Contractor shall execute appropriate Change Orders covering:
 - (i) changes in the Contract Price or Contract Times that are agreed to by the parties, including any undisputed sum or amount of time for Work performed in accordance with a Work Change Directive;
 - (ii) changes in Contract Price resulting from a PWC set-off, unless Contractor has duly contested such set-off;
 - (iii) changes in the Work which are: (a) ordered by PWC, (b) required because of PWC's acceptance of defective Work or PWC's correction of defective Work, or (c) agreed to by the parties, subject to the need for Design Engineer's recommendation if the change in the Work involves the design (as set forth in the Contract Documents), or other engineering or technical matters; and
 - (iv) changes in the Contract Price or Contract Times, or other changes, which embody the substance of any final and binding results.
- (b) If PWC or Contractor refuses to execute a Change Order that is required to be executed under the terms of this Section, it shall be deemed to be of full force and effect as if fully executed.

Section 9.08 Notification to Surety

- (a) If the provisions of any bond require notice to be given to a surety of any change affecting the general scope of the Work or the provisions of the Contract Documents (including, but not limited to, Contract Price or Contract Times), the giving of any such notice will be Contractor's responsibility. The amount of each applicable bond will be adjusted to reflect the effect of any such change.

Article X. Tests, Inspections, and Approvals; Correction, Removal, or Acceptance of Defective Work

Section 10.01 Access to Work

- (a) PWC, Design Engineer, their consultants and other representatives and personnel of PWC, independent testing laboratories, and authorities having jurisdiction will have access to the Site and the Work at reasonable times for their observation, inspection, and testing.

General Conditions (Rev 7/2023)

Contractor shall provide them proper and safe conditions for such access and advise them of Contractor's safety procedures and programs so that they may comply therewith as applicable.

Section 10.02 Tests, Inspections, and Approvals

- (a) Contractor shall give Project Engineer timely notice of readiness of the Work (or specific parts thereof) for all required inspections and tests and shall cooperate with inspection and testing personnel to facilitate required inspections and tests.
- (b) PWC shall retain and pay for the initial services of an independent inspector, testing laboratory, or other qualified individual or entity to perform all inspections and tests expressly required by the Contract Documents to be furnished and paid for by PWC, except those costs incurred in connection with tests or inspections of covered Work shall be governed by the provisions of Paragraph 10.05.
- (c) If Laws or Regulations of any public body having jurisdiction require any Work (or part thereof) specifically to be inspected, tested, or approved by an employee or other representative of such public body, Contractor shall assume full responsibility for arranging and obtaining such inspections, tests, or approvals, pay all costs in connection therewith, and furnish the required certificates of inspection or approval to PWC.
- (d) Contractor shall be responsible for arranging, obtaining, and paying for all inspections and tests required:
 - (i) by the Contract Documents, unless the Contract Documents expressly allocate responsibility for a specific inspection or test to PWC;
 - (ii) to attain PWC's and Design Engineer's acceptance of materials or equipment to be incorporated in the Work;
 - (iii) by manufacturers of equipment furnished under the Contract Documents;
 - (iv) for testing, adjusting, and balancing of mechanical, electrical, and other equipment to be incorporated into the Work; and
 - (v) for acceptance of materials, mix designs, or equipment submitted for approval prior to Contractor's purchase thereof for incorporation in the Work.

Such inspections and tests shall be performed by independent inspectors, testing laboratories, or other qualified individuals or entities acceptable to PWC, as confirmed in writing by Project Engineer to Contractor.

- (e) If the Contract Documents require the Work (or part thereof) to be approved by PWC or its designee, then Contractor shall assume full responsibility for arranging and obtaining such approvals.
- (f) If any Work (or the work of others) that is to be inspected, tested, or approved is covered by Contractor without written concurrence of Project Engineer, Contractor shall, if requested by Project Engineer, uncover such Work for observation. Such uncovering shall be at Contractor's expense unless Contractor had given PWC timely notice of Contractor's intention to cover the same and PWC had not acted with reasonable promptness in response to such notice.

Section 10.03 Defective Work

General Conditions (Rev 7/2023)

- (a) It is Contractor's obligation to assure that the Work is not defective.
- (b) PWC or its designee has the authority to determine whether Work is defective, and to reject defective Work.
- (c) Prompt notice of all defective Work of which PWC has actual knowledge will be given to Contractor.
- (d) Promptly after receipt of written notice of defective Work, Contractor shall correct all such defective Work, whether or not fabricated, installed, or completed, or, if PWC has rejected the defective Work, remove it from the Project and replace it with Work that is not defective.
- (e) When correcting defective Work, Contractor shall take no action that would void or otherwise impair PWC's special warranty and guarantee, if any, on said Work.
- (f) In addition to its correction, removal, and replacement obligations with respect to defective Work, Contractor shall pay all claims, costs, losses, and damages arising out of or relating to defective Work, including but not limited to the cost of the inspection, testing, correction, removal, replacement, or reconstruction of such defective Work, fines levied against PWC by governmental authorities because the Work is defective, and the costs of repair or replacement of work of others resulting from defective Work. Prior to final payment, if PWC and Contractor are unable to agree as to the measure of such claims, costs, losses, and damages resulting from defective Work, then PWC may impose a reasonable set-off against payments due.

Section 10.04 Acceptance of Defective Work

- (a) If, instead of requiring correction or removal and replacement of defective Work, PWC prefers to accept it, PWC may do so (subject, if such acceptance occurs prior to final payment, to Design Engineer's confirmation that such acceptance is in general accord with the design intent and applicable engineering principles and will not endanger public safety).
- (b) Contractor shall pay all claims, costs, losses, and damages attributable to PWC's evaluation of and determination to accept such defective Work (such costs to be approved by PWC as to reasonableness), and for the diminished value of the Work to the extent not otherwise paid by Contractor. If any such acceptance occurs prior to final payment, the necessary revisions in the Contract Documents with respect to the Work shall be incorporated in a Change Order.
- (c) If the parties are unable to agree as to the decrease in the Contract Price, reflecting the diminished value of Work so accepted, then PWC may impose a reasonable set-off against payments due. If the acceptance of defective Work occurs after final payment, Contractor shall pay an appropriate amount to PWC.

Section 10.05 Uncovering Work

- (a) PWC has discretion to require, at its initial cost, additional inspection or testing of the Work, whether or not the Work is fabricated, installed, or completed.
- (b) If any Work is covered contrary to the written request of PWC, then Contractor shall, if requested by PWC or its designee, uncover such Work for observation, and then replace

the covering, all at Contractor's expense.

- (c) If PWC considers it necessary or advisable that covered Work be observed by PWC or inspected or tested by others, then Contractor, at PWC's request, shall uncover, expose, or otherwise make available for observation, inspection, or testing as PWC may require, that portion of the Work in question, and provide all necessary labor, material, and equipment.
 - (i) If it is found that the uncovered Work is defective, Contractor shall be responsible for all claims, costs, losses, and damages arising out of or relating to such uncovering, exposure, observation, inspection, and testing, and of satisfactory replacement or reconstruction (including but not limited to all costs of repair or replacement of work of others); and pending Contractor's full discharge of this responsibility PWC shall be entitled to impose a reasonable set-off against payments due.
 - (ii) If the uncovered Work is not found to be defective, Contractor shall be allowed an increase in the Contract Price or an extension of the Contract Times, or both, directly attributable to such uncovering, exposure, observation, inspection, testing, replacement, and reconstruction. If the parties are unable to agree as to the amount or extent thereof, then Contractor may submit a Change Proposal within 30 calendar days of the determination that the Work is not defective.

Section 10.06 PWC May Stop the Work

- (a) If the Work is defective, or Contractor fails to supply sufficiently skilled workers or suitable materials or equipment, or fails to perform the Work in such a way that the completed Work will conform to the Contract Documents, then PWC may order Contractor to stop the Work, or any portion thereof, until the cause for such order has been eliminated; however, this right of PWC to stop the Work shall not give rise to any duty on the part of PWC to exercise this right for the benefit of Contractor, any Subcontractor, any Supplier, any other individual or entity, or any surety for, or employee or agent of any of them.

Section 10.07 PWC May Correct Defective Work

- (a) If Contractor fails within the time specified by PWC in a written notice from PWC to correct defective Work, or to remove and replace rejected Work as required by PWC, or if Contractor fails to perform the Work in accordance with the Contract Documents, or if Contractor fails to comply with any other provision of the Contract Documents, then PWC may, after seven (7) calendar days written notice to Contractor, correct or remedy any such deficiency.
- (b) In exercising the rights and remedies under this Section, PWC shall proceed expeditiously. In connection with such corrective or remedial action, PWC may exclude Contractor from all or part of the Site, take possession of all or part of the Work and suspend Contractor's services related thereto, and incorporate in the Work all materials and equipment stored at the Site or for which PWC has paid Contractor but which are stored elsewhere. Contractor shall allow PWC and its officers, employees, representatives, agents and other contractors, and Design Engineer and its employees and agents access to the Site to enable PWC to exercise the rights and remedies under this Section.
- (c) All claims, costs, losses, and damages incurred or sustained by PWC in exercising the rights and remedies under this Section will be charged against Contractor as set-offs against payments due. Such claims, costs, losses and damages will include but not be limited to all costs of repair, or replacement of work of others destroyed or damaged by

correction, removal, or replacement of Contractor's defective Work.

- (d) Contractor shall not be allowed an extension of the Contract Times because of any delay in the performance of the Work attributable to the exercise by PWC of PWC's rights and remedies under this Section.

Article XI. Claims

Section 11.01 Claims Process

- (a) The following disputes between PWC and Contractor shall be submitted to the Claims process set forth in this Article:
 - (i) Appeals by PWC or Contractor of Design Engineer's decisions regarding Change Proposals;
 - (ii) PWC or Contractor's demands for adjustments in the Contract Price or Contract Times, or other relief under the Contract Documents; and
 - (iii) Disputes that Design Engineer has been unable to address because they do not involve the design (as set forth in the Contract Documents), the acceptability of the Work, or other engineering or technical matters.

Section 11.02 Submittal of Claim

- (a) The party submitting a claim shall deliver it directly to the other party to the Agreement promptly (but in no event later than 30 calendar days) after the start of the event giving rise thereto; in the case of appeals regarding Change Proposals within 30 calendar days of the decision under appeal. The responsibility to substantiate a claim shall rest with the party making the claim. In the case of a claim by Contractor seeking an increase in the Contract Times or Contract Price, or both, Contractor shall certify that the claim is made in good faith, that the supporting data are accurate and complete, and that to the best of Contractor's knowledge and belief the amount of time or money requested accurately reflects the full amount to which Contractor is entitled.

Section 11.03 Review and Resolution

- (a) The party receiving a Claim shall review it thoroughly, giving full consideration to its merits. The two parties shall seek to resolve the Claim through the exchange of information and direct negotiations. The parties may extend the time for resolving the Claim by mutual agreement. All actions taken on a Claim shall be stated in writing and submitted to the other party.

Section 11.04 Dispute Resolution

- (a) In the event of any dispute, controversy, or claim of any kind or nature arising under or in connection with this Agreement (a "Dispute") and involving any two or more of the following parties, PWC, Design Engineer, Contractor or any subcontractor of Contractor, the party initiating the Dispute shall serve written notice of a Dispute on the party(ies) to the dispute, and those parties shall endeavor to settle the dispute first through direct, informal discussions between the parties' selected representatives. Any such representative(s) shall have binding authority to settle the Dispute. In the event the parties do not settle the Dispute within ten (10) calendar days from the date of written notice of the Dispute, any

party to the Dispute may, by written notice to the other party(ies), engage a mediator certified under the laws of the State of North Carolina to mediate the Dispute within thirty (30) calendar days of such notice. The parties to the Dispute shall attend mediation in good faith. In the event mediation is unsuccessful, any party to the dispute may initiate arbitration proceedings. Any controversy or claim arising out of or relating to the Contract Documents, or the breach thereof, shall be settled by binding arbitration administered by the American Arbitration Association under its Construction Industry Arbitration Rules, and judgment on the award rendered by the arbitrator(s) may be entered in any court having jurisdiction thereof. All of the foregoing dispute resolution procedures shall be held in Cumberland County, North Carolina. The costs of the mediator and arbitrator in a dispute resolution process shall be divided equally among the parties to the process; provided, however, PWC shall bear at least one-third of the cost if PWC is a party to the dispute resolution and the remainder of the cost shall be divided equally among the other parties participating in the dispute resolution. PWC shall, in its contractual arrangements with Design Engineer, and Contractor shall, in its contracts with Subcontractors and they in their contracts with lower-tier subcontractors authorize and direct such parties to participate in the dispute resolution procedures set forth in this Section. Unless otherwise directed in writing by PWC, Contractor shall continue the Project and maintain compliance with the scheduling deadlines set forth in the Contract Documents during any dispute resolution proceedings. If Contractor continues to perform, PWC shall make payments due for the continued performance in accordance with this Agreement. The provisions of this Section shall not extend any applicable statutes of limitation or repose.

Article XII. Payments to Contractor; Set-Offs; Completion; Correction Period

Section 12.01 Progress Payments

- (a) The Schedule of Values will serve as the basis for progress payments and will be incorporated into a form of Application for Payment acceptable to the Project Engineer. Progress payments on account of Unit Price Work will be based on the number of units completed during the pay period. Progress payments for cost-based Work will be based on the Cost of the Work completed by the Contractor during the pay period.
- (b) Applications for Payments:
 - (i) Contractor shall submit to Project Engineer for review an Application for Payment filled out and signed by Contractor covering the Work completed as of the date of the Application and accompanied by such supporting documentation as is required by the Contract Documents. If payment is requested on the basis of materials and equipment not incorporated in the Work but delivered and suitably stored at the Site or another location agreed to in writing, the Application for Payment shall also be accompanied by a bill of sale, invoice, or other documentation warranting that PWC has received the materials and equipment free and clear, and evidence that the materials and equipment are covered by appropriate property insurance, a warehouse bond, or other arrangements to protect PWC's interest.
 - (ii) Beginning with the second Application for Payment, each Application shall include an affidavit of Contractor stating that all previous progress payments received on account of the Work have been applied on account to discharge Contractor's legitimate obligations associated with prior Applications for Payment.
 - (iii) The amount of retainage for progress payments will be as stipulated in the Contract

Documents.

(c) Review of Applications:

- (i) Project Engineer will, within ten (10) Business Days after receipt of each Application for Payment, including each resubmittal, either indicate in writing a recommendation of payment and present the Application to PWC, or return the Application to Contractor indicating in writing Project Engineer's reason(s) for refusing to recommend payment. In the latter case, the Contractor may make the necessary corrections and resubmit the Application.
- (ii) Project Engineer's recommendation of any payment requested in an Application for Payment will constitute a representation by Project Engineer to PWC, based on Project Engineer's observations of the executed Work, and on Project Engineer's review of the Application for Payment and the accompanying data and schedules, that to the best of Project Engineer's knowledge, information, and belief:
 - 1) the Work has progressed to the point indicated;
 - 2) the quality of the Work is generally in accordance with the Contract Documents (subject to an evaluation of the Work as a functioning whole prior to or upon Substantial Completion, the results of any subsequent tests called for in the Contract Documents, a final determination of quantities and classifications for Unit Price Work, and any other qualifications stated in the recommendation); and
 - 3) the conditions precedent to Contractor's being entitled to such payment appear to have been fulfilled in so far as it is Project Engineer's responsibility to observe the Work.
- (iii) By recommending any such payment Project Engineer will not thereby be deemed to have represented that:
 - 1) inspections made to check the quality or the quantity of the Work as it has been performed have been exhaustive, extended to every aspect of the Work in progress, or involved detailed inspections of the Work beyond the responsibilities specifically assigned to Project Engineer in the Contract Documents; or
 - 2) there may not be other matters or issues between the parties that might entitle Contractor to be paid additionally by PWC or entitle PWC to withhold payment to Contractor.
- (iv) Neither Project Engineer's review of Contractor's Work for the purposes of recommending payments nor Project Engineer's recommendation of any payment, including final payment, will impose responsibility on Project Engineer:
 - 1) to supervise, direct, or control the Work, or
 - 2) for the means, methods, techniques, sequences, or procedures of construction, or the safety precautions and programs incident thereto, or
 - 3) for Contractor's failure to comply with Laws and Regulations applicable to Contractor's performance of the Work, or
 - 4) to make any examination to ascertain how or for what purposes Contractor has used the money paid on account of the Contract Price.
- (v) Project Engineer may refuse to recommend the whole or any part of any payment if, in Project Engineer's opinion, it would be incorrect to make the representations to PWC outlined in this Section.

General Conditions (Rev 7/2023)

- (d) Project Engineer will recommend reductions in payment (set-offs) necessary in Project Engineer's opinion to protect PWC from loss because:
 - (i) the Work is defective, requiring correction or replacement;
 - (ii) the Contract Price has been reduced by Change Orders;
 - (iii) PWC has been required to correct defective Work or has accepted defective Work in accordance with these General Conditions;
 - (iv) PWC has been required to remove or remediate a Hazardous Environmental Condition for which Contractor is responsible; or
 - (v) Project Engineer has actual knowledge of the occurrence of any of the events that would constitute a default by Contractor and therefore justify termination for cause under the Contract Documents.

- (e) Payment Becomes Due:
 - (i) Twenty (20) Business Days after presentation of the Application for Payment to PWC with Project Engineer's recommendation, the amount recommended (subject to any PWC set offs) will become due, and when due will be paid by PWC to Contractor.

- (f) Reductions in Payment by PWC:
 - (i) In addition to any reductions in payment (set-offs) recommended by Project Engineer, PWC is entitled to impose a set-off against payment based on any of the following:
 - 1) PWC has incurred costs, losses, or damages on account of Contractor's conduct in the performance or furnishing of the Work, including but not limited to claims, costs, losses, or damages from workplace injuries, adjacent property damage, non-compliance with Laws and Regulations, and patent infringement;
 - 2) Contractor has failed to take reasonable and customary measures to avoid damage, delay, disruption, and interference with other work at or adjacent to the Site;
 - 3) Contractor has failed to provide and maintain required bonds or insurance;
 - 4) PWC has been required to remove or remediate a Hazardous Environmental Condition for which Contractor is responsible;
 - 5) PWC has incurred extra charges or engineering costs related to submittal reviews, evaluations of proposed substitutes, tests and inspections, or return visits to manufacturing or assembly facilities;
 - 6) the Work is defective, requiring correction or replacement;
 - 7) PWC has been required to correct defective Work or has accepted defective Work in accordance with the Contract Documents;
 - 8) the Contract Price has been reduced by Change Orders;
 - 9) an event that would constitute a default by Contractor and therefore justify a termination for cause has occurred;
 - 10) liquidated damages have accrued as a result of Contractor's failure to achieve Milestones, Substantial Completion, or Completion of the Project; or
 - 11) there are other items entitling PWC to a set off against the amount recommended.
 - (ii) If PWC imposes any set-off against payment, whether based on its own knowledge or on the written recommendations of Project Engineer, PWC will give Contractor immediate written notice stating the reasons for such action and the specific amount of the reduction, and promptly pay Contractor any amount remaining after deduction of the amount so withheld. PWC shall promptly pay Contractor the amount so withheld, or any adjustment agreed to by PWC and Contractor if Contractor remedies the reasons for

General Conditions (Rev 7/2023)

such action. The reduction imposed shall be binding on Contractor unless it duly submits a Change Proposal contesting the reduction.

- (iii) Upon a subsequent determination that PWC's refusal of payment was not justified, the amount wrongfully withheld shall be treated as an amount due and subject to interest as provided in the Contract Documents.

Section 12.02 Substantial Completion

- (a) When Contractor considers the entire Work ready for its intended use Contractor shall notify PWC and Design Engineer in writing that the entire Work is substantially complete and request that PWC acknowledge in writing that Contractor has met Substantial Completion.
- (b) Promptly after Contractor's notification, PWC, Contractor, and Design Engineer shall make an inspection of the Work to determine the status of completion. If PWC does not consider the Work substantially complete, PWC will notify Contractor in writing giving the reasons therefor. PWC shall thereafter submit to Contractor an initial draft of punch list items to be completed or corrected before final payment.
- (c) If Design Engineer considers the Work substantially complete, Design Engineer will deliver to PWC a preliminary certificate of Substantial Completion which shall fix the date of Substantial Completion. Design Engineer shall attach to the certificate a punch list of items to be completed or corrected before final payment. PWC shall have seven (7) Business Days after receipt of the preliminary certificate to make written objection to Design Engineer as to any provisions of the certificate or attached punch list. If, after considering the objections to the provisions of the preliminary certificate, PWC concludes that the Work is not substantially complete, PWC will, within fourteen (14) calendar days after submission of the preliminary certificate to PWC, notify Contractor in writing that the Work is not substantially complete, stating the reasons therefor.
- (d) At the time of receipt of the preliminary certificate of Substantial Completion, PWC and Contractor will confer regarding PWC's use or occupancy of the Work following Substantial Completion, review the builder's risk insurance policy with respect to the end of the builder's risk coverage, and confirm the transition to coverage of the Work under a permanent property insurance policy held by PWC. Unless PWC and Contractor agree otherwise in writing, PWC shall bear responsibility for security, operation, protection of the Work, property insurance, maintenance, heat, and utilities upon PWC use or occupancy of the Work.
- (e) After Substantial Completion the Contractor shall promptly begin work on the punch list of items to be completed or corrected prior to final payment and shall complete such items within the time specified by PWC. In appropriate cases Contractor may submit monthly Applications for Payment for completed punch list items, following the progress payment procedures set forth above.
- (f) PWC shall have the right to exclude Contractor from the Site after the date of Substantial Completion subject to allowing Contractor reasonable access to remove its property and complete or correct items on the punch list.

Section 12.03 Partial Use or Occupancy

- (a) Prior to Substantial Completion of all the Work, PWC may use or occupy any substantially completed part of the Work which has specifically been identified in the Contract Documents, or which PWC, Design Engineer, and Contractor agree constitutes a separately functioning and usable part of the Work that can be used by PWC for its intended purpose without significant interference with Contractor's performance of the remainder of the Work, subject to the following conditions:
 - (i) At any time PWC may request in writing that Contractor permit PWC to use or occupy any such part of the Work that PWC believes to be substantially complete.
 - (ii) At any time Contractor may notify PWC and Design Engineer in writing that Contractor considers any such part of the Work substantially complete and request Design Engineer to issue a certificate of Substantial Completion for that part of the Work.
 - (iii) Within a reasonable time after either such request, PWC, Contractor, and Design Engineer shall make an inspection of that part of the Work to determine its status of completion. If Design Engineer does not consider that part of the Work to be substantially complete, Design Engineer will notify PWC and Contractor in writing giving the reasons therefor.
 - (iv) No use or occupancy or separate operation of part of the Work may occur prior to compliance with the requirements regarding builder's risk or other property insurance.

Section 12.04 Final Inspection

- (a) Upon written notice from Contractor that Completion of the Project has been achieved or an agreed portion thereof is complete, PWC will promptly make a final inspection with Project Engineer, Design Engineer, and Contractor and will notify Contractor in writing of all particulars in which this inspection reveals that the Work, or agreed portion thereof, is incomplete or defective. Contractor shall immediately take such measures as are necessary to complete such Work or remedy such deficiencies.

Section 12.05 Final Payment

- (a) Application for Payment:
 - (i) After Contractor has, in the opinion of PWC, satisfactorily completed all corrections identified during the final inspection and has delivered, in accordance with the Contract Documents, all maintenance and operating instructions, schedules, guarantees, bonds, certificates or other evidence of insurance, certificates of inspection, annotated record documents, and other documents, Contractor may make application for final payment.
 - (ii) The final Application for Payment shall be accompanied (except as previously delivered) by:
 - 1) all documentation called for in the Contract Documents;
 - 2) consent of the surety, if any, to final payment;
 - 3) satisfactory evidence that all title issues have been resolved such that title to all Work, materials, and equipment has passed to PWC free and clear or will so pass upon final payment;
 - 4) a list of all disputes that Contractor believes are unsettled; and
 - 5) complete and legally effective releases or waivers (satisfactory to PWC) required by the Contract Documents.

General Conditions (Rev 7/2023)

- (iii) If Design Engineer is satisfied that the Work has been completed and Contractor's other obligations under the Contract have been fulfilled, Design Engineer will, within ten (10) Business Days after receipt of the final Application for Payment, indicate in writing Design Engineer's recommendation of final payment and present the Application for Payment to PWC for payment. Such recommendation shall account for any set-offs against payment that are necessary in Design Engineer's opinion to protect PWC from loss for the reasons stated above with respect to progress payments. At the same time Design Engineer will also give written notice to PWC and Contractor that the Work is acceptable and that Completion of the Project has been achieved. Otherwise, Design Engineer will return the Application for Payment to Contractor, indicating in writing the reasons for refusing to recommend final payment, in which case Contractor shall make the necessary corrections and resubmit the Application for Payment.
- (iv) Within thirty (30) calendar days after the presentation to PWC of the final Application for Payment and accompanying documentation, the amount recommended by Design Engineer (less any further sum PWC is entitled to set off against Design Engineer's recommendation, including but not limited to set-offs for liquidated damages and set-offs allowed under the provisions above with respect to progress payments) will become due and shall be paid by PWC to Contractor.

Section 12.06 Waiver of Claims

- (a) The making of final payment will not constitute a waiver by PWC of claims or rights against Contractor. PWC expressly reserves claims and rights arising from defective Work appearing after final inspection, from Contractor's failure to comply with the Contract Documents or the terms of any special guarantees specified therein, from Contractor's indemnification obligations, or from Contractor's continuing obligations under the Contract Documents.
- (b) The acceptance of final payment by Contractor will constitute a waiver by Contractor of all claims and rights against PWC other than those pending matters that have been duly submitted or appealed under the provisions of the Contract Documents.

Section 12.07 Correction Period

- (a) If within one (1) year after the date of Substantial Completion (or such longer period of time as may be prescribed by the terms of any applicable special guarantee required by the Contract Documents, or by any specific provision of the Contract Documents), any Work is found to be defective, or if the repair of any damages to the Site, adjacent areas that Contractor has arranged to use through construction easements or otherwise, and other adjacent areas used by Contractor as permitted by Laws and Regulations, is found to be defective, then Contractor shall promptly, without cost to PWC and in accordance with PWC's written instructions:
 - (i) correct the defective repairs to the Site or such other adjacent areas;
 - (ii) correct such defective Work;
 - (iii) if the defective Work has been rejected by PWC, remove it from the Project and replace it with Work that is not defective, and
 - (iv) satisfactorily correct or repair or remove and replace any damage to other Work, to the work of others, or to other land or areas resulting therefrom.
- (b) If Contractor does not promptly comply with the terms of PWC's written instructions, or in an emergency where delay would cause serious risk of loss or damage, PWC may have

General Conditions (Rev 7/2023)

the defective Work corrected or repaired or may have the rejected Work removed and replaced. Contractor shall pay all claims, costs, losses, and damages (including but not limited to all fees and charges of engineers, architects, attorneys, and other professionals and all court or arbitration or other dispute resolution costs) arising out of or relating to such correction or repair or such removal and replacement (including but not limited to all costs of repair or replacement of work of others).

- (c) In special circumstances where a particular item of equipment is placed in continuous service before Substantial Completion of all the Work, the correction period for that item may start to run from an earlier date only as provided in the Contract Documents.
- (d) Where defective Work (and damage to other Work resulting therefrom) has been corrected or removed and replaced under this Article XII, the correction period hereunder with respect to such Work will be extended for an additional period of one year after such correction or removal and replacement has been satisfactorily completed.
- (e) Contractor's obligations under this Article XII are in addition to all other obligations and warranties. The provisions of this Article XII shall not be construed as a substitute for, or a waiver of, the provisions of any applicable statute of limitation or repose.

Article XIII. Suspension of Work and Termination

Section 13.01 PWC May Suspend Work

- (a) At any time and without cause, PWC may suspend the Work or any portion thereof for a period of not more than 90 consecutive calendar days by written notice to Contractor and Design Engineer. Such notice will fix the date on which Work will be resumed. Contractor shall resume the Work on the date so fixed. Contractor shall be entitled to an adjustment in the Contract Price or an extension of the Contract Times, or both, directly attributable to any such suspension. Any Change Proposal seeking such adjustments shall be submitted no later than thirty (30) calendar days after the date fixed for resumption of Work.

Section 13.02 PWC May Terminate for Cause

- (a) The occurrence of any one or more of the following events will constitute a default by Contractor and justify termination for cause:
 - (i) Contractor's continued failure to perform the Work in accordance with the Contract Documents (including, but not limited to, failure to supply sufficient skilled workers or suitable materials or equipment or failure to adhere to the Progress Schedule);
 - (ii) Failure of Contractor to perform or otherwise to comply with a material term of the Contract Documents;
 - (iii) Contractor's disregard of Laws or Regulations of any public body having jurisdiction; or
 - (iv) Contractor's repeated disregard of the authority of PWC, Project Engineer, or Design Engineer.
- (b) If one or more of the events identified in Paragraph 13.02(a) occurs, then after giving Contractor (and any surety) ten (10) calendar days written notice that PWC is considering a declaration that Contractor is in default and termination of the Agreement, PWC may proceed to:
 - (i) declare Contractor to be in default, and give Contractor (and any surety) notice that the

General Conditions (Rev 7/2023)

- Contract is terminated; and
- (ii) enforce the rights available to PWC under any applicable performance bond.
 - (c) Subject to the terms and operation of any applicable performance bond, if PWC has terminated the Contract for cause, PWC may exclude Contractor from the Site, take possession of the Work, incorporate in the Work all materials and equipment stored at the Site or for which PWC has paid Contractor but which are stored elsewhere, and complete the Work as PWC may deem expedient.
 - (d) PWC may not proceed with termination of the Contract under Paragraph 13.02(b) if Contractor within seven (7) calendar days of receipt of notice of intent to terminate begins to correct its failure to perform and proceeds diligently to cure such failure and such efforts are agreed to by PWC.
 - (e) If PWC proceeds as provided in Paragraph 13.02(b), Contractor shall not be entitled to receive any further payment until the Work is completed. If the unpaid balance of the Contract Price exceeds the cost to complete the Work, including all related claims, costs, losses, and damages (including but not limited to all fees and charges of engineers, architects, attorneys, and other professionals) sustained by PWC, such excess will be paid to Contractor. If the cost to complete the Work including such related claims, costs, losses, and damages exceeds such unpaid balance, Contractor shall pay the difference to PWC. Such claims, costs, losses, and damages incurred by PWC will be reviewed by PWC as to their reasonableness and, when so approved by PWC, incorporated in a Change Order.
 - (f) Where Contractor's services have been so terminated by PWC, the termination will not affect any rights or remedies of PWC against Contractor then existing or which may thereafter accrue, or any rights or remedies of PWC against Contractor or any surety under any payment bond or performance bond. Any retention or payment of money due Contractor by PWC will not release Contractor from liability.
 - (g) The provisions of any applicable payment or performance bond shall govern over any inconsistent provisions of this Section.

Section 13.03 PWC May Terminate For Convenience

- (a) Upon seven (7) calendar days written notice to Contractor, PWC may, without cause and without prejudice to any other right or remedy of PWC, terminate the Contract. In such case, Contractor shall be paid for (without duplication of any items):
 - (i) completed and acceptable Work executed in accordance with the Contract Documents prior to the effective date of termination, including fair and reasonable sums for overhead and profit on such Work;
 - (ii) expenses sustained prior to the effective date of termination in performing services and furnishing labor, materials, or equipment as required by the Contract Documents in connection with uncompleted Work, plus fair and reasonable sums for overhead and profit on such expenses; and
 - (iii) other reasonable expenses directly attributable to termination, including costs incurred to prepare a termination for convenience cost proposal.
- (b) Contractor shall not be paid on account of loss of anticipated overhead, profits, or revenue, or other economic loss arising out of or resulting from such termination.

Section 13.04 Contractor May Stop Work or Terminate

- (a) If, through no act or fault of Contractor, (1) the Work is suspended for more than ninety (90) consecutive calendar days by PWC or under an order of court or other public authority or (2) PWC fails for sixty (60) calendar days to pay Contractor any sum finally determined to be due, then Contractor may, upon seven (7) calendar days written notice to PWC, and provided PWC does not remedy such suspension or failure within that time, terminate the Contract and recover from PWC payment on the same terms as provided in this Article.
- (b) In lieu of terminating the Contract and without prejudice to any other right or remedy, if PWC has failed for thirty (30) calendar days to pay Contractor any sum finally determined to be due, Contractor may, seven (7) calendar days after written notice to PWC, stop the Work until payment is made of all such amounts due Contractor, including interest thereon. The provisions of this paragraph are not intended to preclude Contractor from submitting a Change Proposal for an adjustment in Contract Price or Contract Times or otherwise for expenses or damage directly attributable to Contractor's stopping the Work as permitted by this paragraph.

Section 13.05 Morality

- (a) If, in the sole opinion of PWC, at any time Contractor or any of its owner(s) or employee(s) or agent(s) (each party, owner, employee, and agent is an "Actor") engages in any one or more actions that bring disrepute, contempt, scandal, or public ridicule to the Actor or subject the Actor to prosecution or offend the community or public morals or decency or denigrate individuals or groups in the community served by PWC or are scandalous or inconsistent with community standards or good citizenship or may adversely affect PWC's finances, public standing, image, or reputation or are embarrassing or offensive to PWC or may reflect unfavorably on PWC or are derogatory or offensive to one or more employee(s) or customer(s) of PWC, PWC may immediately upon written notice to Contractor terminate the Agreement, in addition to any other rights and remedies that PWC may have pursuant to the Contract Documents or at law or in equity.

Article XIV. Miscellaneous

Section 14.01 Additional General Terms and Conditions

- (a) Contractor shall be subject to any additional terms and conditions for this Project as set forth in the applicable Appendices as specific in the Agreement, which is incorporated by reference as if set forth word-for-word herein.

Section 14.02 Giving Notice

- (a) Whenever any provision of the Contract Documents requires the giving of written notice, it will be deemed to have been validly given if:
 - (i) delivered in person, by a commercial courier service or otherwise, to the individual or to a member of the firm or to an officer of the corporation for which it is intended;
 - (ii) delivered at or sent by registered or certified mail, postage prepaid, to the last business address known to the sender of the notice; or
 - (iii) sent to PWC or Contractor's designee(s) via email, with a confirmation of receipt.

Section 14.03 Computation of Times

- (a) When any period of time is referred to in the Contract by days, it will be computed to exclude the first and include the last day of such period. If the last day of any such period falls on a Saturday or Sunday or on a day made a legal holiday by the law of the applicable jurisdiction, such day will be omitted from the computation.

Section 14.04 Cumulative Remedies

- (a) The duties and obligations imposed by these General Conditions and the rights and remedies available hereunder to the parties are in addition to, and are not to be construed in any way as a limitation of, any rights and remedies available to any or all of them which are otherwise imposed or available by Laws or Regulations, by special warranty or guarantee, or by other provisions of the Contract Documents. The provisions of this paragraph will be as effective as if repeated specifically in the Contract Documents in connection with each particular duty, obligation, right, and remedy to which they apply.

Section 14.05 Limitation of Damages

- (a) With respect to any and all Change Proposals, Claims, disputes subject to final resolution, and other matters at issue, neither PWC nor Design Engineer, nor any of their officers, directors, members, partners, employees, agents, consultants, or subcontractors, shall be liable to Contractor for any claims, costs, losses, or damages sustained by Contractor on or in connection with any other project or anticipated project.

Section 14.06 No Waiver

- (a) A party's non-enforcement of any provision shall not constitute a waiver of that provision, nor shall it affect the enforceability of that provision or any other provision of the Contract Documents.

Section 14.07 Survival of Obligations

- (a) All representations, indemnifications, warranties, and guarantees made in, required by, or given in accordance with the Contract Documents, as well as all continuing obligations indicated in the Contract Documents, will survive final payment, completion, and acceptance of the Work or termination or completion of the Agreement or termination of the services of Contractor.

Section 14.08 Controlling Law

- (a) The Agreement shall be governed by the law of the State of North Carolina.

Section 14.09 Headings

- (a) Article and paragraph headings, numbers, and letters are inserted for convenience only and do not constitute parts of these General Conditions.

**DIVISION 1
01000 – SUPPLEMENTAL CONDITIONS**

GENERAL

These Special Conditions are intended to supplement and amplify the Technical Specifications and other requirements of this Contract. Where any article or item of the Contract Documents is modified or deleted by this document, the remaining unaltered provisions of that article, paragraph, subparagraph, or clause shall remain in effect. In the event of a conflict, these Special Conditions shall take precedence.

Unless otherwise noted, all items in these Special Conditions shall be considered incidental to the Work, and no additional payment will be made for costs associated with these items.

1. SUMMARY

This project consists of rehabilitation of existing sewer lift station wet wells throughout the Fayetteville Public Works Commission system. Work shall include repair and preparation of the concrete surface, preparation and painting of stairs and railings, preparation and painting of piping, miscellaneous electrical and mechanical repairs, bypass pumping, installation of the specified coating system, and all related work necessary to rehabilitate the sewer lift station wet wells, as described in these Contract Documents.

All work shall be done in accordance with PWC technical standards, specifications, and these Contract Documents.

2. ORDER OF PRECEDENCE

Except as may be otherwise specifically stated in these Contract Documents, the following order of precedence shall be adhered to for resolving any conflict, error, ambiguity, or discrepancy between the provisions of these Contract Documents:

1. Any addendum issued prior to the opening of Bids
2. The Construction Agreement
3. Section 01000 – Supplementary Conditions
4. Section 01025 – Measurement and Payment
5. Approved Contract Drawings
6. Fayetteville Public Works Commission Standard Details
7. Fayetteville Public Works Commission Technical Specifications
8. General Conditions of the Contract Documents

3. METHOD OF REHABILITATION

The base bid will be based upon utilizing an approved epoxy, epoxy mortar, or polyurethane lining system in accordance with PWC Standard Specification 02764 Lift Station Wet Well Lining. The lining system shall be installed on the ceiling, floor, and walls, from the ceiling/top of the wet well wall to the floor of the wet well. The Contractor shall sawcut the existing concrete walls and “tie-in” the lining. An approved epoxy coating system shall be applied to the metal stairs, landing and railings.

4. EXISTING CONDITIONS

The Public Works Commission cannot guarantee that all of the lift station wet wells scheduled for rehabilitation have been inspected prior to assigning to Contractor. If the lift station wet wells have been previously inspected by the Public Works Commission, copies of those inspection reports, pictures, and/or videos will be available for viewing prior to the Contractor commencing work. The Contractor shall schedule an appointment for viewing the information.

5. COATING OF METALS

An approved epoxy coating system shall be applied to the metal stairs, landing and railings. The coating system shall be installed in accordance with Specification Section 09810 – Glass Reinforced Epoxy and the requirements of this paragraph. The epoxy coating system that is applied to the metal stairs and landing shall provide adequate slip resistance by broadcasting sand into the coating system or back rolling a glass-flake reinforced epoxy coating. The Contractor shall coat a small area of the stairs and allow the Public Works Commission to inspect the coating for proper slip resistance prior to completely coating the metal stairs. The approved epoxy coating systems are as follows or an approved equal may be submitted:

Metal Stairs and Landing:

Surface Preparation: SSPC-SP 5 White Metal Blast Cleaning.

1st Coat: Tnemec Series 435 Perma-Glaze applied at 12.0-15.0 dry mils.

OR

Sherwin Williams Sher-Glass FF Epoxy applied at 12.0 – 15.0 dry mils

2nd Coat: Tnemec Series 435 Perma-Glaze applied at 12.0-15.0 dry mils with 30/50 mesh sand broadcast to rejection into wet Series 435.

OR

Sherwin Williams Sher-Glass FF Epoxy applied at 12.0 – 15.0 dry mils back rolled such that the glass flakes provide adequate slip resistance.

3rd Coat: Tnemec Series 435 Perma-Glaze applied at 6.0-8.0 dry mils as a lock coat over slip resistance.

6. COATING SYSTEM

The coating system to be used shall meet the specification and standards outlined in these Contract Documents. It will be the responsibility of the Contractor and coating manufacturer to have a Level 3 National Association of Corrosion Engineers (NACE) Inspector inspect each coat of the specified coating. Inspection reports are to be provided to the Fayetteville Public Works Commission within 48 hours of the inspection. The NACE Level 3 Inspector shall be a representative of the coating manufacturer.

7. CUSTOMER SERVICE

The Contractor is expected to make every effort to reduce the impact of their operation to the Fayetteville Public Works Commission's operation and maintenance of the water and sewer system, and the affected customers within the project area. Full cooperation and coordination with the Fayetteville Public Works Commission personnel and customers is expected. It is expected that the Contractor will promptly respond to any concerns voiced by residents and/or the Fayetteville Public Works Commission personnel, and make every effort to resolve them immediately. Should the Contractor be unable to resolve the issue, the Contractor shall promptly notify the Fayetteville Public Works Commission. Such notification shall include the person's name, address, nature of complaint, and the Contractor's proposed remedy. Providing exemplary customer service shall be incidental to this Contract, and no additional payment will be made for this service.

The Contractor at all times shall conduct the work in such a manner as to ensure the least obstruction to traffic practicable. The convenience of the general public and of the residents and businesses along and adjacent to the Work shall be provided for in a satisfactory manner, consistent with the operation and local conditions. The Contractor shall construct and maintain any necessary ramps, boardwalks, or other means to maintain pedestrian traffic. Costs for such work shall be incidental to the unit prices bid. The Contractor shall at all times cooperate with the public and merchants as affected by the construction operations and shall endeavor to maintain good public relations at all times.

The Contractor shall make every effort to minimize the impacts of their operation on the businesses and/or residents. The Contractor shall contact the business owners to determine the optimum time for conducting their operations. The Contractor shall schedule their operations to minimize the likelihood of equipment operating throughout the night and/or on weekends in residential areas. The Contractor shall remove their equipment from the yards of residents at the end of each work day. Equipment shall not be left in yards, overnight, or during weekends, unless the Contractor has specific written permission from the property owner.

The Contractor shall fully coordinate their operations and schedule with the Fayetteville Public Works Commission.

8. CUSTOMER NOTIFICATION

Whenever the customer's use of the sanitary sewer must be interrupted by the Work, the Contractor shall notify the customers a minimum of two (2) business days in advance of the interruption. This notification shall be accomplished with door hanger notification cards placed at the addresses of the affected customers. Customers shall be informed when service interruption takes place and the expected duration. The Contractor shall make every effort to minimize inconvenience to the public and customers.

Service interruptions to customers shall be limited to no more than eight (8) hours at any given time.

The notifications shall describe the work to be undertaken and approximate dates of the work. The notifications shall clearly indicate the dates and times of the work. The text of the notifications shall be approved by the Fayetteville Public Works Commission in advance. The

Contractor shall notify the Fayetteville Public Works Commission Project Coordinator each time such notification is issued to the customers.

9. RESIDENT NOTIFICATION OF WORK

The Contractor shall not enter back yards, fenced areas, or areas that may be deemed private or personal – regardless of easements or rights of way held by the Fayetteville Public Works Commission – without consent from the property owner and the Fayetteville Public Works Commission Project Coordinator. The Contractor shall coordinate with the Fayetteville Public Works Commission Project Coordinator to notify residents a minimum of one (1) week in advance of the need to work in these areas.

If there are assigned areas that will require the Contractor to access areas that are deemed private or personal (regardless of easements or rights-of-way held by PWC), the Contractor shall coordinate with the PWC Design Engineer to issue letters to the affected property owners. Those notification letters will be prepared and issued by PWC. The Contractor shall coordinate with PWC so that the letters may be sent a minimum of 30 days before beginning any work in the area. The Contractor shall coordinate their schedule with PWC so that the information provided in the notification letters is as accurate as possible. Once the schedule has been established, the Contractor shall continually update PWC and the affected property owners of any changes to that schedule.

Communication and coordination with PWC and the property owners is an expectation of this Contract and will be used as a basis for determining if the Contract should be renewed. PWC prides itself on being customer oriented and it is the expectation that the Contractor will keep the customers (property owners) fully informed of their schedule.

10. WORKING TIMES

The Contractor shall limit their operations to Monday through Friday, between the times of 8:00 am and 6:00 pm, unless otherwise approved by the Fayetteville Public Works Commission. The Contractor shall plan their daily activities in order to ensure that all work is completed by 6:00 pm. This provision will be strictly enforced by the Fayetteville Public Works Commission.

11. CLEANLINESS DURING CONSTRUCTION

Failure of the Contractor to maintain a clean site will be basis for the Fayetteville Public Works Commission to issue a written notice of non-compliance with the Contract. Should that notice to correct not be complied with within twenty-four (24) hours, the Fayetteville Public Works Commission may authorize the cleanup to be performed by others and the costs shall be deducted from monies due the Contractor. The Contractor shall legally dispose off-site all waste materials and other excess materials resulting from the Work. No separate payment shall be made for maintaining a clean project site.

12. SPILL RESPONSE

The Contractor shall not discharge or pump any sewage, solids, or debris on the ground, streets, storm water system, ditches, or streams. Any sewage spills shall be immediately reported to the PWC Water Resources Construction Department, (910) 223-4716. After

normal business hours, the Contractor shall contact the PWC Dispatch Center, (910) 678-7400.

In the event that raw sewage is spilled, discharged, leaked or otherwise deposited in the open environment, due to the Contractor's work, the Contractor is responsible for any cleanup of solids and disinfection of the area affected. This work will be performed at the Contractor's expense with no additional cost to the Public Works Commission. The Contractor is also responsible for complying with any and all regulatory requirements in regards to the size spill with no additional cost to the Public Works Commission. The Contractor shall cooperate fully with the Public Works Commission and the applicable State agencies in responding to and cleaning up the spill. Any work completed by the Public Works Commission in responding to a spill caused by the Contractor's operations shall be billed to the Contractor.

Where sewage has backed up into a property due to the Contractor's failure to reopen a lateral properly or expeditiously or other aspect of the Contractor's operation, the Contractor shall immediately notify the Public Works Commission, inspect the property with the Public Works Commission and agree on remedial measures. The Contractor shall be responsible for all cleaning, repair and / or replacement of damaged property, temporary relocation of all occupants of the affected properties, if required, all to the satisfaction of the property owner. These actions shall be undertaken immediately upon learning of the backup. Cleaning shall be performed by firms specializing in this type of work. All costs associated with the cleaning, repair, replacement of damages, occupant accommodations, insurance and spill remediation shall be borne by the Contractor. All remediation measures required as part of a spill response are part of acceptance of the project, and final payment shall not be made until such time all required measures are addressed and approved by the appropriate regulatory agency.

13. OFFICE FACILITIES

The Contractor shall provide at his expense telecommunications via cellular phone at all times on the job site. The Project Superintendent must be onsite and accessible by telephone at all times while work is progressing. The Project Superintendent shall have access to plans, contract documents, permits, and encroachment agreements at all times whether an office facility is provided by the Contractor or not.

14. PROJECT SCHEDULE

Each week, the Contractor shall provide (via email) the Fayetteville Public Works Commission with their schedule for the upcoming week. The Contractor shall contact the Fayetteville Public Works Commission Project Coordinator on a daily basis, to confirm their schedule for that day. The Contractor shall immediately notify the Fayetteville Public Works Commission of any deviations to their schedule. Failure to notify the Fayetteville Public Works Commission of any deviations may result in payment being withheld.

15. CONTRACTOR'S DUTY AND OBLIGATION TO THE PUBLIC

The Contractor at all times shall conduct the work in such a manner as to ensure the least obstruction to traffic practicable. The convenience of the general public and of the residents and businesses along and adjacent to the street(s) shall be provided for in a satisfactory manner, consistent with the operation and local conditions. The Contractor shall construct and maintain any necessary ramps, boardwalks, or other means to maintain pedestrian traffic. Costs for such work shall be incidental to the unit prices bid. The Contractor shall at all times

cooperate with the public and merchants affected by the construction operations and shall maintain good public relations at all times.

The Contractor shall schedule and stage construction in a sequence to minimize disruption to the largest number of residents/businesses for the shortest period of time. Special considerations shall be given to the neighborhood solid waste and trash collection schedule, mail delivery, and bus routes, if applicable.

16. PUBLIC SAFETY

The Contractor shall barricade all work, roads, etc. to keep the public away from the construction. The Contractor shall provide protection to all portions of the Work when the work is not in progress. The Contractor shall provide and install all measures necessary to protect the public. Damage due to the lack of proper protection shall be the Contractor's sole responsibility.

The Contractor and subcontractors shall be responsible for any damage to any Owner's property, private property, or property owned by other utilities. The Contractor shall repair all damage to as good as or better than existing conditions. The Contractor and subcontractors shall be responsible for and pay any claims.

17. JOBSITE REQUIREMENTS

In addition to requirements outlined in these Contract Documents, the following are mandatory requirements that will be strictly enforced:

- Posted speed limits shall be strictly adhered to. No speeding.
- Driveways shall not be blocked without prior notification and coordination with the resident.
- To the maximum extent possible, one lane of traffic shall be maintained at all times.
- Excess soil, stone, equipment, materials, etc. in the road or along the right-of-way shall be removed at the end of each workday. Soil, stone, millings, pipe, etc., shall not be stored or stockpiled in the road right-of-way.
- All trenches, excavations, or other hazards in the vicinity of the work shall be well barricaded and properly lighted at night.
- Mailboxes and traffic signs shall be only removed as necessary to facilitate the installation of the Work and shall be reinstalled during the same day of removal. Any damages to mailboxes, signs or posts shall be repaired by the Contractor at no cost to the Owner.
- Portable toilets shall be provided for workers. These facilities shall be placed discretely out of public view, kept clean, and orderly.
- Contractor(s) shall not enter onto private property for the purpose of using water or electricity without the written permission of the property owner.
- The use of profane or abusive language or obscene gesturing by workmen will not be tolerated and will be just cause for immediate dismissal from the project site as directed by the Owner or its authorized representative.
- OSHA safety measures are to be maintained at all times.
- An English-speaking Contractor's representative is required for each separate work crew.
- Do not litter at any time.

- Respond to all complaints within 24 hours.
- Wear proper protective clothing (hard hats, shoes, shirts, etc.). Personnel must wear an approved safety vest at all times while working on the Owner's project.
- During the installation of the utilities, the excavated material may be temporarily stockpiled adjacent to the work area. In no case shall stockpiled material be allowed to remain for a period of time exceeding the workday.
- The trench shall be completely backfilled at the end of each workday.
- If construction is temporarily halted during the workday, the open trench shall be manned continuously.
- Damage to sod and/or grass along the street right-of-way due to (but not limited to) temporarily stockpiled material, construction travel and other construction related activities shall be replaced with sod at the Contractor's sole expense.

18. SUBCONTRACTORS

The proposed lining method shall be completed by the prime contractor utilizing its own equipment and labor forces. The lining superintendent shall be an employee of the prime contractor.

Second tier subcontractors shall not be allowed. Violation of this provision of the Contract may be deemed a breach of the Contract.

19. STORED MATERIALS

There will be no payment for stored materials on this project.

20. GUARANTEE

All work completed under these Contract Documents shall be guaranteed by the Contractor for a period of five (5) years from the date of final acceptance. During that period, all serious defects discovered in the work, as determined by the Fayetteville Public Works Commission, shall be removed and replaced in a satisfactory manner by the Contractor at no cost to the Fayetteville Public Works Commission. The Fayetteville Public Works Commission may conduct an independent television inspection, at their sole expense, of the lining work prior to the completion of the five (5) year guarantee period.

Should the Fayetteville Public Works Commission's inspection determine that the liner is not in accordance with these Contract Documents; the Contractor shall mobilize and make all necessary repairs (including bypass, access, etc.) at no expense to the Fayetteville Public Works Commission. The Contractor will receive written notification from the Fayetteville Public Works Commission, and be allowed the chance to review the inspection documentation. The Contractor shall respond to the Fayetteville Public Works Commission with a plan of action within 30 calendar days of receiving notification. Alternatively, the Fayetteville Public Works Commission reserves the right to contract with another party to complete the warranty work, at the sole expense of the Contractor.

21. PRE-CONSTRUCTION VIDEO

The Contractor shall complete a pre-construction video inspection of the project area, to document pre-existing conditions. The video shall be submitted to the Fayetteville Public Works Commission on a standard portable digital media as outlined in these Contract

Documents. The intent of this video is to document the roadside and/or easement conditions, easement areas, the driveways, the condition of the curb and gutter, the condition of the mailboxes, retaining walls, fences and gates, any other resident installed improvements, and the condition of the sod. The Contractor shall include any easement areas, especially those passing through yards, driveways, etc. The video must identify the house number and the street name in the audio track and visually. The Contractor may also include any pre-existing conditions they want brought to the attention of the Fayetteville Public Works Commission Project Engineer by including notes and time position on the index sheet. The Contractor can also include still pictures of the areas, for additional documentation. The video and any other accompanying data shall be submitted to the Fayetteville Public Works Commission Project Engineer before any work can commence. The Contractor shall furnish copies of the video inspection in a standard digital video file format (mp4 or avi) and on a standard portable digital media (USB Flash Drive or USB Hard Disk Drive) to the Fayetteville Public Works Commission.

22. BYPASS PUMPING

Bypass pumping shall be in accordance with Specification Section 02750 – Wastewater Flow Control and the following.

The Contractor shall schedule a coordination meeting with the Fayetteville Public Works Commission and other personnel (Contractor, bypass sub-contractor, etc.) a minimum of three (3) business days prior to starting the temporary bypass pumping system. The purpose of this coordination meeting is to ensure that the Contractor and their sub-contractors have a good understanding of the requirements and expectations of operating the temporary bypass pumping system, discuss contingency plans (to include protocols for emergency contacts), identify location(s) of pumps, verify necessary materials (repair sleeves, containment devices, etc.) are on-site and available, and any other items necessary to ensure that the Fayetteville Public Works Commission has confidence that the appropriate personnel can operate and maintain the temporary bypass pumping system. Should, for any reason, the Fayetteville Public Works Commission deem that the Contractor and/or their sub-contractor is not prepared to operate and maintain the temporary bypass pumping system, the temporary bypass pumping system shall not be started. The Contractor shall take all necessary steps to address any concerns to the satisfaction of the Fayetteville Public Works Commission. Upon completion of those actions, another coordination meeting shall be held, in order for the Fayetteville Public Works Commission to confirm that the Contractor and their sub-contractor is prepared to operate and maintain the temporary bypass pumping system. This process will be repeated until the Fayetteville Public Works Commission is satisfied that the Contractor and their sub-contractor are prepared to operate and maintain the temporary bypass pumping system.

23. LIMITS OF CONSTRUCTION

The Contractor shall confine their rehabilitation operations (bypass, access, etc.) to the existing permanent easement (typically 20 feet, centered on the sewer main) or the existing street rights-of-way. The Contractor shall coordinate with the Fayetteville Public Works Commission to confirm the size and location of the existing permanent easement(s).

The Contractor may use additional area for staging, storage or other operations, provided that written permission is obtained from the property owner and all disturbed areas are restored to conditions equal to or better than existing.

24. STAGING AREAS

The Contractor shall be required to secure staging areas for storing materials, equipment, etc. All costs, such as rent, restoration, erosion control measures, and permit fees shall be the responsibility of the Contractor. The location and operation of the staging yard shall comply with all applicable Federal, State, and local regulations.

All staging areas will be subject to inspection by the Fayetteville Public Works Commission, or agents thereof, for compliance with this section without prior notice. Any deficiencies will be documented by Fayetteville Public Works Commission and written notice will be given to the Contractor in accordance with these Contract Documents. The Contractor shall rectify any deficiencies in a reasonable time frame. Failure to do so will result in breach of contract.

The Contractor will submit a Staging Area Operation Plan for each site consisting at a minimum of the following:

- The layout of each staging area clearly identifying use areas and sufficient in detail and scale to indicate the proximity of activity to adjacent residences and businesses;
- Transportation plan including routes for both ingress and egress;
- Dust control measures both on site and along transportation routes necessary to minimize the transmission of material onto streets used for ingress and egress;
- Fuel and hazardous material storage and management. Total secondary containment, shall be used for fuel and liquid hazardous materials storage and to prevent spillage.
- Hours of operation and noise mitigation measures.
- Application and Fee for the Temporary Use Permit.
- Application and Fee for Truck Route Permit.

The Contractor shall obtain a signed agreement for the staging area in accordance with the General Conditions of these Contract Documents. Upon the completion of the project the Contractor shall obtain a signed release from the property owner for the satisfactory completion and restoration prior to issuance of final payment.

25. AGREEMENTS WITH PROPERTY OWNERS

Any and all agreements between the Contractor and individual property owners for work (to included access for bypass pumping and/or piping), services, rent of staging areas, etc. located outside of any easements or public rights-of way shall not obligate the City of Fayetteville or the Fayetteville Public Works Commission in any manner. Prior to performing any work on private property, which could remotely infer the Contractor acting on behalf of the Fayetteville Public Works Commission, the Contractor shall furnish to the Fayetteville Public Works Commission a signed and witnessed statement executed by the property owner acknowledging that the City of Fayetteville and the Fayetteville Public Works Commission are not liable for any agreements between the property owner and the Contractor, and that the Contractor shall hold harmless and defend the City of Fayetteville and the Fayetteville Public Works Commission from all claims, damages, etc. Additionally, all agreements/actions by Subcontractors shall be the Contractor's responsibility to secure the property owner's agreement as described herein.

Prior to release of final payment, the Contractor shall obtain written releases from the property owners for satisfaction, completion, and restoration. Copies of those written releases shall be submitted to Fayetteville Public Works Commission with the final pay application.

The Contractor bears complete responsibility for any damage to private properties outside of the permanent easements and/or rights-of-way.

26. ACCESS

The Contractor shall be responsible for constructing the necessary access needed to complete the project as outlined in these Contract Documents. The Contractor shall confine their access requirements to public rights-of-way or permanent easements, wherever possible. The Fayetteville Public Works Commission will provide assistance in attempting to gain permission to cross private property, in the event it is necessary. The Contractor shall coordinate with the Fayetteville Public Works Commission a minimum of two (2) weeks in advance, in order to gain such access.

Prior to completing any work on private property that is outside of a permanent easement, the Contractor shall obtain an agreement with that property owner. Further, the Contractor shall complete a pre-construction video inspection of the property. It is recommended that the pre-construction video document existing conditions of the areas adjacent to the proposed work area.

All access that is constructed on private property shall be removed and the property restored to existing or better condition than before construction commenced. The Contractor shall be responsible for obtaining a signed release from the affected property owner(s), stating that the property has been satisfactorily restored. Final payment shall not be released until all signed releases are obtained and submitted to the Fayetteville Public Works Commission.

Access constructed in permanent easements shall remain, unless otherwise instructed by the Fayetteville Public Works Commission.

The Fayetteville Public Works Commission shall be responsible for clearing the existing permanent easement right-of-way, should it be necessary. The Contractor shall provide the Fayetteville Public Works Commission with a minimum of two (2) weeks notice for any easement clearing.

27. GATE ACCESS

The Fayetteville Public Works Commission has several locations where gates and fences have been installed across permanent utility easements. The Contractor may utilize the gate(s) for access to the proposed sanitary sewer manholes to be rehabilitated. The Contractor shall furnish their lock to facilitate access. The Contractor shall inter-lock their lock with the Fayetteville Public Works Commission lock, to ensure that either can gain access to the easement without the other being present. The gate shall be locked at the end of each workday, or whenever there is no activity in that area. The Contractor shall coordinate with the PWC Project Coordinator for inter-locking any gate(s). The Contractor shall remove their lock upon completion of the work.

28. MANHOLE COVERS

For all manholes in streets, the Contractor shall secure the covers to the rings to reduce rattling. The Contractor shall apply four (4) dollops of roofing tar to the frame, to eliminate the cover from rattling. The dollops shall be equally spaced around the frame to the ring utilizing four dollops approximately the size of a quarter, each spaced 90 degrees around the ring. The roofing tar shall be applied upon completion of the pre-rehabilitation cleaning and video inspection, as well as upon completion of the post-rehabilitation inspection. The Fayetteville Public Works Commission Project Coordinator shall verify that the manholes are properly sealed and do not rattle. The cost for this work is considered incidental, and no separate payment will be made.

For manholes located in easement areas, the Contractor shall secure the covers at all times. For those manholes that are water-tight with a locking ring and cover (cam-lock), those manholes shall be locked whenever the Contractor leaves that particular manhole. **In no circumstance shall a manhole cover be left uncovered and/or unlocked when the Contractor leaves the site.**

Contractors shall ensure that their subcontractors are aware of and in compliance with these requirements.

This provision will be strictly enforced by the Fayetteville Public Works Commission.

In the event that a manhole cover does not seat and/or lock properly, the Contractor shall immediately notify the Fayetteville Public Works Commission Project Coordinator.

29. COORDINATION OF WORK

The Contractor shall maintain unobstructed access to all areas for other contractors at all times. The Contractor will be required to conduct their operations in a manner that will not interfere with or damage work that is being performed by others. The Contractor shall keep other contractors informed of any necessary operations or activities that may interfere with their work. The Contractor shall plan, schedule, and coordinate his operations in a manner which will facilitate the simultaneous progress of work in adjacent areas and any additional work being performed by others on or adjacent to the site.

Any conflicts or interference that cannot be resolved through direct communication with other contractors working on the site shall immediately be brought to the Fayetteville Public Works Commission Project Coordinator's attention for resolution. The Fayetteville Public Works Commission Project Engineer's decisions regarding resolution of conflicts between contractors shall be final and binding on all parties. The Contractor shall not claim extra compensation for delays or hindrances caused by other contractors unless such delays or hindrances are clear violations of prior coordination agreements.

30. PROTECTION OF SANITARY SEWER SYSTEM

The Contractor shall take all necessary precaution to guard against any or all damage to existing structures, pipe lines, and equipment of the Fayetteville Public Works Commission. Any damage to existing structures, pipe lines, or equipment resulting from the Contractor's operations shall be the Contractor's responsibility to repair/replace prior to proceeding with

the rehabilitation work. All repairs shall be in accordance with the Fayetteville Public Works Commission standards.

The Contractor shall prevent debris and other items from their rehabilitation efforts from entering the sewer system. Damage to Fayetteville Public Works Commission facilities resulting from the Contractor's failure to control debris and/or other items related to their operation shall be the sole responsibility of the Contractor.

In the event any debris or other item from their operation enters the sewer system, the Contractor shall ***immediately*** contact the Fayetteville Public Works Commission. The Contractor shall then commence efforts to capture that debris at the downstream manholes. The Contractor shall continue to search for and recover any debris until either all debris is captured or instructed otherwise by the Fayetteville Public Works Commission. Any costs incurred by the Fayetteville Public Works Commission to help search for and/or retrieve the debris shall be the responsibility of the Contractor.

31. DAMAGE TO EXISTING UTILITIES

The Contractor shall take every precaution to guard against any damage to existing structures, pipelines, and/or equipment of the utility owner. Any damage to existing structures and/or pipelines shall be the direct responsibility of the Contractor. Damage shall be replaced and/or repaired by the Contractor as directed by the utility owner, or the value of such deducted from any monies due the Contractor under this Contract.

The utility owner shall supervise the Contractor's operation of all valves, gates, and other equipment. Except in case of emergency, the Contractor shall notify the utility owner a minimum of two (2) business days in advance of the need for operation of valves, gates, and other equipment necessary to allow the work to progress.

The Contractor shall notify the utility owner and the PWC Project Coordinator a minimum of 48 hours in advance to coordinate any proposed service interruption. If an unscheduled service interruption occurs, the Contractor shall immediately notify the utility owner and the PWC Project Coordinator. The Contractor shall immediately commence repairs in accordance with the utility owner's standards.

32. SANITARY SEWER FLOW MONITORS

The Fayetteville Public Works Commission maintains a network of 44 permanent flow monitors within the sanitary sewer system. In addition to the permanent flow monitors, the Fayetteville Public Works Commission may have several temporary flow monitors installed in various areas of the sanitary sewer system. In the event the Contractor encounters this equipment, they shall immediately contact the Fayetteville Public Works Commission Project Coordinator. The Fayetteville Public Works Commission will be responsible for the removal and reinstallation of the flow monitor equipment. Any damage to the flow monitor equipment resulting from the Contractor's operation shall be the responsibility of the Contractor.

33. REPLACEMENT OF FENCING

The Contractor is to replace any fencing disturbed as part of their operations for the work described within these Contract Documents. Fence re-setting is considered incidental to the operation, and no additional payment will be made for this work. In addition, if temporary fencing is requested by a property owner, the Contractor shall provide such fencing as

necessary, at no additional cost to the Fayetteville Public Works Commission. Fences shall be removed, properly stored and replaced, using new items as required, to restore the item to the original condition or better.

It is noted that private fences may be located across or on the utility easement. It is expected that the Contractor will fully scope the proposed project area(s) prior to commencing work, in order to conduct the work with minimal disruption and fence removal. The Contractor shall have the primary responsibility to coordinate access across private property.

34. EROSION AND SEDIMENTATION CONTROL

The provisions of Chapter 139, North Carolina General Statutes, as amended, shall be applicable to this project. The Contractor shall progressively adjust and/or add erosion control measures to complement their type of construction to prevent erosion and the transmittal of silt. All necessary erosion control measures shall be installed prior to any work. The installed erosion control measures shall remain serviceable until the site is restored and stabilized. Upon such time (which may be after completion of the project), the Contractor shall remove all temporary measures.

All fees, penalties, fines for non-compliance and all civil actions resulting there from shall be the Contractor's responsibility and shall in no way involve the Fayetteville Public Works Commission. The Contractor shall immediately notify the Fayetteville Public Works Commission of any fine, penalty, or notice of non-compliance by the North Carolina Department of Environmental Quality (NCDEQ). The Contractor may be required to modify or supplement the measures at no additional cost to the Fayetteville Public Works Commission.

In addition to installing and maintaining the appropriate erosion control devices, the Contractor shall maintain a neat and clean jobsite. The Contractor shall take the necessary measures to minimize dust, ensure the streets are clean and free of debris, and other measures as required. The Contractor shall maintain the proper erosion control devices to ensure against erosion. The Contractor shall ensure that the catch basin and inlet protection devices are free of dirt and debris.

Permanent and temporary erosion control measures proposed by the Contractor for staging areas, haul roads, bypass lines, etc. shall be at the Contractor's expense and shall not constitute additional compensation.

35. SITE RESTORATION AND CLEANUP

Upon completion of a section of work, the project location shall be cleaned up and grounds restored to the conditions that existed prior to commencing work. All restoration work shall be completed prior to commencing another section of work. Restoration includes, but is not limited to, seeding, mulching, placement of sod, replacement of fences, and patch paving. In those areas where an established stand of grass is disturbed due to the construction activities, the Contractor shall restore that area with sod. All other non-paved areas shall be seeded and mulched.

Surplus material, tools, and temporary structures shall be removed by the Contractor. All dirt, rubbish, and other debris from the operation shall be removed and legally disposed of by the Contractor, at no additional cost to the PWC.

The Contractor is to replace any fencing disturbed as part of their operations. Replacement of fencing is considered incidental to the operation, and no additional payment will be made for this work. In addition, if temporary fencing is required, the Contractor shall provide such fencing as necessary, at no additional cost to the PWC. Fences shall be removed and replaced, using new materials as required, to restore the item to the original condition or better.

36. TRAFFIC CONTROL

Traffic control measures shall be in accordance with Specification Section 02500 – Traffic Control, and the following requirements. The Contractor shall provide any and all traffic safety measures as required to satisfy local, state, and federal highway requirements. The Contractor working in public rights-of-way on streets open to vehicular traffic shall be required to temporarily maintain traffic control devices to reduce unnecessary congestion and unsafe traffic conditions.

The Contractor shall be liable for any damages resulting from his negligence in using adequate work zone traffic control. Furthermore, the Fayetteville Public Works Commission reserves the right to stop any work for non-compliance.

The Contractor shall coordinate his activities so as to minimize disruption of traffic and inconvenience to residents and the general public. All such traffic control devices, traffic patterns and road closures shall be approved by the Town of Hope Mills, the City of Fayetteville and/or NCDOT.

The point of contact for the City of Fayetteville, NCDOT, and the Town of Hope Mills are:

Ramon Melendez (City): (910) 433-1090

Troy Baker (NCDOT): (910) 364-0601

Ira Petersen (Hope Mills): (910) 429-3383

Failure to provide and maintain adequate traffic control devices may result in the Fayetteville Public Works Commission's refusal to make payment until corrective measures are in place.

Improper signage and traffic control devices will not be allowed. The City of Fayetteville, NCDOT, the Town of Hope Mills, and/or the Fayetteville Public Works Commission reserves the right relocate and/or remove such non-conforming signs and devices, setup proper signage to ensure public safety and deduct all costs for these items which may be incurred by the Fayetteville Public Works Commission. The Contractor shall make no claim for such work performed.

No work on the individual streets shall start until all the traffic control devices required for the particular work activity have been installed in accordance with the approved traffic control plan.

37. CONFINED SPACE

Prior to entering manholes or other areas that are defined as confined spaces, the Contractor shall follow all requirements and procedures as outlined by the Occupational Safety and Health Administration's (OSHA) Confined Space Entry requirements. A confined space entry program shall be included as part of the Contractor's Safety Plan.

38. CHEMICAL USES

All constituents of concern used during project construction or furnished for project operation, whether herbicides, pesticides, disinfectant, polymer, reactant or of other classification, must show approval of either the Environmental Protection Agency or the USDA. Use of all such chemical and disposal of residues shall be in strict conformance with manufacturer's instructions.

39. HAZARDOUS COMMUNICATION PROGRAMS

Refer to Article 5, Paragraph 5.05 in Section 00700 – General Conditions.

The Contractor shall be responsible to provide and maintain SDS sheets at the job site at all times. The sheets shall be located in an easily accessible and prominently located area. If the Contractor encounters any materials considered or suspected of being hazardous, the Contractor shall immediately secure the area and contact the Project Engineer for further instructions.

40. DISPOSAL OF DEBRIS

Debris collected by the Contractor's cleaning efforts can be disposed of at the Fayetteville Public Works Commission's Rockfish Creek Water Reclamation Facility (WRF). The Fayetteville Public Works Commission will be responsible for the debris once it is received at the Rockfish Creek WRF. The Rockfish Creek WRF is located at the end of Tracy Hall Road, near the intersection of Old Wilmington Road and NC Highway 87. The Contractor shall bear all costs for transporting the debris to the disposal site.

The Contractor shall take all necessary precautions to prevent debris and other items related to their rehabilitation efforts from entering the sewer system.

41. EXCAVATION

The Contractor shall be responsible for utilizing all measures necessary to comply with the applicable OSHA regulations.

42. PROTECTION OF PROPERTY

Upon request from the property owner, the Contractor shall remove and set aside those plantings identified by the property owner. All plantings to be salvaged shall be placed at the edge of the existing easement. It will be the property owner's responsibility to re-plant those items saved.

Tree branches and ornamental shrubbery shall be temporarily tied back to avoid damage. Damage to trees shall be trimmed and treated with a tree dressing.

43. MONTHLY PROGRESS MEETINGS

The Contractor and Fayetteville Public Works Commission Project Engineer shall mutually establish a regular time to meet on a monthly basis, for the duration of the project. The meetings shall be held at the Fayetteville Public Works Commission complex at 955 Old Wilmington Road, and will generally last about an hour. The Contractor's superintendent or designated representative shall attend these meetings. The Contractor's representative shall be knowledgeable of the project, issues that need to be addressed, and be able to make binding decisions for the Contractor.

The purpose of the meeting is to discuss various project related items, including, but not limited to: safety concerns, overall project status and schedule, the Contractor's schedule for the upcoming month, issues that the Contractor and/or Fayetteville Public Works Commission Project Engineer need to address, viewing of pre and/or post lining videos, and any proposed or potential change orders.

The cost for the Contractor's representative to attend the monthly meetings shall be included in the unit prices bid.

44. BULK WATER USAGE

The Fayetteville Public Works Commission will allow the Contractor to use water from its existing water system. The Contractor shall utilize proper backflow prevention devices when obtaining water from the Fayetteville Public Works Commission's system. The Contractor shall contact the Fayetteville Public Works Commission's Environmental System Protection Department at 910-223-4699 to determine the required backflow prevention devices, and to obtain a bulk water permit. The bulk water permit is an annual permit, and must be kept current throughout the duration of this Contract. The Contractor shall be responsible for the annual permit fee. The Contractor shall provide documentation on the amount of water used for their operations, and provide a monthly statement to the Fayetteville Public Works Commission.

45. EMERGENCY RESPONSE

In the event an emergency occurs, the Contractor shall immediately notify the Fayetteville Public Works Commission's Project Coordinator and Project Engineer, and immediately commence repairs. If the Contractor is unable to contact the Fayetteville Public Works Commission's Project Coordinator and Project Engineer, the Contractor shall immediately contact the Fayetteville Public Works Commission Dispatcher (910-678-7400).

The Contractor shall have personnel available to respond and perform emergency work immediately. It is the Contractor's responsibility to immediately respond to any emergency. The Contractor shall immediately notify the Fayetteville Public Works Commission if their crews are unable to perform the emergency work or if assistance will be required from the Fayetteville Public Works Commission. Any work completed by the Fayetteville Public Works Commission may be billed to the Contractor.

The Contractor shall maintain a crew capable of performing emergency maintenance work 24 hours a day, seven (7) days a week, including all holidays. The Contractor shall provide phone numbers for at least three (3) individuals in responsible charge (capable of making company binding decisions) to be available 24 hours a day, seven (7) days a week, including holidays. The emergency phone numbers and responsible individual's names shall be furnished to the Fayetteville Public Works Commission.

46. SUBMITTALS

The Contractor shall not perform any portion of the Work requiring submittal and review until the respective submittal has been approved by the Fayetteville Public Works Commission. Work performed prior to review and acceptance shall be at the Contractor's risk.

The Contractor shall submit the following information to the Fayetteville Public Works Commission prior to commencing the first section of work. Unless the Contractor proposes

to install a different type of lining system, changes the installation process or deviates in any way from the initial submission, submittals are not required prior to starting work at each lift station.

The Contractor shall submit to the Fayetteville Public Works Commission one (1) set electronically (as an Adobe pdf) of all required submittal data for review and approval. The Contractor shall furnish, prior to use of the materials, satisfactory written certification of his compliance with the manufacturer's standards for all materials, conformance with the methods of the manufacturer, and accordance with all standards specified and referenced within these specifications.

The Contractor shall provide submittals, in accordance with the PWC General Condition, on but not limited to the following:

- Contractor's safety plan, including confined space program
- Proposed project schedule
- Contractor personnel emergency contact information
- Labor and equipment rates
- Sample property owner agreement (if applicable)
- Executed property owner agreement (if applicable)
- Pre-construction video and pictures
- Electrical conduit, fittings, junction boxes, receptacles, wire, switches and lights
- Pipe hangers
- PVC pipe
- Aluminum grating
- Stainless steel fittings, straps, hardware, etc.
- Lining Materials (polymeric coating, UV-resistant top coat)
- Cementitious materials (infiltration control, patching, base coat)
- NACE III Inspector
- Bypass Plan – in accordance with Specification Section 02750 – Wastewater Flow Control
- Warranty

The Contractor shall provide submittals on all lining materials and resins and shall furnish the manufacturers' certifications that all of the lining materials are in compliance with the specifications, codes, and standards referenced in these Contract Documents. The submittals shall include installation instructions and details of all component materials and construction methods.

All information contained within the submittals shall be in accordance with these Contract Documents. Facsimile (fax) copies of the submittals or re-submittals will not be acceptable.

47. RESIDENTIAL/COMMERCIAL COMPLAINTS

The Fayetteville Public Works Commission' Complaint Resolution Procedure shall be followed throughout the duration of the Contract. The Contractor is required to maintain good public relations and to provide timely notifications to residents so as to minimize inconvenience and complaints.

The Fayetteville Public Works Commission has an established protocol for addressing residents' complaints. The Contractor shall be responsible for familiarizing himself and his subcontractors with this protocol. During the course of the Work, the Contractor shall immediately respond to requests from the Fayetteville Public Works Commission to address resident complaints. The Contractor shall inform his personnel and subcontractor personnel that all complaint issues be directed to the Fayetteville Public Works Commission Project Coordinator and the Contractor's Superintendent. The Fayetteville Public Works Commission Project Coordinator shall be present in all meetings with residents. Should the Fayetteville Public Works Commission determine the Contractor(s) non-responsive in addressing complaints, the Fayetteville Public Works Commission reserves the right to withhold progress payments until the complaint has been satisfied. The Contractor shall immediately notify the Fayetteville Public Works Commission Project Coordinator of any complaint received.

48. CONTRACTOR CLAIMS FOR EXTRA COST

Should the Contractor consider that as a result of any instructions given in writing by the Fayetteville Public Works Commission Project Engineer, he is entitled to extra costs above that stated in the Contract; the Contractor shall give written notice to the Fayetteville Public Works Commission Project Engineer. The written notice shall be sent to the Fayetteville Public Works Commission Project Engineer within seven (7) calendar days after the occurrence of the event and the Contractor shall not proceed with the work affected until further advised, except in an emergency involving the safety of life or property. No claims for extra compensation will be considered unless the claim is made. Extra Work performed by the Contractor, not approved by the Fayetteville Public Works Commission Project Engineer in writing shall not be considered for payment.

The Contractor shall not act on instructions received by him from persons other than the Fayetteville Public Works Commission's Project Engineer and/or Project Coordinator. Any claims for extra compensation or extension of time on account of unauthorized instruction will not be honored. The Fayetteville Public Works Commission Project Engineer will not be responsible for misunderstandings claimed by the Contractor of verbal instructions which have not been confirmed in writing, and in no such case shall instructions be interpreted as permitting a departure from the Contract Documents unless such instruction is confirmed in writing by the Fayetteville Public Works Commission Project Engineer.

49. TESTING

The Contractor shall coordinate and fully cooperate with the Project Coordinator when scheduling testing. The Contractor shall provide a minimum of two (2) business days' notice when scheduling testing with the Project Coordinator. All testing shall be in accordance with these Contract Documents.

The Contractor shall provide all equipment, materials, personnel, and all means necessary to perform all testing and inspection at no additional cost to Fayetteville Public Works Commission.

50. MANHOLE ACCESS TOOL

The Fayetteville Public Works Commission shall provide the Contractor with a locking ring and cover access tool at the pre-construction meeting. It is the responsibility of the Contractor to return the access tool upon completion of the project. If the tool provided by the Fayetteville

Public Works Commission is misplaced/lost, the cost to replace it shall be the responsibility of the Contractor.

51. AVAILABILITY

The Contractor shall be capable of providing crews as needed to complete the work without undue delay and shall begin work within 15 calendar days from the written Notice to Proceed (NTP).

52. PERMITS

It is anticipated that no permits will be required to complete the work. However, this shall not relieve the Contractor from coordinating as necessary with the appropriate agency, especially in regards to traffic control. Should it be determined that a North Carolina Department of Transportation (NCDOT) encroachment is required, the Contractor shall promptly notify the Fayetteville Public Works Commission. The Fayetteville Public Works Commission and Contractor will coordinate as necessary to prepare the encroachment. The Fayetteville Public Works Commission shall be responsible for submitting the encroachment to NCDOT. The Contractor shall adhere to all requirements of the approved encroachment.

Bidders are hereby notified that obtaining a NCDOT encroachment could take 60 to 90 calendar days or more. Therefore, the Contractor shall notify the Fayetteville Public Works Commission in a timely manner to coordinate submission of an encroachment, so as not to delay the project. Failure of the Contractor to properly coordinate their schedule with the Fayetteville Public Works Commission shall not be the basis for any extensions of Contract Time or additional compensation.

In the event it is necessary to perform an excavation in a City of Fayetteville owned street, an Excavation Permit will need to be submitted. The Fayetteville Public Works Commission will furnish the permit application to the Contractor to complete. The Contractor shall return the completed application to the Fayetteville Public Works Commission, who will be responsible for submitting it to the City of Fayetteville. The Contractor shall keep a copy of the approved permit at the jobsite, and shall make it available to City of Fayetteville personnel. The Fayetteville Public Works Commission shall be responsible for paying any fees associated with the Excavation Permit.

53. COLLATERAL DAMAGE

All collateral damage shall be sodded back at the Contractor's expense. Collateral damage areas are locations where the Contractor's equipment, spoil piles, materials, etc., have disturbed lawns and other areas outside of their work. The Contractor shall not restore collateral damage locations with seed. Damaged trees shall be trimmed and treated with a tree dressing.

The Contractor shall not encroach beyond the limits of the Fayetteville Public Works Commission's property or rights-of-way. The Contractor shall be solely responsible for any damage to property resulting from failing to locate the limits of the Fayetteville Public Works Commission's property or rights-of-way prior to beginning construction.

54. CONTRACTOR'S RESPONSIBILITY FOR WORK

Until final acceptance by the Fayetteville Public Works Commission, the project site and all the Work shall be the responsibility of the Contractor. The Contractor shall take every precaution to prevent damage to the project site, Work, and the surrounding areas. It shall be the responsibility of the Contractor to address any damage or injury arising from their direct or indirect performance on this project. The Contractor shall be responsible for maintaining the project site at all times, as required by these Contract Documents. The Contractor shall also be responsible for ensuring that the Work is installed and maintained in accordance with these Contract Documents until accepted by the Fayetteville Public Works Commission. This paragraph does not supersede the requirements of the general warranty.

55. MATERIALS

All materials to be utilized are to be in new condition. Materials are to be stored in strict accordance with the manufacturer's directions. Materials are to be of the type and brand specified within these Contract Documents. **No alternative or substitute materials shall be considered prior to award of the Contract.**

The Contractor shall submit all requests to utilize materials other than specified to the Fayetteville Public Works Commission for review. The Contractor shall be responsible for providing all required documentation necessary for the Fayetteville Public Works Commission to review and make a determination if the substitute material meets the required specification. All information shall be submitted in accordance with Section 01300 – Submittals.

The Contractor will be responsible for providing documented proof that the proposed substitution has a proven record of performance when used in the intended application as confirmed by actual field test(s) or by successful installations. The Fayetteville Public Works Commission reserves the right to reject any such proposed changes or substitutions at their sole discretion, and is under no obligation to justify their decision.

56. WARRANTY AGAINST LICENSE AGREEMENTS

The Contractor shall warrant to the Fayetteville Public Works Commission that the equipment used on this Contract, where covered by patents or license agreements, is furnished in accordance with such agreements and that the prices included herein cover all applicable royalties and fees in accordance with such license agreements. The Contractor shall defend, indemnify, and hold the Fayetteville Public Works Commission harmless from and against any and all costs, loss, damage, or expense arising out of or in any way connected with any claim of infringement of patent, trademark, or violation of license agreement.

57. THIRD PARTY CLAIMS PROCEDURE

The Fayetteville Public Works Commission shall notify the Contractor of all potential claims related to the Work within seven (7) calendar days of receiving notification. Should the Contractor receive a potential claim related to the Work, the Contractor shall notify the Fayetteville Public Works Commission within seven (7) calendar days of receiving notification. The Contractor shall provide Claimant and Fayetteville Public Works Commission written response acknowledging receipt of the claim within seven (7) calendar days.

If the Contractor meets with the claimant about the claim, the Fayetteville Public Works Commission shall be present at all times. The Fayetteville Public Works Commission shall maintain a record of any claim received, and the steps taken to resolve. The Fayetteville Public Works Commission shall also concurrently investigate each case. The Contractor agrees to furnish the Fayetteville Public Works Commission any information regarding the claim, the actions which led to the claim and/or the investigation of the claim and agrees to indemnify and hold the Fayetteville Public Works Commission harmless for any damage arising out of said claims. The Contractor shall provide their proposed response to the Fayetteville Public Works Commission within 30 calendar days of receiving the claim. Upon receipt of the response the Fayetteville Public Works Commission and the Contractor will discuss and reach a mutual agreement of the response necessary to send to the Claimant within 15 calendar days. Once the agreement is made the Contractor shall make a formal written resolution to the claimant.

Failure to act in good faith or respond to a claim in the timelines established the Fayetteville Public Works Commission will constitute a lack of response by the Contractor, therefore validating the claim. The Fayetteville Public Works Commission will deduct the total amount of the claim from the monthly pay application. Failure to comply with the above requirements for resolving claims may, at the sole discretion of the Fayetteville Public Works Commission, result in Breach of Contract.

The Contractor is aware of the Fayetteville Public Works Commission's Contractor Related Claims Procedure and understands that it is the Fayetteville Public Works Commission's practice to pursue reimbursement/subrogation for any and all claims related expenses, which are incurred as a result of the Contractor's performance under this agreement and allowed within the applicable Statue of Limitations.

*** END OF SECTION ***

DIVISION 1

PERFORMANCE BOND

Date of Execution: _____

Name of Principal: _____

(Contractor)

Name of Surety: _____

Name of Contracting

Body: Fayetteville Public Works Commission, Fayetteville, N.C.

Amount of Bond: _____

PROJECT: LIFT STATION REHABILITATION

KNOW ALL MEN BY THESE PRESENTS, That We, the Principal and Surety above named, are held and firmly bound unto the above named Contracting Body, hereinafter called the Contracting Body, in the penal sum of the amount stated above the payment of which sum well and truly to be made, we bind ourselves, our heirs, executors, administrators, and successors, jointly and severally, firmly by these present.

THE CONDITION OF THIS OBLIGATION IS SUCH that whereas the Principal entered into a certain Contract with the Contracting Body, identified as shown above and hereto attached.

NOW, THEREFORE, if the Principal shall well and truly perform and fulfill all the undertakings, covenants, terms, conditions, and agreements of said Contract during the original term of said Contract and any extensions there of that may be granted by the Contracting Body, with or without notice to the Surety, and during the life of any Guaranty required under the Contract, and shall also well and truly perform and fulfill all the undertakings, covenants, terms, conditions, and agreements of any and all duly authorized modifications of said Contract that may hereafter be made, notice of which modifications to the Surety being hereby waived, then, this obligation to be void; otherwise to remain in full force and virtue.

IN WITNESS WHEREOF, the above bounded parties have executed this instrument under the several seals on the date indicated above, the name and corporate seal of each corporate party being hereto affixed, and these presents duly signed by its undersigned representative, pursuant to authority of its governing body.

Executed in _____ counterparts.

Witness:

(Proprietorship of Partnership)

By:

Title:

(Corporate Secretary or
Assistant Secretary, Only)

CONTRACTOR:

(Trade or Corporate Name)

By:

Title:

(Owner, Partner, Corporate President or
Vice-President, Only)
(CORPORATE SEAL)

Witness:

Countersigned:

(N.C. Licensed Resident Agent)

SURETY COMPANY:

(Surety Company Name)

By:

Title:

(Attorney in Fact)
(SURETY CORPORATE SEAL)

PAYMENT BOND

Date of Execution: _____

Name of Principal: _____
(Contractor)

Name of Surety: _____

Name of Contracting

Body: Fayetteville Public Works Commission, Fayetteville, N.C.

Amount of Bond: _____

PROJECT: LIFT STATION REHABILITATION

KNOW ALL MEN BY THESE PRESENTS, that We, the PRINCIPAL and Surety above named, are held and firmly bound unto the above named Contracting Body, hereinafter called the Contracting Body, in the penal sum of the amount stated above the payment of which sum well and truly to be made, we bind ourselves, our heirs, executors, administrators, and successors, jointly and severally, firmly by these presents.

THE CONDITION OF THIS OBLIGATION IS SUCH that whereas the Principal entered into a certain Contract with the Contracting Body, identified as shown above and hereto attached.

NOW THEREFORE, if the Principal shall promptly make payment to all persons supplying labor and material in the prosecution of the work provided for in said contract, and any and all duly authorized modifications of said contract that may hereafter be made, notice of which modifications to the Surety being hereby waived, then, this obligation to be void; otherwise to remain in full force and virtue.

IN WITNESS WHEREOF, the above bounded parties have executed this instrument under the several seals on the date indicated above, the name and corporate seal of each corporate party being hereto affixed, and these presents duly signed by its undersigned representative, pursuant to authority of its governing body.

Executed in _____ counterparts.

Witness:

CONTRACTOR:

(Proprietorship of Partnership)

(Trade or Corporate Name)

By:

By:

Title:

Title:

(Corporate Secretary or
Assistant Secretary, Only)

(Owner, Partner, Corporate President or
Vice-President, Only)
(CORPORATE SEAL)

Witness:

SURETY COMPANY:

(Surety Company Name)

By:

Countersigned:

Title:

(N.C. Licensed Resident Agent)

(Attorney in Fact)
(SURETY CORPORATE SEAL)

**POWER OF ATTORNEY
(ATTACH)**

**CERTIFICATE(S) OF INSURANCE
(Attach)**

NOTICE TO PROCEED

TO: _____

Date: _____

PROJECT: **LIFT STATION REHABILITATION**

You are hereby notified to commence work in accordance with the Contract dated _____, 2024, on or before _____, 2024, and you are to complete the WORK within the **contract period** thereafter. The date of final completion therefore is _____.

FAYETTEVILLE PUBLIC WORKS COMMISSION

BY: _____

Victoria McAllister

Procurement Manager

ACCEPTANCE OF NOTICE

Receipt of the above NOTICE TO PROCEED

is hereby acknowledged this the _____ day of _____, 2024.

(CONTRACTOR)

BY: _____

TITLE: _____

- END OF SECTION -

SECTION C - ADMINISTRATIVE PROVISIONS

***** THIS PAGE WAS INTENTIONALLY LEFT BLANK *****

DIVISION 1
01025 – MEASUREMENT AND PAYMENT

GENERAL

The purpose of this Section is to define the methods of measurement and payment for each of the unit prices and/or lump sum prices listed in the Bid Form, which are required to construct the Work.

The unit price and/or lump sum price bid shall be full compensation for the work required under each bid item, which shall include all incidental costs relative thereto. Certain items of work are specified and/or shown as a detail in the Contract Documents; bid prices shall include all items of work required to furnish and/or install each in accordance with the Project requirements, whether specifically stated or itemized in the Measure and Payment description.

No payment will be made for stored materials.

LUMP SUM PAYMENT ITEMS

L-1 MOBILIZATION AND DEMOBILIZATION

A mobilization pay item is included for all initial costs incurred prior to beginning work on this Contract, including permits, licenses, fees, insurance, bonds, etc., as well as to mobilize personnel and equipment. Payment will be made on a lump sum basis and one time only for the duration of a Contract period.

For each contract renewal, the Contractor shall submit invoices from the surety and insurance companies, verifying continued bonding and insurance coverage. Payment will be made for this expenditure, up to but no more than, the price bid for Initial Mobilization.

The Contractor will be paid only for mobilizing to the first project of the Contract or renewed Contract at the unit price bid. The Contractor will not be paid to mobilize from project to project.

L-2 TRAFFIC CONTROL & TRAFFIC PLAN

The lump sum price bid shall include all costs for the preparation and implementation of required traffic management plans, furnishing, installing and maintaining traffic control signage and devices, relocating or removing signs or other traffic control devices, replacement of street signs, any necessary traffic control devices related to bypass pumping (i.e., ramps, temporary driveways, etc.), and all other incidental work throughout the project site, throughout the project duration. The Contractor shall coordinate his activities so as to minimize disruption of traffic and inconvenience to residents and the general public. All such traffic control devices, signage, traffic patterns and road closures shall be approved by the City of Fayetteville and/or the North Carolina Department of Transportation (NCDOT).

Payment under the lump sum price bid shall be made on a monthly basis based on actual estimated percentage of work completed and maintained as determined by the Project Coordinator or Project Engineer.

Prospective bidders are advised that failure to provide and maintain adequate traffic control devices and/or signage may result in the Project Engineer's refusal to make payment until corrective measures are in place.

Improper signage and/or traffic control devices will not be allowed. The Town of Hope Mills, NCDOT, and/or PWC reserves the right relocate and/or remove such non-conforming signs and devices, setup proper signage to ensure public safety and deduct all costs for these items which may be incurred by PWC. The Contractor shall make no claim for such work performed.

L-3 CONTINGENCY

This line item shall be used only upon issuance of a written work order by PWC for work not included in other items. The amount paid will be negotiated as lump sum or unit price per each item of additional work. Any unused portion of the allowance remaining at the completion of the contract shall revert to PWC as a credit. PWC reserves the right to delete the allowance from the contract prior to award.

UNIT PRICE ITEMS

U-1 WET WELL CLEANING

Payment under this item shall include all costs related to the cleaning of the wet well and removal of all the debris. The Contractor shall be responsible for providing the necessary equipment to clean and remove debris from the lift station wet well. This requirement includes the use of vacuor trucks and other related equipment. Cleaning shall include pressure washing the area normally under water, the wet well walls and ceiling, clean-up of the debris removed as part of the wet well wall preparation, clean-up of debris resulting from sand-blasting mechanical equipment and proper disposal of the debris. The Contractor shall also be responsible for the removal of the following items: existing light fixtures, abandoned water lines, drain pipe hangers, hose reels, junction boxes, switches, receptacles, conduit, and wiring as required. Payment includes all necessary coordination, transportation, labor, equipment, materials, and incidentals necessary to complete the work. Removal of the existing coating and preparation of the wet well walls to be lined with the elastomeric coating shall be paid for under the line item "Rehabilitate Wet Well Utilizing an Elastomeric Lining".

U-2 REHABILITATE WET WELL UTILIZING AN ELASTOMERIC LINING

Measurement shall be based on the number of square feet the lining system is installed within the lift station wet well. Measurement shall be from the top of the wet well wall to the wet well floor. Payment will be made at the contract unit price per square foot. All work shall be in accordance with these Contract Documents. The work shall include lining of the wet well ceiling. The Contractor shall saw cut the existing concrete walls and "tie-in" the lining. The unit price shall include preparing the walls and concrete surfaces (including the ceiling) to be lined, access to the structure, proper containment, surface preparation, removal and disposal of all debris resulting from preparing the walls and surfaces, furnishing and installing all materials comprising the lining system (to include the cementitious base coat), inspection by Nace Level 3 coatings inspector, testing, and all

other labor, tools, materials, equipment and incidentals necessary to obtain a watertight, sealed wet well. Lining shall include all exposed concrete within the existing wet well (to include the ceiling) to the wet well floor.

U-3 PAINT PUMPS AND PIPING

Payment under this item shall include all costs related to sandblasting mechanical equipment (to include suction piping, hoist, ventilation duct work, etc.) as directed by PWC, as well as any surface preparation and painting of the mechanical equipment (pumps and piping) prior to and/or after installation. Payment includes all necessary coordination, labor, equipment, materials and incidentals necessary to complete the work. Clean-up of the sandblast media will be paid for under the line item "Wet Well Cleaning".

U-4 GROUT LEAKS UTILIZING AN INJECTION GROUT

Measurement shall be based on the number of gallons used to stop actively flowing leaks within the wet well that cannot be contained with hydraulic cement or other hand applied material. Payment will be made at the unit price bid per gallon as listed in the Proposal. Work to be performed under this bid item includes cleaning and preparation, including removal of unsound material, furnishing and installing the injection grout, and all clean-up and proper disposal of debris and excess material. The unit price shall include all labor, materials, equipment and other incidentals necessary to stop the leak prior to the installation of the lining system. In no case shall this line item be used without consent from PWC. The Contractor shall provide evidence that this line item is necessary. Upon approval from PWC, the Contractor may proceed with utilizing this line item.

U-5 BYPASS PUMPING

Bypass pumping shall be accomplished in accordance with PWC Standard Specification 02750 Wastewater Flow Control and as outlined in these Contract Documents. Measurement shall be based on the actual number of days that bypass pumping is in operation, in order to properly control the flow in the sewer main, so as to be able to clean, and/or install the specified lining system. Payment shall be made at the unit price bid per day that the bypass system is installed and operating. Payment shall be for all activities related to bypass pumping, including, but not limited to, pump mobilization and demobilization, attending bypass coordination meetings, manhole plugs, bypass lines, securing the bypass lines from damage (including but not limited to temporary fencing, berms, tie-downs, etc.), coordination with residents (to include obtaining access agreements), testing temporary bypass pumping system, cleaning the bypass lines, removal and installation of the bypass lines, continuous physical monitoring of the bypass system, maintenance of the bypass system, appropriate air release valves, spill prevention measures (fuel and sewer), any necessary restoration, fuel, lubricants, labor, equipment, and all other incidentals necessary to ensure that the pumping operation is accomplished in accordance with these Contract Documents.

*** END OF SECTION ***

**DIVISION 1
01300 – SUBMITTALS**

PART 1 -- GENERAL

1.01 THE REQUIREMENT

- A. This section specifies the means of all submittals. All submittals shall be submitted to the Fayetteville Public Works Commission. A general summary of the types of submittals and the number of copies required is as follows:

<u>Copies to Owner</u>	<u>Type of Submittal</u>
1	Construction Schedule
1	Progress Estimates
1	Shop drawings
1	Product samples
1	Certificates of compliance
1	Warranties

All submittals shall be submitted electronically in PDF format.

- B. All submittals shall be provided in accordance with this Section, and as outlined in Section 01000 – Special Conditions. The Contractor shall refer to other Specification Sections within these Contract Documents, to ensure that all submittal requirements are adhered to. No construction shall proceed until all required submittals have been reviewed and approved by the Fayetteville Public Works Commission. Any and all work performed prior to review and acceptance of the submittals by the Fayetteville Public Works Commission shall be at the Contractor's sole risk. Further, failure to comply with the requirements of this Section may be considered Breach of Contract, and grounds for termination.

1.02 SUBMITTAL PROCEDURES

- A. The Contractor shall transmit each submittal with a form acceptable to the Fayetteville Public Works Commission, clearly identifying the project and the Contractor, the enclosed material and other pertinent information specified in other parts of this section. The submittal shall identify variations from the Contract Documents and Product or system limitations which may be detrimental to successful performance of the completed Work.
- B. The Contractor shall revise and resubmit submittals as required, identifying all changes made since previous submittals. Resubmittals shall be noted as such.
- C. The Contractor shall distribute copies of reviewed submittals to concerned parties, with instructions to those parties to promptly report any inability to comply with provisions.

1.03 CONSTRUCTION SCHEDULE

- A. The Contractor shall prepare and submit construction schedules in accordance with Section 01310 – Construction Schedule and these Contract Documents.

1.04 SHOP DRAWINGS

- A. General: The Contractor shall submit for review shop drawings for concrete reinforcement, structural details, materials fabricated especially for this Contract, and materials for which such Drawings are specified (as outlined in these Contract Documents) or as specifically requested by the Fayetteville Public Works Commission.
- B. Shop drawings shall show the principal dimensions, weight, structural and operating features, type and/or brand of finish or shop coat, grease fittings, etc., depending on the subject of the Drawings.
- C. When so specified, or if considered by the Fayetteville Public Works Commission to be acceptable, the manufacturer's specifications, catalog data, descriptive matter, illustrations, etc. may be submitted for review in place of shop drawings. In such case, the requirements shall be as specified for shop drawings, insofar as applicable.
- D. The Contractor shall be responsible for the prompt submittal of all shop drawings so that there shall be no delay to the Work due to the absence of such Drawings. The Fayetteville Public Works Commission will review the shop drawings within 10 business days of receipt of such Drawings. Reviewed shop drawings will be returned to the Contractor by regular mail.
- E. Time delays caused by rejection of submittals are not cause for extra charges to the Fayetteville Public Works Commission or time extensions.
- F. Requirements: All shop drawings shall be submitted to the Fayetteville Public Works Commission through the Contractor. The Contractor is responsible for obtaining shop drawings from his subcontractors and returning reviewed Drawings to them. All shop drawings shall be prepared on standard size, 24-inch by 36-inch sheets, or smaller, as approved by the Fayetteville Public Works Commission. All Drawings shall be clearly marked with the name of the project, Fayetteville Public Works Commission, Contractor, and pay item to which the drawing applies. Drawings shall be suitably numbered and stamped by the Contractor. Each shipment of Drawings shall be accompanied by a letter of transmittal giving a list of the drawing numbers and the names mentioned above.
- G. Product Data: Where manufacturer's publications in the form of catalogs, brochures, illustrations, or other data sheets are submitted in lieu of prepared shop drawings, such submission shall specifically indicate the particular item offered. Identification of such items and relative pertinent information shall be made with indelible ink. Submissions showing only general information will not be accepted.
- H. Product data shall include materials of construction, dimensions, performance characteristics and capacities, etc.

- I. Sample Warranties: When warranties are called for, a sample of the warranty shall be submitted with the shop drawings. The sample warranty shall be the same form that will be used for the actual warranty.
- J. Work Prior to Review: No material or equipment shall be purchased, fabricated especially for this Contract, or delivered to the project site until the required shop drawings have been submitted, processed and marked either "APPROVED" or "APPROVED AS NOTED". All materials and Work involved in the construction shall be as represented by said Drawings.
- K. The Contractor shall not proceed with any portion of the Work for which the design and details are dependent upon the design and details of equipment for which submittal review has not been completed.
- L. Contractor's Review: Only submittals which have been checked and corrected should be submitted to the Contractor by his subcontractors and vendors. Prior to submitting shop drawings to the Fayetteville Public Works Commission, the Contractor shall check thoroughly all such Drawings to satisfy himself that the subject matter thereof conforms to the Drawings and Specifications in all respects. Drawings which are correct shall be marked with the date, checker's name and indications of the Contractor's approval, and then shall be submitted to the Fayetteville Public Works Commission; other Drawings submitted to the Fayetteville Public Works Commission will be returned to the Contractor unreviewed.
- M. Contractor's Responsibility: The review of shop drawings will be general and shall not relieve the Contractor of the responsibility for details of design, dimensions, etc., necessary for proper fitting and construction of the Work required by the Contract and for achieving the specified performance.
- N. Contractor's Modifications: For submissions containing departures from the Contract Documents, the Contractor shall include proper explanation in his letter of transmittal. Should the Contractor submit for review equipment that requires modifications to the structures, piping, layout, etc. detailed on the Drawings, he shall also submit for review details of the proposed modifications. If such equipment and modifications are accepted, the Contractor, at no additional cost to the Fayetteville Public Works Commission, shall do all Work necessary to make such modifications.
- O. Substitutions: Whenever a particular brand or make of material, equipment, or other item is specified, or is indicated in these Contract Documents, it is for the purpose of establishing a standard of quality, design, and type desired and to supplement the detailed specifications. Any other brand or make which, in the opinion of the Fayetteville Public Works Commission, is equivalent to that specified or indicated may be offered as a substitute subject to the following provisions:
 - a. Contractor shall submit for each proposed substitution sufficient details, complete descriptive literature, and performance data together with samples of the materials, where feasible, to enable the Fayetteville Public Works Commission to determine if the proposed substitution is equal.
 - b. Contractor shall submit certified tests, where applicable, by an independent laboratory attesting that the proposed substitution is equal.

- c. A list of installations (including contact information) where the proposed substitution is equal.
 - d. Where the acceptance of a substitution requires revision or redesign of any part of the Work, all such revision and redesign, and all new Drawings and details required therefore, shall be provided by the Contractor at his own cost and expense, and shall be subject to review of the Fayetteville Public Works Commission.
 - e. In all cases the Fayetteville Public Works Commission shall be the sole judge as to whether a proposed substitution is to be accepted. The Contractor shall abide by the Fayetteville Public Works Commission 's decision when proposed substitute items are judged to be unacceptable and shall in such instances furnish the item, or substitute, as specified. No substitute items shall be used in the Work without written acceptance of the Fayetteville Public Works Commission. The Fayetteville Public Works Commission reserves the right to reject any such proposed changes or substitutions at their sole discretion, and is under no obligation to justify their decision.
 - f. Acceptance of any proposed substitution shall in no way release the Contractor from any of the provisions of the Contract Documents.
- P. Complete Submittals: Each submittal shall be complete in all aspects incorporating all information and data required to evaluate the products' compliance with the Contract Documents. Partial or incomplete submissions shall be returned to the Contractor without review.
- a. Shop Drawing Distribution: The Contractor shall submit a minimum of five (5) copies of all shop drawings to the Fayetteville Public Works Commission for review. Shop drawings will be reviewed, stamped and distributed with the appropriate box checked either "APPROVED", "APPROVED AS NOTED", "NOT APPROVED" or "REVISE AND RESUBMIT". The Fayetteville Public Works Commission shall return three (3) copies to the Contractor and retain two (2) copies

If the Contractor requires additional copies of returned shop drawings, he shall include extra Drawings in his original submittal. The Fayetteville Public Works Commission will process the Drawings and return them to the Contractor.

1.05 PRODUCT SAMPLES

- A. Contractor shall furnish for review all product samples as required by the Contract Documents or requested by the Fayetteville Public Works Commission to determine compliance with the specifications.
- B. Samples shall be of sufficient size or quantity to clearly illustrate the quality, type, range of color, finish or texture and shall be properly labeled to show complete project identification, the nature of the material, trade name of manufacturer and location of the Work where the material represented by the sample will be used.
- C. Samples shall be checked by the Contractor for conformance to the Contract Documents before being submitted to the Fayetteville Public Works Commission and shall bear the Contractor's stamp certifying that they have been so checked. Transportation charges on samples submitted to the Fayetteville Public Works Commission shall be prepaid by the Contractor.

- D. Fayetteville Public Works Commission's review will be for compliance with the Contract Documents, and his comments will be transmitted to the Contractor within 15 business days of receipt.
- E. Acceptable samples will establish the standards by which the completed Work will be judged.

1.06 CERTIFICATES OF COMPLIANCE

- A. Copies of certificates of compliance and test reports shall be submitted for requested items to the Fayetteville Public Works Commission prior to request for payment.

1.07 WARRANTIES

- A. Original warranties, called for in the Contract Documents, shall be submitted to the Fayetteville Public Works Commission. When warranties are required for an item, the warranty shall be submitted prior to request for payment of that item.
- B. When warranties are requested, a sample of the warranty to be provided shall be submitted with, and considered part of, the shop drawings.
- C. The Contractor shall warrant to the Fayetteville Public Works Commission that all material and labor used in the construction are covered by his warrantee for a minimum of a one (1) year period upon approval and acceptance by the Fayetteville Public Works Commission. The Contractor shall replace or repair defects at no cost to the Fayetteville Public Works Commission during the warrantee period.

*** END OF SECTION ***

**DIVISION I
GENERAL REQUIREMENTS**

01310 – CONSTRUCTION SCHEDULE

GENERAL

1.01 WORK INCLUDED

- A. This section specifies requirements and procedures in preparing and updating construction schedules and reports for planning, coordinating, executing and monitoring the progress of the work. The construction work shall be scheduled to be completed within the specified duration of the Contract.

1.02 RELATED WORK SPECIFIED ELSEWHERE

- A. Section 01000 – Special Conditions
- B. Section 00700 – General Conditions
- C. Section 01300 – Submittals

1.03 SCHEDULING RESPONSIBILITIES

- A. The construction schedule will be used to monitor job progress. The Contractor will be responsible for providing all information concerning the sequencing, logic and durations of planned activities. The Contractor will be responsible for providing monthly update information on logic changes, percent complete, actual start and finish dates and duration changes. The Contractor will be required to prepare and submit schedule updates prior to each of the monthly progress meetings.
- B. Assembling the initial schedule in hand drawn or computer-generated (preferred) form is the responsibility of the Contractor.
- C. It should be clearly understood that the initial schedule and all update information must be provided by the Contractor and that this information is a representation of the best efforts of the Contractor and his subcontractors as to how they envision the work to be accomplished. Similarly, all progress information to be provided by and through the Contractor must be an accurate representation of his or his subcontractors' or suppliers' actual performance. The schedule shall at all times remain an accurate reflection of the Contractor's actual or projected sequencing of the work. Once accepted, adherence to the schedule shall be obligatory upon the Contractor and his subcontractor for the work under this Contract. Fayetteville Public Works Commission may require the Contractor to revise the schedule if, in the Project Engineer's judgment, the schedule does not accurately reflect the actual extension of the work, or is in violation of any provision of the Contract Documents. The Contractor shall provide the necessary information required to revise the schedule as often as is necessary during the course of performance of the work without additional cost to the Fayetteville Public Works Commission.

1.04 PROGRESS OF WORK

- A. The work shall be started on the date indicated in the Notice to Proceed and shall be executed with such progress as may be required to prevent delay to other contractors or to the general completion of this project. The Contractor shall at all times, schedule and direct his work so that it provides an orderly progression of the work to completion within the specified Contract Time. The Contractor shall account for traffic control requirements,

lead times for ordering materials, access of citizens within the work area, testing, and the requirements for timely restoration.

- B. The Contractor agrees that, whenever it becomes apparent from the current monthly schedule update that delays to the planned progress of work have resulted and these delays are through no fault of the Fayetteville Public Works Commission and hence, the Contract completion date will not be met, or when so directed by the Project Engineer, he will prepare a recovery schedule outlining steps to recover time and to complete the project on schedule.
 - a. The Contractor shall submit for review a written statement of the steps he intends to take, to remove or arrest the delay to the schedule. The Contractor shall promptly provide such level of effort at no additional cost to the Fayetteville Public Works Commission. In addition, should schedule delays persist, the Contractor's surety will be asked to attend a schedule update meeting.
- C. Failure of the Contractor to comply with the requirements of this section shall subject him to, at the Fayetteville Public Works Commission's sole discretion, withholding, in partial or in total, payments otherwise due the Contractor for work due under this Contract. The Contractor agrees that any withholding of monies is not a penalty for noncompliance, but is an assurance for the Fayetteville Public Works Commission that funds will be available to implement these requirements should the Contractor fail to do so, since failure of the Contractor to comply with these requirements shall mean that the Contractor failed to execute the work with such diligence as to ensure its completion within the time for completion.

2.01 SCHEDULE REQUIREMENTS

- A. The schedule shall show the order and interdependence of activities and the sequence in which the work is to be accomplished as planned by the Contractor. The schedule shall show how the start date of a given activity is dependent on the completion date of preceding activities and how its completion restricts the start of succeeding activities. A time scaled precedence format will be followed. The schedule shall indicate the start date, completion date, and duration (in days), of each activity.
- B. The Schedule Activities shall be developed into two major groups:
 - 1. Construction Activities - Construction activities will be physical work activities that describe how the job will be constructed. Work shall include planned restoration.
 - 2. Post Construction Testing, Start-up, Training and Close-out - Activities for this group shall include all work required satisfying appropriate specification requirements sections and meeting the requirements of final completion. There are at least three (3) mandatory activities: Punch list, Final Walkthrough and Project Completion.
- C. The Contractor shall break the work into activity durations of one (1) to twenty (20) working days each, except for non-construction activities (such as procurement of materials and delivery of equipment) and other activities that may require longer durations. To the extent feasible, activities related to a specific physical or geographic area of the project should be grouped on the schedule for ease of understanding and simplification. The selection and number of activities shall be subject to the review of the Project Engineer.
- D. Each activity on the schedule shall have indicated for it the following:
 - 1. Construction activities will be divided by easily recognizable division points such as stationing or street names, area of work, etc.

2. A brief description of the activity will be included. If this description is not definitive, a separate listing of each activity and a descriptive narrative may be required.
 3. Where the Contractor intends to perform work concurrently, a resource or crew identifier will be assigned to the activity to indicate parallel paths.
 4. Established PWC holidays and other non-work days will be excluded from the schedule.
- E. Failure to include on the schedule any element of work required for the performance of this Contract shall not excuse the Contractor from completing all work required within the applicable Contract Time.
- F. A schedule which shows a completion of any portion of the construction work prior to the Contract Time dates may be accepted but in no event shall be acceptable as a basis for a claim for any delay against the Fayetteville Public Works Commission by the Contractor.

3.01 SCHEDULE IMPLEMENTATION

- A. Within ten (10) calendar days after the pre-construction conference and before commencing any work, the Contractor shall submit three (3) prints of a schedule showing the first 45 calendar days of the work. The Contractor will revise and resubmit the 45 calendar day schedule until it is acceptable.
- B. Prior to submitting the first application for payment, or within (30) calendar days after the Notice to Proceed (whichever comes first), the Contractor shall submit three (3) copies of their proposed construction schedule for the entire Contract duration. Payment shall not be made until the schedule is submitted and approved by the Fayetteville Public Works Commission.
- C. The Contractor may submit the schedule on disk in a format wholly compatible with Microsoft Project. Submission of an electronic schedule does not preclude any other of the aforementioned individual activity requirements.
- D. If a review of the submitted schedule indicates a work plan that will not complete the work within the Contract time, it shall be the responsibility of the Contractor to revise the schedule as required and resubmit it until it is acceptable. Failure by the Contractor to submit an acceptable schedule may, at the Fayetteville Public Works Commission's sole discretion, be cause for the withholding of any partial payment(s) otherwise due under the Contract.
- E. Acceptance of the schedule shall not constitute a representation by the Fayetteville Public Works Commission that the work can be completed as shown on the schedule.

3.02 SCHEDULE UPDATES (MONTHLY PROGRESS MEETINGS)

- A. The Contractor shall submit a Schedule Update on the Monday prior to the monthly progress meeting, (or as directed by the Project Engineer), to allow the Project Engineer to review the schedule. The schedule shall be up-to-date as of the previous Friday or as directed by the Project Engineer.
- B. Actual progress of the previous month shall be recorded and future activities will be reviewed. The duration of activities and their logical connections may be revised as needed. Decisions made at these meetings and agreed to by all parties are binding with the exception that no contractual completion dates will be modified without formal written requests and acceptance as specified in the Contract Documents. The Contractor must provide the following information for each update at a minimum:

1. Actual start and finish dates for all completed activities.
 2. Actual start dates for all started but incomplete activities including remaining durations and/or percent completes.
 3. Revisions in the logic, critical path or resource assigned to an activity that would affect the anticipated early start of all activities not yet started.
 4. Any approved extension of Contract time shall be included in the next monthly updating of the schedule.
- C. Provide a Monthly Progress Status Report that provides the following items:
1. Summarized revisions made to the Construction Schedule since the previous submittal.
 2. Work anticipated to be started during the next period, including those activities already in progress.
 3. Problem areas, anticipated delays, and the impact on the schedule.
 4. Corrective action.
 5. The effect of changes on schedules of other prime Contractors in adjacent work areas.
- D. Failure to provide update information listed above, or failure to attend progress meetings may result in the Owner withholding partial payments.

- END OF SECTION -

**DIVISION 1
01400 QUALITY CONTROL**

QUALITY ASSURANCE

Quality: All materials shall be new and correctly designed, and shall conform to the requirements outlined in these Contract Documents. They shall be standard first-grade quality produced by expert workmen and be intended for the use for which they are offered. Materials which, in the opinion of the Fayetteville Public Works Commission, are inferior or of a lower grade than indicated, specified, or required will not be acceptable.

Source Limitations: To the greatest extent possible for each unit of Work, the Contractor shall provide products, materials, or equipment from a single manufacturer.

Compatibility of Options: If the Contractor cannot obtain all necessary products, materials, and/or equipment from a single manufacturer, the Contractor shall submit compatible products, materials, and/or equipment to the Fayetteville Public Works Commission for review and approval. Once the Fayetteville Public Works Commission has issued approval of the proposed products, materials, and/or equipment, the Contractor shall only utilize that manufacturer's products, materials, and/or equipment, unless otherwise approved in writing by the Fayetteville Public Works Commission.

QUALITY CONTROL

Quality control is the sole responsibility of the Contractor and shall include the activities of his Subcontractors and all suppliers as required.

TESTING SERVICES

The Contractor shall cooperate with the Fayetteville Public Works Commission's Consultant performing required testing and provide equipment, access, or other means required at no additional expense to the Fayetteville Public Works Commission. The Contractor shall be responsible for coordinating testing with the FPWC Project Coordinator. The Contractor shall be responsible for all costs incurred by the Fayetteville Public Works Commission's Consultant when scheduled testing cannot be performed.

The Fayetteville Public Works Commission shall employ and pay for the services of an independent laboratory for specified testing as outlined in these Contract Documents, with the following exceptions:

- If Laws and Regulations of any public body having jurisdiction specifically require any part of the Work to be tested, inspected, or approved by an employee or other representative of that public body, the Contractor shall be responsible for arranging and obtaining such inspections and/or approvals. The Contractor shall bear all costs associated with the required testing, inspections, and/or approvals, and shall furnish the Fayetteville Public Works Commission all required documentation that the required testing, inspection, and/or approvals have been obtained.
- If any part of the Work is found to be defective and not in compliance with the Contract Documents, the Contractor shall be responsible for all subsequent testing necessary to prove that the Work has been brought into compliance. Any necessary testing to ensure

compliance shall be directed by the FPWC Project Coordinator and/or FPWC Project Engineer.

- When scheduled testing by the Fayetteville Public Works Commission's Consultant cannot be performed.
- Arranging and obtaining any required inspections, testing, or approvals required in connection with the Fayetteville Public Works Commission's acceptance of a material supplier, or equipment proposed to be incorporated into the Work, or materials, mix designs, etc. submitted for approval prior to purchase for incorporation into the Work. All inspections, tests, and approvals shall be performed by organizations acceptable to the Fayetteville Public Works Commission.

PRODUCT EVALUATION

Testing shall be accomplished as deemed necessary by the Fayetteville Public Works Commission to ensure that the products conform to the requirements of the Contract Documents.

The work or actions of the testing laboratory shall in no way relieve the Contractor of his obligations under the Contract. The laboratory testing work will include such inspections and testing required by the Contract Documents, existing laws, codes, ordinances, etc. The testing laboratory will have no authority to change the requirements of the Contract Documents, nor perform, accept or approve any of the Contractor's Work.

The Contractor shall allow the Fayetteville Public Works Commission ample time and opportunity for evaluation and testing materials to be used in the Work. The Contractor shall advise the Fayetteville Public Works Commission promptly upon placing orders for materials so that arrangements may be made, if desired, for evaluation before shipment from the place of manufacture. The Contractor shall at all times furnish the Fayetteville Public Works Commission and his representatives, facilities including labor, and allow proper time for evaluation and testing materials, and workmanship. The Contractor must anticipate that possible delays may occur due to the necessity of materials being inspected and accepted for use. The Contractor shall furnish, at his own expense, all samples of materials required by the Fayetteville Public Works Commission for testing, and shall make his own arrangements for providing water, electric power, or fuel for the various evaluation and tests of structures and materials.

The Fayetteville Public Works Commission will bear the cost of all tests, evaluation, or investigations undertaken by the order of the FPWC Project Engineer for the purpose of determining conformance with the Contract Documents if such tests, evaluation, or investigations are not specifically required by the Contract Documents, and if conformance is ascertained thereby. Whenever nonconformance is determined by the Fayetteville Public Works Commission as a result of such tests, evaluation, or investigations, the Contractor shall bear the full cost of any additional tests, evaluations and investigations, which are ordered by the Fayetteville Public Works Commission to ascertain subsequent conformance with the Contract Documents.

EVALUATION AT PLACE OF MANUFACTURE

Unless otherwise specified, all products and materials shall be subject to evaluation by the Fayetteville Public Works Commission at the place of manufacture.

The presence of the Fayetteville Public Works Commission at the place of manufacture however, shall not relieve the Contractor of the responsibility for furnishing products, materials, and equipment which comply with all requirements of the Contract Documents. Compliance is a duty of the Contractor, and said duty shall not be avoided by any act or omission on the part of the Fayetteville Public Works Commission.

SAMPLING AND TESTING

Unless otherwise specified, all sampling and testing shall be in accordance with the methods prescribed in the current standards of the ASTM, as applicable to the class and nature of the article or materials considered. However, the Fayetteville Public Works Commission reserves the right to use any generally accepted system of sampling and testing which will ensure that the quality of the workmanship is in full accord with the Contract Documents.

Any waiver by the Fayetteville Public Works Commission of any specific testing or other quality assurance measures shall not be construed as a waiver of any requirements of the Contract Documents. The Fayetteville Public Works Commission may require a guarantee of substantial performance and/or a performance bond to ensure any necessary corrective or remedial Work, should a waiver be granted.

The Fayetteville Public Works Commission reserves the right to make independent investigations and tests. Failure of any portion of the Work to meet any of the requirements of the Contract Documents shall be reasonable cause for the Fayetteville Public Works Commission to require the removal or correction and reconstruction of any such work in accordance with the Contract Documents. In addition to any other evaluation, observation or quality assurance provisions that may be specified, the Fayetteville Public Works Commission shall have the right to independently select, test, and analyze, at their expense, additional test specimens or any or all of the materials to be used. Results of such tests and analyses shall be considered along with the tests or analyses made by the Contractor to determine compliance with the applicable specifications for the materials so tested or analyzed. The Contractor shall be responsible for all costs of removal, correction, and reconstruction or repair of any such Work that fails to meet the requirements of the Contract Documents.

SITE INVESTIGATION AND CONTROL

The Contractor shall verify all dimensions in the field and shall check field conditions continuously during construction. The Contractor shall be solely responsible for any inaccuracies built into the Work due to their failure to comply with this requirement.

The Contractor shall inspect related and appurtenant Work and shall report in writing to the Fayetteville Public Works Commission any conditions which will prevent proper completion of the Work. Failure to report any such conditions shall constitute acceptance of all site conditions, and any required removal, repair, or replacement caused by unsuitable conditions shall be performed by the Contractor at their sole cost and expense.

RIGHT OF REJECTION

The Fayetteville Public Works Commission shall have the right, at all times, to reject any articles or materials to be furnished hereunder which, in any respect, fail to meet the requirements of the Contract Documents, regardless of whether the defects in such articles or materials are detected at the point of manufacture or after completion of the Work. If the Fayetteville Public Works

Commission, through an oversight or otherwise, has accepted materials or Work which is defective or which is contrary to the Contract Documents, such materials, no matter in what stage or condition of manufacture, delivery, or erection, may be subsequently rejected by the Fayetteville Public Works Commission.

The Contractor shall promptly remove rejected articles or materials from the Work after notification of rejection. All costs of removal and replacement of rejected articles or materials as specified herein shall be borne by the Contractor.

WATERTIGHTNESS OF STRUCTURES

It is the intent of these Contract Documents that all Work shall be performed as required by quality construction to ensure proper sealing so that groundwater and/or rainwater will not leak into any collection line, service lateral, or manhole.

The Contractor shall provide at its own expense all labor, material, temporary bulkheads, pumps, water, measuring devices, etc., necessary to perform the required tests.

HYDRAULIC UPLIFT ON STRUCTURES

The Contractor shall be completely responsible for any pipelines or manholes that may become buoyant before the Work is completed and accepted. The Contractor shall take all necessary steps to prevent any structures from becoming buoyant. Damage to any structures due to floating or flooding shall be repaired or replaced at the Contractor's expense.

TIME OF OBSERVATION AND TESTS

Samples and test specimens required under these Contract Documents shall be furnished and prepared for testing in ample time for the completion of the necessary tests and analyses before said articles or materials are to be used. The Contractor shall furnish and prepare all required test specimens within the scope of the Contract. Except as otherwise provided in the Contract Documents, the performance and cost of the required tests will be the responsibility of the Fayetteville Public Works Commission. However, the costs of any test which shows unsatisfactory results shall be borne by the Contractor. Whenever the Contractor is ready to backfill, bury, cast in concrete, or otherwise cover any Work under the Contract, the Fayetteville Public Works Commission shall be notified not less than twenty-four hours in advance to request inspection before beginning any such Work of covering. Failure of the Contractor to notify the Fayetteville Public Works Commission a minimum of twenty-four hours in advance of any such inspections shall be cause for the Fayetteville Public Works Commission to order a delay in the Contractor's schedule to allow time for inspections. Any remedial or corrective Work required, and all costs of such delays, including its effect upon other portions of the Work, shall be borne by the Contractor.

- END OF SECTION -

**DIVISION 1
01700 PROJECT CLOSEOUT**

FINAL CLEANUP

The Contractor shall promptly remove from the vicinity of the completed Work, all rubbish, unused materials, concrete forms, construction equipment, temporary structures and facilities, construction signs, tools, scaffolding, materials, supplies and equipment which may have been used in the performance of the work. The Contractor shall broom clean paved surfaces and rake clean other surfaces of grounds. Final acceptance of the Work by the Fayetteville Public Works Commission will be withheld until the Contractor has satisfactorily complied with the foregoing requirements for final cleanup of the project site.

The Contractor shall thoroughly clean all materials, equipment and structures; all marred surfaces shall be touched up to match adjacent surfaces.

The Contractor shall remove spatter, grease, stains, fingerprints, dirt, dust, labels, tags, packing materials and other foreign items or substances from interior and exterior surfaces, equipment, signs and lettering.

The Contractor shall remove paint, clean and restore all equipment and material nameplates, labels and other identification markings.

The Contractor shall maintain cleaning until project is accepted by the Fayetteville Public Works Commission.

The Contractor shall:

- A. Use only cleaning materials recommended by manufacturer of surface to be cleaned.
- B. Use each type of cleaning material on only those surfaces recommended by the cleaning material manufacturer.
- C. Use only materials which will not create hazards to health or property.

CLOSEOUT TIMETABLE

The Contractor shall establish dates for testing, acceptance periods, and on-site instructional periods (as required under this Contract). The dates shall be established a minimum of seven (7) calendar days prior to beginning any of the foregoing items, to allow the Fayetteville Public Works Commission sufficient time to schedule attendance at the activities.

FINAL SUBMITTALS

Before the final acceptance of the project, the Contractor shall submit to the Fayetteville Public Works Commission certain records, certifications, etc., which are specified elsewhere in these Contract Documents. Missing, incomplete or unacceptable items, as determined by the Fayetteville Public Works Commission, shall constitute grounds for withholding final payment to the Contractor. A partial list of such items appears below, but it shall be the Contractor's responsibility to submit any other items which are required in these Contract Documents:

- A. Written Test results of project components.
- B. Written guarantees, where required.

- C. Certificates of inspection and acceptance by local governing agencies having jurisdiction.
- D. Releases from all parties who are entitled to claims against the subject project, property, or improvement pursuant to the provisions of law.

PUNCH LISTS

Final cleaning shall be scheduled upon completion of the project.

The Fayetteville Public Works Commission will make his final inspection whenever the Contractor has notified the Fayetteville Public Works Commission that the work is ready for the inspection. Any work not found acceptable and requiring cleaning, repair and/or replacement will be noted on the punch list. Work that has been inspected and accepted by the Fayetteville Public Works Commission shall be maintained by the Contractor, until final acceptance of the entire project.

Whenever the Contractor has completed the items on the punch list, the Contractor shall notify the Fayetteville Public Works Commission that it is ready for final inspection. This procedure will continue until the entire project is accepted by the Fayetteville Public Works Commission. The final payment will not be processed until the entire project has been accepted by the Fayetteville Public Works Commission and all of the requirements in these Contract Documents have been satisfied.

TOUCH-UP AND REPAIR

The Contractor shall repair any and all damage to existing facilities and surfaces. If in the opinion of the Fayetteville Public Works Commission the repair work is not satisfactory, the Contractor shall make repairs until the Fayetteville Public Works Commission accepts it.

MAINTENANCE AND GUARANTEE

The Contractor shall comply with all maintenance and guarantee requirements of these Contract Documents.

Replacement of earth fill, backfill, or asphalt where it has settled below the required finish elevations, shall be considered as a part of such required repair work, and any repair or resurfacing constructed by the Contractor which becomes necessary by reason of such settlement shall likewise be considered as a part of such required repair work unless the Contractor obtained a statement in writing from the affected private owner or public agency releasing the Fayetteville Public Works Commission from further responsibility in connection with such repair or resurfacing.

*** END OF SECTION ***

SECTION D – TECHNICAL SPECIFICATIONS

**DIVISION 2
SITE WORK
02730 - SANITARY SEWER SYSTEMS**

GENERAL

Sanitary sewer lines and all appurtenant items shall be constructed of materials specified or indicated on the drawings. The intent and purpose of these specifications is to require a complete and satisfactory installation in every respect and any defect in material or workmanship shall be cause for the replacement and correction of such defect as directed by the Public Works Commission.

RELATED SECTIONS

- A. 02211 – Grading, Utilities
- B. 02222 – Excavation and Backfilling for Utility Systems
- C. 02732 – Sewage Force Mains

MATERIALS

SEWER MAINS

Prior to shipment each joint of pipe shall be stamped by an independent testing laboratory, certifying compliance with the specifications stated therein. Pipe sizes indicated shall be understood to be nominal inside diameter of the pipe. All sewer pipe materials shall be either PVC (as specified herein) or ductile iron (as specified herein), unless otherwise approved in writing by the Public Works Commission. Written approval shall be obtained prior to installation.

DUCTILE IRON PIPE

The raw material from all ductile iron pipe and fittings shall have an average minimum content consisting of 90% recycled iron and steel. Ductile iron pipe and fittings shall be manufactured in the United States of America in accordance with ANSI/AWWA A21.51/C151. The manufacturer of the ductile iron pipe shall be a member of the Ductile Iron Pipe Research Association (DIPRA).

All ductile iron pipe and fittings shall be in strict accordance with ANSI A21.51 and AWWA C151, Class 50 or Class 51, as applicable, in every respect. The working pressure shall be a minimum of 200 psi. Pipe shall be furnished in 18 or 20-foot lengths. All pipe joints used in open trench construction shall be furnished with "push-on" joints, unless otherwise indicated on the drawings or specified. All joints and fittings shall be in accordance with ANSI A21.11 and AWWA C111. All ductile iron interior surfaces shall be lined with two (2) coats of ceramic epoxy to produce a total minimum dry film thickness of 40 mils (Protecto401 or approved equal). The exterior pipe surfaces shall be protected with asphaltic coating as specified in AWWA C151 and C110. Specifications for the ceramic epoxy can be found in Specification Section 09802.

For aerial crossings which are 4 inches through 12 inches in diameter, manufactured restrained joint ductile iron pipe Class 53, or Class 53 flanged ductile iron pipe shall be utilized in accordance with the standard Public Works Commission detail for aerial crossings. Mega-lugs, field-lok, and gripper rings are not an allowable means of restraint for aerial crossings. For aerial crossings larger than 12 inches, or as noted specifically on the plans, flange joint ductile iron pipe, Class 53, shall be utilized in accordance with the standard Public Works Commission details. The

location of flanges shall be specifically designed for each application. The flange pipe shall be in accordance with ANSI/AWWA C-115/A21.15. Threads for threaded flange pipe shall be in accordance with ANSI B2.1, shop fabricated as outlined by AWWA 115 with serrated faces furnished on the pipe, completely factory installed. Welding of flanges to the body of the pipe will not be acceptable. Ductile iron fittings and flanges shall be in accordance with ANSI/AWWA C-110/A21.10 with a minimum working pressure of 250 psi. Gaskets shall be full faced SBR rubber per ANSI/AWWA C-111/A21.11 with a minimum 1/8" thickness. Linings and coatings shall be as outlined for ductile iron pipe.

If the Public Works Commission determines that an expansion coupling is required, it shall be installed as indicated on the drawings. The expansion coupling shall not be buried.

For subsurface water crossings (i.e., streams, wetlands), restrained joint ductile iron pipe shall be utilized. No mechanical restraint systems (e.g., mega-lugs, field-lok gaskets, etc.) shall be utilized. The pipe shall be installed in a casing, in accordance with the approved Public Works Commission detail, unless otherwise specifically approved by the Public Works Commission.

PVC PIPE

PVC sewer pipe and fittings 4 inches thru 15 inches shall be in accordance with ASTM D-3034 with a standard dimension ratio (SDR) of 26 for sewer mains and laterals. Larger diameter pipe (18 inches through 27 inches) shall be in accordance with ASTM F-679, with a SDR of 26. Both pipe and fittings shall be made of PVC plastic having a cell classification of 12454 as specified in ASTM D-1784.

Pipe joining shall be push on elastomeric gasket joints only and the joints shall be manufactured and assembled in accordance with ASTM D-3212. Elastomeric seals shall meet the requirements of ASTM F-477. The pipe shall be furnished with integral bells and with gaskets that are permanently installed at the factory and in accordance with ASTM D-3212 and contain a steel reinforcing ring. PVC sewer pipe shall be made by continuous extrusion of prime green unplasticized PVC and contain identification markings as required by the applicable ASTM standard.

SEWER FITTINGS

Ductile Iron Push-on Fittings:

Ductile iron sewer fittings on PVC mains shall be deep bell, gasketed joint, and air test rated. Gasket grooves shall be machined in the factory. Material shall be ductile iron, in accordance with ASTM A536, Grade 65-45-12 and ASTM F1336. Wall thickness shall meet the requirements of AWWA C153. Gaskets shall have a minimum cross sectional area of 0.20 square inches, and conform to ASTM F477. All ductile iron fittings shall have an interior coating of Protecto 401, or approved equal. All ductile iron fittings on PVC pipe shall provide a flow line that provides a smooth transition between the materials. Ductile iron fittings shall be as manufactured by the Harrington Corporation (Harco), or approved equal.

Mechanical Joint Fittings:

Joints shall be installed in accordance with AWWA C-600 and shall conform to AWWA Standard C-111. Mechanical joints shall be of the stuffing box type and shall conform to ANSI A21.11 for four inch (4") pipe and larger. Fittings and specials shall be ductile iron and shall be manufactured in accordance with AWWA Standard C-110 (ANSI A21.11). Compact fittings shall be ductile iron in accordance with ANSI A 21.53 (AWWA C-153) for 4" thru 24" sizes only. Note: mechanical joint wyes are not included in the AWWA C-153 specification. Pressure rating shall be not less than 200 psi unless otherwise specified. All ductile iron fittings shall have an interior coating of Protecto 401, or approved equal. Mechanical joint fittings shall be utilized on ductile iron mains and ductile iron laterals. Mechanical joint fittings shall not be utilized on PVC mains, unless otherwise approved by the Public Works Commission.

PVC Fittings:

PVC fittings shall be manufactured in accordance with ASTM D-3034, F-1336, and F-679. Molded fittings shall be utilized in sizes from 4" to 8" (or larger, if available). Fabricated fittings shall only be utilized with prior approval from the Public Works Commission. Fabricated fittings are defined as those fittings that are made from pipe or a combination of pipe and molded components. All PVC fittings shall contain identification markings as required by the applicable ASTM standard. All PVC fittings shall be gasketed joint, except as indicated for interior drop structures. Plastic fittings shall be as manufactured by GPK Products, Inc., Plasti-Trends, the Harrington Corporation (Harco), or approved equal.

Ductile Iron Pipe Size x SDR26 Transition Adapter:

All ductile iron x PVC transition adapters shall be one (1) piece, bell x bell (gasket x gasket). Transition adapters shall range in size from four (4) inches through 12 inches. Transition adapters for pipe larger than 12-inches shall be as specified by the Public Works Commission. All transition adapters shall have a flow way tapered to allow a smooth transition between the ductile iron and PVC. Transition adapters shall be either PVC or ductile iron, in accordance with the following:

PVC – All PVC transition fittings shall be made from DR 18 C900 pipe stock. The C900 pipe stock shall meet the requirements of AWWA C900/C905, and have a minimum cell classification of 12454 as defined in ASTM D1784. The wall thickness shall meet or exceed DR 18. PVC transition fittings shall have SBR gaskets in accordance with ASTM F477. All six (6) inch and eight (8) inch adapters shall be molded. Molded fitting joints shall be 235 psi rated, in accordance with ASTM D3139, and shall have SBR rubber gaskets. Four (4) inch, ten (10) inch and 12 inch transition adapters shall have SBR Rieber style gaskets meeting ASTM F477. Joints shall be 235 psi rated, in accordance with ASTM D3139 for the C900 (ductile iron) bell, and in accordance with ASTM D3212 for the sewer (SRD26) bell. Molded C900 bell depths shall comply with AWWA C907. Fabricated (4-inch, 10-inch and 12-inch) bell depths and molded sewer (SDR26) bell depths shall be in accordance with ASTM F1336. PVC transition adapters shall be manufactured by the Harrington Corporation (Harco), GPK Products, or approved equal.

Ductile iron – Ductile iron transition fittings shall be deep bell, push-on joint, and air test rated. The ductile iron material shall comply with ASTM A536, Grade 65-45-12 or 80-55-06. The bell depth shall be in accordance with ASTM F1336. Gaskets shall be of SBR rubber, in accordance with ASTM F477. Transition gaskets are not allowed. All ductile iron transition fittings shall have an interior coating of Protecto401 or approved equal. Ductile iron transition fittings shall be manufactured by the Harrington Corporation (Harco) or approved equal.

Saddles:

Sewer service saddles may be utilized for sewer lateral installations. All sewer service saddles shall be ductile iron with stainless steel straps, bolts, nuts, and washers. The nuts shall be coated to prevent galling. The saddle body shall be ductile iron, in accordance with ASTM A536, Grade 65-45-12. The gasket material shall be SBR, in accordance with ASTM D2000. Saddles for PVC or DI laterals shall have an alignment flange. Sewer service saddles shall be as manufactured by Geneco, or approved equal. All stainless steel straps shall be pre-formed at the factory, to the specified outside diameters of the pipe.

SEWER LATERALS

Ductile iron laterals – For ductile iron mains, utilize mechanical joint fittings or an approved saddle with an alignment flange (Geneco or approved equal). For PVC mains, utilize an approved saddle with an alignment flange (Geneco or approved equal) or ductile iron fittings as specified above.

PVC laterals – utilize a saddle with an alignment flange (Geneco or approved equal) on PVC or ductile iron mains; utilize a mechanical joint tee with SDR 35 transition gaskets on ductile iron mains; or utilize PVC fittings as specified above on PVC mains.

The following table summarizes the materials to be utilized for sewer main to lateral connections:

	PVC Main	DI Main
DI Lateral	DI fitting or approved saddle	MJ fitting or approved saddle
PVC Lateral	PVC fitting or approved saddle	MJ fitting with transition gasket or approved saddle

Sewer laterals shall be in accordance with these Specifications and PWC standard details S.10, S.11, and S.12.

PRECAST CONCRETE MANHOLES

Pre-cast circular reinforced concrete manhole units shall be in accordance with ASTM C-478. The tongue and groove ends of the manhole sections shall be manufactured for jointing with rubber gaskets (i.e., con-seal). An eccentric cone shall be utilized on all manholes, unless otherwise approved by the Public Works Commission.

Manhole steps shall be placed in all manholes and shall be steel reinforced (½" grade 60) copolymer polypropylene plastic steps in accordance with ASTM C-478 for material and design. The steps shall be spaced 16" on center with serrated treads and wide enough to stand on with both feet.

Manhole frames and covers shall be made of gray cast-iron, and the iron shall possess a tensile strength of not less than 18,000 psi. Cast iron shall conform to ASTM Specification A 48-83 Class 35. The frame and cover shall be manufactured by the same manufacturer. All castings shall be in accordance with Public Works Commission standard details. Any defective castings shall be removed and replaced.

Any special linings and coatings that are specified for a manhole and installed at the production facility, in the field, or during repairs, shall be applied in accordance with the applicable special coatings specification and the manufacturer's specifications for that material.

Camlock ring and covers shall be in accordance with Public Works Commission standard details. Camlock bolt head shall be compatible with PWC standard tool for turning camlock mechanism. Camlock ring and covers shall be installed as indicated on the drawings, in accordance with PWC standard details.

SELECT BEDDING MATERIAL

Select bedding material shall be crushed stone (No. 57 or No. 5), in accordance with Public Works Commission standard details. Bedding material shall be provided for all pipe materials.

INSTALLATION

Pipe installation shall be in strict accordance with Specification Section 02222 – Excavation and Backfilling for Utility Systems and as outlined herein.

PIPE LAYING

Pipe installation shall be in accordance with the manufacturer's instructions. Proper equipment shall be utilized to perform the work in a manner satisfactory to PWC. All pipes and fittings shall be carefully lowered into the trench in such a manner to prevent damage to the protective coatings and linings. Under no circumstances shall pipe materials be dropped or dumped into the trench. Pipe shall be carried into position and not dragged.

All dust, dirt, oil, tar (other than standard coating), or other foreign matter shall be cleaned from the jointing surfaces, and the gasket, bell, and spigot shall be lubricated with lubricant recommended by the manufacturer.

The pipe shall be laid upgrade, beginning at the lower end with the tongue or spigot ends pointing in the direction of the flow to the correct line and grade, unless otherwise approved by PWC. The pipe section to be installed shall be aligned by batter board or laser beam with the last installed pipe section. Mechanical equipment should not be used to assemble the pipe. Pipe shall be assembled in accordance with the pipe manufacturer's instructions. Any damage resulting from the use of mechanical equipment shall be replaced as directed by PWC.

Adjustments in grade by exerting force on the barrel of the pipe with excavating equipment shall not be allowed. The Contractor shall verify line and grade after assembling each joint.

At any time when pipe laying is not in progress, the open ends of the pipe shall be closed by a water tight plug or other means approved by the PWC Project Coordinator. If water is in the trench, the plug shall remain in place until the trench is pumped completely dry. No pipe shall be laid in water or where in the PWC Project Engineer's and/or PWC Project Coordinator's opinion trench conditions are unsuitable. Every precaution shall be taken to prevent material from entering the pipe while it is being installed.

ALIGNMENT AND GRADE

All pipe shall be installed to the required lines and grades. Structures shall be installed at the required locations. The lines and grades of the pipe will generally be indicated by stakes parallel to the line of the pipe. The Contractor shall be responsible for installing the pipe to proper line and grade.

Pipe shall be visually inspected by shining a light between structures and /or by closed circuit television inspection. Any defects discovered, including poor alignment, shall be corrected as directed by the Public Works Commission.

The bottom of the trench shall be excavated to a minimum of four inches (4") below the outside bottom of the pipe being installed to allow adequate placement and compaction of bedding material prior to installation.

Select bedding material shall be placed a minimum of four inches (4") and a maximum of six inches (6") under the pipe for full width of the trench and halfway up the pipe on the sides. Bedding material shall be placed in layers not exceeding six inches (6") loose thickness for compacting by vibratory mechanical tamps under the haunches and concurrently on each side of the pipe for the full width of the trench. The final result shall be "Class B" bedding for rigid pipe. If the existing material under the pipe bedding material is unsuitable, the unsuitable material shall be removed and replaced with select bedding material (No. 57 or No. 5 stone), as authorized and approved by the Public Works Commission Project Coordinator.

The same material pipe shall be utilized from manhole to manhole, unless otherwise approved by PWC. If the section of pipe between manholes is 250 feet or less, no transitions will be allowed (either all PVC or all ductile iron). Should the length between manholes exceed 250 feet, only one transition will be allowed. Use of a C900 x SDR 26 adaptor shall be used to accomplish the transition. A transition is defined as the use of one C900 x SDR26 adaptor. No more than one (1) adaptor shall be utilized in any given manhole to manhole segment.

All manholes shall be constructed to Public Works Commission's standards. Installation shall be in accordance with ASTM C-891 and PWC standards.

Manholes shall be constructed of precast reinforced concrete circular sections installed on a base riser section with integral floor and shall be cored to accommodate the various pipe connections, as indicated on the drawings. Pipe connections to a manhole shall be by gasketed flexible watertight connections (boot for small diameter and A Loc for larger diameter pipe) or as approved by the Public Works Commission. The manhole size shall be in accordance with the following table, unless otherwise specified:

<u>Pipe Size</u>	<u>Manhole Diameter</u> **
24" and less	48" *
27" - 36"	60"
42"	72"

* Where interior drop structures are required, use 60" diameter as required in the Public Works Commission standard details.

** Where multiple connections or acute angles are required, larger diameter manhole may be required as indicated on the plans.

The invert channel shall be constructed of brick and mortar, in accordance with Public Works Commission standard details. **Precast inverts are not allowed.** The invert channel shall be smooth and semicircular in shape conforming to the inside of the connecting sewer section. Changes in direction of flow shall be made with a smooth curve as large as a radius as the size of the manhole will permit without a decrease in flow velocity. Changes in size and grade of the channel shall be made gradually and evenly. The invert channel walls shall be constructed to three quarters (3/4) of the height of the crown of the outlet sewer and in such a manner not to obstruct maintenance, inspection or flow in the sewers. The inverts shall have a minimum slope of one (1) percent across the bottom of the manhole. A shelf shall be provided on each side of any manhole invert channel. Inverts in manholes with standing water will not be acceptable. The shelf shall be sloped not less than 1:12 (min) and no more than 2:12 (max). The bottom of the boot for the new sewer main or lateral shall be set one inch above existing shelf unless otherwise indicated.

When used in a paved street, the ring and cover shall be set in suitable mortar surrounded by a concrete collar in accordance with Public Works Commission standard details. When used in places other than in a paved street, the ring and cover shall be set to the grade shown on the plans or directed by the Public Works Commission. In unpaved areas cam-lock ring and cover shall be used. Camlock ring and cover shall be installed in accordance with Public Works Commission standard details.

The interior manhole riser joints, lift holes and grade adjustment rings shall be sealed with non-shrinking mortar to provide a watertight manhole. Lift holes sealed by the manufacturer with plastic caps do not require mortar seal. The hardened mortar shall be smooth to rub with no sharp edges. Use of grade rings with cam-lock ring and cover are not allowed, unless approved by the PWC Project Coordinator. **Use of grade rings is not allowed for above grade adjustments.**

All exterior manhole riser joints, including the joint at the cone, shall be sealed with an external rubber sleeve. The sleeve shall be made of stretchable, self-shrinking rubber, with a minimum thickness of 30 mils. The back side of each wrap shall be coated with a cross-linked reinforced butyl adhesive. The butyl adhesive shall be a non-hardening sealant, with a minimum thickness of 30 mils. The seal shall be designed to stretch around the manhole joint and then overlap to create a fused bond between the rubber and butyl adhesive. The application shall form a continuous rubber seal for the life of the application. The sealing system shall be as manufactured by Concrete Sealants, Inc. (Con-Seal), Sealing Systems, Inc., or approved equal. The wrap shall be a minimum of six (6) inches in width, and shall be centered on the joint. All manhole joints (including the cone section to the last riser) shall be wrapped and sealed. Care shall be taken to prevent damage to the wrap during backfill operations. The manhole surface shall be prepared in accordance with manufacturer's specifications, prior to installing the joint wrap.

Materials shall not enter the sewer line during construction of the manhole. The manhole shall be kept clean of any and all debris or materials. Any debris or material that entered the manhole shall be immediately removed. This condition shall be maintained until final acceptance of the work.

CONNECTION TO EXISTING MANHOLES OR LIFT STATIONS

All connections to existing manholes and/or lift stations shall be approved by the Public Works Commission. Where new mains are to be connected to existing active sanitary sewers, the active

sewers shall remain in service. Unless otherwise indicated, where new lines are connected into existing manholes, all or such portion of the manhole invert as is necessary shall be removed and a new invert shall be constructed to accommodate both new and existing flows. All work shall conform to the requirements specified for new manholes. The existing structure connection shall be cored and a flexible watertight connection (i.e., boot) installed. The boot shall be installed in accordance with Public Works Commission standard details and requirements. The Contractor shall coordinate and cooperate with the Public Works Commission's Project Coordinator.

PIPE TO MANHOLE CONNECTOR (BOOT)

A watertight, flexible pipe-to-manhole connector shall be utilized on all pipe to manhole connections, for both new and existing manholes and pipes, unless otherwise specifically authorized in writing by the Public Works Commission.

The connector assembly shall be the sole element to provide a watertight seal of the pipe to the manhole or other structure. The connector shall consist of a rubber gasket, an internal compression sleeve, and one or more external take-up clamps. The connector shall consist of natural or synthetic rubber and Series 300 non-magnetic stainless steel. No plastic components shall be allowed.

The rubber gasket shall be constructed of synthetic or natural rubber, and shall meet or exceed the requirements of ASTM C-923. The connector shall have a minimum tensile strength of 1,600 psi. The minimum cross-sectional thickness shall be 0.275 inches.

The internal expansion sleeve shall be comprised of Series 300 non-magnetic stainless steel. No welds shall be utilized in its construction.

Installation of the connector shall be performed utilizing a calibrated installation tool furnished by the connector manufacturer. Installation shall require no re-tightening after the initial installation. Installation shall be done in accordance with the manufacturer's instructions.

The external compression take-up clamps shall be Series 300 non-magnetic stainless steel. No welds shall be utilized in its construction. The clamps shall be installed utilizing a torque-setting wrench furnished by the connector manufacturer. Installation shall be done in accordance with the manufacturer's instructions.

The Contractor shall utilize the proper size connector in accordance with the connector manufacturer's recommendations. All dead-end pipe stubs shall be restrained in accordance with ASTM C-923.

The finished connection shall provide a sealing to a minimum of 13 psi, and shall accommodate a minimum pipe deflection of seven (7) degrees without the loss of seal.

The pipe to manhole connector shall be PSX: Direct Drive as manufactured by Press-Seal, or approved equal.

INSIDE DROP MANHOLE STRUCTURE

Inside manhole drop structures shall be constructed and installed in accordance with Public Works Commission standard details.

CLEANING

Prior to final inspection, all sanitary sewer laterals, mains, and manholes newly installed on the collection system shall be flushed and cleaned. During the flushing operation, the downstream manhole shall be closed with a watertight plug to protect the existing sewer main. All water and debris shall be removed and properly disposed of by the Contractor. This condition shall be maintained until the Public Works Commission issues final acceptance for the project.

TESTING

Completed sewers shall be tested in accordance with the provisions outlined below. The Contractor shall furnish all equipment, labor, materials, and pay all costs associated with the tests performed. The Contractor shall schedule all testing with the Public Works Commission's Project Coordinator, a minimum of 48 hours in advance. The Contractor shall cooperate with the Public Works Commission's Project Coordinator and furnish any needed assistance necessary to complete the required testing.

For annexation and/or retrofit projects: No testing shall be conducted prior to successful completion of the compaction testing.

For all other projects: No testing shall be completed until all utilities are installed, prior to preparation of the road subgrade. The Contractor may elect to perform testing to satisfy them that the sewer utility is installed properly prior to commencing installation of other utilities. However, such testing shall not be construed as acceptance by PWC.

The deflection/mandrel test shall not be performed until a minimum of thirty (30) calendar days after backfill operations are completed and the area graded to final contours. In lieu of waiting thirty (30) calendar days, the Contractor has the option to have an independent testing laboratory verify that compaction has been completed to achieve the maximum density as shown in the detail. The location and elevation of the compaction testing shall be determined reviewed and approved by the Public Works Commission's Project Coordinator. The Contractor shall provide the Public Works Commission with a copy of the density testing results.

Compaction testing shall be done in accordance with Specification Section 02222 – Excavation and Backfilling for Utility Systems.

Vacuum Testing Manholes:

All precast sanitary sewer manholes installed by the Contractor shall be vacuum tested for leakage. This test shall be done in accordance with ASTM C-1244 and in the presence of a Public Works Commission Project Coordinator. The Contractor shall be responsible for providing all the necessary labor, materials, equipment, testing apparatus, and all other incidentals necessary to complete the vacuum test. All testing equipment utilized shall be approved for use in vacuum testing manholes.

Each manhole shall be tested after assembly. All lift holes shall be plugged with an approved non-shrink grout. All lines, including laterals, entering the manhole shall be temporarily plugged. The Contractor should take care to ensure that the pipes and plugs are secure in place to prevent them being drawn into the manhole. The test head shall be placed directly on top of the concrete surface of the manhole following the manufacturer's recommendations, rather than to the cast iron seating ring.

Manholes may be tested either prior to backfill or post backfill at the contractor's option. For pre-backfill testing, a vacuum of 10 inches of Mercury (inches Hg) shall be drawn on the manhole, the valve on the vacuum line of the test head closed, and the vacuum pump shut off. The time shall be measured for the vacuum to drop to 9 inches of Mercury (inches Hg). The manhole is acceptable if the time for the vacuum reading to drop from 10 inches of Mercury to 9 inches of Mercury meets or exceeds the values indicated below:

<u>Manhole Depth</u>	Diameter of Manhole		
	<u>4' Diameter</u>	<u>5' Diameter</u>	<u>6' Diameter</u>
10' or less	25 sec	33 sec	41 sec
11' to 15'	38 sec	49 sec	62 sec
16' to 20'	50 sec	65 sec	81 sec
21' to 25'	62 sec	82 sec	101 sec
25' to 30'	74 sec	98 sec	121 sec

Vacuum testing backfilled manholes is not recommended in the presence of groundwater. Vacuum testing a backfilled manhole that is subjected to hydrostatic pressure may exceed the design limits of the flexible connectors and could lead to failure of the structure, joints, and/or connectors. Where groundwater is present a reduction in the vacuum pressure applied to the manhole will be required. The vacuum shall be reduced by 1 inch of Mercury for every 1 foot of hydrostatic head between 12 feet and 21 feet. A vacuum test should not be performed when the hydrostatic head exceeds 22 feet. See the chart below:

Hydrostatic Head (ft)*	12	13	14	15	16	17	18	19	20	21	22
Vacuum Pressure (in Hg)	10	9	8	7	6	5	4	3	2	1	**

*Hydrostatic head above the critical connector (critical connector is bottom most flexible connector)

**Do not perform vacuum test

If the manhole fails the initial test, the manhole shall be repaired by an approved method until a satisfactory test is obtained. All repair methods shall be approved by the Public Works Commission prior to being utilized. Retesting shall be performed until a satisfactory test is accomplished.

Mandrel Testing:

Deflection tests shall be performed on all PVC pipe installations. PVC pipe's maximum deflection after backfilling shall not exceed five (5) percent. The rigid ball or mandrel used for the deflection test shall have a diameter not less than 95 percent of the base inside diameter or average inside diameter of the pipe depending on the type of pipe manufactured and the applicable ASTM Standard. The PVC pipe shall be measured in compliance with ASTM D2122 "Standard Test Method of Determining Dimensions of Thermoplastic Pipe and Fittings". The Contractor shall supply all labor, equipment and materials necessary to perform the test in the presence of the Public Works Commission's Project Coordinator. The test shall be performed without mechanical pulling devices. The mandrel shall be constructed so as to preclude any yield in diameter, and

with a pull line on each end to facilitate withdrawal. If the deflection exceeds the allowable, the Contractor shall remove and replace the pipe.

Air Testing:

Air testing shall be performed on all mains and laterals to determine acceptability. The length of sewer subject to an air test shall be the distance between two adjacent manholes. The tests shall be conducted in accordance with the appropriate ASTM standard. The air test shall be coordinated with the Public Works Commission. The Contractor is required to supply all equipment, labor, materials and pay all costs associated with the test performed.

Air Test for PVC Pipe

The low pressure air test on PVC pipe shall be performed with satisfactory results in accordance with ASTM F1417 "Standard Test Method for Installation Acceptance of Plastic Gravity Sewer Lines Using Low-Pressure Air". The pipe, including lateral assemblies, shall be plugged and air added slowly until the internal pressure of the line is raised to 4.0 psi. After the pressure of 4.0 psi is obtained, regulate the air-supply so that the pressure is maintained between 3.5 and 4.0 psi for at least two (2) minutes, depending on air/ground temperature conditions. The pressure will drop slightly until equilibrium is obtained; however, a minimum of 3.5 psi is required. Once the 3.5 psi is maintained, the test will begin. If the pressure drops 1.0 psi within the time indicated below, the test fails.

Pipe Dia (in)	Minimum time (minutes)	Length for Min Time (ft)	Time for Longer Length (sec)
4	3:46	597	0.380L
6	5:40	398	0.854L
8	7:34	298	1.520L
10	9:26	239	2.374L
12	11:20	199	3.418L
15	14:10	159	5.342L
18	17:00	133	7.692L
21	19:50	114	10.470L
24	22:40	99	13.674L
27	25:30	88	17.306L
30	28:20	80	21.366L
33	31:10	72	25.852L
36	34:00	66	30.768L

The Contractor shall observe all safety precautions to include allowing no one in the manholes during testing, securing all plugs and providing additional plug bracing. The Contractor shall be required to furnish, install and remove after testing at no additional cost, a temporary glue cap/plug to be airtight for all cleanout stacks to accomplish air testing. The air pressure shall never exceed 8 psi. All gauges shall be accessible outside of the manholes.

HYDROSTATIC TESTS

After the ductile iron sewer pipe has been laid within the "protected" area and backfilled to finished grade, the pipe shall be subjected to a hydrostatic pressure test. All laterals within the "protected" area shall be ductile iron. All sewers subject to hydrostatic testing shall include (1) sewers

entering or crossing streams, (2) sewers located less than 100 feet from any public or private water supply source including any WS-I waters or Class I or Class II impounded reservoirs, (3) where the minimum 18 inch vertical and 10 feet horizontal separation cannot be maintained between sewers and water mains (see NC DENR Regulations), or (4) as specified and/or indicated on the drawings. The Contractor will furnish all labor and material, including test pumps, plugs, and all other incidentals for making hydrostatic tests. Hydrostatic pressure testing shall be conducted on the completed main, including the laterals.

The duration of the pressure test shall be at least one hour or longer, as directed by the Public Works Commission. The hydrostatic pressure shall be 150 psi. Each section of pipe shall be slowly filled with water and the specified test pressure based on the elevation of the lowest point of the line or section under test and corrected to the elevation of the test gauge, shall be applied by means of a pump connected to the pipe in a manner satisfactory to the Public Works Commission. Before applying the specified test pressure, all air shall be expelled from the pipe.

All joints showing visible leaks shall be made tight. Cracked or defective pipe, joints, laterals, and fittings discovered in consequence of the pressure test shall be removed and replaced with sound material, and the test shall be repeated until the test results are satisfactory. The requirement for the joints to remain exposed for the hydrostatic test may be waived by the Public Works Commission in certain situations. The test shall be repeated until satisfactory to the Public Works Commission.

The results of the pressure tests shall be satisfactory as specified. All replacement, repair, or retesting shall be accomplished by the Contractor. All repairs shall be reviewed and approved by the Public Works Commission prior to backfill. The use of couplings, sleeves, etc. shall be reviewed and approved by the Public Works Commission prior to use.

END OF SECTION

**DIVISION 2
SITE WORK
02750 - WASTEWATER FLOW CONTROL**

GENERAL

The intent and purpose of these specifications is to provide wastewater flow control, i.e., bypass pumping, of the sanitary sewer flows during the Contractor's operations. The Contractor shall furnish all labor, materials, accessories, equipment and tools for performing all operations required to bypass pump sewage around a manhole or sewer section in which work is to be performed.

The Contractor shall provide all pumps, piping, and other equipment to accomplish this task; perform all construction; obtain all permits; pay all costs; and perform complete restoration of all existing facilities to equal or better condition to the satisfaction of Fayetteville Public Works Commission. The Contractor shall be responsible for the design, installation, operation, and maintenance of the temporary bypass pumping system. The Contractor shall provide sufficient documentation to Fayetteville Public Works Commission to demonstrate that he, or his designated subcontractor, have the experience in the design, installation, and maintenance of temporary bypass pumping systems.

RELATED SECTIONS

- A. Section 02305 – Pipe Bursting
- B. Section 02500 – Traffic Control
- C. Section 02730 – Sanitary Sewer System
- D. Section 02760 – Television Inspection
- E. Section 02766 – Sewer Line Cleaning
- F. Section 02780 – Cured-in-Place Lining

REQUIREMENTS

The Contractor shall be responsible for all aspects of the bypass operation, including but not limited to: providing access to install, move, and maintain the pumps in the proper position, traffic control, installation and removal of bypass equipment, pump monitoring, testing of the bypass system, re-fueling, maintenance, notification of property owners (should access to private property be necessary), wastewater and fuel spill containment, and removal and replacement of manhole cones (if necessary). The bypass system (pumps and piping) shall be monitored by Contractor personnel at all times, when the bypass operation is in effect.

The Contractor shall have all materials and equipment on site to immediately respond to any emergencies or other event that could impact the bypass system (i.e., leak in the discharge piping, pump failure, flooding, etc.). The Contractor shall have sufficient support staff and equipment to mobilize to repair and/or service any equipment within one (1) hour of notification, 24 hours a day, seven (7) days a week. In the event of an emergency, the Contractor shall provide an immediate response and fully cooperate with Fayetteville Public Works Commission.

The Contractor shall install the bypass pumps, equipment, and discharge lines to minimize impacts to the property owners, residents, and environment. The Contractor shall be responsible for determining the best location for the bypass equipment, to include, but not limited to, the need for any special provisions to ensure access for the customers, preventing the pumps and

manholes from flooding, etc. Such special provisions include, but are not limited to: installation of ramps, excavation and burial of the bypass lines, temporary fencing, sandbagging, construction of berms, raising the pumps, etc. The Contractor bears all responsibility for the maintenance and restoration of any trenches, ramps, access, etc. necessary for the temporary bypass pumping operation.

The Contractor shall take appropriate steps to ensure that all pumps, piping and hoses that carry raw sewage are protected from traffic. The Contractor shall identify the proposed methods to protect the temporary bypass pumping system from traffic as part of the detailed temporary bypass pumping plan. Traffic control shall be performed in accordance with these Contract Documents.

The bypass pumping system shall be monitored by Contractor personnel at all times (24 hours a day, 7 days a week), when the bypass operation is in effect. The Contractor's personnel shall be on-site at all times (24 hours a day, 7 days a week), and stationed at the primary bypass pumps. Depending on the location and system set-up, it may be necessary for the Contractor to station personnel at each of the various bypass pump locations. Unless otherwise approved by Fayetteville Public Works Commission, one (1) person cannot monitor multiple bypass pump locations. All bypass pumps, regardless of their location (primary or on secondary lines), shall be equipped with an automatic dialer (or other similar device). The Contractor personnel shall immediately respond to any issue regarding the temporary bypass pumping system. All temporary bypass piping shall be periodically monitored (patrolled from pumps to discharge), but no less frequently than once every 12 hours. The bypass pumping equipment shall be automated and capable of functioning without the assistance of an operator.

SUBMITTALS

All submittals shall be provided in accordance with these Contract Documents, and the requirements outlined herein. The Contractor shall submit a detailed bypass pumping plan to Fayetteville Public Works Commission for approval, prior to initiating the bypass operation. The Contractor shall submit this information far enough in advance to allow sufficient time to complete the necessary coordination, including but not limited to obtaining permits (i.e., encroachments), getting permission from property owners to cross and/or utilize their property, and gaining any necessary regulatory approvals. Failure to submit a complete and comprehensive bypass pumping plan in a timely manner shall not be cause for any extension of the Contract Time.

The detailed temporary bypass pumping plan shall include the following information:

- Method of monitoring the pumps to ensure proper operation, to include method of notifying personnel (Fayetteville Public Works Commission and Contractor) in the event of an emergency, activation of back-up pumps, etc.
- Method of monitoring upstream system levels to ensure surcharging does not result in back-ups into buildings, overflows, etc.
- The amount, if any, of any required surcharging.
- Method to initiate back-up pumps.
- Map showing general location of the pumps and bypass lines. This shall include means to maintain access to driveways, etc.
- Measures to secure the bypass system (lines, pumps, etc.) from traffic, vandalism, high stream flows, etc.
- Method of plugging (and securing the plug(s)) and type of plugs.

- Size and location of manholes or other access points for suction and discharge piping.
- Size of pipeline(s) or conveyance system(s) to be bypassed.
- Number, size, material, location, and method of installation of suction piping.
- Number, size, material, location, and method of installation of discharge piping.
- Bypass pump sizes, capacities, and number of each size to be provided on-site, including all primary, secondary, and spare pumping units.
- Calculations of static lift, friction losses, minimum inlet submergence, and flow velocity (pump curves showing pump operating range shall be submitted). Calculations shall be signed and sealed by a licensed Professional Engineer registered in the State of North Carolina. Calculations shall be provided for both the peak flow rate and a normal daily rate (see PUMPING AND BYPASSING section for sizing requirements).
- Measures to protect discharge manhole(s) or structure(s) from erosion and damage due to the bypass operation.
- Erosion control measures.
- Emergency contact information for the personnel responsible for the pump operation.
- Emergency contact information for Contractor personnel to respond in the event of an emergency.
- List of available resources (equipment, materials, personnel) and contact information for emergency response.
- Method to contain potential releases of sewer flow from air release valves.
- Contingency plan for responding to potential sewer spills caused by weather, vandalism, acts of God, etc. The plan shall include communication protocols, available resources, and the steps to be taken in the event of an emergency.

No bypass operations shall proceed until all bypass submittals have been reviewed and approved by Fayetteville Public Works Commission.

COORDINATION

The Contractor shall fully coordinate their temporary bypass pumping operations with Fayetteville Public Works Commission. It is the Contractor's responsibility to fully determine the scope and location of the temporary bypass pumping system. As outlined in these Contract Documents, Fayetteville Public Works Commission may provide assistance with the building and maintenance of access roads, clearing of easements, etc. All coordination (to include location of the pumps and discharge lines) shall be fully discussed and agreed to prior to commencement of bypass operations.

The Contractor shall schedule a coordination meeting with Fayetteville Public Works Commission and other personnel (Contractor, bypass sub-contractor, etc.) a minimum of three (3) business days prior to starting the temporary bypass pumping system. The purpose of this coordination meeting is to ensure that the Contractor and their sub-contractors have a good understanding of the requirements and expectations of operating the temporary bypass pumping system, discuss contingency plans (to include protocols for emergency contacts), identify location(s) of pumps, verify necessary materials (repair sleeves, containment devices, etc.) are on-site and available, and any other items necessary to ensure that Fayetteville Public Works Commission has confidence that the appropriate personnel can operate and maintain the temporary bypass pumping system. Should, for any reason, Fayetteville Public Works Commission deem that the Contractor and/or their sub-contractor is not prepared to operate and maintain the temporary bypass pumping system, the temporary bypass pumping system shall not be started. The Contractor shall take all necessary steps to address any concerns to the satisfaction of

Fayetteville Public Works Commission. Upon completion of those actions, another coordination meeting shall be held, in order for Fayetteville Public Works Commission to confirm that the Contractor and their sub-contractor is prepared to operate and maintain the temporary bypass pumping system. This process will be repeated until Fayetteville Public Works Commission is satisfied that the Contractor and their sub-contractor are prepared to operate and maintain the temporary bypass pumping system. No additional contract time will be granted for this delay.

The temporary bypass pumping system shall run for a minimum of 24 hours, or longer as deemed by Fayetteville Public Works Commission, prior to any activity occurring (cleaning, closed circuit television {CCTV}, etc.) within the main(s) being bypassed.

FLOW CONTROL PRECAUTIONS

Where the raw sewage flow will be blocked during the Work as a result of the temporary bypass pumping operation, the Contractor shall take all necessary precautions to protect the public health. No septic conditions shall be allowed due to Contractor's operations. The sewer system (mains, manholes, laterals, etc.) shall also be protected from damage. The following occurrences shall not be allowed:

1. No sewage shall be allowed to back up into any homes or buildings.
2. No sewage shall overflow any manholes, cleanouts or any other access to the sewers.
3. Users upstream of the project area shall be able to use all their water and sewer utilities without interruption or limitations.

If any of the above occur or are expected to occur, the Contractor shall take immediate action to alleviate one or all of the conditions. Additionally, the Contractor is required to observe the conditions upstream of the plug and be prepared to immediately increase bypass pumping or release the flows, as required. Any damage claims resulting from the Contractor's failure to properly maintain sewer flows shall be the Contractor's responsibility.

All sump pumps, bypass pumps, trash pumps or any other type pump which pulls sewage or any type of material out of the sanitary sewer system shall discharge into another sanitary sewer manhole, or appropriate vehicle or container acceptable to Fayetteville Public Works Commission. Under no circumstances shall untreated sanitary sewer be discharged, stored or deposited on the ground, swale, road or open environment. The Contractor shall not allow any flow of sewage onto private property, streets, or into creeks and drainage systems. Damage due to negligence of the Contractor, including, but not limited to, flooded dwellings, damaged property, damaged driveways, etc., shall be corrected immediately by the Contractor at no additional cost to Fayetteville Public Works Commission.

PLUGGING AND BLOCKING

In some applications, the wastewater flow may be plugged and contained within the capacity of the collection system. This shall only be done when it has been determined the system can accommodate the surcharging without any adverse impact. The Contractor has the sole responsibility for determining whether the system can accommodate surcharging. If this option is selected, the Contractor shall be responsible for continuously monitoring the system to ensure no sewer spills or overflows occur.

A sewer line plug shall be inserted into the line at a manhole upstream from the section being surveyed or repaired. The plug shall be so designed that all or any portion of the operation flows

can be released. The Contractor shall secure the plug, to prevent it from being dislodged and moving downstream. Flows shall be bypassed for the initial CCTV inspection and shall be bypassed throughout the duration of the work, to include the final CCTV inspection. Flows shall be bypassed in accordance with the approved temporary bypass pumping plan. Upon acceptance of the work by Fayetteville Public Works Commission, the temporary bypass pumping system shall be removed and flows restored.

PUMPING AND BYPASSING

The Contractor, when and where required, shall divert sewer flows for the sewer pipe rehabilitation process, cleaning, television inspection, pipe repairs, manhole replacement and/or rehabilitation, obstruction removals, or other related as required to complete the Work. The pumps and bypass lines shall be of adequate capacity and size to handle and prevent backup or overflow for all flows.

The temporary bypass pumping system shall be designed to maintain the flows necessary to meet the requirements of each particular location. The temporary sewer bypass system shall have the capacity to handle the flows outlined in these Contract Documents. The temporary sewer bypass system shall be sized to handle 2.5 times the average daily flow rate, or the specified peak flow – whichever is greater.

The Contractor shall be responsible for furnishing the necessary labor and supervision to set up, operate, and maintain the temporary bypass pumping system. A “set up” consists of the necessary pumps, conduits and other equipment to divert the flow of sewage, from the start to finish of work performed. Each “set-up”, regardless of location, shall have Contractor personnel on-site at all times (24 hours a day, 7 days a week) and stationed at the pumps, unless otherwise approved by Fayetteville Public Works Commission. The temporary bypass pumping system shall include:

- A minimum of one (1) redundant pump so that the temporary bypass pumping system is capable of transmitting the peak flow with the largest duty pump out of service.
- Pumps shall be provided with a means of automatic control via level sensing. Systems requiring manual starting and/or stopping shall not be allowed.
- All equipment (primary and secondary pumps) shall be equipped in a manner to keep noise to a maximum of 65 dBA at 30 feet.
- An automatic dialer (or similar) to immediately notify (in a sequential operation) Contractor and Fayetteville Public Works Commission personnel in the event of equipment failure. The automatic dialer shall be set to issue notifications prior to flow level reaching critical elevations and having a spill occur. All bypass pumps (regardless of location) shall be equipped with an automatic dialer (or similar).

The temporary bypass pumping system shall be provided in such a way as to maintain access for businesses and residences. The Contractor shall be responsible for determining the best location for the bypass equipment, and the need for any special provisions to ensure access for the residents and businesses. Such special provisions include, but are not limited to: installation of ramps, excavation and burial of the bypass lines, etc. The Contractor shall use bridges over the bypass lines, temporary lines under driveways, alternate routes, or other means to accomplish this item. The bypass plan submittal shall indicate the means of maintaining access. The Contractor bears all responsibility for the maintenance of any trenches, ramps, etc. necessary for the bypass operation.

Pumps, equipment, and bypass lines shall be continuously (24 hours a day, 7 days a week) monitored by on site Contractor personnel capable of starting, stopping, refueling and maintaining these pumps during the Work. The temporary bypass pumping system shall be provided with an automatic dialer (or other similar device) that will immediately notify (in a sequential operation) the Contractor and Fayetteville Public Works Commission in the event of equipment failure. All bypass pumps (regardless of location) shall be equipped with an automatic dialer. This automatic dialer (or similar) shall be set to issue notifications prior to flow levels reaching critical elevations and having a spill occur.

The automatic dialer shall be set to issue notifications through a sequential operation. Automatic dialers that are not set up for sequential notifications shall not be acceptable. The Contractor's personnel shall be the first to receive any notifications from the automatic dialer. The automatic dialer shall only notify the PWC personnel after all Contractor notifications have been ignored and/or not responded to. The Contractor shall properly adjust the level at which the automatic dialer initiates notification to provide adequate time for the sequential notification to occur. If the PWC personnel are notified by the automatic dialer, the PWC personnel shall assume that a spill is occurring or is imminent, and respond accordingly. The Contractor shall be responsible for all costs for the PWC to mobilize and respond to the notification, regardless if a spill occurred or not.

In some applications, it may be necessary to surcharge the system in order to ensure proper pump operation. This shall only be done when it has been determined the system can accommodate the surcharging without any adverse impact. The Contractor has the sole responsibility for determining whether the system can accommodate surcharging. In the event surcharging is necessary, the Contractor shall be responsible for continuously monitoring the system to ensure no sewer spills occur.

All bypass piping shall successfully pass a hydrostatic test prior to bypassing the sewer flows. The hydrostatic test pressure shall be no less than the expected discharge pressures, and shall be held for a minimum of one (1) hour. All testing shall be observed by Fayetteville Public Works Commission. Testing shall be coordinated with Fayetteville Public Works Commission a minimum of 24 hours in advance.

SPILL RESPONSE

The Contractor shall not discharge or pump any sewage, solids, or debris on the ground, streets, storm water system, ditches, or streams. Any sewage spills shall be immediately reported to Fayetteville Public Works Commission Water Resources Construction Department, (910) 223-4716. After normal business hours, the Contractor shall contact Fayetteville Public Works Commission Dispatch Center, (910) 678-7400 or (910) 323-0178. The Contractor shall take complete responsibility for all costs related to the clean-up of the spill, including any fines issued by the North Carolina Department of Environmental Quality (NC DEQ).

In the event that raw sewage (in any quantity) is spilled, discharged, leaked or otherwise deposited in the open environment, due to the Contractor's work, the Contractor is responsible for any cleanup of solids and disinfection of the area affected. This work will be performed at the Contractor's expense with no additional cost to Fayetteville Public Works Commission. The Contractor is also responsible for complying with any and all regulatory requirements in regards to the size spill with no additional cost to Fayetteville Public Works Commission. The Contractor shall cooperate fully with Fayetteville Public Works Commission and the applicable State agencies in responding to and cleaning up the spill. Any work completed by Fayetteville Public

Works Commission in responding to a spill caused by the Contractor's operations shall be billed to the Contractor.

Where sewage has backed up into a property due to any aspect of the Contractor's operation, the Contractor shall immediately notify Fayetteville Public Works Commission, inspect the property with Fayetteville Public Works Commission and agree on remedial measures. The Contractor shall be responsible for all cleaning, repair and/or replacement of damaged property, temporary relocation of all occupants of the affected properties, if required, all to the satisfaction of the property owner. These actions shall be undertaken immediately upon learning of the backup. Cleaning shall be performed by firms specializing in this type of work. All costs associated with the cleaning, repair, replacement of damages, occupant accommodations, insurance and spill remediation shall be borne by the Contractor. All remediation measures required as part of a spill response are part of acceptance of the project, and final payment shall not be made until such time all required measures are addressed and approved by the appropriate regulatory agency.

*** END OF SECTION ***

**DIVISION 2
SITE WORK
02764 - LIFT STATION WET WELL LINING**

GENERAL

This specification covers the work necessary to furnish and install the monolithic polymeric lining system and appurtenances, complete, as shown on the Contract Drawings and as specified herein. The lining system shall be used to rehabilitate the designated concrete lift station wet well(s), as indicated within these Contract Documents and as shown on the Contract Drawings. The installed lining system shall withstand all loading conditions and hydrostatic pressure.

The lining system shall consist of a cementitious base coat applied to the cleaned and prepared surfaces, installation of the monolithic lining system, followed by a ultra-violet (UV) resistant top coat (as applicable). The Contractor shall furnish all necessary material, labor, and equipment necessary to properly prepare the surfaces and apply the monolithic lining system as specified herein.

The Contractor is responsible for properly preparing the existing wet well for lining prior to the installation of the lining system, including stopping all leaks, patching voids, cleaning (to include water blasting), removing rubble, debris removal, etc.

The Contractor is advised that the presence or absence of any leakage through the walls as seen in the Contractor's independent inspection of the wet well prior to bidding is dependent upon the ground water levels and conditions at the time of the inspections. The Contractor shall reflect his/her assumptions and judgments on leakage through the wet well walls based on this information in the unit prices bid. All leakage shall be stopped prior to installing the lining system. No additional payment will be made to the Contractor for repairing leaks not visible prior to bidding.

Cleaning, surface preparation, lining application, and thicknesses shall be as specified herein and shall meet or exceed the lining manufacturer's recommendations. When the manufacturer's minimum recommendations exceed the specified requirements, the Contractor shall comply with the Manufacturer's minimum recommendations.

RELATED SECTIONS

- G. Section 02730 – Sanitary Sewer System
- H. Section 02750 – Wastewater Flow Control

REFERENCE STANDARDS

This Section contains references to the governing standards and documents listed below. They are a part of this Section as specified and modified; the current version shall apply unless otherwise noted. In case of conflict between the requirements of this section and those of the listed documents, the more stringent of the requirements shall prevail.

- A. American Concrete Institute (ACI)

- a. ACI 224.1R – Causes, Evaluation and Repair of Cracks in Concrete Structures
- b. ACI 301 – Specifications for Structural Concrete
- c. ACI 308R – Guide to Curing Concrete
- d. ACI 350 – Code Requirements for Environmental Engineering Concrete Structures and Commentary
- e. ACI 515 – A Guide to the use of Waterproofing, Dampproofing, Protective, and Decorative Barrier Systems for Concrete
- f. ACI 546.R – Concrete Repair Guide
- g. ACI 546.3R – Guide for the Selection of Materials for the Repair of Concrete

B. ASTM International (ASTM)

- a. ASTM C 868 – Standard Test Method for Chemical Resistance of Protective Linings
- b. ASTM C 1583/1583M – Standard Test Method for Tensile Strength of Concrete Surfaces and the Bond Strength or Tensile Strength of Concrete Repair and Overlay Materials by Direct Tension (Pull-off Method)
- c. ASTM D 2794 – Standard Test Method for Resistance of Organic Linings to the Effects of Rapid Deformation (Impact)
- d. ASTM D 4060 – Standard Test Method for Abrasion Resistance of Organic Linings by the Taber Abraser
- e. ASTM D 4285 – Standard Test Method for Indicating Water or Oil in Compressed Air
- f. ASTM D 4263 – Standard Test Method for Indicating Moisture in Concrete by the Plastic Sheet Method
- g. ASTM D 4414 – Standard Practice for Measurement of Wet Film Thickness by Notch Gages
- h. ASTM D 4541 - Standard Test Method for Pull-off Strength of Coatings Using Portable Adhesion Testers
- i. ASTM D 6944 Standard Test Method for Measuring Humidity with a Psychrometer
- j. ASTM D 7682 – Standard Test Method for Replication and Measurement of Concrete Surface Profiles Using Replica Putty
- k. ASTM F 1869 – Standard Test Method for Measuring Moisture Vapor Emission Rate of Concrete Subfloor Using Anhydrous Calcium Chloride
- l. ASTM F 2170 – Standard Test Method for Determining Relative Humidity in Concrete Floor Slabs Using in situ Probes
- m. ASTM F 2414 – Standard Practice for Sealing Sewer Manholes Using Chemical Grouting
- n. ASTM G 210 – Standard Practice for Operating the Server Wastewater Analysis Testing Apparatus

C. International Concrete Repair Institute (ICRI)

- a. Guideline No. 310.1R – Guide for Surface Preparation for the Repair of Deteriorated Concrete Resulting from Reinforcing Steel Corrosion
- b. Guideline No. 310.2 – Selecting and Specifying Concrete Surface Preparation for Sealer, Linings, and Polymer Overlays

D. National Association of Corrosion Engineers International (NACE)

- a. NACE Publication 6D-173 – A Manual for Painter Safety

- b. NACE SP0188 – Standard Practice for Discontinuity (Holiday) Testing of Protective Linings
 - c. NACE SP0892 – Standard Practice for Coatings and Linings over Concrete for Chemical Immersion and Containment Service
 - d. NACE No. 6/SSPC-SP13 – Surface Preparation of Concrete
- E. Occupational Safety and Health Administration (OSHA)
- a. Safety and health Standards (29 CFR 1910/1926)
- F. The Society for Protective Linings (SSPC)
- a. SSPC-SP13/NACE No. 6 – Surface Preparation of Concrete
 - b. SSPC-Guide 12 – Guide for Illumination of Industrial Painting Projects
- G. Standard Practice for the Rapid Evaluation of Coatings and Linings by Severe Wastewater Analysis Test (S.W.A.T.)

Unless otherwise specified, references to documents shall mean the documents in effect at the time of receipt of Bids. If referenced documents have been discontinued by the issuing organization, references to those documents shall mean the replacement documents, the last version of the document before it was discontinued.

In case of conflicting requirements between this specification and these referenced documents, the more stringent shall govern.

SUBMITTALS

Submit, in accordance with Section 01300 – Submittals and Section 01000 – Special Conditions, letters, shop drawings, and product data showing materials of construction, installation equipment and details of installation for the monolithic lining system including:

1. Product Data Sheets: Copies of current technical data for each component specified and applied as outlined in this Section.
2. Safety Data Sheets: Copies of current SDS for any materials brought on-site including all clean-up solvents, repair or resurfacing mortars and lining materials.
3. Qualification Data: Approved Installer Training Certificates from manufacturer.
4. Performance Testing Reports: Copies of test data for the entire physical, chemical, and permeation properties listed herein and as outlined within this Section.
5. Installation Instructions: Manufacturer's written installation instructions for the materials specified in this Section.
6. Construction Details: Copies of manufacturer's computer generated standard lining details for specified materials, including: leading edge termination, metal embedment in concrete, joint detail, wall-to-slab detail, pipe termination detail, and any other detail at the request of the Public Works Commission.

GUARANTEE

The installed lining system shall be guaranteed by the Contractor and Manufacturer for a period of five (5) years from the date of final acceptance. During this period, all defects discovered in the lining, as determined by the Public Works Commission, shall be repaired or replaced in a satisfactory manner by the Contractor at no cost to the Public Works Commission. All proposed repairs shall be submitted, reviewed, and approved by the Public Works Commission prior to the Contractor completing any work.

QUALITY ASSURANCE

The supplier shall be responsible for the provisions of all test requirements specified in the above referenced ASTM Standards as applicable. In addition, all lining products to be installed under this Contract may be inspected at the plant for compliance with these specifications by an independent testing laboratory provided by the Public Works Commission. The Contractor shall require the manufacturer's cooperation in these inspections. The cost of plant inspection of all lining products and materials approved for this Contract shall be borne by the Public Works Commission.

Inspections of the lining products and materials may also be made by representatives of the Public Works Commission after delivery. The lining products and materials shall be subject to rejection at any time on account of failure to meet any of the Specification requirements, even though samples may have been accepted as satisfactory at the place of manufacture. Lining materials rejected after delivery shall be marked for identification and shall be removed from the job at once.

The Contractor shall initiate and enforce quality control procedures in accordance with the applicable ASTM, National Association of Corrosion Engineers (NACE), the Society for Protective Coatings (SSPC) standards, and in accordance with the manufacturer's instructions.

Acceptable Manufacturers: A company with a minimum of five (5) years experience in manufacturing of, and providing technical service for chemical resistant systems equivalent to those specified herein.

Substrate Conditions: Do not proceed with work until the Public Works Commission's representative, a NACE Level 3 Certified manufacturer's representative, and the Contractor have approved substrate preparation and tolerances.

Pre-Coating Application Meeting: All parties, to include the owner or owner's representative, general contractor, installer, subcontractors related to coatings and the product manufacture, shall meet prior to starting the coating application to review the specification and discuss job specific needs of the project: surface preparation, hold-points, termination details, application process, scheduling of project, site visits, environmental conditions, material storage, High Voltage Holiday Detection and other needs and requirements.

Delivery, Storage, and Handling

Care shall be taken in shipping, handling and placing to avoid damaging the lining products. Extra care may be necessary during cold weather construction. Any lining product or material damaged in shipment shall be replaced as directed by the Public Works Commission.

Any lining product showing deterioration, or which has been exposed to any other adverse storage

condition that may have caused damage, even though no such damage can be seen, shall be marked as rejected and removed at once from the work.

While stored, the lining products shall be adequately packaged and protected. The lining products shall be stored in a manner as recommended by the manufacturer. The Contractor shall comply with the following:

1. Store the materials in sealed, original manufacturer's containers.
2. Store materials in a protected area out of direct sunlight.
3. Keep containers clean and undamaged.
4. Comply with manufacturer's published storage temperature and shelf life recommendations.
5. Protect all materials from freezing.

Deliver products to the job site in manufacturer's original, unopened containers bearing manufacturer's name and label and the following information

1. Product name
2. Product description (generic product classification)
3. Manufacturer's lot number
4. Color

All materials shall be handled in accordance with their Safety Data Sheets (SDS) and the manufacturer's instructions.

PRODUCTS

PART 1 - The materials to be utilized in the lining of lift station wet wells shall be designed and manufactured to withstand the severe effects of hydrogen sulfide in a wastewater environment. Manufacturer of corrosion protection products shall have a minimum of 10 years experience in the production of the lining products utilized and shall have satisfactory installation record. All rehabilitation products shall be manufactured by one manufacturer, or the supplier shall provide documentation that the materials are compatible with each other.

All lining materials shall be approved by U.S. EPA for sewer system rehabilitation.

The lining system shall be compatible with the thermal condition of the existing sewer manhole surfaces. Surface temperatures will range from 20°F to 100°F.

Any polymeric lining system that cannot provide test results of ASTM G 210 will not be approved for this application. (ASTM G 210– Standard Practice for Operating the Server Wastewater Analysis Testing Apparatus).

The polymeric lining system shall provide a minimum service life of 50 years.

INFILTRATION CONTROL MATERIAL

Prior to installing the lining system, active infiltration shall be controlled according to the specifications of the lining manufacturer. Infiltration control materials shall be rapid-setting, high early strength, hand applied cementitious material for stopping infiltrating water and making repairs to concrete, brick, or other masonry constructed wet wells. The material shall be non-shrinking, non-metallic and non-corrosive. It shall be formulated at the factory and supplied in factory sealed and labeled pre-measured containers. The material shall be compatible with the lining material to be used. The material shall have the following minimum characteristics:

1. Compressive strength	ASTM C-109	1,000 psi at 1 hour 2,400 psi at 24 hours
2. Expansion	ASTM C-827	0.10 percent
3. Set time	ASTM C-191-92	45 to 60 seconds

Infiltration control material shall be CEMTEC Hydraulic Cement by A.W. Cook Cement, Mainstay ML-10 by Madewell Products Corporation, PLS-505 by Protective Liner Systems, Quad-Plug by Quadex, Tnemec Series 217 by Tnemec, or approved equal.

Chemical sealants or grouts used to seal active manhole leaks, to patch cracks, to fill voids and to otherwise prepare the manhole surfaces for the lining installation shall be suitable for the intended purpose and shall be compatible with the lining as certified by the manufacturer.

All leaks shall be stopped prior to the installation of the lining system.

PATCHING MATERIAL

Voids in the existing walls, floors, or damaged surfaces must be repaired prior to installing the lining system. The patching material shall be a rapid setting, high early strength, corrosion resistant hand mixed and hand applied cementitious material intended for filling voids and repairing inverts in concrete. It shall be formulated in the factory and supplied in factory sealed and labeled pre-measured containers. The material shall be compatible with the lining material to be used. The material shall have the following minimum characteristics:

1. Compressive strength	ASTM C-109	3,500 psi at 24 hours
2. Shrinkage	ASTM C-596	0 percent at 90 percent relative humidity
3. Set time	ASTM C-191-92	3 to 5 minutes

Patching material shall be CEMTEC Rapid Cure Vertical Grade by A.W. Cook Cement, Mainstay ML-72 by Madewell Products Corporation, Hyperform by Quadex, Tnemec Series 218, or approved equal.

CEMENTITIOUS BASE COAT

The cementitious base coat shall be a pumpable Portland based 100% pure calcium aluminate cement. The lining shall be installed via low-pressure application only. The materials shall be suitable for all the specified design conditions.

The cementitious base coat shall be a cementitious system suitable for use as a trowel- or spray-applied monolithic surfacing in sewer wet wells. The cementitious lining system shall be Mainstay ML-CA by Madewell Products Corporation., Aluminaliner by Quadex; CEMTEC Silatec CAM by A.W. Cook Cement; PLS-507 by Protective Liner Systems, or approved equal.

The cementitious base coat shall be applied to the following minimum total thicknesses:

- 1. For block and cast concrete wet wells in good condition, apply to a minimum thickness of one-half (0.5) inch.**
- 2. For all brick wet wells and for block or cast concrete wet wells in poor condition, apply to a minimum thickness of one (1.0) inch.**

It is the Contractor's responsibility to determine the required thickness of the cementitious base coat, based on the wet well condition, groundwater conditions, etc. to ensure the long-term integrity of the installed lining system.

The cementitious base coat shall be installed on the walls of existing wet wells as shown on the Contract Drawings, from the invert to the top, as further directed below. All cementitious lining shall be troweled to consolidate the material, and then brushed to provide a profile surface for application of the polymeric topcoat. The initial trowelling shall be done in an upward motion, to compress the material into voids. The Contractor shall ensure that the cement is not over-troweled. The cured cementitious base coat surface shall be continuous with proper sealing connections to all unsurfaced areas. The Contractor shall take all measures to ensure that the cementitious base coat properly cures. The use of curing compounds is prohibited.

The materials used in the cementitious base coat shall be mixed on site in accordance with the manufacturer's recommendations. Water shall only be added to the materials during the mixing process and prior to material pumping or spray application. No water shall be added at the nozzle.

The cementitious base coat, when cured, shall have the following minimum characteristics at 28 days as measured by the applicable ASTM standards referenced herein:

1. Density (when applied) – 135 pounds/cubic foot, plus/minus 5 pounds/cubic foot
2. Compressive strength (in accordance with ASTM C-109):

1 day	2,800 psi
28 day	8,000 psi
3. Bond Strength (in accordance with ASTM C-321)

28 day	1,700 psi
--------	-----------
4. Flexural Strength (in accordance with ASTM C-78)

28 day	1,500 psi
--------	-----------
5. Shrinkage (in accordance with ASTM C-157) – 0%

6. Freeze-Thaw Durability (in accordance with ASTM C-666)
300 cycles no loss

The cured cementitious base coat shall be continuously bonded to all the brick, mortar, concrete, chemical sealant, grout, pipe and other surfaces inside the sewer wet well.

The cementitious base coat shall be prepared in accordance with the coating manufacturers written recommendations.

POLYMERIC LINING SYSTEM

Materials

The lining system shall be a polymeric system suitable for use as a trowel- or spray-applied monolithic surfacing in sanitary sewer wet wells. The polymeric lining system may be a two part 100% solids epoxy, epoxy mortar or polyurethane resin system. Accepted manufacturers are:

Epoxy Systems: Mainstay DS-5 Epoxy by Madewell Products Corporation;
PLS-614 by Protective Liner Systems;
Raven 405 by Raven Lining Systems;
Dura-Plate 5900 HB Epoxy by Sherwin-Williams;
Dura-Plate 6100 HP Epoxy by Sherwin-Williams; or approved equal

Epoxy Mortar: Dura-Plate 5900 HB Epoxy Mortar by Sherwin-Williams;
Tnemec Perma-Shield H2S; or approved equal.

Polyurethanes: Sher-Flex by Sherwin-Williams; or approved equal.

The lining system top coat shall be a 100% solids, epoxy polymer protective barrier material specifically designed to protect concrete and steel surfaces in severe wastewater environments, including associated abrasive physical attack and chemical attack from sewer gases and organic acids generated by microbial sources.

Epoxy lining shall be capable of achieving the specified thickness in a single coat application.

The polymeric top coat materials shall be applied by low pressure spray or hand applied to the minimum dry film thickness of 125 mils. The polymeric materials shall be suitable for sewer system service and chemically resistant to any chemicals or vapors normally found in domestic and/or commercial sewage. The polymeric material shall be compatible with the cementitious base coat material, as per manufacturer's recommendations.

Installation

The polymeric lining system shall be installed over the cementitious base coat previously applied on the surfaces to be lined within the existing wet well. The polymeric liner shall be applied only after the cementitious base coat has been properly cured and set sufficiently, per manufacturers recommendations.

The Contractor shall saw-cut the existing walls, benches, and/or inverts in order to "tie-in" the polymeric lining.

The cured surface of the polymeric lining system shall be smooth and continuous with proper sealing connections to all unsurfaced areas. The sprayed-on liner shall be troweled to consolidate the product into the profile of the substrate or resurfacing mortar.

When cured, the monolithic polymeric lining shall form a continuous, tight-fitting, hard, impermeable surfacing which is suitable for sewer system service and chemically resistant to any chemicals or vapors normally found in domestic sewage. The polymeric lining shall be continuously bonded to the base coat. Upon visual inspection with adequate lighting the surface of the coating shall be without pinholes. The concrete, ductile iron, carbon steel shall be thoroughly coated and properly sealed.

ULTRA-VIOLET (UV) RESISTANT COATING (if required)

The ultra-violet (UV) resistant coating system shall be an aliphatic acrylic-polyester polyurethane system suitable for use as a trowel- or spray-applied monolithic surfacing in sanitary sewer wet wells. The UV resistant coating system shall be a two part system. Acceptable systems are Sherwin-Williams SherThane 2K Urethane, Tnemec Series 73 Endura-Shield, Carboline's Carbothane 133 HB, or approved equal.

The UV resistant coating shall be applied to the minimum dry film thickness of 3 to 5 mils. The coating materials shall be suitable for all the specified design conditions. The UV resistant coating shall be compatible with the polymeric lining system, as per manufacturer's recommendations.

INSTALLATION

GENERAL

All work shall be in accordance with these Contract Documents and as directed by the Public Works Commission.

The Contractor shall take appropriate action to comply with all local, State and Federal regulations including those set forth by OSHA, EPA, the Public Works Commission and any other applicable authorities.

Prior to conducting any work, the Contractor shall perform an inspection of the structure to determine any need for protection against hazardous gases or oxygen depleted atmosphere and the need for flow control or flow diversion.

The Contractor shall properly clean the wet well to be lined and shall properly dispose of any resulting material. The Contractor shall take sufficient precautions so as to not allow any debris from their operations to enter the lift station pumping system. Debris from the cleaning operation can be directed to the wet well to facilitate removal. Utilizing the existing pumps and force main to remove the debris is not acceptable.

All surface washing, abrasive blasting, waterjetting, grinding, patching, filling and preparation shall be completed by the Contractor in accordance with the lining system manufacturer's recommendations.

Application procedures shall conform to recommendations of the manufacturer, including materials handling, mixing, environmental controls during application, safety and spray equipment. Material shall not be applied during freezing weather conditions. No material shall be placed when the ambient air temperature is below 40oF, or when the temperature is anticipated to fall below 32oF in the next 24 hours.

Spray equipment shall be specifically designed to accurately ratio and apply the liner system.

SURFACE PREPARATION

Surface preparation methods may include high pressure water cleaning, hydro blasting, abrasive blasting, grinding, detergent water cleaning, and shall be suited to provide a surface compatible for installation of the liner system. Remove all dust, biological growths, grease, oil, paint or any other surface contaminants or coatings from all surfaces to be lined, including manhole walls, corbelling and manhole frame. The choice of surface preparation lies solely with the Contractor. The Contractor shall determine the required surface preparation method based upon the condition of the manhole, the presence of potential contaminants, access to perform the work, and the required condition of the surface to apply to specified lining system, as required by the manufacturer.

The surface preparation method shall produce a cleaned, abraded and sound surface with no evidence of laitance, loose concrete, brick or mortar, contaminants or debris, and shall display a surface profile suitable for application of the manhole lining system. The Contractor shall prepare the surface in accordance with the applicable NACE and/or SSPC recommendations for the specified lining system.

Coatings that cannot be removed shall be sanded with coarse sand paper to roughen the surface sufficiently to obtain and insure adequate bonding of the cementitious base coat material.

The Contractor shall conduct a visual inspection of the wet well after it is cleaned. All active infiltration leaks shall be plugged or sealed with an appropriate grout compatible with the cementitious base coat. Remove all loose mortar and rubble from existing walls, benches and inverts. Repairs to exposed rebar, defective pipe penetrations or inverts, etc. shall be repaired utilizing non-shrink grout or approved alternative method. Prepare manhole to receive the cementitious base coat as necessary by reshaping and repairing benches, inverts, and wall where required. All interior surfaces shall be prepared as recommended by the base coat lining manufacturer. Minimum requirements are as listed below.

1. All cracks and other voids must be repaired and filled with suitable non-shrinking cements, sealants or grouts, including all voids between the existing sewer pipes and manhole walls. Patching compounds shall be compatible with the proposed lining system. All patches shall be smooth and even with the manhole wall.
2. All existing manhole rungs/steps shall be removed and the void patched or cut off and ground smooth.
3. All surfaces shall be suitably prepared for the required bonding of the cementitious base coat as recommended by the manufacturer.

Concrete surfaces to be coated shall be free of curing compounds and form release agents,

laitance and foreign particles that may inhibit bonding. Prior to the start of the protective coating system application, pre-clean as required, and inspect the substrate in accordance with SSPC-SP13/NACE No. 6, Severe Service. Surface preparation procedures shall be in accordance with NACE SP0892, SSPC-SP13/NACE No. 6 and ICRI Guideline No. 310.2. Surface preparation shall expose aggregate and obtain a uniform surface texture resembling the minimum recommended concrete surface ICRI-CSP profile. Remove all dust, biological growths, grease, oil, paint or any other surface contaminants or coatings from all surfaces to be lined, including any metal work to be coated.

Existing Concrete Application: Existing concrete structures to receive protective coating system must be capable of withstanding imposed loads. All oil, grease, waste and chemical contaminants must be removed from the surface of the concrete prior to preparation in accordance with NACE SP0892 and SSPC-SP13/NACE No. 6. Concrete surfaces must be sound and capable of supporting the proposed polymeric lining system. Surface preparation requirement is to expose a sound, uniform surface texture confirming to the minimum recommended ICRI-CSP. The appropriate cementitious repair mortar or epoxy cementitious repair material shall be applied to the entire, prepared surface to level surface suitable for coating.

Commencement of the Work of this Section shall indicate that the substrate and other conditions of installation are acceptable to the Contractor, and will produce a finished product meeting the requirements of these Contract Documents. All defects resulting from accepted conditions shall be corrected by Contractor at his own expense.

All concrete surfaces shall be prepared to a minimum of SSPC-SP13 prior to installation of the polymeric coating.

Level or grind concrete substrates to produce a uniform and smooth surface, including removal of all sharp edges, ridges, form fins, and other concrete protrusions.

Concrete surfaces to receive protective coating shall be cast with a Smooth Form Finish in accordance with ACI 301. Surfaces shall not be rubbed, sacked, troweled or otherwise finished in any manner that will obscure or cover the parent concrete surface with materials other than materials as specified in this Section.

All voids, bugholes, and other surface depressions shall be filled with the specified epoxy-modified resurfacer, re-establishing plan finished grades and concrete planes. The thin overlay shall be applied as a continuous parge coat at a minimum 1/16 inch (1.6 mm) thickness to the entire concrete surface.

Metal Application: Remove all visible contaminants per SSPC-SP1. Prepare the surfaces in accordance with SSPC/NACE surface preparation standards per the Manufacturer's instructions.

Contractor shall examine the areas and conditions under which the protective coating Work is to be performed in accordance with NACE SP0892, Table 1 and SSPC-SP13/NACE No. 6, and notify the Public Works Commission in writing of conditions detrimental to the proper and timely completion of the Work.

FLOW CONTROL

The Contractor shall be responsible for the temporary bypass pumping of sewage flows, in accordance with the requirements of these Contract Documents. The temporary bypass pumping shall be in accordance with Specification Section 02750 – Wastewater Flow Control and these Contract Documents.

INFILTRATION CONTROL

After surface cleaning, any visible leaks or infiltration shall be stopped, prior to installation of any patching material or the cementitious base coat. Infiltration and leaks shall be stopped utilizing hydraulic cement or other “typical” methods (i.e., oakum). It is the intent of these Contract Documents that the Contractor will take all necessary steps to stop all but the very large leaks without the use of chemical grout. Should a significant, very large leak be encountered that would require significant effort, large quantities of chemical grout, and/or other extreme measures, the method and cost to stop that leak would be mutually agreed upon by the Contractor and the Public Works Commission.

A complete, watertight seal shall be provided at all pipe and wet well wall connections. The Contractor shall submit details of how the watertight connections will be made to the Public Works Commission for review and approval.

CEMENTITIOUS BASE COAT

The Contractor shall furnish and place the cementitious base coat as required to provide the proper profile on the wet well walls and other surfaces to be coated, and as may be directed by the Public Works Commission. The installation of the base coat shall be in complete accordance with the manufacturers' specifications.

Prior to placing the base coat, the Public Works Commission, manufacturer’s representative, and the Contractor must inspect and approve the surface preparation work. The Contractor shall notify the Public Works Commission and manufacturer’s representative when the wet well is ready for inspection. The Contractor is responsible for ensuring proper installation conditions including surface preparation, surface temperature and surface moisture.

All bottom and horizontal surfaces shall have the base coat material applied to the required thickness by hand troweling or spray-on methods. All cementitious lining shall be troweled to consolidate the material, and then brushed to provide a profile surface for application of the polymeric topcoat. The initial trowelling shall be done in an upward motion, to compress the material into voids.

All side vertical surfaces shall have the cementitious base coat applied to the required thickness in one pass or application. Non-vertical surfaces may be completed in multiple passes to prevent sloughing of material.

Temperature limitations must be handled as appropriate and as approved by the manufacturer.

POLYMERIC TOP COAT

The Contractor shall furnish and place polymeric lining over the previously installed cementitious base coat and all other surfaces to be lined, and as may be directed by the Public Works

Commission. The installation of the polymeric lining shall be in complete accordance with the applicable provisions of the manufacturers' specifications.

The Contractor shall provide documentation that the mixing of materials is in accordance with the manufacturer's instructions.

Prior to placing the top coat, the Public Works Commission, a representative from the polymeric lining manufacturer, and the Contractor must inspect and approve the base coat. The Contractor shall notify both the Public Works Commission and the manufacturer's representative when the wet well is ready for inspection. The Contractor is responsible for ensuring proper installation conditions.

All surfaces shall have the monolithic polymeric lining applied by a spray-on method or by hand troweled applications in multiple passes to gradually build up to the required thickness.

Temperature limitations must be handled as appropriate and as approved by the manufacturer.

ULTRA-VIOLET (UV) RESISTANT COATING (as applicable)

The Contractor shall furnish and place the UV resistant coating over the previously installed polymeric lining system, and as may be directed by the Public Works Commission. The installation of the UV resistant coating shall be in complete accordance with the applicable provisions of the manufacturers' specifications.

Prior to placing the coating, the Public Works Commission, a representative from the coating manufacturer, and the Contractor must inspect and approve the polymeric lining. The Contractor shall notify both the Public Works Commission and the manufacturer's representative when the wet well is ready for inspection. The Contractor is responsible for ensuring proper installation conditions.

All surfaces shall have the coating applied by a spray-on method or by hand troweled applications in multiple passes to gradually build up to the required thickness.

Temperature limitations must be handled as appropriate and as approved by the manufacturer.

FIELD QUALITY CONTROL

The Contractor to perform the quality control procedures listed below in conjunction with the requirements of this Specification Section.

- A. Inspect all materials upon receipt to ensure that all are supplied by the approved Manufacturer.
- B. Surface pH Testing: The pH of the concrete substrate will be measured using pH indicating papers. The pH testing is to be performed once every 50 square feet. Acceptable pH values shall be a minimum 9.0 as measured using color indicating pH paper with readable color calibrations and a scale at whole numbers (minimum). Use Hydrion Insta-Check Jumbo 1-12, or approved equal. The paper shall be touched to the surface once using moderate gloved finger pressure. The surface shall not be wiped or moved laterally to disturb the

surface during pH testing. Following the one touch, lift the paper vertically to not "wipe" the surface. Compare the color indicated with the scale provided and record the pH. Spot check any questionable areas with a 1% phenolphthalein solution. The phenolphthalein solution shall turn bright pink on concrete.

- C. Surface Profile: Inspect and record substrate profile (anchor pattern). Surfaces shall be profiled, at a minimum, equal to the CSP roughness as recommended by the coating manufacturer in accordance with ICRI Guideline 310.2 and SSPC-SP13/NACE No. 6.
- D. Measure and record ambient air temperature once every two hours of each work shift using a thermometer and measure and record substrate temperature once every two hours using an infrared or other surface thermometer.
- E. Measure and record relative humidity and dew point temperature every two hours of each work shift using a sling psychrometer in accordance with ASTM E 337.
- F. Provide verification of correct mixing of coating materials in accordance with the Manufacturer's instructions.
- G. Inspect and record that the "pot life" of coating materials is not exceeded during installation.
- H. Verify curing of the coating materials in accordance with the Manufacturer's instructions.
- I. Dry-Film Thickness:
 - 1. Wet-Film Thickness shall be taken every 100 square feet in accordance with ASTM D 4414 and recorded.
 - 2. The Dry-Film Thickness can be determined using a surface area calculation for material consumption.
- J. The Contractor is responsible for keeping the Public Works Commission informed of all progress so that the Public Works Commission may provide additional quality control at their discretion.
- K. Inspection by the Public Works Commission or others does not absolve the Contractor from his responsibilities for quality control inspection and testing as specified herein or as required by the Manufacturer's instructions.

HOLD POINT INSPECTIONS

A NACE Level 3 certified technical representative of the coating manufacturer shall visit the job site and support the Contractor's personnel and/or the Public Works Commission as needed and/or requested. Visits shall be made on a weekly basis as a minimum or as needed to review hold points for the Public Works Commission. Additional visits shall be made as needed and/or requested by the Public Works Commission or Contractor. A minimum of 48 hours' notice is required by the Contractor for each hold point inspection.

The Public Works Commission will require that the coating manufacturer provide an authorized representative to verify that:

1. The wet well surface has been properly prepared, prior to installation of the cementitious base coat.
2. The cementitious base coat has been properly prepared, prior to installation of the polymeric coating.
3. The polymeric coating has been installed in accordance with the manufacturer's recommendations
4. The polymeric coating has been properly prepared, prior to installation of the UV-resistant top coat.
5. The UV-resistant coating has been installed in accordance with the manufacturer's recommendations.

It is recommended that the coating manufacturer's representative make periodic site visits, in order to respond to any questions or concerns raised by either the Public Works Commission or the Contractor, as well as to verify the proper installation of the coating system.

TESTING

During application of the polymeric coating, the Contractor shall measure the thickness and uniformity of the liner by the use of a wet film thickness gage meeting the requirements of ASTM D 4414. Field acceptance of monolithic lining system shall be based on the Public Works Commission's and manufacturer's NACE Level 3 Certified representative's evaluation of the appropriate installation of the base coat, polymeric coating, and UV-resistant coating per field inspections and on observation of the measurements of the wet film thickness. Acceptance shall also be based on the Public Works Commission's and manufacturer's representative's evaluation of the curing test data and final testing.

Field acceptance of the manhole lining system shall be based on the Public Works Commission's evaluation of the appropriate installation of the base coat and top coat per field inspections and on observation of the measurements of the wet film thickness. Acceptance shall also be based on the Public Works Commission's evaluation of the curing test data and final testing.

The polymeric lining top coat shall provide a continuous monolithic surfacing with uniform thickness throughout the manhole interior and be free of pinholes, slumps and drips. A visual inspection shall be conducted to ensure that no pinholes are in the monolithic coating. The visual inspection shall include terminations and transitions of the polymeric liner.

All lined surfaces shall be inspected via high voltage spark testing when all rehabilitation work is

complete and the UV-resistant coating is hard to the touch.

Once the lining system has fully cured, it shall be checked via high voltage spark detection, in accordance with NACE SP0188 and the manufacturer's instructions. All defects shall be corrected at no cost to the Public Works Commission. The high voltage spark detection shall be done in accordance with:

1. The manhole environment shall be properly vented prior to testing to ensure hazardous conditions do not exist.
2. The high voltage spark detection equipment shall be set at 100 volts per one (1) mil of applied film thickness, or as recommended by the manufacturer.
3. All detected holidays shall be marked and the area of the liner shall be repaired. The surface area around the defect in the liner shall first be abraded using an appropriate grit paper or other hand abrasion tool. After abrading and cleaning the area, the area shall be patched by hand application of the polymeric lining topcoat material. All repair procedures shall follow manufacturer's recommended procedures.
4. All repaired areas shall be spark tested.

The Contractor is expected to perform preliminary spark testing prior to scheduling a final test with the Public Works Commission. Any defects noted during this preliminary testing shall be repaired in accordance with these specifications and the manufacturer's recommended procedures.

ACCEPTANCE

The Public Works Commission shall complete a final inspection of the completed wet well, to include a visual inspection to verify that no leakage through the walls is occurring, the wet well has been rehabilitated in accordance with the Contract Documents, and witness the final spark test. The Public Works Commission shall visually inspect the wet well and shall observe the final spark testing for the wet well. The Contractor shall coordinate with the Public Works Commission to schedule the final inspection. Any deficiencies noted during the final inspection shall be repaired in accordance with these Contract Documents and the manufacturer's recommended procedures.

Inspection by the Public Works Commission does not absolve the Contractor from their responsibility for quality control inspection and testing as specified in these Contract Documents or as required by the manufacturer's instructions.

There shall be no groundwater infiltration or other leakage through the manhole wall after it has been lined. If leakage is found, it shall be eliminated with an appropriate method as recommended by the liner manufacturer and approved by the Public Works Commission. Any leakage shall be sealed utilizing materials compatible with the lining system, in accordance with the manufacturer's directions, and as approved by the Public Works Commission. The repair materials shall have the same life expectancy of the installed lining system. All repair materials shall be properly cured in accordance with the manufacturer's instructions. The use of curing compounds is prohibited.

All pipe connections shall be open and clear.

There shall be no cracks, voids, pinholes, slumps, drips, uncured spots, dry spots, lifts, delaminations or other type defects in the lining. The polymeric lining shall provide a continuous monolithic surface with uniform thickness throughout the wet well.

If any defective lining is discovered after it has been installed, it shall be repaired or replaced in accordance with the manufacturer's recommendations and in a satisfactory manner to the Public Works Commission. This requirement shall apply for the entire guarantee period.

At the completion of the Work, the Contractor shall remove all materials and debris associated with the Work of this Section.

The Contractor shall clean all surfaces not designated to receive the specified lining system. The Contractor shall restore all other work in a manner acceptable to the Public Works Commission.

The installed lining system shall be protected from damage until Final Acceptance of the Work. Any damage to the installed lining system shall be repaired or replaced at the discretion of the Public Works Commission, at no additional cost to the Public Works Commission.

The coating manufacturer's representative shall participate in the final inspection and provide written documentation that the completed work is in accordance with the manufacturer's recommendations. This written documentation shall be provided to the Public Works Commission no later than 10 business days after the final inspection. Final payment to the Contractor will not be made until such documentation is received by the Public Works Commission.

*** END OF SECTION ***

DIVISION 2 SITE WORK933 - LAWNS AND GRASSES (SEEDING)

GENERAL

All exposed ground surfaces that have been disturbed during construction shall be graded to original contours as practicable, shaped to drain, and free of trash and debris. Grassing shall be accomplished as soon as practicable after sections of work are completed. Seeding and/or planting shall be performed by an experienced subcontractor specializing in this type of operation, unless otherwise approved by the Public Works Commission in writing. Disturbed sections shall not exceed one mile, without prior approval by the Public Works Commission. Grassing shall be in accordance with the Contract Documents.

PREPARATION OF THE SOIL

The surface area to receive seed shall contain a minimum of four (4) inches of good, fertile, friable, organic natural topsoil loam as a base for spreading the seed. Topsoil shall be free of clumps, brush, sticks, weeds, stones, roots, trash or other objectionable material. Contractor shall insure all topsoil to be free of plants or plant parts of quackgrass, johnson grass, nut sedge, poison ivy or other noxious weeds. The Contractor shall furnish and supplement the existing topsoil at no additional costs to the Public Works Commission providing a minimum 4 inch thickness as specified. Soil preparation shall not be performed in frozen or extremely wet conditions. The finished topsoil bed shall be uniform in grade, with a yard like appearance. All changes in grade shall have a smooth, rounded peaks and valleys.

The topsoil shall be loosened and mixed to the depth of four inches (4"). Suitable equipment (cultipackers, harrows, drags) meeting the approval of the Public Works Commission shall be used. This operation shall be accomplished by cutting on one (1) foot centers parallel to the contour of the slopes. On slopes that are steeper than 2:1, both depth preparation and degree of smoothness may be reduced, if approved by the Public Works Commission, but in all cases the slope surface shall be scarified groove, trenched or punctured so as to provide a textural plane of cut forming pockets, ridges, or trenches in which seeding material can lodge. Soil preparation shall not be performed when the soil is frozen, extremely wet or in an otherwise unfavorable working condition. The soil shall be free of any substance that might inhibit plant growth. Assistance of the local agricultural agent is recommended.

Lime shall be applied at the rate of 1/2 tons per acre. 10-20-20 commercial fertilizer shall be applied at the rate of 1,000 pounds per acre and well worked in to the top four inches (4") of top soil. If hydroseeding, use 500 pounds of 10-10-10 fertilizer on slopes steeper than 1/2 horizontal to 1 vertical.

SEED MIXTURE AND SOWING THE SEED

Seed shall be seed certified to be the latest season's crop and shall be delivered in original sealed packages bearing the producer's guaranteed analysis for percentages of mixtures and pure live seed. The producer's seed label shall indicate it the minimum percent of pure live seed (which shall be 82.45 for Bermuda, 88 for Rye Grain), the minimum percent of germination in hard seed and maximum percent of weed seed (no more than 1 percent for Bermuda, 0.5 percent for Rye

Grain). Seed shall be labeled in conformance with U.S. Department of Agriculture rules and regulations under the Federal Seed Act and applicable State seed laws. Seed that has become wet, moldy, or otherwise damaged will not be acceptable.

The following seed mixture shall be used:

	<u>POUNDS OF SEED PER ACRE</u>			
	K-31 Fescue	Rye	Grain Centipede	Common Bermuda
April 15 - Sept. 1	75	-	60 (hulled)	5
Aug. 15 - Nov. 15	120	-	25 (hulled)	5
Nov. 1 - April 1 5	120	120	25 (un-hulled)	

Note: If there are differences in the seed mixture between the mixture stated in these specifications and that which is specified as part of an approved Erosion Control Plan, the seed mixture specified in the erosion control plan shall take precedence.

Where construction crosses a pasture that has been grassed, the Contractor shall re-seed the area with the same type of grass as found on the site. All highway rights-of-way, and private yards disturbed shall also be re-seeded or with the same type of grass previously found. The seed mixture specification shall be used as a guide and the Contractor is charged with the responsibility of seeding areas with the proper type of grass that matches the existing.

Seed shall be broadcast uniformly by hand or by approved sowing equipment. One half of the seed shall be sown in one direction and the remaining shall be sown at right angles to the first. Do not seed when the wind velocity exceeds five (5) miles per hour. Rake lightly into top 1/8 inch of the soil prior to compacting, with a roller not exceeding 100 pounds.

All seeded areas will be mulched with two (2) tons per acre of small grain straw or wood cellulose fiber spread uniformly, approximately 1/4 of ground should be visible to avoid smothering seedlings. Asphalt emulsion (ASTM D-977 and ASTM D-2028) shall be used to anchor the straw applied at 150 gallons per ton of straw, or crimped to stabilize. Asphalt emulsion shall be required from November 1st to March 31st. The Contractor shall take sufficient precautions to prevent mulch from entering drainage structures through displacement by wind, water or other causes and promptly remove any blockage which may occur.

SPECIAL CONSIDERATIONS

Shrubbery shall be expertly removed and carefully preserved for replanting, unless otherwise directed by the Public Works Commission adequate earth ball shall be removed to guard against damage to the root system. Shrubbery shall be replanted only after all construction is complete. The excavation made for replanting shall be six inches (6") larger in every dimension than the root ball removed. This additional space shall be filled with a mixture of one half topsoil and one half

peat moss. Care shall be taken to set the top of the ball slightly above or flush with the surrounding surface. Any shrubbery damaged or that dies shall be replaced with an equal or better plant material at the Contractor's expense.

MAINTENANCE

The Contractor shall protect and maintain grassed areas as necessary to establish a uniform turf composed of the grasses specified. The Contractor shall re-seed any bare areas and repair all eroded areas.

Watering of seeded areas will be required during periods of dry weather to promote maximum growth. The Contractor shall supplement natural rainfall to insure a minimum of one (1) inch of rainfall weekly.

Maintenance of lawns begins immediately after the area is planted and continues for the period required to establish acceptable lawns, but not less than sixty (60) days after initial seeding, or until provisional acceptance by Owner. Maintain seeded areas by watering, fertilizing, mowing, weeding and other operations such as rolling, re-grading, replanting, aerating, and mulching as required to establish an acceptable lawn free of eroded or bare areas.

ACCEPTANCE

Fifteen (15) days prior to the end of the sixty (60) day maintenance period, the Contractor shall make a written request to the Owner for an inspection and provisional acceptance of the seeded area. Failure to notify the Owner will not relieve the Contractor of the maintenance provisions required and the Contractor will continue to be responsible for the maintenance of the seeded area.

Replacement of dead seed area(s) shall be performed within seven (7) days after notification by the Public Works Commission and the maintenance period for these areas or individual lawns shall be extended for an additional sixty (60) day maintenance period. Failure to replace seeded area(s) within the specified seven (7) day period will result in the Owner having the work performed and deducting the cost from the Contract; however, the Contractor shall be responsible for the maintenance.

Final acceptance will be given upon satisfactory contract performance exhibited at final inspection and acceptance. Seeded areas are to be fully rooted prior to acceptance. The Owner shall be the sole judge as to whether or not the lawns are acceptable. Should any deficiencies be disclosed at final inspection, the Contractor shall make the necessary corrections in a timely manner and request re-inspection.

Payment to the Contractor for seeding areas will be approved once the seed has been established and meets the requirements of this paragraph of this specification.

GUARANTEE

The Contractor shall guarantee a stand of turf is considered acceptable when a live vigorous stand of permanent grass is established with growing sprouts visible at the surface showing not less than 9 seedlings of permanent grass at least 2 inches long in each square foot, and where

no gaps larger than 4 inches in diameter occur anywhere in the lawn area. Permanent grass is defined as Common Bermuda, Centipede, and Fescue.

END OF SECTION

**DIVISION 2
SITE WORK
09810 - SPECIAL COATINGS – GLASS REINFORCED EPOXY COATING**

GENERAL

This specification covers the work necessary to furnish and install the chemical resistant system, complete, as shown on the drawings and as specified herein. The Contractor shall furnish all necessary material, labor, and equipment necessary to properly prepare the surface and apply the glass reinforced epoxy lining system as shown on the Contract drawings and specified herein.

REFERENCES

The following standards are incorporated by reference into this specification. The latest edition of the reference shall be used.

- A. SSPC The Society for Protective Coatings
- B. NACE National Association of Corrosion Engineers
 - a. SSPC SP5/NACE No. 1 – White Metal Blast Cleaning
 - b. SSPC SP10/NACE No. 2 – Near White Metal Blast Cleaning
 - c. SSPC SP6/NACE No. 3 – Commercial Blast Cleaning
 - d. NACE RP0178 “Design, Fabrication and Surface Finish of Metal Tanks and Vessels to be Lined for Chemical Immersion Service”
 - e. NACE RP0188 “Discontinuity Holiday Testing of Protective Coatings”
 - f. NACE RP 6F-164 “Curing of Interior Tank Linings”
 - g. NACE RP 6F-166 “Recommended Practice for Inspection of Linings on Steel and Concrete”
- C. ASTM American Society for Testing and Materials
 - a. E-337 Test Method for Measuring Humidity with a Psychrometer
 - b. D 4414 Standard Practice for Measurement of Wet Film Thickness by Notch Gages
 - c. D 4541 Standard Test Method for Pull-Off Strength of Coatings Using Portable Adhesion Testers
 - d. D 5162 Standard Practice for Discontinuity (Holiday) Testing of Nonconductive Protective Coating on Metallic Substrates

In case of conflicting requirements between this specification and these referenced documents, this specification will govern.

QUALITY ASSURANCE

- A. Acceptable Manufacturers: A company with a minimum of 5 years experience in manufacturing of, and providing technical service for chemical resistant systems equivalent to those specified herein.
- B. Installer Qualifications: Engage only factory trained and qualified applicator that has successfully completed applications using specified materials on projects of similar size and scope.
 - a. Provide (3) three references with name, address, and telephone number.
- C. Substitutions: Manufacturers seeking approval of products other than the specified system must supply cured samples, full product information, project histories and references,

technical data with specifications, MSDS and certifications regarding conformity of performance properties from an independent testing laboratory. The product being submitted for approval must meet all requirements of the performance properties specified within this specification. Compliance with the above quality assurances must be provided in written form at least fourteen (14) days before bids are received. Written requests to consider substitute products shall be submitted to the Public Works Commission for review and approval. Omission or non-conformance of any item will result in rejection of the request.

- D. Substrate Conditions: Do not proceed with work until the Public Works Commission, chemical resistant system manufacturer's representative, the approved installation sub-contractor, and the Contractor have approved substrate preparation and tolerances.

DELIVERY, STORAGE, AND HANDLING

- 5. Deliver products to the job site in manufacturer's original, unopened containers bearing manufacturer's name and label and the following information
 - a. Product name
 - b. Product description (generic product classification)
 - c. Manufacturer's lot number
 - d. Color
- 6. Store materials in sealed original manufacturer's containers. Store materials in a protected area out of direct sunlight. Keep containers clean and undamaged. Adhere to manufacturer's published storage temperature and shelf life recommendations. Protect all materials from freezing.

PRODUCTS

The chemical resistant coating/lining system shall consist of one or more systems for steel repair and corrosion protection.

- A. Metals Repair - All holes up to 1 inch in diameter and all corrosion pits should be filled with an approved epoxy patching and surfacing compound. Thickness shall be sufficient to fill voids and restore the surface to required surface plane. The epoxy patching and surfacing compound shall be Sherwin-Williams' Steel-Seam FT910 or approved equal.
- B. Seam Seal - Riveted seams, weld seams, lap joints, and chine angle plates shall be filled with an approved epoxy patching and surfacing compound and smoothed out to obtain complete contact with the lining system. The epoxy patching and surfacing compound shall be Sherwin-Williams' Steel-Seam FT910 or approved equal.
- C. Steel surfaces to be treated shall receive application of Sherwin-Williams' SHER-GLASS FF Medium Film Lining System, Carboline Company's Carboguard 890 LT Glass Flake, or approved equal.
- D. The chemical resistant lining system shall be resistant to the chemical concentrations and temperatures commonly found in sewage.
- E. Physical Properties
 - a. Abrasion Resistance, ASTM D-4060 (CS 17): 120 mg. wt. Loss
 - b. Adhesion, ASTM D-4541: Concrete 350 psi. 100% concrete failure; Steel 1000 psi
 - c. Direct Impact Resistance, ASTM G-14: 30 inch pounds
 - d. Dry Heat Resistance ASTM D-2485: 200°F, discolors
 - e. Flexibility, ASTM D-522: 180° bend, 1" mandrel

- f. Pencil Hardness, ASTM D-3363: 4H
- g. Moisture Condensation Resistance, ASTM D-4585: 100°F, 1,000 hrs
 - i. No blistering, corrosion or rust
- h. Salt Fog Resistance, ASTM B117, 1,000 hrs
 - i. No blistering, corrosion or rust
- i. Exterior Durability, 1 year at 45° South: Excellent, chalks

SURFACE PREPARATION

- A. The NACE / SSPC Joint Surface Preparation Standards for abrasive blasting (most recent edition) are incorporated in and made a part of this specification. All references to SSPC-SP6 / NACE No. 3 and SSPC-SP10 / NACE No. 2 designate the definitions and other requirements in these documents. SSPC VIS 1-89 Visual Standard for Abrasive Blast Cleaned Steel shall be used to visually evaluate the blast cleanliness.
- B. Remove all oil and grease from surface by solvent cleaning per SSPC-SP1. Surface preparation shall be in accordance with the product manufacturer's recommendations. Abrasive blast clean all surfaces using a sharp, angular abrasive for optimum surface profile (3 mils). All surfaces to be coated shall be prepared to SSPC-SP10. Prime any bare steel the same day as it is cleaned and before flash rusting occurs. Preparation of the surface shall be in accordance with the coating/lining manufacturer's recommendations.
 - a. Inspect the surfaces to be coated. All holes in the steel surfaces or pits greater than 1/8 inch shall be repaired in accordance with the coating/lining manufacturer's recommendations.
 - b. Remove or grind down all sharp burrs, edges, and weld spatter from all steel that is to be coated. Corners and edges shall be chamfered 1/16" at a 45° angle minimum or rounded to a 1/16" radius (1/8" diameter) minimum. Abrasive blasting prior to the application of the lining materials shall restore the anchor profile.
 - c. All substrates are to be vacuumed, swept and blown down with clean, dry air to remove spent abrasive, dust and other foreign material that might interfere with the adhesion of the primer and lining.
 - d. The maximum allowable residual salt contamination, as measured with a KTA Scat Kit or equivalent field test method, immediately prior to the application of the first coat is as follows:
 - i. 5 micrograms per square centimeter (50mg/m²) most commodities up to 120°F
 - ii. 2 micrograms per square centimeter (20mg/m²) most commodities at 120°F and greater
 - iii. 2 micrograms per square centimeter (20mg/m²) for de-mineralized (de-ionized, distilled) water
 - e. Corrosion pits in the blasted steel shall be filled flush with the substrate with Sherwin-Williams Steel-Seam FT910 patching and surfacing compound, or approved equal.
 - f. Projections and lap joints on welded plates and on riveted plates to be coated shall be filled with Sherwin-Williams' Steel-Seam FT910 patching and surfacing compound or approved equal in order to smooth out the surface and provide for a smooth transition of the lining over the substrate.

APPLICATION

- A. Comply with manufacturers written installation procedures and individual product data sheet application bulletins.
- B. Two coats of the epoxy, with a minimum of 8 mil dry film thickness per application, shall be applied. The epoxy shall be allowed to properly cure between coats. The surface shall be prepared (i.e., abraded) in accordance with manufacturer's recommendations.
- C. All work shall be completed in accordance with the manufacturer's instructions and recommendations.

INSPECTION AND TESTING

- A. The Public Works Commission may require the services of an independent testing laboratory to test the installed system.
- B. If test results indicate noncompliance with the specification, the following corrective action may be required of the Contractor at no additional cost to the Public Works Commission:
 - a. Remove non-compliant systems or components
 - b. Replace the non-compliant system or components
 - c. Assume the testing expenses of the replaced system or components
- C. Minimum requirements of the chemical resistant lining system are that it be free of the following:
 - a. Uncured material
 - b. Inadequate thickness
 - c. Pinholes
 - d. Blisters
 - e. Delamination
 - f. Foreign matter
 - g. Unspecified materials
- D. Chemical resistant lining system shall be protected from damage or detrimental elements during cure and until the time of final acceptance.

END OF SECTION

16010 - ELECTRICAL, LIFT STATIONS

PART 1 - GENERAL

1.1 THE REQUIREMENT

- A. Furnish all labor, materials, equipment and incidentals required for a complete electrical installation for the Work associated with the Contract Documents, as hereinafter specified and shown on the Drawings. It is the intent of these Specifications that the electrical system shall be suitable in every way for the service required. All material and all work which may be reasonably implied as being incidental to the work of this Section shall be furnished at no extra cost. All workmanship shall be of the highest quality; sub standard work will be rejected.
- B. Certain equipment will be furnished as specified in other sections of these Specifications which will require mounting and wiring thereto and/or complete installation as indicated. All materials necessary for the complete installation shall be furnished and installed by the Contractor to provide complete power, lighting, communication systems, instrumentation, wiring, and control systems as indicated on the Drawings and/or as specified herein.
- C. Provide complete grounding systems for all equipment and structures as required by the National Electric Code (NEC), as specified herein, shown on the contract documents, and as required for specific pieces of equipment per manufacturer.
- D. The work shall include complete testing of all equipment and wiring at the completion of the work and making any minor connection changes or adjustments necessary for the proper functioning of the system and equipment.
- E. Electrical work shall conform to the construction schedule and progress of other trades. All power interruptions to existing equipment shall be at the PWC's convenience. Each interruption shall have prior approval.

1.2 RELATED WORK SPECIFIED ELSEWHERE

- A. Mount and wire control panels and process instruments furnished under other Divisions of these Specifications unless specifically stated otherwise. For process instrumentation, furnish and install all conduit, wire and interconnections between primary elements, transmitters, local indicators, surge protection devices and receivers.
- B. Mount and wire electric heaters, and heat tracing furnished under other sections of this Specification.

C. Lift Station Specifications

1. Refer to the equipment and controls specified within the following applicable lift station specifications:
 - a. Section 02753 Submersible Pump Lift Station
 - b. Section 02754 Self-Priming Lift Station

D. Remote Telemetry

1. Refer to the equipment and controls specified within the Specification Section 13446 Remote Telemetry, Lift Stations.

E. Additional related sections include but are not necessarily limited to the following:

1. Division 0 - Bidding Requirements, Contract Forms, and Conditions of the Contract.
2. Division 1 - General Requirements.
3. Section 03301 – Concrete Construction

1.3 CODES AND STANDARDS:

A. The electrical system and associated equipment shall comply with the following codes and standards as well as any others within the specifications and drawings.

1. Applicable federal, state, county, and municipal code requirements.
2. PWC Water Resources Manual for the Design and Construction of Water and Wastewater System Extensions
3. Applicable standards of the National Fire Protection Association (NFPA)
 - a. National Electrical Code (NEC).
 - b. National Electric Safety Code
4. American Iron and Steel Institute (AISI):
 - a. Steel Products Manual - Stainless and Heat Resisting Steel.
5. American Society for Testing and Materials (ASTM):
 - a. A36, Specification for Structural Steel.
 - b. A153, Zinc Coating (Hot-Dip) on Iron and Steel Hardware.
 - c. D698, The Moisture-Density Relations of Soils using a 5.5 LB Rammer and a 12-inch Drop.
6. Factory Mutual System (FM):
 - a. A Guide to Equipment, Materials and Services.
7. Institute of Electrical and Electronics Engineers (IEEE):

- a. 141, Recommended Practice for Electrical Power Distribution for Industrial Plants.
 - b. 242, Recommended Practice for Protection and Coordination of Industrial and Commercial Power Systems.
 8. National Electrical Manufacturers Association (NEMA):
 - a. 250, Enclosures for Electrical Equipment (1000 V Maximum)
 - b. ICS 6, Enclosures for Industrial Control and Systems
 9. National Fire Protection Association (NFPA):
 - a. 70, National Electrical Code (NEC).
 - b. 70E, Standard for Electric Safety in the Workplace
 - c. 79, Electrical Standard for Industrial Machinery
 - d. 820, Standard for Fire Protection in Wastewater Treatment and Collection Facilities
 10. Underwriters Laboratories, Inc (UL):
 - a. 508, Industrial Control Equipment
 - b. 508A, Industrial Control Panels
 - c. 698, Industrial Control Equipment for Use in Hazardous Locations.
- B. When a specific code or standard has not been cited, the applicable codes and standards of the following code-making authorities and standards organizations shall apply:
1. American Association of State Highway and Transportation Officials (AASHTO).
 2. American Iron and Steel Institute (AISI).
 3. American National Standard Institute (ANSI).
 4. American Society for Testing and Materials (ASTM).
 5. ETL Testing Laboratories, Inc (ETL).
 6. Insulated Cable Engineers Association (ICEA).
 7. Institute of Electrical and Electronic Engineers (IEEE).
 8. Illuminating Engineering Society of North America (IES).
 9. Instrument Society of America (ISA).
 10. Lightning Protection Institute (LPI).
 11. National Electrical Manufacturers Association (NEMA).
 12. National Fire Protection Association (NFPA).
 13. Occupational, Health and Safety Administration (OSHA).
 14. Underwriters Laboratories Inc (UL).
- C. In case of conflict or disagreement between codes, standards, laws, ordinances, rules, regulations, drawings and specifications, or within either document itself, the more stringent condition shall govern.

1.4 AREA CLASSIFICATIONS

- A. Outdoor Areas: Those locations on the project site where the equipment is normally exposed to wind, dust, rain, snow, etc. Outdoor areas include areas protected by a roof or rain/sun shields but not enclosed within four walls of a structure. Outdoor locations may contain wet, corrosive and hazardous areas:
1. Corrosive and hazardous areas are specified herein or identified on the Drawings. Areas not identified as such shall be considered wet.
- B. Indoor Areas: Those locations on the project site where the equipment is normally protected from wind, dust, rain, snow, etc. Indoor locations may contain unclassified, damp, wet, corrosive and hazardous areas:
1. Damp, wet, corrosive and hazardous areas are specified herein or identified on the Drawings. Areas not identified as such, but provided with heating shall be considered unclassified. Areas not identified as such, but provided without heating shall be considered damp.
- C. Hazardous Locations:
1. Hazardous locations shall be as defined in NFPA 70 NEC, NFPA 820 Standard for Fire Protection in Wastewater Treatment and Collection Facilities, and other applicable standards or codes governing the classification of a particular type of facility or location. In addition, areas are classified as shown on drawings and as follows:
 - a. Class I Division 2 areas are identified on Drawings and at the following locations:
 - 1) Residential Only Wastewater (Sewer) Pump Station Wetwells. Systems of 5 or less residences are not classified as a hazardous location.
 - 2) Wastewater Pump Station Drywells.
 - 3) Dry areas of enclosed wastewater piping (i.e. valve vaults, meter vaults, etc.).
 - b. Class I Division I areas are identified on Drawings and at the following locations:
 - 1) Wastewater Pump Station Wetwells.

1.5 SUBMITTALS:

- A. **Every submittal with any deviations or exceptions from Contract Documents shall have a separate section entitled "Requested Deviations from Electrical System Specifications"** which shall clearly define and explain all deviations and

exceptions to this specification and corresponding drawings detailing the electrical system requirements.

B. Shop Drawings:

1. **Shop drawings shall be arranged and labeled according to specifications section and/or contract documents.**
2. Submit shop drawings prior to purchase or fabrication of equipment. See individual specification sections for specific requirements.
3. Prior to submittals of shop drawings, coordinate electrical equipment, particularly motor control equipment, control panels, and instrumentation, with all applicable equipment and systems interfacing with that equipment.
4. Submittals shall be made in the following combinations:
 - a. Conduits, busway, wireway, cable tray, ductbank details, wire and cable 600 V and below, boxes, fittings, and wiring devices.
 - b. Motor control centers and control equipment, low voltage switchboards, safety switches, dry-type (specialty) transformers, panelboards, power factor correction capacitors, grounding.
 - c. Lamps, interior lighting, exterior building lighting, site lighting.
 - d. Provide a conductor identification schedule for all power, control, communication and protective circuits. The schedule shall include the following information:
 - 1) Conductor identification number.
 - 2) Conductor size.
 - 3) Number of conductors.
 - 4) Type of conductor.
 - 5) Size of conductor.
 - 6) Size of conductor usage descriptions.
 - 7) Conductor run (to and from).
 - 8) Conduit size and type.
5. For each product, clearly identify manufacturer by name.
6. Provide manufacturer's technical information on products to be used, including:
 - a. Product descriptive bulletin.
 - b. Electrical data pertinent to the project and necessary to assure compliance with Specifications and Drawings.
 - c. Equipment dimensions, where applicable.
 - d. Evidence that the products submitted meet the requirements of the standards referenced.
7. When general data sheets are provided as part of the submittal, specifically identify the products to be used on this project.
8. Ensure that all submittals clearly indicate the equipment is UL or ETL listed or is constructed utilizing UL or ETL listed or UL recognized

components. Where a UL standard has not been established clearly identify that no UL standard exists for that equipment.

9. For all equipment, provide manufacturer's installation instructions.
- C. Two copies of manufacturer's warranties.
- D. When a quality standard has been established by identification of a specific manufacturer or catalog number, submittals for proposed alternates and substitutions shall include:
1. Alternate and substitute equipment cross-referenced to the equipment it is replacing. Submittal shall be marked to show how differences will be accommodated.
 2. Calculations and other detail data to allow determination of alternate and substitute equipment equivalency to the equipment it is replacing. Data supplied shall allow detailed comparison of all significant characteristics upon which the design equipment is based.
 3. Dimensioned drawings, of the same or larger scale as the Contract Drawings, for all alternate and substitute equipment, which differs in size, configuration, service accessibility or in any significant way from the equipment it is replacing.
 - a. Complete system layout, except that portion which is identical to the Contract Document Drawings.
 - b. Redesign and modifications to all work required by the alternate or substitute equipment.
- E. Operation and Maintenance Manuals: Shall be submitted according to the individual specification section, contract drawings, and/or contract documents.
- F. Record Drawings:
1. The Contractor shall maintain a marked up set of Contract Document Drawings showing actual installed circuit numbers, conduit sizes, cable tray routing, number of conductors, conductor sizes (other than #12) and all other deviations from the design drawings.
 2. All underground conduit and concealed items shall be dimensioned on the Drawings from permanent, visible, building features.
 3. Provide actual motor size, starter size, and heater size, along with all other protective equipment for all motor circuits as part of the one-line record drawings.
 4. Revise all conductor identification and circuit schedules to indicate as installed conditions.

1.6 DELIVERY, STORAGE, AND HANDLING

- A. The Contractor shall unload and handle materials using methods, rigging, and equipment that will prevent damage to the materials. Care shall be used to prevent damage to painted and galvanized surfaces.
 - 1. Bare wire rope slings shall not be used for unloading and handling materials and equipment, except with the specific written permission of the Engineer.
- B. Stored equipment and materials shall be adequately supported and protected to prevent damage.
 - 1. Stored materials and equipment shall not be allowed to contact the ground.
 - 2. Equipment and materials which incorporate electrical equipment or which have finished painted surfaces, and other items which would be damaged by outdoor exposure, shall be stored indoors.
 - a. Provide covering and shielding for all equipment to protect from damage.
 - b. When such storage would present an unreasonable building space or volume requirement, the equipment or materials may, when acceptable to the Engineer, be stored under weatherproof coverings on shoring or platforms.
 - 3. All small loose items that could be easily lost, stolen, broken, or misused shall not be stored on open platforms or shoring.
 - 4. All storage methods and schedules shall be acceptable to the Engineer.
- C. Ensure that equipment is not used as steps, ladders, scaffolds, platforms, or for storage-either inside or on top of enclosures.
- D. Protect nameplates on electrical equipment to prevent defacing.
- E. Repair, restore or replace damaged, corroded and rejected items at no additional cost to the PWC.

PART 2 - PRODUCTS

2.1 GENERAL REQUIREMENTS:

- A. In accordance with North Carolina Building Code Council, all electrical utilization equipment furnished and installed under this Contract, including all electrical, instrumentation, and equipment control panels, instrument devices, power distribution equipment, electric valve actuators, and miscellaneous electrical devices, shall bear the label of a North Carolina approved nationally recognized

testing laboratory (NRTL). The label shall convey the laboratory's declaration of the equipment safety and suitability for intended use on this project. A list of the approved testing laboratories per equipment type is available at the following web address:

www.ncdoi.com/OSFM/Engineering/BCC/engineering_bcc_third_party.asp

- B. Shop Fabricated: Manufactured or assembled equipment for which a UL test procedure has not been established. When equipment is shop fabricated for the project, the electrical devices and enclosures utilized shall be UL or ETL listed and labeled or shall be UL recognized.
- C. Outdoor equipment may be subjected to wind, rain, lightning, and corrosives in the environment with ambient temperatures from -20 to 40 degrees C and relative humidity from 10 to 95 percent. All supports, brackets and interconnecting hardware shall be aluminum, 304 or 316 stainless steel, or as shown on the installation detail drawings.
- D. Trade names and catalog numbers may be used in the Drawings or Specifications to establish quality standards and basics of design.
- E. Layout dimensions will vary between manufacturers and the layout area indicated on the drawings is based on typical values. Contractor shall review the contract drawings, the manufacturer's layout drawings and installation requirements, and make any modifications required for proper installation subject to acceptance by Engineer.
- F. Shop or Factory Finishes: Interiors of other painted equipment shall be either white or light gray.
- G. Enclosures for Use with Electrical Equipment shall be provided as follows unless specifically shown or specified elsewhere in the Contract Documents:
 - 1. NEMA 12: Use in unclassified indoor locations.
 - 2. NEMA 3R: Use with non-electronic equipment in wet outdoor locations protected from weather by means of a roof or rain/sun shield as approved by the Engineer.
 - 3. NEMA 4:
 - a. Use in wet indoor locations.
 - b. Use in wet outdoor locations. Enclosed electronic equipment shall be provided with rain/sun shields.
 - 4. NEMA 4X: Use in all corrosive locations.
 - a. Nonmetallic enclosures shall not be used in areas subject to physical damage or sun without approval by the Engineer.

- b. Outdoor locations for enclosed electronic equipment shall be provided with rain/sun shields.
- 5. NEMA 7: Use in all Class I, Division {1}{2}, Group {A}, {B},{C},{D} locations.
 - a. Unless other enclosures are approved and UL listed for the application.
- 6. NEMA 9: Use in all Class II, Division {1}{2}, Group {E}{F}{G} and Class III, Division {1}{2} locations.
 - a. Unless other enclosures are approved and UL listed for the application.
- 7. Exceptions:
 - a. As modified in other specification sections.
 - b. As otherwise indicated on the Drawings.

2.2 WIRE AND CABLE

- A. The wire and cable to be furnished and installed for this project shall be the product of manufacturers who have been in the business of manufacturing wire and cable for a minimum of ten (10) years. It is intended to be standard equipment of proven performance as manufactured by the Okonite Company, BICC Industrial Cable Company (Cablec), or approved equal. Wire and cable shall be designed, constructed and installed in accordance with the best practices of the trade, and shall operate satisfactorily when installed as specified herein and shown on the Drawings. Only one manufacturer for each cable type shall be permitted.
- B. 600 Volt Power Wire and Cable: 600 volt power cable and wire shall consist of stranded, copper conductor with insulation rated THHN, 90°C for wet locations and THWN, 75°C for dry locations. 600 volt cable and wire for below grade service entrances or below grade runs between structures shall consist of stranded, copper conductor with insulation rated XHHN-2, 90°C for wet or dry locations. Conductors shall be tin or alloy coated, stranded copper per ASTM-B8, B-33 and B-189, Class B or C stranding contingent on the size unless otherwise specified. Minimum size wire shall be No. 12 AWG. Uncoated conductors shall only be allowed if specifically accepted by the Engineer. 600 volt individual power wire and cable shall be Okoseal-N as manufactured by the Okonite Company, BICC Industrial Cable Company (Cablec) equivalent, or approved equal. Multi-conductor power cables shall be Okoseal-N Type TC Cable as manufactured by the Okonite Company, BICC Industrial Cable Company (Cablec) equivalent, or approved equal.
- C. 600 Volt Control Cable: 600 volt control cable shall consist of stranded, copper conductor with insulation rated THHN, 90°C for dry locations and THWN, 75°C for wet locations. The individual conductors of the multiple conductor cable shall

be color coded for proper identification. Color coding shall be equal to ICEA S-68-514, Table K-1. Cables shall meet requirements of IEEE-383. Conductors shall be tin or alloy coated stranded copper per ASTM B-8 and B 33 or B-189, Class B or C stranding contingent on the size unless otherwise specified. Minimum wire size shall be No. 14 AWG. Uncoated conductors shall only be allowed if specifically accepted by the Engineer. 600 volt individual conductor control wire shall be Okoseal-N as manufactured by the Okonite Company, BICC Industrial Cable Company (Cablec) equivalent, or approved equal. Multi-conductor control cable shall be Okoseal-N Type TC Cable as manufactured by the Okonite Company, BICC Industrial Cable Company (Cablec) equivalent, or approved equal.

- D. Lighting and Receptacle Wire and Cable: The lighting and receptacle branch circuit wire shall consist of stranded, copper conductors with insulation rated THHN, 90°C for wet locations and THWN, 75°C for dry locations. Conductors shall be tin or alloy coated, stranded copper per ASTM-B8, B-33 and B-189, Class B or C stranding contingent on the size unless otherwise specified. Minimum size wire shall be No. 12 AWG. Uncoated conductors shall only be allowed if specifically accepted by the Engineer. Lighting and receptacle cables and wire shall be Okoseal-N as manufactured by the Okonite Company, BICC Industrial Cable Company (Cablec) equivalent, or approved equal.
- E. Instrumentation Cable: The instrumentation cable for analog signals shall be individually shielded twisted pair cable (TSP) or individually shielded twisted multi-pair cable (M#TSP, where # = number of pairs). Conductors shall be tin or alloy coated, soft, annealed copper, 16 AWG minimum with a minimum of 19 strands with 600 volt insulation rated for 75°C. Pairs shall have 100% coverage foil shields with a 18 AWG tinned copper drain wire. Outer jackets shall be chromed PVC. The instrumentation cable shall be Belden 8719 or Okonite Okoseal-N Type P-OS for single pair applications and Okonite Okoseal-N Type SP-OS for multiple pair applications, or approved equal.

2.3 CONDUIT AND RACEWAYS

- A. Rigid Steel Conduit (RGS): Rigid steel conduit shall be heavy wall, hot-dip galvanized, shall conform to ANSI C80.1, and shall be manufactured in accordance with UL 6.
- B. Liquidtight Flexible Metal Conduit (LT): Liquidtight flexible metal conduit shall be hot dip galvanized steel, shall be covered with a moistureproof polyvinyl chloride jacket, and shall be UL labeled. Refer to PVC-Coated Rigid Steel Conduit for fittings, condulets, and mounting accessories in non indoor dry areas.
- C. Rigid Nonmetallic Conduit (PVC): PVC conduit shall be heavy wall, Schedule 80, UL labeled for aboveground and underground uses, and shall conform to NEMA TC 2 and UL 651. PVC conduit shall be rated for direct sunlight exposure, 90°C wire, and fire retardant with low smoke emission.
- D. PVC-Coated Rigid Steel Conduit (RGS-PVC): The conduit shall be rigid steel. Before the PVC coating is applied, the hot dip galvanized surfaces shall be

coated with a primer to obtain a bond between the steel substrate and the coating. The PVC coating shall be bonded to the primed outer surface of the conduit. The bond on conduit and fittings shall be stronger than the tensile strength of the PVC coating. The thickness of the PVC coating shall be at least 40 mils.

A chemically cured two-part urethane coating, at a nominal 2 mil thickness, shall be applied to the interior of all conduit and fittings. The coating shall be sufficiently flexible to permit field bending the conduit without cracking or flaking of the coating.

Every female conduit opening shall have a PVC sleeve extending one conduit diameter or 2 inches, whichever is less, beyond the opening. The inside diameter of the sleeve shall be the same as the outside diameter of the conduit before coating. The wall thickness of the sleeve shall be at least 40 mils.

All fittings, condulets, mounting hardware, and accessories shall be PVC coated. All hollow conduit fittings shall be coated with the interior urethane coating described above. The screw heads on condulets shall be encapsulated by the manufacturer with a corrosion-resistant material.

PVC coated rigid steel conduit shall be manufactured by Ocal, Perma-Cote, Robroy, or approved equal.

2.4 BURRIED ELECTRICAL WARNING TAPE

- A. All buried conduits, wire, and ductbanks shall be provided with warning tape. Warning tape shall be constructed of 3.5 mils thick x 6 inches wide polyethylene with a magnetic layer, have a tensile strength of 1750 psi, and have a continuous preprinted permanently imbedded warning message.

2.5 JUNCTION BOXES, PULL BOXES, AND GUTTERS

- A. Indoor boxes (larger than switch, receptacle, or fixture type) and gutters shall be constructed of sheet steel, shall be galvanized after fabrication, and shall be rigidly supported by hot-dip galvanized hardware and framing materials, including nuts and bolts.
- B. Indoor boxes and gutters in corrosive or wet areas indicated on the drawings and outdoor boxes and gutters shall be NEMA Type 4X, ABS or stainless steel and shall be rigidly supported by PVC coated or stainless steel framing materials. Mounting hardware, which includes nuts, bolts, and anchors, shall be stainless steel. All damaged coatings shall be repaired according to the manufacturer's instructions.
- C. Bolt on box covers with any dimension larger than 3 feet or heavier than 25 lbs shall have rigid handles. Covers larger than 3 by 4 feet shall be split.

2.6 DISCONNECT / SAFETY SWITCHES

- A. Unless otherwise specified or shown, each disconnect switch shall be 3 pole, nonfusible, 600 volts, with a continuous current rating as indicated on the drawings.
- B. Switches shall be NEMA Type HD, heavy duty, single throw, externally operated, fused or non-fused as required. Switches shall have high conductivity copper, visible blades; nontearable, positive, quick make, quick break mechanisms; and switch assembly plus operating handle as an integral part of the enclosure base. Each switch shall have a handle whose position is easily recognizable and which can be locked in the "Off" position. The "On" and "Off" positions shall be clearly marked. Switches shall have defeatable door interlocks that prevent the door from being opened while the operating handle is in the "On" position.
- C. Disconnect Switches shall be provided in following enclosures as a minimum based on their location. Multiple ratings of enclosures may apply.
 - 1. Indoor dry areas: NEMA 1A
 - 2. Indoor damp areas: NEMA 12
 - 3. Corrosive or indoor wet process areas: NEMA 4X 304 stainless steel or non-metallic
 - 4. Outdoor areas: NEMA 12/3R with exterior rain / sun shield that covers back of enclosure and extends at least 18 inches from sides and front; otherwise NEMA 4X in outdoor areas.
 - 5. Hazardous areas: suitable for the Class, Division, and Group to suit the application.
- D. A complete set of fuses for all switches shall be furnished and installed as required. Time current characteristic curves of fuses serving motors or connected in series with circuit breakers shall be coordinated for proper operation. Fuses shall have voltage rating not less than the circuit voltage. When equipment is shop fabricated for the Project, the electrical devices and enclosures utilized shall be UL or ETL listed and labeled or shall be UL recognized.
- E. Switches shall be manufactured by Square D, Cutler-Hammer, General Electric, or approved equal.

2.7 SEPARATELY ENCLOSED CIRCUIT BREAKERS

- A. Unless otherwise specified or shown, circuit breakers shall be 3 pole, 480 volt, molded case circuit breakers of not less than 25,000 amperes interrupting rating at 480 volts AC, complete with thermal and instantaneous trip elements.
- B. Breaker enclosures shall have NEMA designations appropriate for the locations where they will be installed. NEMA Type 4X stainless steel enclosures shall be provided for outdoor locations. Each breaker shall be manually operated with a quick make, quick break, trip free toggle mechanism. Bimetallic thermal elements shall withstand sustained overloads and short circuit currents without injury and without affecting calibration.

- C. Circuit breakers shall have an operating handle as an integral part of the enclosure base. Each circuit breaker shall have a handle whose position is easily recognizable and which can be locked in the "Off" position. The "On" and "Off" positions shall be clearly marked. Circuit Breakers shall have defeatable door interlocks that prevent the door from being opened while the operating handle is in the "On" position.
- D. Circuit breakers shall be provided in following enclosures as a minimum based on their location. Multiple ratings of enclosures may apply.
 - 1. Indoor dry areas: NEMA 1A
 - 2. Indoor damp areas: NEMA 12
 - 3. Corrosive or indoor wet process areas: NEMA 4X 304 stainless steel or non-metallic
 - 4. Outdoor areas: NEMA 12/3R with exterior rain / sun shield that covers back of enclosure and extends at least 18 inches from sides and front; otherwise NEMA 4X in outdoor areas.
 - 5. Hazardous areas: suitable for the Class, Division, and Group to suit the application.
- E. Circuit Breakers shall be manufactured by Square D, Cutler-Hammer, General Electric, or approved equal.

2.8 PANELBOARDS

- A. Each lighting or power panel shall be a dead front, 120/240 volt, single phase or 120/208 volt, three phase panelboard with circuit breakers in accordance with the drawings and as specified.
- B. Cabinet: The panel shall have a flush-mounted or surface-mounted enclosure with a NEMA designation appropriate for the location where it will be installed. The enclosure shall have a door with latch and lock. At the completion of the contract, a neatly printed or typed directory listing the panel and circuit identities shall be mounted inside the door.
- C. Circuit Breakers: Circuit breakers shall be thermal magnetic, bolt in, individually front replaceable, and shall indicate "On", "Off", and "Tripped". Breakers indicated as multiple pole shall be common trip type. Breakers up to 240 volts shall have interrupting ratings not less than 22,000 amperes. Breakers for 277 volts shall have interrupting ratings not less than 25,000 amperes. Breakers for 480 volts shall be rated 600 volts, with interrupting ratings not less than 25,000 amperes at 480 volts. Handle clips to prevent casual operation of breakers shall be provided for 10 percent (at least two) of the breakers and applied to the circuits directed.
- D. Buses: The panel shall have main and neutral buses insulated from the cabinet, and a ground bus. Buses shall be copper, with ampere ratings and main lugs or breaker as indicated. The ground bus shall be similar to a neutral bus and shall have a good ground connection to the cabinet, a removable bond to the neutral

bus, clamp type lugs for the ground cable in each supply conduit, and connections for a ground cable in each load conduit.

- E. Panelboards shall be manufactured by Square D, Cutler-Hammer, General Electric, or approved equal.

2.9 LIGHTING AND AUXILIARY POWER TRANSFORMERS

- A. Separately mounted transformers shall be provided in the phases, kVA, and voltages indicated on the drawings. Transformers shall be self air cooled, dry type, wall- or floor mounted, and enclosed for wiring in conduit. Transformers installed outdoors shall be weatherproof. Transformers shall have at least two full capacity voltage taps. Transformers shall meet NEMA TP1 guidelines for energy efficiency.

2.10 POWER CENTERS

- A. Power centers shall consist of a primary breaker, a 480-120/240 volt or 480-120/208 volt transformer, a secondary breaker, and a distribution panelboard in a NEMA Type 3R enclosure. Transformer and circuit breaker configuration and ratings shall be as indicated on the drawings.
- B. Transformers: Transformers shall be self-air-cooled, dry type. Transformers shall have at least two full capacity voltage taps.
- C. Circuit Breakers: Circuit breakers shall be thermal-magnetic, bolt in, individually front replaceable, and shall indicate "On", "Off", and "Tripped". Breakers and provisions for future breakers shall be provided in the quantities, poles, and ampere ratings indicated on the drawings. Breakers shall be single pole, 20 amperes, except as indicated otherwise.

2.11 LIGHTING

- A. Refer to light fixture schedule on the drawings.

2.12 OUTDOOR ELECTRICAL EQUIPMENT RACKS

- A. Refer to outdoor equipment rack detail drawing.

PART 3 – EXECUTION

3.1 POWER AND SERVICE ENTRANCE

- A. Contractor shall consult the local electric utility regarding their service installation requirements, and shall furnish the service equipment in compliance with these requirements. Contractor shall install all power service equipment components except for components installed by the utility as directed in the utility service installation requirements.

- B. Power service equipment to be furnished by Contractor shall include, but is not limited to, meter board, meter socket, meter test cabinet, meter transformer cabinet, disconnecting means, grounding materials, riser conduits, and other service entrance fittings required by the utility and for compliance with local codes and regulations.
- C. Contractor shall also provide trenching and backfill, conduits, service cables, and other underground service entrance fittings required by the utility for underground service installation.
- D. A weatherhead shall be provided on each service riser conduit.

3.2 INSTALLATION

- A. Equipment shall be installed in accordance with the requirements of the NEC.
- B. Coordinate the installation of electrical equipment with other trades.
 - 1. Arrange for the building in of equipment during structure construction.
 - 2. Where equipment cannot be built-in during construction, arrange for sleeves, box-outs, openings, etc., as required to allow installation of equipment after structure construction is complete.
- C. Verify that equipment will fit layouts indicated.
- D. Equipment Dimensions and Clearances:
 - 1. Do not use equipment that exceeds the indicated dimensions, except as approved in writing by the Engineer.
 - 2. Do not use equipment or arrangements of equipment that reduce required clearances or exceed the space allocation.
- E. Install equipment in accordance with the manufacturer's instructions.
- F. Equipment Access:
 - 1. Install equipment so it is readily accessible for operation and maintenance.
 - 2. Equipment shall not be blocked or concealed.
 - 3. Do not install electrical equipment such that it interferes with normal maintenance requirements of other equipment.
- G. Equipment shall be installed plumbed, square and true with the structure construction and shall be securely fastened.
- H. Outdoor wall-mounted equipment shall be provided with corrosion-resistant spacers to maintain 1/4 inch separation between the equipment and the wall.
- I. Screen or seal all openings into outdoor equipment to prevent the entrance of rodents and insects.

- J. Equipment fabricated from aluminum shall not be placed in direct contact with earth or concrete.
- K. Provide all necessary anchoring devices and supports.
 - 1. Use supports as detailed on the Drawings and as specified. Where not detailed on the Drawings or specified, use supports and anchoring devices rated for the equipment load and as recommended by the manufacturer.
 - 2. Supports and anchoring devices shall be rated and sized based on dimensions and weights verified from approved equipment submittals.
 - 3. Hardware shall be malleable type, corrosion resistant and shall be supported by heavily plated machine screws or brass, bronze or stainless steel bolts.
 - 4. Do not cut, or weld to, building structural members.
 - 5. Do not mount safety switches and external equipment to other equipment enclosures, unless enclosure-mounting surface is properly braced to accept mounting of external equipment.
- L. Contractor shall verify exact rough-in location and dimensions for connection to electrical items furnished by others.
 - 1. Shop drawings shall be secured from those furnishing the equipment.
 - 2. Proceeding without proper information may require the Contractor to remove and replace work that does not meet the conditions imposed by the equipment supplied, at no cost to the Owner.
 - 3. Provide sleeves wherever openings are required through new concrete or masonry members. Place sleeves accurately and coordinate locations with the Engineer.
 - 4. Should any cutting and patching be required on account of failure of the Contractor to coordinate penetrations, such cutting and patching shall be done at the sole expense of the Contractor.
 - a. Contractor shall not endanger the stability of any structural member by cutting, digging, chasing, or drilling and shall not, at any time, cut or alter the work without the Engineer's written consent.
 - i. Provide additional reinforcing if required.
 - ii. Cutting shall be done neatly using proper tools and methods.
 - b. Subsequent patching to restore walls, ceilings, or floors to their original condition shall be done by workmen skilled in their particular field.
- M. Provide concrete foundations or pads required for electrical equipment as indicated or specified.

1. Floor-mounted equipment shall be mounted on a four (4) inch high concrete housekeeping pad. Pad shall be poured on top of the finished floor or slab.
- N. To avoid interference with structural members and equipment of other trades, it may be necessary to adjust the intended location of electrical equipment. Unless specifically dimensioned or detailed, the Contractor may, at his discretion, make minor adjustments in equipment location without obtaining the Engineer's approval. Deviations in equipment location that are specifically dimensioned or detailed, or exceed those defined above require the Engineer's prior approval.
- O. Device Mounting Schedule:
1. Dimensions are to center of item unless otherwise indicated.
 2. Mounting heights as indicated below unless otherwise indicated on the Contract Drawings:
 - a. Light switch: 48 IN.
 - b. Receptacle in all other locations: 48 IN.
 - c. Disconnect / Safety switch: 54 IN.
 - d. Panelboard (to top): 72 IN.
 - e. Motor starter: 54 IN.
 - f. Pushbutton motor control station: 48 IN.

3.3 CABLE INSTALLATION

- A. General. Except as otherwise specified or indicated on the drawings, cable shall be installed according to the following procedures, taking care to protect the cable and to avoid kinking the conductors, cutting or puncturing the jacket, contamination by oil or grease, or any other damage.
1. Stranded conductor cable shall be terminated by lugs or pressure type connectors. Wrapping stranded cables around screw type terminals is not acceptable.
 2. Stranded conductor cable shall be spliced by crimp type connectors. Twist-on wire connectors may be used for splicing solid cable and for terminations at lighting fixtures.
 3. Splices shall be made only at readily accessible locations.
 4. Cable terminations and splices shall be made as recommended by the cable manufacturer for the particular cable and service conditions. All shielded cable stress cone terminations shall be IEEE Class 1 molded rubber type. Shielded cable splices shall be tape or molded rubber type as required. Shielded cable splices and stress cone terminations shall be made by qualified splicers. Materials shall be by 3M Company, Plymouth/Bishop, Raychem Electric Power Products, or approved equal.

5. Cable shall not be pulled tight against bushings nor pressed heavily against enclosures.
 6. Cable-pulling lubricant shall be compatible with all cable jackets; shall not contain wax, grease, or silicone; and shall be Polywater "Type J".
 7. Spare cable ends shall be taped, coiled, and identified.
 8. Cables shall not be bent to a radius less than the minimum recommended by the manufacturer.
 9. All cables in one conduit, over 1 foot long, or with any bends, shall be pulled in or out simultaneously.
 10. Circuits shall not be combined to reduce conduit requirements unless acceptable to Engineer.
- B. Underground Cable Pulling Procedure. Care shall be taken to prevent excessive physical stresses that would cause mechanical damage to cables during pulling.

3.4 CONDUIT INSTALLATION.

- A. Contractor shall be responsible for routing all conduits. This shall include all conduits indicated on the one-lines, riser diagrams, and home-runs shown on the plan drawings. Conduits shall be routed as defined in these specifications. Where conduit routing is shown on plans, it shall be considered a general guideline and shall be field verified to avoid interferences.
- B. Except as otherwise specified or indicated on the drawings, conduit installation and identification shall be completed according to the following procedures.
- C. Installation of Interior and Exposed Exterior Conduit. This section covers the installation of conduit inside structures, above and below grade, and in exposed outdoor locations. In general, conduit inside structures shall be concealed. Large conduit and conduit stubs may be exposed unless otherwise specified or indicated on the drawings. No conduit shall be exposed in water chambers unless so indicated on the drawings.
- D. Unless otherwise indicated on the drawings, Contractor shall be responsible for routing the conduit to meet the following installation requirements:
1. Conduit installed in all exposed indoor locations, except corrosive areas indicated on the drawings, and in floor slabs, walls, and ceilings of hazardous (classified) locations, shall be intermediate metal. Exposed conduit shall be rigidly supported by hot-dip galvanized hardware and framing materials, including nuts and bolts.
 2. Conduit installed in floor slabs and walls in non-hazardous locations shall be rigid Schedule 80 PVC.

3. Conduit installed in all exposed outdoor locations shall be PVC-coated rigid steel, rigidly supported by PVC-coated framing materials. Mounting hardware, which includes nuts, bolts, and anchors, shall be stainless steel. All damaged coatings shall be repaired according to the manufacturer's instructions.
4. Final connections to dry type transformers, to motors without flexible cords, and to other equipment with rotating or moving parts shall be liquidtight flexible metal conduit with watertight connectors installed without sharp bends and in the minimum lengths required for the application, but not longer than 6 feet unless otherwise acceptable to Engineer.
5. Terminations and connections of rigid steel and intermediate metal conduit shall be taper threaded. Conduits shall be reamed free of burrs and shall be terminated with conduit bushings.
6. Exposed conduit shall be installed either parallel or perpendicular to structural members and surfaces.
7. Two or more conduits in the same general routing shall be parallel, with symmetrical bends.
8. Rigid Schedule 80 PVC conduit shall have supports and provisions for expansion as required by NEC Article 352.
9. Metallic conduit connections to sheet metal enclosures shall be securely fastened by locknuts inside and outside.
10. Rigid Schedule 80 PVC conduit shall be secured to sheet metal device boxes using a male terminal adapter with a locknut inside or by using a box adapter inserted through the knockout and cemented into a coupling.
11. Conduits in walls or slabs, which have reinforcement in both faces, shall be installed between the reinforcing steel. In slabs with only a single layer of reinforcing steel, conduits shall be placed under the reinforcement. Conduits larger than 1/3 of the slab thickness shall be concrete encased under the slab.
12. Conduits that cross structural joints where structural movement is allowed shall be fitted with concretetight and watertight expansion/deflection couplings, suitable for use with metallic conduits and rigid Schedule 40 PVC conduits. The couplings shall be Appleton Type DF, Crouse-Hinds Type XD, O-Z Type DX, or approved equal.
13. Conduit shall be clear of structural openings and indicated future openings.
14. Conduits shall be capped during construction to prevent entrance of dirt, trash, and water.

15. Exposed conduit stubs for future use shall be terminated with galvanized pipe caps.
 16. Concealed conduit for future use shall be terminated in equipment or fitted with couplings plugged flush with structural surfaces.
 17. Where the drawings indicate future duplication of equipment wired hereunder, concealed portions of conduits for future equipment shall be provided.
 18. Conduit shall not be routed across the surface of a floor or walkway unless approved by PWC.
 19. PVC-coated rigid steel conduit shall be threaded and installed as recommended by the conduit manufacturer's installation procedure using appropriate tools.
 20. All conduits that enter enclosures shall be terminated with acceptable fittings that will not affect the NEMA rating of the enclosure.
 21. Nonmetallic conduit, which turns out of concrete slabs or walls, shall be connected to a 90 degree elbow of PVC-coated rigid steel conduit before it emerges.
 22. Power conductors to and from adjustable frequency drives shall be installed in steel conduit.
- E. Underground Conduit Installation. All excavation, backfilling, and concrete work shall conform to the respective sections of these specifications. Underground conduit shall conform to the following requirements:
1. All underground conduits shall be concrete encased as indicated on drawings, within 15 feet of building entrances and under and within 5 feet of roadways.
 2. Concrete encased conduit shall be Schedule 40 PVC. Conduits shall have end bells where terminated at walls. All joints shall be solvent welded in accordance with the recommendations of the manufacturer.
 3. Underground conduits indicated not to be concrete encased shall be rigid Schedule 80 PVC.
 4. Underground conduit bend radius shall be at least 2 feet at vertical risers and at least 3 feet elsewhere.
 5. Underground conduits and conduit banks shall have at least 2 feet of earth cover, except where indicated otherwise.

6. Underground nonmetallic conduits, which turn out of concrete or earth in outdoor locations, shall be connected to 90 degree elbows of PVC-coated rigid steel conduit before they emerge.
 7. Conduits not encased in concrete and passing through walls, which have one side in contact with earth, shall be sealed watertight with special rubber-gasketed sleeve and joint assemblies or with sleeves and modular rubber sealing elements.
 8. Underground conduits shall be sloped to drain to handholes / manholes.
 9. Instrument cables shall be separated the maximum possible distance from all power wiring in pull-boxes, manholes, and handholes.
- F. Sealing of Conduits. After cable has been installed and connected, conduit ends shall be sealed by forcing nonhardening sealing compound into the conduits to a depth at least equal to the conduit diameter. This method shall be used for sealing all conduits at handholes, manholes, electrical enclosures with connecting conduit routed below grade, and for 1 inch and larger conduit connections to equipment.
1. Conduits entering hazardous (classified) areas and submersible or explosion proof enclosures shall have Appleton "Type ESU" or Crouse-Hinds "EYS" sealing fittings with sealing compound.
- G. Reuse of Existing Conduits. Existing conduits may be reused subject to the concurrence of Engineer and compliance with the following requirements:
1. A wire brush shall be pulled through the conduit to remove any loose debris.
 2. A mandrel shall be pulled through the conduit to remove sharp edges and burrs.

3.5 GROUNDING AND BONDING

- A. Ground Rods: Ground rods shall be rolled to a commercially round shape from a welded copper clad steel manufactured by the molten welding process or by the electro formed process (molecularly bonded). They shall have an ultimate tensile strength of 75,000 pounds per square inch (psi) and an elastic limit of 49,000 psi. The rods shall be not less than 3/4 inch in diameter by 10 feet in length; and the proportion of copper shall be uniform throughout the length of the rod. The copper shall have a minimum wall thickness of 0.013 inch at any point on the rod.
- B. Fittings: Grounding connections to equipment shall be bolted. Cable end connections may be made by use of the crucible weld process or bolted type connectors. Bolted type connectors for this application shall consist of corrosion resistant copper alloy with silicone bronze bolts, nuts and lockwashers which are designed for this purpose.
- C. Grounding Conductors: A green, insulated equipment grounding conductor, which shall be separate from the electrical system neutral conductor, shall be furnished and installed for all

circuits. Equipment grounding conductors shall be furnished and installed in all conduits. Use of conduits as the NEC required equipment grounding conductor is not acceptable. Where specified or shown a copper strap shall be furnished and installed as the grounding conductor.

- D. The maximum resistance to ground of a driven ground rod shall not exceed 10 ohms under normally dry conditions. Where the resistance obtained with one (1) ground rod exceeds 10 ohms, additional ground rods shall be installed not less than 10 feet on centers. Except where specifically indicated otherwise, all exposed non current carrying metallic parts of electrical equipment, metallic raceway systems, grounding conductors in nonmetallic raceways and neutral conductors of wiring systems shall be grounded.
- E. The ground connection shall be made at the main service equipment and shall be extended to the point of entrance of the metallic water service. Connection to the water pipe shall be made by a suitable ground clamp or lug connection to a plugged tee. If flanged pipes are encountered, connection shall be made with the lug bolted to the street side of the flanged connection. If there is not suitable metallic water service to the facility, the ground connection shall be made to the driven ground rods on the exterior of the building.
- F. Where ground fault protection is employed, care shall be taken so that the connection of the ground and neutral does not interfere with the correct operation of the ground fault protection system.
 - G. Equipment grounds shall be solid and continuous from a connection at earth to all distribution panelboards. Ground connections at panelboards, outlets, equipment, and apparatus shall be made in an approved and permanent manner.
 - H. Metal surfaces where grounding connections are to be made shall be clean and dry. Steel surfaces shall be ground or filed to remove all scale, rust, grease, and dirt. Copper and galvanized steel shall be cleaned with emery cloth to remove oxide before making connections.
 - I. A main ground grid shall be provided for each structure and interconnecting structure grids consisting of driven ground rods. The ground rods shall be driven deep enough to obtain a ground resistance of not more than 10 ohms and shall be interconnected by the use of copper cable bus (3" strap minimum), or a bare copper conductor sized to the largest service entrance ground, welded to the rods by the crucible weld process. The grounding cables shall be installed after the excavations for the building have been completed and prior to the pouring of concrete for the footings, mats, etc. Copper "pigtailed" shall be connected to the ground system and shall enter the buildings and structure from the outside and shall be connected to steel structures, and equipment as described in this Section and as required to provide a complete grounding system.
 - J. Grounding conductors shall be continuous between points of connection; splices shall not be permitted. Where conductors are exposed and subject to damage from personnel, traffic, etc., conductors shall be installed in metal raceway. The raceway shall be bonded to the grounding system. Connections to ground rods shall be exposed to permit maintenance and inspection for continuity and effectiveness of grounding system. Where subsurface conditions do not permit use of driven ground

rods to obtain proper ground resistance, rods shall be installed in a trench or plate electrodes shall be provided, as applicable and necessary to obtain proper values of resistance.

- K. Conduit which enters equipment such as motor controls, instrument and control panels, and similar equipment shall be bonded to the ground bus, where provided, and as otherwise required by the NEC.

3.6 IDENTIFICATION.

- A. Cable. Except for lighting and receptacle circuits, each individual wire in power, control, indication, and instrumentation circuits shall be provided with identification markers at the point of termination. The wire markers shall be of the heat-shrinkable tube type, with custom typed identification numbers. The wire numbers shall be as indicated on the equipment manufacturer's drawings. The wire markers shall be positioned to be readily visible for inspection. Power wires shall be color coded with electrical tape or colored wire jacket; white-N, black, and red for 120/240 volt, 3-wire; and gray-N, brown, orange and yellow for 480/277 volt, 4-wire circuits.
- B. Pump Control Panels. Panels shall be provided with nameplates identifying the related equipment. Pilot controls and indicating lights shall have engraved or etched legends ("start", "stop", etc.) as indicated on the drawings. Nameplates shall be laminated black-over-white plastic, with 1/8 inch engraved letters, and shall be securely fastened with stainless steel screws to the motor starters.
- C. Circuit Breakers. Circuit breakers shall be provided with nameplates identifying related equipment. Nameplates shall be laminated black-over-white plastic, with 1/8 inch engraved letters, and shall be securely fastened with stainless steel screws to the circuit breakers.
- D. Disconnect Switches. All switches shall have front cover-mounted permanent nameplates that include switch type, manufacturer's name and catalog number, and horsepower [kW] rating. An additional nameplate, engraved or etched, laminated black-over-white plastic, with 1/8 inch letters, shall be provided to identify the associated equipment. Both nameplates shall be securely fastened with stainless steel screws to the enclosure.
- E. Arc Flash Hazard Labels. Lighting panels, power panels, power centers, and meter socket enclosures shall be provided with permanent labels warning the risk of arc flash and shock hazard. Labels shall be designed in accordance with ANSI Z535.4-1998, NFPA 70E, and shall include the following:

WARNING
Arc Flash and Shock Hazard

Appropriate personal protection equipment (PPE) required. SEE NFPA 70E. Equipment must be accessed by qualified personnel only. Turn off all power sources prior to working on or inside equipment.

3.7 FIELD QUALITY CONTROL

- A. Equipment furnished under this Contract for use on future work and all concealed equipment, including conduits, shall be dimensioned, on the record drawings, from visible and permanent building features.
- B. After installation, all equipment shall be tested as recommended by the manufacturer.
- C. Verify all components are operational.
- D. Perform ground-fault performance testing as required by NEC Article 230-95(c).
- E. Test Equipment Interface:
 - 1. Verify systems coordination and operation.
- F. Set all adjustable trip protective devices as required for system protection and coordination.
- G. Verify all system and equipment ground continuity.
- H. Adjust installed equipment for proper operation of all electrical and mechanical components.
- I. Replace equipment and systems found inoperative or defective and re-test.
 - 1. If equipment or system fails re-test, replace it with products that conform to Contract Documents.
 - 2. Continue remedial measures and re-tests until satisfactory results are obtained.
 - 3. Remedial measures and re-tests will be done at no cost to the PWC.
- J. Tests shall be performed in the presence of the Engineer.
 - 1. Tests shall be scheduled with the Engineer and Owner, a minimum of two (2) weeks in advance.
 - 2. Required certificates of testing or review shall be presented to the Engineer upon completion of the tests.
- K. At Completion of Installation:
 - 1. Test to ensure all equipment is free of short circuits and improper grounds.
 - 2. Test to ensure all equipment is operational.

3.8 CLEANING

- A. Clean dirt and debris from all surfaces.

- B. Apply touch-up paint as required to repair scratches, etc.
- C. Replace nameplates damaged during installation.
- D. Thoroughly vacuum the interior of all enclosures to remove dirt and debris.

3.9 DEMONSTRATION

- A. Demonstrate equipment in accordance with Contract and Bidding Requirements.
- B. PWC to provide a final inspection and approval to ensure equipment, quality of workmanship, and installation are in accordance with PWC's published design standards.

*** END OF SECTION ***

APPENDICES

LS#11 Neal St

LS#11 Neal St



1/30/2024, 11:37:49 AM

- | | | | | | |
|---|--|--|---|---|--|
| <ul style="list-style-type: none"> ➔ Sludge Sewer Main ➔ Sewer Force Main ➔ Force Mains ➔ Abandoned Mains ➔ Sewer Gravity Main Abandoned ➔ Sewer Gravity Main ➔ Gravity Main Collector | <ul style="list-style-type: none"> ➔ Gravity Main Outfall ➔ Gravity Main Interceptor ➔ Gravity Main Private Sewer Network Structure LS Lift Station PS Sludge Pump Station | <ul style="list-style-type: none"> ● Sewer Fitting ⊗ Sewer System Valve ⊗ Sewer Control Valve ● Control Vale ● Air Release Valve ● Cutoff Valve ● Check Valve | <ul style="list-style-type: none"> — Sewer Lateral — Sewer Lateral Private — Sewer Lateral Abandoned Sewer Clean Out ● Clean Out | <ul style="list-style-type: none"> ● Clean Out Abandoned ● Sewer Manhole ● Manhole ● Manhole Private ● Manhole Abandoned Street Names | <ul style="list-style-type: none"> ▭ Cumberland County Parcel ○ Site Address ✓ Septic Incidents |
|---|--|--|---|---|--|

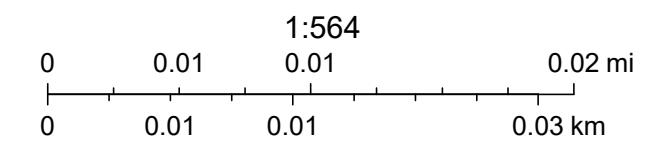

NC CGIA, Maxar, Microsoft

LS#11 Neal St Force Main



1/30/2024, 11:33:57 AM

- | | | |
|---|---|--|
| <ul style="list-style-type: none"> — Sludge Sewer Main — Sewer Force Main — Force Mains — Abandoned Mains — Sewer Gravity Main Abandoned — Sewer Gravity Main — Gravity Main Collector — Gravity Main Outfall — Gravity Main Interceptor | <ul style="list-style-type: none"> — Gravity Main Private — Sewer Network Structure — Lift Station — Sludge Pump Station — Sewer Control Valve — Control Vale — Air Release Valve — Cutoff Valve — Check Valve | <ul style="list-style-type: none"> ⊗ Sewer System Valve ⊙ Sewer Manhole ● Manhole ● Manhole Private ● Manhole Abandoned Street Names ▭ Cumberland County Parcel ✓ Septic Incidents |
|---|---|--|

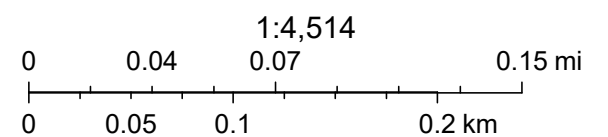

Sources: Esri, Airbus DS, USGS, NGA, NASA, CGIAR, N Robinson, NCEAS, NLS, OS, NMA, Geodastystyrelsen, Rijkswaterstaat, GSA, Geoland, FEMA, Intermap and the GIS user community

PUMP DATA

- CAPACITY 400 G.P.M. EACH
 TOTAL DYNAMIC HEAD 49 ft.
 TOTAL DYNAMIC SUCTION LIFT 17 ft.
 MAX. PRIMING LIFT 21
 PUMP SHALL BE 8" x 4" MODEL T4A-B GORMAN RUPP OR EQUAL (2 REQUIRED)
 BELT DRIVEN
 ELECTRIC MOTORS:
 SHALL BE HORIZONTAL, OPEN DRIP
 PROOF TYPE OF 15HP, 1550 R.P.M. 3 Ø 60 HERTZ 240V
- THE FLOAT TO BE SET SO THAT THE PUMPS WILL COME ON WHEN THE WATER REACHES ELEV. 65.30 AND CUTS OFF WHEN THE LEVEL DROPS TO ELEV. 63.30 BASED ON AVERAGE INFLOW OF 130 G.P.M. HOWEVER FLOATS WILL BE ADJUSTED IN THE FIELD ACCORDING TO ACTUAL FLOW SO THAT DETENTION TIME WILL NOT EXCEED 30 MIN.

NOTES

- LIGHT TO BE DETERMINED IN FIELD BY ENGINEERS.
- POWER SUPPLY BY DEVELOPER MOBILE POWER SUPPLY AS A SECONDARY SOURCE BY P.W.C.
- HOUSE TO BE VENTED.
- SWITCH ALTERNATOR TO BE PROVIDED SO THAT PUMPS WILL ALTERNATE AND IF ONE PUMP CANNOT CARRY THE LOAD, THEN THE OTHER PUMP WILL COME ON.
- AUDIO VISUAL ALARM SYSTEM TO BE PROVIDED, THE LOCATION AND DESIGN TO BE DETERMINED BY THE ENGINEER. THE HIGH WATER ALARM WILL BE ACTIVATED AT ELEV. 67.50
- A PROPERLY TRAPPED DRAIN TO WET WELL WILL BE PLACED IN DRY WELL.
- THE LOWER 3'-0" SECTION OF WET WELL SHALL BE BUILT MONOLITHICALLY WITH BASE SLAB.
- LIFT STATION WILL BE MONITORED BY PWC TRAINED PUMPING MAINTENANCE CREW ON DAILY BASIS.

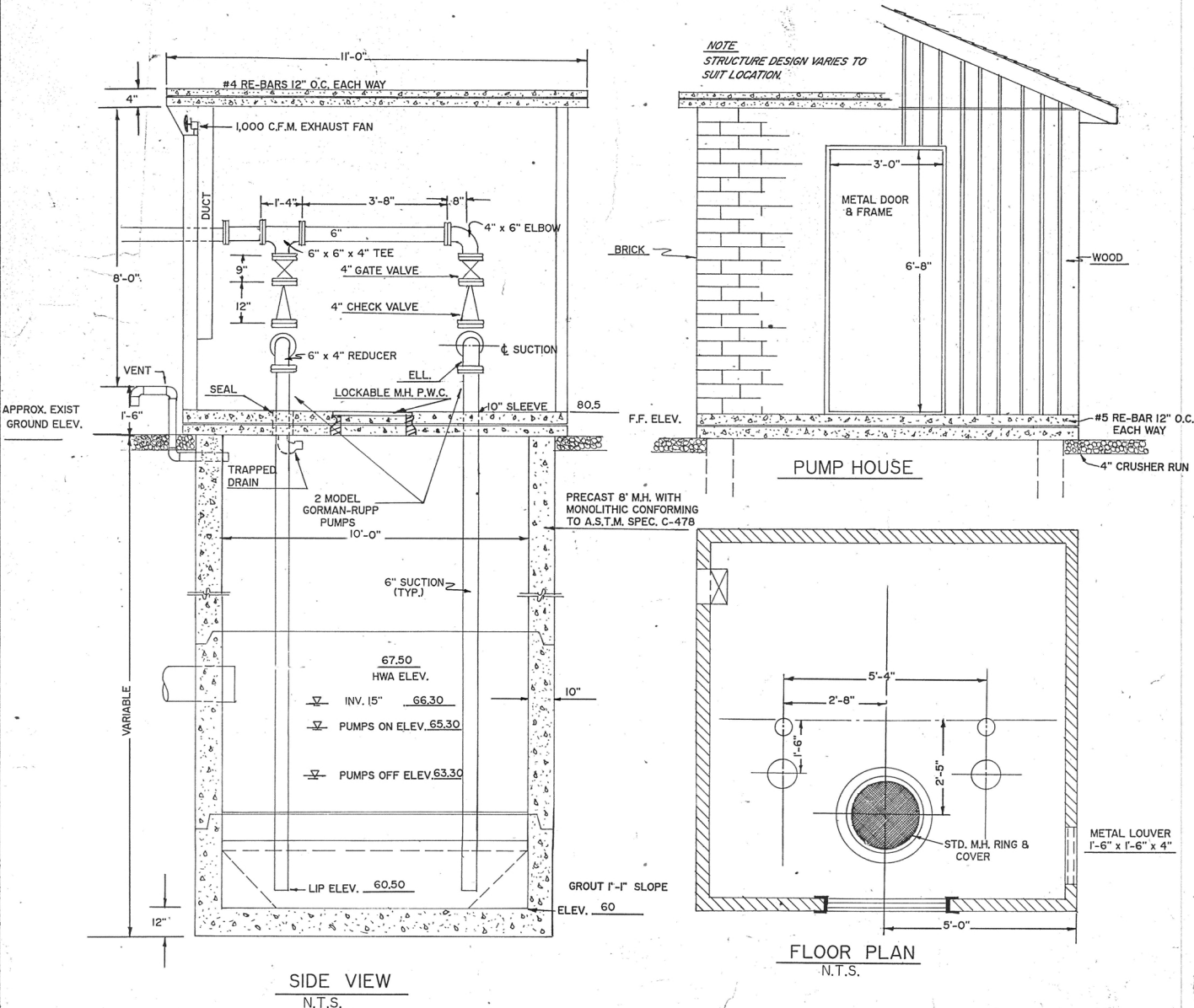

SYM	DESCRIPTION	BY
REVISIONS		
PWC PUBLIC WORKS COMMISSION OF THE CITY OF FAYETTEVILLE		
UPGRADE OF NEAL ST.		
LIFT STATION		
DESIGNED AND CHECKED	H. MALY	DATE 10-19-94
APPROVED BY	[Signature]	SCALE N.T.S.
CS - 10339		of 1

LS#17 Orange St

LS#17 Orange St



1/30/2024, 1:52:59 PM

- | | | | | | |
|--|---|--|---|---|---|
| <ul style="list-style-type: none"> Sludge Sewer Main Gravity Main Outfall Force Mains Abandoned Mains Sewer Gravity Main Abandoned Sewer Gravity Main Gravity Main Collector | <ul style="list-style-type: none"> Gravity Main Interceptor Gravity Main Private Lift Station Sludge Pump Station | <ul style="list-style-type: none"> Sewer Fitting Sewer Control Valve Control Vale Air Release Valve Cutoff Valve Check Valve | <ul style="list-style-type: none"> Sewer System Valve Sewer Lateral Sewer Lateral Private Sewer Lateral Abandoned Sewer Clean Out Clean Out | <ul style="list-style-type: none"> Clean Out Abandoned Sewer Manhole Manhole Private Manhole Abandoned Street Names | <ul style="list-style-type: none"> Cumberland County Parcel Site Address Septic Incidents |
|--|---|--|---|---|---|

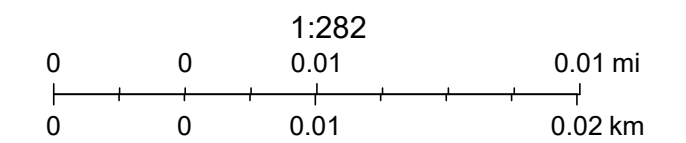

NC CGIA, Maxar, Microsoft

LS#17 Orange St

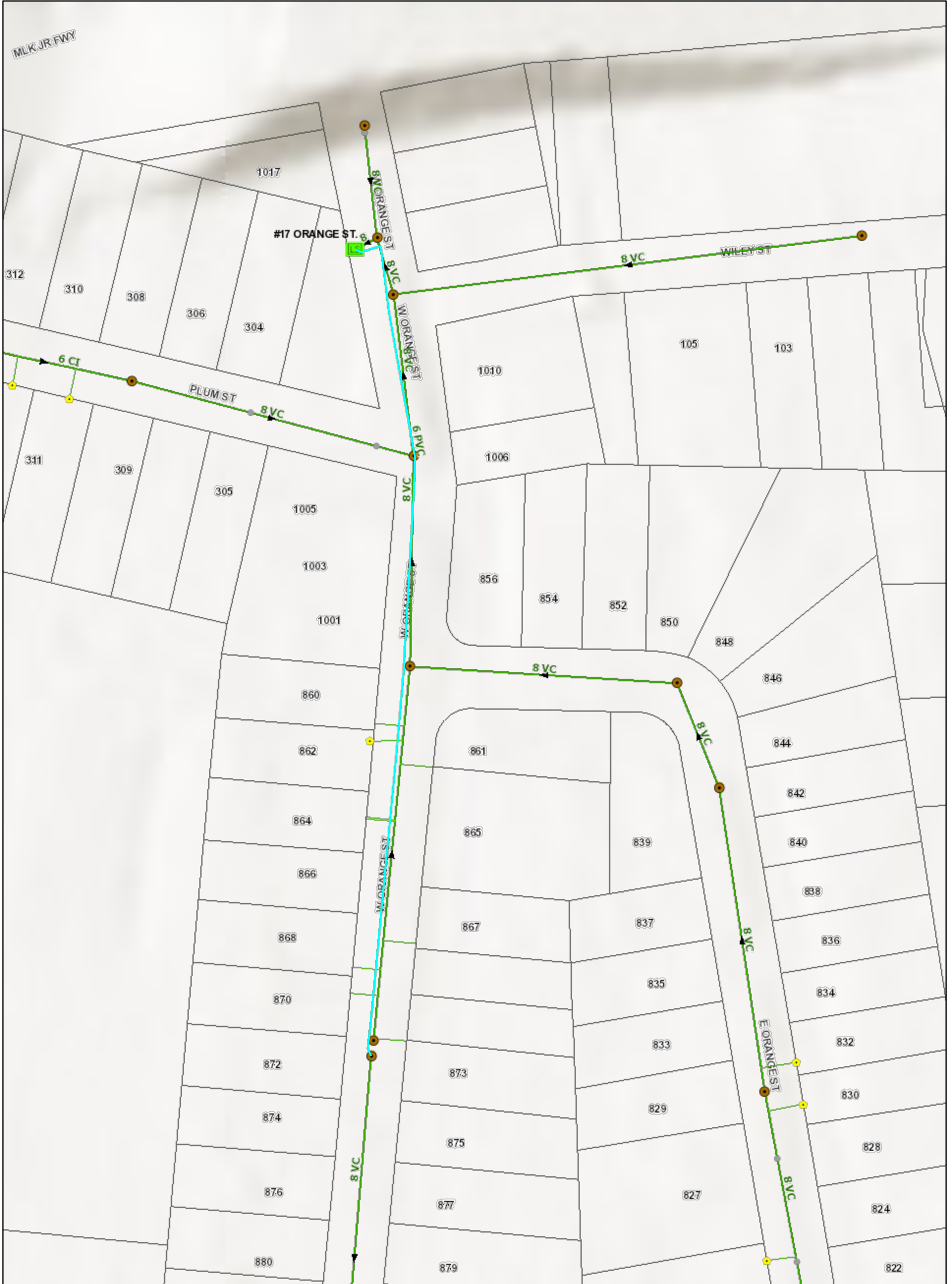

1/30/2024, 1:49:26 PM

- | | | | |
|---|--|--|---|
| <ul style="list-style-type: none"> — Sludge Sewer Main — Sewer Force Main — Force Mains - - - Abandoned Mains - - - Sewer Gravity Main Abandoned — Sewer Gravity Main — Gravity Main Collector — Gravity Main Outfall — Gravity Main Interceptor | <ul style="list-style-type: none"> — Gravity Main Private — Sewer Network Structure — Lift Station PS Sludge Pump Station • Sewer Fitting — Sewer Control Valve • Control Vale • Air Release Valve • Cutoff Valve | <ul style="list-style-type: none"> ○ Check Valve ⊗ Sewer System Valve — Sewer Lateral — Sewer Lateral — Sewer Lateral Private - - - Sewer Lateral Abandoned — Sewer Clean Out • Clean Out • Clean Out Abandoned | <ul style="list-style-type: none"> • Sewer Manhole • Manhole Private • Manhole Abandoned — Street Names □ Cumberland County Parcel ○ Site Address ✓ Septic Incidents |
|---|--|--|---|

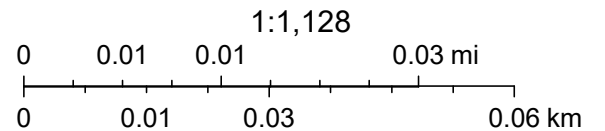

Sources: Esri, Airbus DS, USGS, NGA, NASA, CGIAR, N Robinson, NCEAS, NLS, OS, NMA, Geodatastyrelsen, Rijkswaterstaat, GSA, Geoland, FEMA, Intermap and the GIS user community

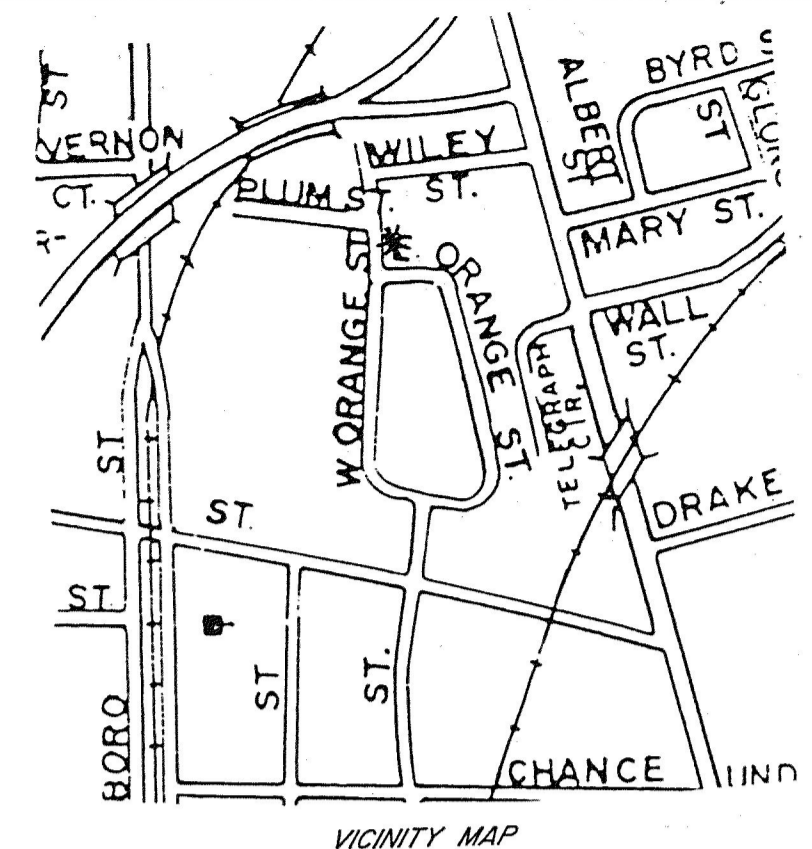

NOTES

1. LIGHT TO BE DETERMINED IN THE FIELD BY ENGINEERS.
2. POWER SUPPLY BY P.W.C. MOBILE POWER SUPPLY AS A SECONDARY SOURCE BY P.W.C.
3. HOUSE TO BE VENTED.
4. SWITCH ALTERNATOR TO BE PROVIDED SO THAT PUMPS WILL ALTERNATE AND IF ONE CANNOT CARRY THE LOAD, THEN THE OTHER PUMP WILL COME ON.
5. AUDIO VISUAL ALARM SYSTEM TO BE PROVIDED, THE LOCATION AND DESIGN TO BE DETERMINED BY THE ENGINEER. THE HIGH WATER ALARM WILL BE ACTIVATED AT ELEV. 89.59
6. A PROPERLY TRAPPED DRAIN TO WET WELL WILL BE PLACED IN DRY WELL.
7. THE LOWER 3'-8" SECTION OF THE WET WELL SHALL BE BUILT MONOLITHICALLY WITH BASE SLAB.
8. LIFT STATION WILL BE MONITORED BY P.W.C. TRAINED PUMPING MAINTENANCE CREW ON DAILY BASIS.

PUMP DATA

1. CAPACITY 200 G.P.M.
TOTAL DYNAMIC HEAD 28 FT.
TOTAL DYNAMIC SUCTION LIFT 14.14 FT.
MAX. PRIMING LIFT 16 FT.
PUMP SHALL BE 3"x3" MODEL T3A-B GORMAN RUPP OR EQUAL (2 REQUIRED)
BELT DRIVEN
ELECTRIC MOTORS SHALL BE HORIZONTAL, OPEN DRIP PROOF TYPE OF 5HP, 1150 R.P.M. 3 Ø 60 HERTZ 240V
2. THE FLOAT TO BE SET SO THAT THE PUMPS WILL COME ON WHEN THE WATER REACHES ELEV. 88.92 AND CUTS OFF WHEN THE LEVEL DROPS TO ELEV. 87.92 BASED ON AVERAGE INFLOW OF 15 G.P.M. HOWEVER FLOATS WILL BE ADJUSTED IN THE FIELD ACCORDING TO ACTUAL FLOW SO THAT DETENTION TIME WILL NOT EXCEED 30 MIN.

NOTE

STRUCTURE DESIGN VARIES TO SUIT LOCATION.

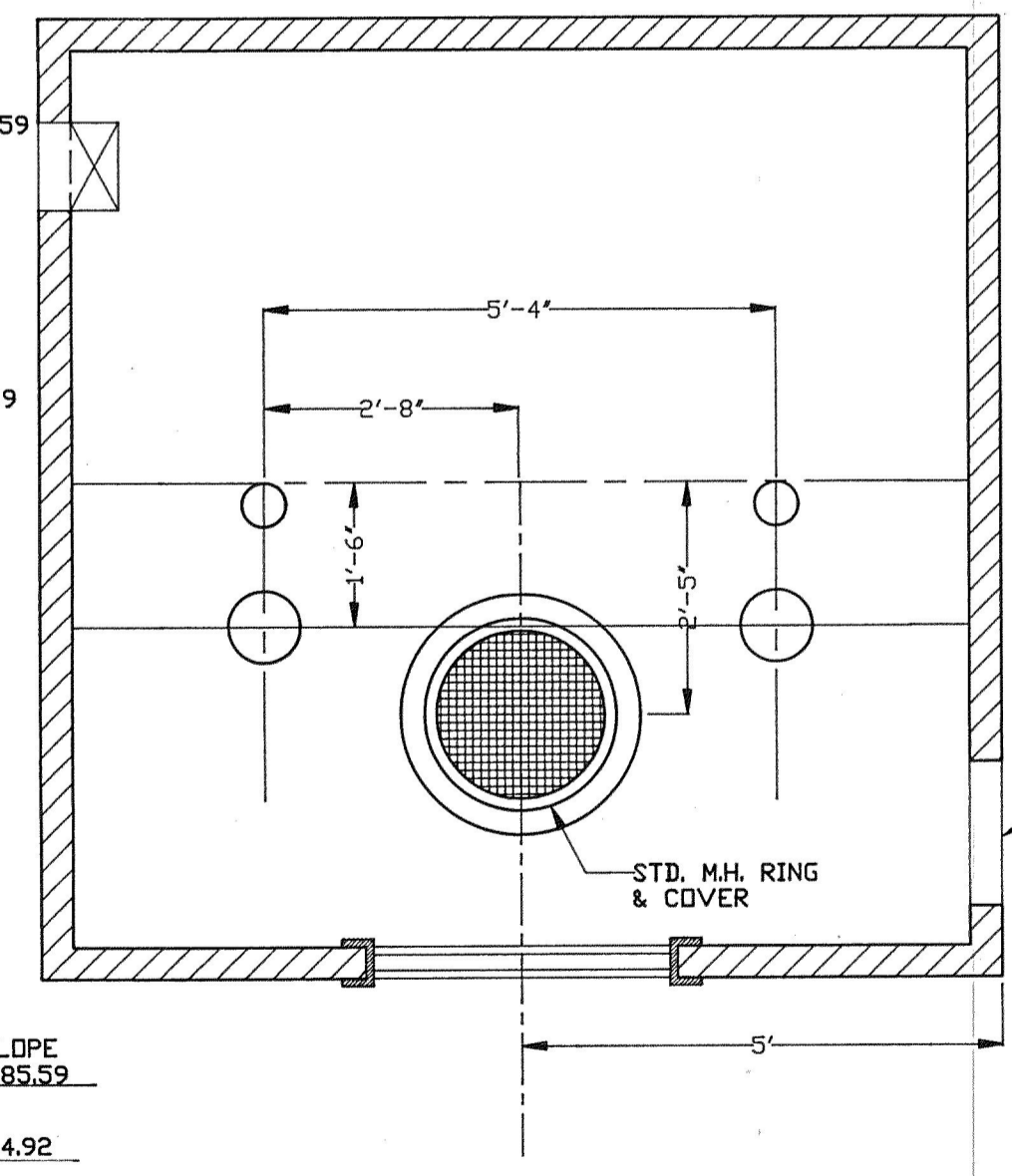
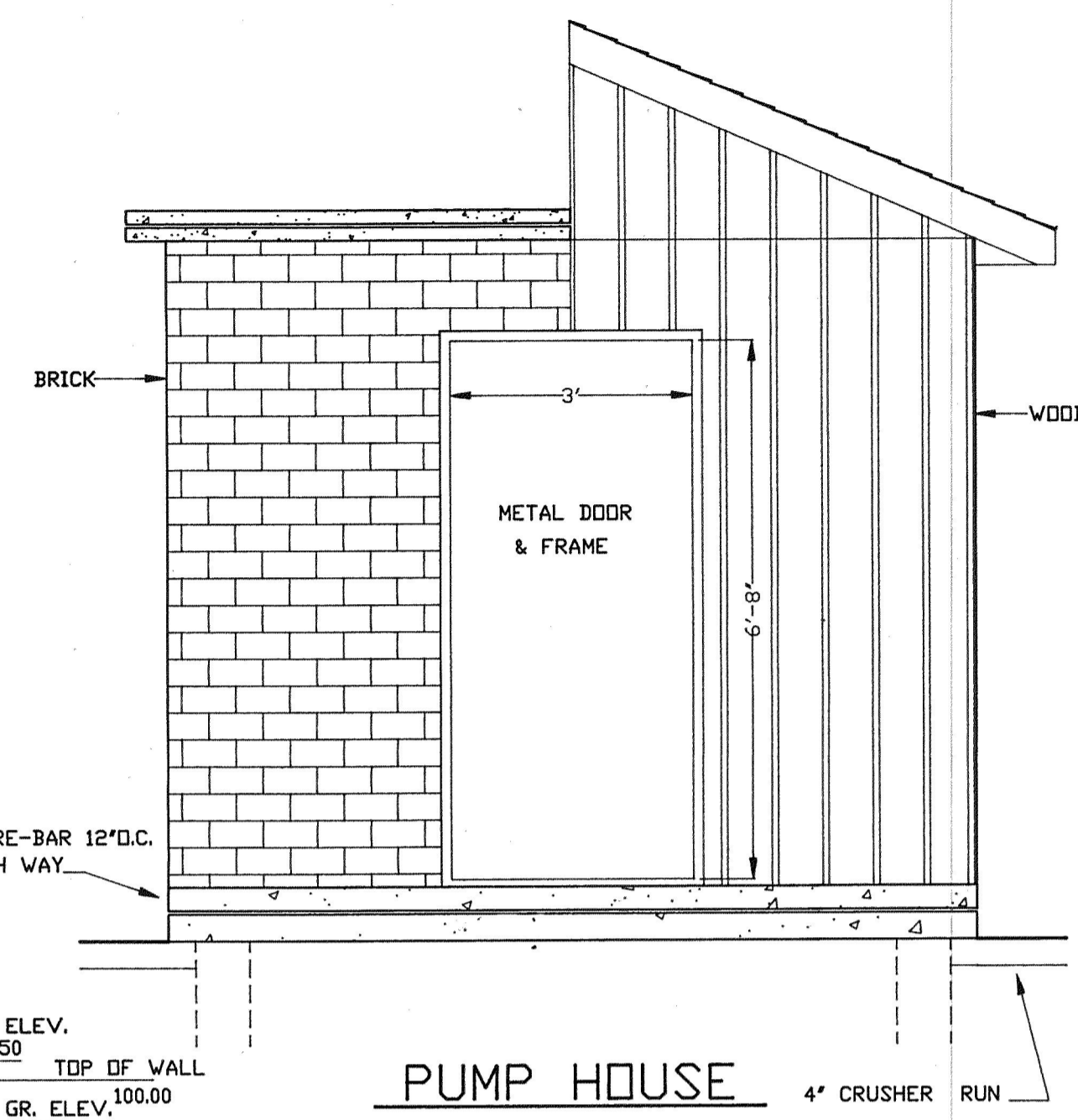
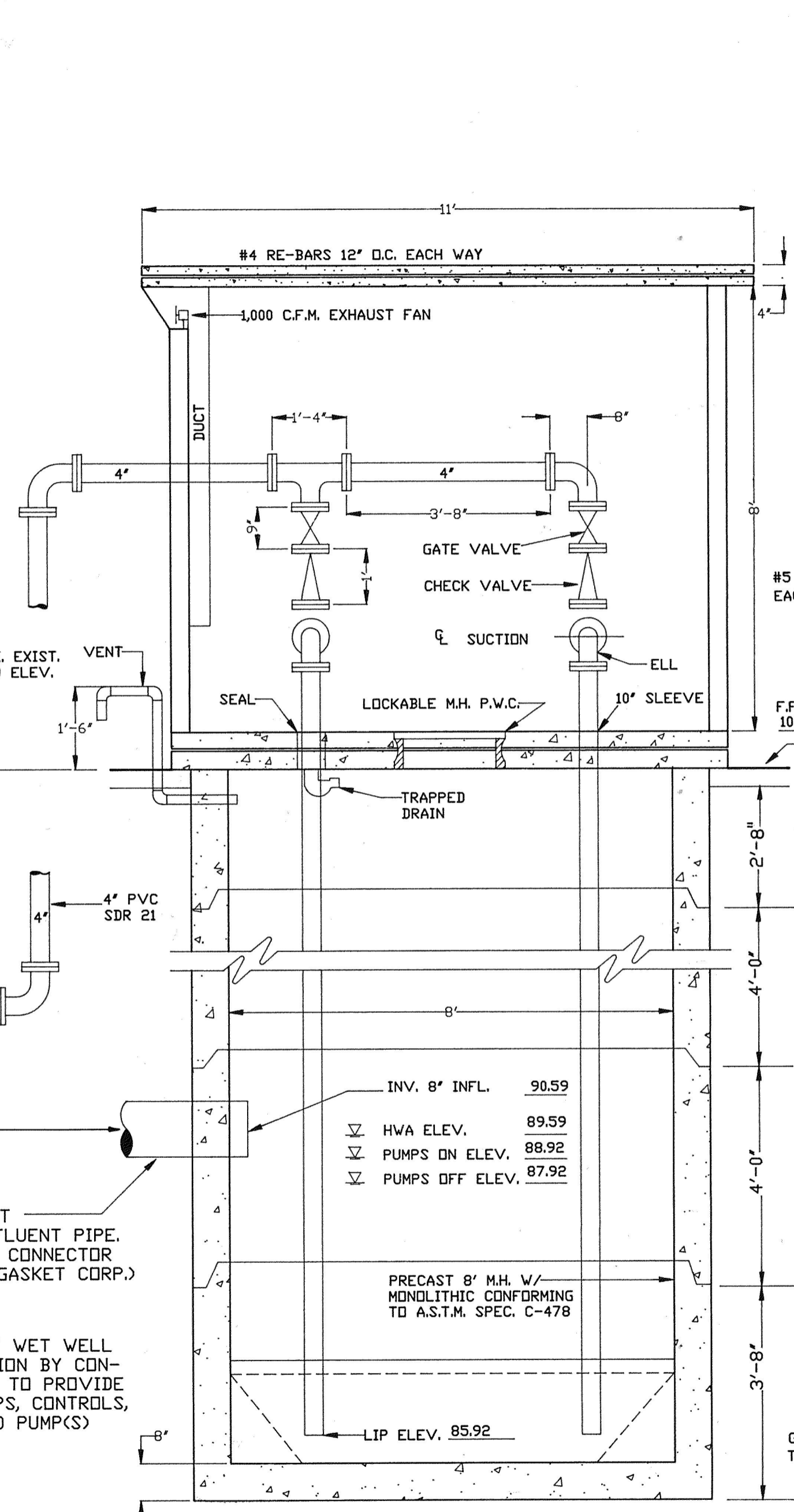

SIDE VIEW

FLOOR PLAN

(8" Ø) PRECAST HOLE FOR 8" INFLUENT PIPE. FLEXIBLE BOOT CONNECTOR (PRESS SEAL GASKET CORP.) ASTM C923

NOTE: EXCAVATION OF WET WELL AND INSTALLATION BY CONTRACTOR, P.W.C. TO PROVIDE TOP SLAB, PUMPS, CONTROLS, AND PIPING AND PUMP(S) HOUSING.

CAD FILE ORGELIFT		
SYM	DESCRIPTION	BY
REVISIONS		
PWC PUBLIC WORKS COMMISSION OF THE CITY OF FAYETTEVILLE		
ORANGE STREET		
LIFT STATION		
DRAWN BY	W.R.C.	DATE 8-23-95
CHECKED BY	<i>[Signature]</i>	SCALE N.T.S.
APPROVED BY	<i>[Signature]</i>	CS-10660

8-31-95

LS#51 Rivercliff #2

PWC Utility Web Map



2/23/2024, 7:59:49 AM

- | | | | | | |
|------------------------------|--------------------------|---------------------|-------------------------|---------------------|--------------------------|
| Sludge Sewer Main | Gravity Main Outfall | Sewer Fitting | Sewer System Valve | Clean Out Abandoned | Cumberland County Parcel |
| Sewer Force Main | Gravity Main Interceptor | Sewer Control Valve | Sewer Lateral | Sewer Manhole | Site Address |
| Force Mains | Gravity Main Private | Control Vale | Sewer Lateral Private | Manhole Private | Septic Incidents |
| Abandoned Mains | Sewer Network Structure | Air Release Valve | Sewer Lateral Abandoned | Manhole Abandoned | |
| Sewer Gravity Main Abandoned | Lift Station | Cutoff Valve | Sewer Clean Out | Street Names | |
| Sewer Gravity Main | Sludge Pump Station | Check Valve | | | |
| Gravity Main Collector | | | | | |

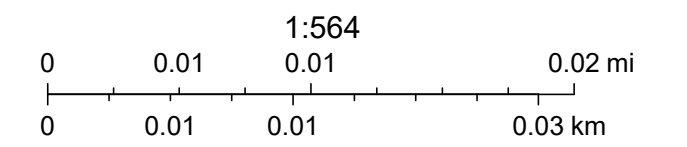

NC CGIA, Maxar, Microsoft

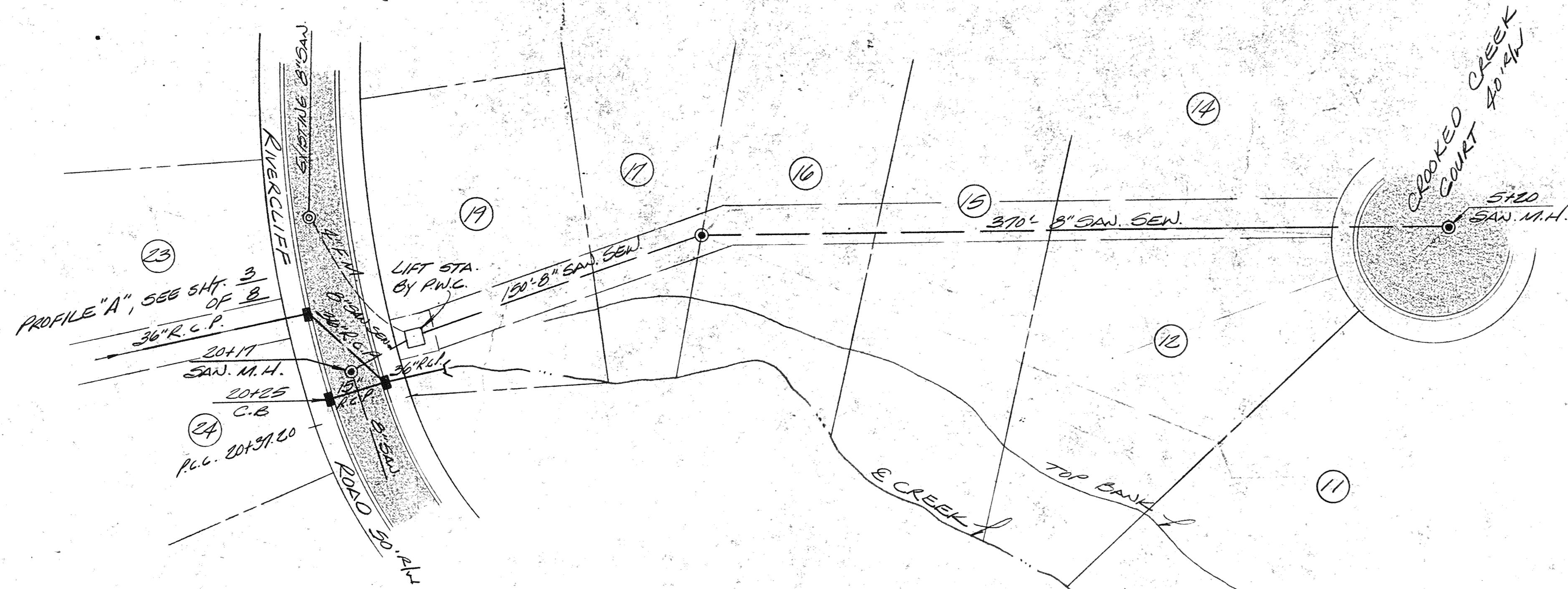

PROFILE "E"
(8" SAN. SEN. OUTFALL)

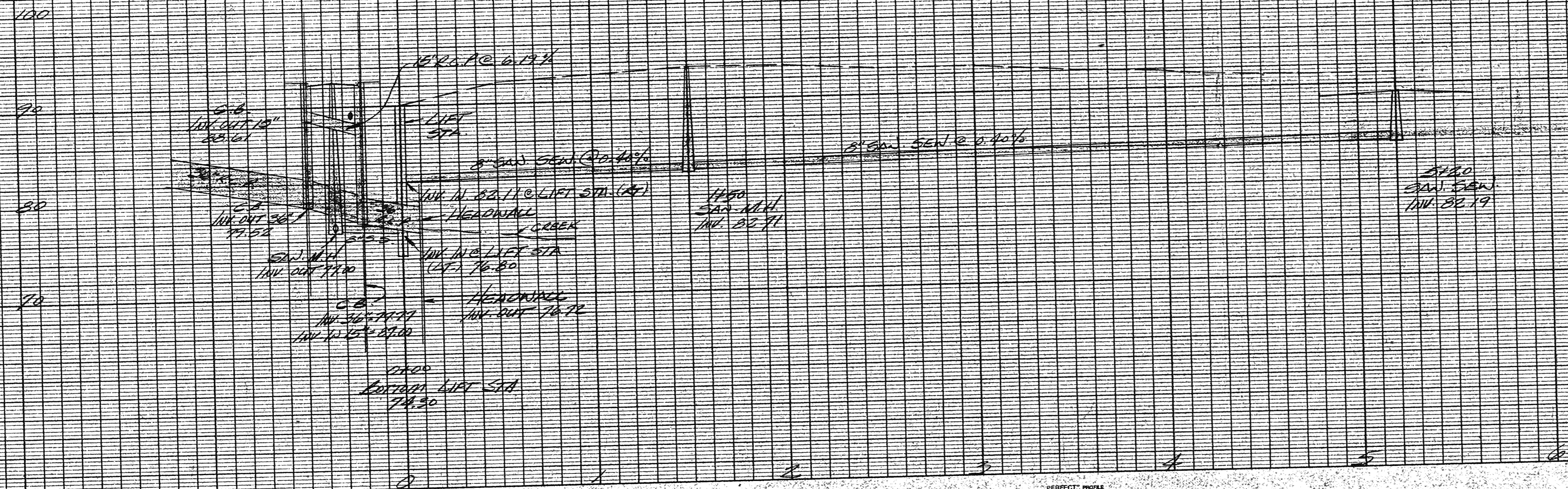

DATE	2-6-86	PROJECT	MOOREMAN & KIRBY, INC.	BOOK	100-514
SCALE	1" = 20'	DESCRIPTION	Engineers, Planners and Surveyors	SHEET	1 of 3
PROJECT	SAN. SEN.	LOCATION	188 BROADFORD RD. P. O. BOX 40774	DATE	1/85
			FAWCEVILLE, N.C. 28355	BY	JK
				CHECKED	JK
				DATE	1/86
				APPROVED	JK
				DATE	1/86

PERFECT
PLATE
METER

PROJECT TITLE _____ Pay App # _____

SALES/USE TAX CERTIFICATE

(Use as many sheets as needed/sign affidavit of last sheet per pay estimate)

Analysis of consumed material **Manufactured or Purchased** by you. Sales and/or Use Tax Regulation Number 41 requires that the City of Fayetteville secure from each contractor certified statements setting forth the cost of the materials and supplies manufactured or purchased by you and consumed in construction. This form is provided for you to list the materials consumed in construction. Please complete this form by inserting the information required below.

<u>Vendor Name</u>	<u>Date Purchased</u>	<u>Invoice Number</u>	<u>Amount Less Tax</u>	<u>Sales Tax % State/ % Local</u>	<u>Invoice Total</u>	<u>County Paid</u>
_____	_____	_____	_____	_____/_____	_____	_____
_____	_____	_____	_____	_____/_____	_____	_____
_____	_____	_____	_____	_____/_____	_____	_____
_____	_____	_____	_____	_____/_____	_____	_____
_____	_____	_____	_____	_____/_____	_____	_____
_____	_____	_____	_____	_____/_____	_____	_____

\$ _____ \$ _____ \$ _____ \$ _____

AFFIDAVIT

This is to certify that sales/use tax was or will be paid as stated above on materials and supplies purchased or manufactured by the **City of Fayetteville, North Carolina**, for the above mentioned project during the period and billed on this payment application # _____

(Contractor)

(Authorized Signature/Date)

(Address)

(Telephone Number)

(City, State, Zip)

(Fax Number)

Date: _____

Page _____ of _____