

**CONTRACT DOCUMENTS &
TECHNICAL SPECIFICATIONS**

PWC2526102

**LIFT STATION 33 CARGILL LIFT STATION STRUCTURAL
REPAIR**

ISSUED FOR BID

May 28, 2026

**Fayetteville Public Works Commission
Administrative Building
955 Old Wilmington Road
Fayetteville, NC 28301**

TABLE OF CONTENTS

SECTION A – PROJECT SPECIFICS

General

Advertisement for Bids

00100 – Instructions to Bidders

Bid Submittal Documents

Bid Schedule – Performance and Delivery

Bid Checklist

00300 – Bid Pricing Form

Contractor Qualification Forms

Bid Supplemental Forms and Attachments

Small and Disadvantaged Business Enterprise (SDBE) Program

SDBE Program Forms

SDBE/SLS Disclosure Form

SECTION B – CONTRACT EXECUTION DOCUMENTS

Notice of Award

Acceptance of Award

Construction Agreement

PWC General Conditions

Contract Supplemental Forms and Attachments

Notice to Proceed

SECTION C – ADMINISTRATIVE PROVISIONS

DIVISION 1 – GENERAL REQUIREMENTS

01025 – Measurement and Payment

01300 – Submittals

01310 - Construction Schedule

01400 – Quality Control

01700 – Project Closeout

SECTION D – TECHNICAL SPECIFICATIONS

DIVISION 2 – SITE WORK

02750 - Wastewater Flow Control *rev 9.8.19*

APPENDICES

Appendix A – Drawings

Appendix B – Access Maps

SECTION A – PROJECT SPECIFICS GENERAL

***** THIS PAGE WAS INTENTIONALLY LEFT BLANK *****

**ADVERTISEMENT FOR BID
FAYETTEVILLE PUBLIC WORKS COMMISSION
LIFT STATION 33 CARGILL LIFT STATION STRUCTURAL REPAIR**

**Cumberland County
North Carolina**

Pursuant to N.C.G.S 143-129, sealed bids are solicited and will be received at Fayetteville Public Works Commission, Administration Building, Conference Room 107, 955 Old Wilmington Road, Fayetteville, NC 28301, until **2:00 p.m., EST Wednesday, June, 10, 2026**, at which time they will be publicly opened and read.

Cargill Lift Station design replacement for deteriorated structural steel and aluminum elements at existing wet well. contractor is to demolish existing handrails, grating, grating supports, pipe supports, etc. and properly dispose, leave existing pump equipment, piping, metering devices, etc. in place but temporarily detach as required by PWC. Coordinate minor relocations with PWC or temporary detachments with PWC during pre-construction conference with PWC.

Below is the following pump data for bypass pumping:

Pump 1
Dynamic
Suction: 21 ft
Discharge: 20 ft
Rpm: 1041

Pump 2
Dynamic
Suction: 21 ft
Discharge: 18 ft
Rpm: 1045

Using pump curve for GR T8 pump:
Rpm: 1050
TDH: 40 ft average
Pump curve flows approximately 1,690 gpm

Pump 1 average run time: 3 min 20 sec (SCADA)
Pump 1 average flow per cycle: 5,633 gal/cycle

Pump 2 average run time: 3 min 7 sec (SCADA)
Pump 2 average flow per cycle: 5,267 gal/cycle

The foregoing description shall not be construed as a complete description of all work required. All work shall be done in accordance with PWC technical specifications and standard contract terms.

Individual telephone inquiries are prohibited. PWC assumes no responsibility to fully inform absentees of clarifications not issued by addendum.

Bids must be enclosed in a sealed envelope addressed to Shelby Lesane, Procurement Advisor II, Fayetteville Public Works Commission, 955 Old Wilmington Road, Fayetteville, North Carolina 28301. The outside of the envelope must be marked **SEALED BID: LIFT STATION 33 CARGILL LIFT STATION STRUCTURAL REPAIR** and shall indicate the name, address and state license number of the bidder. Bids shall be submitted on the printed forms, or exact copies thereof, contained in the Contract Documents.

Each bid shall be accompanied by a bid bond of five percent (5%) of the bid executed by a surety company licensed under the laws of North Carolina to execute the Contract in accordance with the bid bond and upon failure to forthwith make payment, the surety shall pay the obligee an amount equal to the amount of said bond. Said deposit shall be retained by the Owner as liquidated damages in event of failure of the successful bidder to execute the Contract within ten (10) days after the Notice of Award or give satisfactory surety as required by law.

Performance and Payment Bonds are required in the amount of 100% of the Contract amount and shall be furnished by the Contractor. All Contractors are notified that North Carolina Statutory provisions as to licensing of Contractors will be followed as applicable in receiving and evaluating bids and in reading and awarding the Contract (Chapter 87 of the North Carolina General Statutes).

The license classification shall be:

Part 1:	Public Utilities (Water and Sewer)	-	Unlimited
	Unclassified	-	Unlimited

Plans and Specifications including Contract Documents will be available online for viewing and downloading on or about **Wednesday, May 27, 2026**, on the PWC Procurement website at <https://www.faypwc.com/purchasing>. In addition, the documents will be available from the Fayetteville State University Construction Resource Office (FSU CRO) at <https://www.uncfsu.edu/academics/colleges-schools-and-departments/broadwell-college-of-business-and-economics/outreach-centers/construction-resource-office>. In collaboration with the North Carolina Institute of Minority Economic Development, the FSU CRO offers services and support to help small, minority, veteran, and women-owned businesses identify and compete for construction-related projects.

At the FSU CRO, potential bidders may:

- Research, view and print project drawings to scale free of charge;
- Use available software to prepare their bid; and
- Receive certification and pre-qualification assistance.

Please email the FSU CRO to make an appointment: fsucro@uncfsu.edu

Plans and Specifications are also being furnished to ISQFT (www.isqft.com) for online posting. Purchase of the documents is not required to bid.

Fayetteville Public Works Commission reserves the right to reject any and all bids, to waive any and all informalities and irregularities, and to disregard all nonconforming, nonresponsive, or conditional bids. PWC further reserves the right to request additional information from any or all

bidders for evaluation purposes; failure or refusal to furnish such information as requested may result in rejection of the bid.

The bid tabulation and announcement of the apparent low bidder at the bid opening do not constitute a binding contract with PWC. No contract will be considered awarded until a formal written Agreement is executed by both PWC and the successful bidder. The award of a contract, if made, will be to the lowest responsible, responsive bidder whose qualifications indicate the award will be in the best interest of PWC.

PWC also reserves the right, at its sole discretion, to re-advertise for bids if deemed in the best interest of PWC.

The bidder to whom the contract may be awarded must comply fully with the requirements of North Carolina General Statutes Section 143-129, as amended.

No bids may be withdrawn after the scheduled Bid Opening for a period of hundred twenty (120) calendar days.

FAYETTEVILLE PUBLIC WORKS COMMISSION
Nikole Bohannon
Procurement Manager

**00100 - INSTRUCTIONS TO BIDDERS
FAYETTEVILLE PUBLIC WORKS COMMISSION
LIFT STATION 33 CARGILL LIFT STATION STRUCTURAL REPAIR**

A. DEFINED TERMS

Terms used in these Instructions to Bidders are defined in the Definitions and Terminology sections of PWC General Conditions.

B. COPIES OF BIDDING DOCUMENTS

1. Complete sets of the Bidding Documents as stated in the Invitation to Bidders, may be obtained from the PWC Procurement Department.
2. Complete sets of Bidding Documents shall be used in preparing Bids. PWC assumes no responsibility for errors or misinterpretations resulting from the use of incomplete sets of Bidding Documents.

C. EXAMINATION OF CONTRACT DOCUMENTS, OTHER RELATED DATA, AND PROJECT SITE

1. Before submitting a Bid, each Bidder shall (a) examine the Contract Documents thoroughly, (b) visit the site and become familiar with the site and any local conditions that may in any manner affect the cost, progress, or performance of the Work, (c) be familiar with federal, state and local laws, ordinances, rules and regulations that may in any manner affect cost, progress or performance of the Work, and (d) study and carefully correlate Bidder's observations with the Contract Documents, and (e) give the PWC Procurement Advisor written notice of all conflicts, errors or discrepancies in the Contract Documents.
2. Bidders should consult the Specifications for the identification of those reports of investigations and tests of subsurface and latent physical conditions at the site or reports that otherwise may affect cost, progress, or performance of the Work which may have been utilized in the preparation of the Drawings and Specifications. PWC will make copies of such reports if available at the cost (non-refundable) of reproduction to any Bidder requesting them. These reports are not intended to constitute any explicit or implicit representation as to the nature of the subsurface and latent physical conditions, which may be encountered at the site or to constitute explicit or implicit representations as to any other matter, contained in any report. Such reports are not guaranteed as to accuracy or completeness and are not part of the Contract Documents. Before submitting a Bid, each Bidder will, at its own expense, make such investigations and tests as the Bidder may deem necessary to determine his Bid for the performance of the Work in accordance with the Contract Documents.
3. On request (minimum 48 hours advance notice), PWC will provide each Bidder access to the site to conduct such investigations and tests, as each Bidder deems necessary for submission of its Bid.
4. The lands upon which the Work is to be performed, right-of-way for access thereto, and other lands available for use by the Contractor in performing the Work are identified in the Contract Documents.

5. The submission of a Bid constitutes an incontrovertible representation by the Bidder that it has complied with every requirement of this Section and that the Contract Documents are sufficient in scope and detail to indicate and convey an understanding of all terms and conditions for the performance of the Work.

D. INTERPRETATIONS AND ADDENDA

1. All questions about the meaning or intent of the bid or Contract Documents shall be submitted in writing to Shelby Lesane, Procurement Advisor II, by email to procurement@faypwc.com. In order to receive consideration, questions must be received by Tuesday, June 2, 2026 @ 5:00 p.m. Any interpretations of questions so raised, which in the opinion of the Project Engineer require interpretations, will be issued by Addenda via email or posted online by the Owner and/or Project Engineer. An Addendum extending the Bid Opening date may be issued up to five (5) business days before the Bid Opening date. An Addendum withdrawing the Invitation for Bid may be issued any time prior to the Bid Opening date. The Owner and Project Engineer will not be responsible for oral interpretations or clarifications, which anyone presumes to make on their behalf.

Bidders are expressly prohibited from contacting any PWC official or employee associated with this project, except as noted above. Violation of this prohibition is grounds for the immediate disqualification of the bidder.

2. PWC may issue such additional Addenda as may be necessary to clarify, correct, or change the Contract Documents. Such Addenda, if any, will be issued in the manner and within the time stated in Paragraph 1 of this Section.
3. Each Bidder shall be responsible for determining that all Addenda issued by PWC have been received before submitting a Bid for the Work.
4. Each Bidder shall acknowledge the receipt of each Addendum on the Bid Form.

E. VENDOR REGISTRATION VIA ISUPPLIER

1. All vendors interested in doing business with PWC must register as a vendor through the iSupplier Portal using the link below. The iSupplier self-service portal enables vendors to have real-time access to information regarding purchase orders, invoices, and payments through a secure environment. Attach a copy of your W9 to your online registration.

<https://www.faypwc.com/isupplier-doing-business-with-pwc/>

F. QUALIFICATION OF CONTRACTORS

1. **Bidder Qualification Form** – The Bid package shall include the completed Contractor Qualification Form and all supporting documentation.
2. **Statutory Requirements** – The Bidder shall comply with all federal, state, and local statutes, regulations, and codes as they relate to the Project. Failure to comply with these requirements shall be considered a breach of Contract.
3. Contractor to provide utility references for similar projects completed by identified crews.
4. PWC is looking for utility contractors with experienced personnel in all facets of water and/or sewer main replacement services. The minimum work experience of the following

Personnel Classifications will be required:

- **Superintendent:** Must have a minimum of 10 years of experience as a superintendent, coordinating and managing all aspects of sewer and/or water construction projects.
- **Foreman/Crew Leader:** Must have a minimum of 8 years of experience as a foreman/crew leader, coordinating and supervising a team of crew members for sewer and/or water construction projects.
- **Operator:** Must have a minimum of 8 years of experience operating heavy equipment for sewer and/or water construction projects.

5. Equipment Requirements (Minimum)

- Excavator, 65,000 to 85,000 LB Class
- Excavator, 38,000 to 64,999 LB Class
- Excavator, 18,000 to 37,999 LB Class

Contractor will only be paid for equipment and tools in use on work-site.

G. SUBSTITUTE MATERIAL AND EQUIPMENT

The Contract, if awarded, will be on the basis of material and equipment described in the Drawings or required in the Specifications without consideration of possible substitute or "or-equal" items. The procedure for submittal of substitute or "or-equal" items for consideration is set forth in the PWC General Conditions.

H. CONTRACTOR'S LICENSE

1. No General Contractor shall engage in contracting work in the State of North Carolina unless it has been licensed under in accordance with North Carolina law.
2. Bidders are prohibited from contracting for, or bidding upon, the construction, removal, repair or improvements to or upon real property owned, controlled or leased by Fayetteville Public Works Commission without a North Carolina Contractor's License.
3. Each bidder shall indicate its North Carolina Contractor's License number on the bid envelope and the Bid Form.
4. License Classification shall be:
 - Public Utilities Water and Sewer: Unlimited
 - Unclassified: Unlimited

I. SUBCONTRACTORS

1. Contractor shall subcontract no more than 49 percent (49%) of the value of the Contract.
2. Each Bidder shall submit to PWC with its bid the List of Subcontractors, Suppliers, other persons, and organizations proposed for those portions of the Work for which such identification is required. If PWC, after due investigation has reasonable objection to any proposed Subcontractor, Supplier, other person or organization, PWC may, before Notice of Award is given, request apparent Successful Bidder to submit an acceptable substitute without an increase in the Bid.

3. If the apparent Successful Bidder declines to make such a substitution, PWC may award the Contract to the next lowest responsive, responsible Bidder that proposes to use acceptable Subcontractors, Suppliers, and other persons, and organizations. The declining to make requested substitutions will not constitute grounds for sacrificing the bid security of any Bidder. If PWC does not make written objection to a Bidder's list of Subcontractors, Suppliers, other persons, or organizations prior to giving Notice of Award, the list will be considered acceptable, subject to revocation as provided in the PWC General Conditions.

J. SMALL & DISADVANTAGED BUSINESS ENTERPRISE (SDBE) PROGRAM / SMALL LOCAL SUPPLIER (SLS) PROGRAM

1. Program Commitment: Fayetteville Public Works Commission (PWC) is committed to promoting the utilization of Small and Disadvantaged Business Enterprises (SDBEs) and Small Local Suppliers (SLS) in PWC's procurement of construction contracting. PWC seeks to provide equitable access and opportunity to qualified businesses across its operational areas.
 - The SDBE Program encourages participation from firms certified through recognized third-party agencies, including the NC Department of Administration (HUB Office), NC Department of Transportation (DBE Program), and the U.S. Small Business Administration (SBA).
 - The SLS Program continues to promote engagement of small, local firms within the Fayetteville Metropolitan Statistical Area (MSA), consisting of Cumberland, Hoke, and Harnett Counties.
2. Applicability and Bidder Requirements: For procurements of construction exceeding \$30,000, Bidders must demonstrate good-faith efforts to engage certified SDBEs and, when applicable, SLSs. This includes outreach to certified firms, solicitation of quotes, and attendance at pre-bid meetings. Documentation must include completed Affidavit forms (A-E) as outlined in the SDBE Compliance Provisions within the Contract Documents. Attendance at the Pre-Bid Meeting is strongly recommended to review program expectations and compliance procedures.
3. Certification and Verification: Certifications recognized under this program include:
 - NC Department of Transportation (NCDOT) Disadvantaged Business Enterprise (DBE)
 - NC Department of Administration (DOA) Historically Underutilized Business (HUB)
 - U.S. Small Business Administration (SBA) certifications, including 8(a), WOSB, SDVOSB, and HUBZone designations. Firms holding current certifications with these agencies are acceptable for listing in the bidder's submittal and will be counted toward participation goals. Vendor directories can be accessed via the following links:
 - NCDOT DBE Directory: <https://www.ebs.nc.gov/VendorDirectory>
 - NC HUB Directory: <https://ncadmin.nc.gov/businesses/hub>

K. SUBMISSION OF BIDS

1. All Bidders shall use the enclosed Bid Forms, or exact copies thereof, in submitting their bid prices. Failure to provide full and complete Bid Forms using the form provided herein will result in a bid being deemed non-responsive.
2. PWC will not accept modified Bid Forms, oral Bids, or Bids received by telephone, email, or telecopier (FAX machine) for this Bid.
3. All prices must be F.O.B. delivered to the point as indicated by this Bid. PWC will grant no allowance for boxing, crating, or delivery unless specifically provided for in this Bid.
4. The Bid Form must be completed in black ink. Black or blue pen ink is acceptable if handwritten. Discrepancies between amounts shown in words and amounts shown in figures will be resolved in favor of the amounts shown in words. Discrepancies in the multiplication of units of Work and the unit prices will be resolved in favor of the correct multiplication of the unit prices. Discrepancies between the indicated sum of any column of figures and the correct sum thereof will be resolved in favor of the correct sum.
5. Bid submittals sent by mail should be registered mail. The sealed Bid, marked as indicated above, should be enclosed in an additional sealed envelope similarly marked and addressed to:

Fayetteville Public Works Commission
Attn: Shelby Lesane, Procurement Advisor II
955 Old Wilmington Road
Fayetteville, North Carolina 28301

6. Mark the envelope in the lower left-hand corner with the project title, hour and due date of Bid, and the Bidder's North Carolina contractor registration number.
7. Bids sent by mail and arriving after the time for the opening of Bids shall not be considered valid Bids. In such instances, the Bidders shall have no claim against PWC.
8. All items contained in the Bid Checklist shall be completely filled out and submitted with the bid. Failure to submit any of the items requested with the Bid Form may be just cause for rejection of the Bid by PWC.
9. All erasures, insertions, additions, and other changes made by the Bidder to the Bid Form shall be signed or initialed by the Bidder. Bids containing any conditions, omissions, erasures, alterations, or items not called for in the Bid, may be rejected by PWC as being incomplete or nonresponsive.
10. The Bid Form must be signed in order to be considered. If the Bidder is a corporation, the Bid must be submitted in the name of the corporation, not simply the corporation's trade name. In addition, the Bidder must indicate the corporate title of the individual signing the Bid.
11. The Bid Form, the Bid security, if any, and any other documents required, shall be enclosed in a sealed opaque envelope. Any notation or notations on the exterior of the envelope purporting to alter, amend, modify, or revise the bid contained within the envelope shall be of no effect and shall be disregarded.

12. All Bids received in the Procurement Department by the deadline indicated will be kept sealed until the time and date of the Bid Opening.
13. All late Bids shall be returned unopened to the sender.

L. BID BOND

1. Each Bid shall be accompanied by an acceptable Bid bond in the amount of five percent (5%) of the Bid amount, and made payable to Fayetteville Public Works Commission, North Carolina.
2. The Bid bond is a guarantee that if the contract is awarded by PWC to the Bidder, the Bidder shall enter into the contract with PWC for the work mentioned in this Bid or forfeit the Bid bond to PWC, not as a penalty, but as liquidated damages.
3. No forfeiture under a Bid bond shall exceed the lesser of (a) the difference between the Bid for which the Bid bond was written and the next low Bid of another Bidder, or (b) the face amount of the Bid bond.
4. All bonds shall be executed by a surety company selected by the Bidder, which is legally authorized to do business in the State of North Carolina (NCGS §44 A-26), and the bond shall be the same in both form as well as substance as AIA Document A310, Bid Bond.
5. The Bidder shall require the attorney-in-fact, who executed the required bond on behalf of the surety company, to affix thereto a certified and current copy of the power of attorney.
6. The bond premium shall be paid by the Bidder and the cost shall be included in the Bid price.
7. Any inspection of procurement transaction records shall be subject to reasonable restrictions to ensure the security and integrity of the records.

M. OPENING OF BIDS

1. Bids will be opened publicly and read aloud on the date and time set for the Bid Opening in the Notice to Bidders.
2. Any Bidder, upon request, shall be afforded the opportunity to inspect Bid records within a reasonable time after the opening of all Bids but prior to award, except in the event that PWC decides not to accept any of the Bids and to reopen the contract. Otherwise, bid records shall be open to public inspection only after the award of the Contract.
3. Any inspection of procurement transaction records shall be subject to reasonable restrictions to ensure the security and integrity of the records.

N. MODIFICATION OF BIDS

1. A Bid may be modified or withdrawn by the Bidder at any time prior to the time and date set for the Bid Opening. The Bidder shall notify the PWC Procurement Department in writing of its intentions.
2. Modified and withdrawn Bids may be resubmitted to the PWC Procurement Department up to the time and date set for the Bid Opening.

O. WITHDRAWAL OF BID DUE TO ERROR

1. If the Bidder desires to withdraw its Bid, the Bidder must do so before the time fixed for the opening, without prejudice, by communicating its purpose in writing to PWC. After bids are open, bids may only be withdrawn in strict accordance with N.C.G.S. Section 143-129-1.

P. BIDS TO REMAIN OPEN

1. All Bids shall remain open for one hundred twenty (120) calendar days after the day of the Bid Opening.

Q. ESTIMATED QUANTITIES

1. The estimated quantities contained herein in certain items in the Bid are for the purpose of comparing bids, and while they are believed to be close approximations, they are not guaranteed, and settlement will be made on the basis of the work as actually executed at the unit prices in the Bid as accepted. PWC further reserves the right to delete any single line item or combination of items from the bid and cannot guarantee that all quantities listed in the Contract Documents will be utilized.
2. The Contractor should verify quantities before submitting a bid. Due to conditions that may be found under pavement such as the accurate location of existing water lines, sewer lines, gas lines, and structure services of all types, quantities are subject to change during construction, but this contingency shall not be used for a claim to change unit prices submitted in the Bid.

R. AWARD OF CONTRACT

1. PWC reserves the right to reject any and all bids, to waive any and all minor informalities and irregularities, and to disregard all nonconforming, nonresponsive, or conditional bids. PWC further reserves the right to request additional information from any or all bidders for evaluation purposes; failure or refusal to furnish such information as requested may result in rejection of the bid. The bid tabulation and announcement of the apparent low bidder at the bid opening do not constitute a binding contract with PWC. No contract will be considered awarded until a formal written Agreement is executed by both PWC and the successful bidder. The award of a contract, if made, will be to the lowest responsible, responsive bidder whose qualifications indicate the award will be in the best interest of PWC. PWC also reserves the right, at its sole discretion, to re-advertise for bids if deemed in the best interest of PWC.
2. In case of a tie Bid, the tie shall be decided by lot.
3. It is the intent of PWC to recommend the award of this contract to the lowest responsive, responsible Bidder provided the Bid has been submitted in accordance with the requirements of the Bidding Documents and does not exceed the funds available. In determining the lowest responsible Bidder, PWC may consider, among other criteria, the Bidder's past performance conduct on other contracts, and other information provided by the Bidder as noted below.
4. In determining the lowest responsive Bidder, PWC will evaluate the Bidder's proposed Bid price and the completeness of the submitted bid in accordance with the requirements of

the Contract Documents.

5. PWC may consider the operating costs, maintenance considerations, performance date, and guarantees of materials and equipment.
6. PWC may conduct such investigations as deemed necessary to assist in the evaluation of any Bid and to establish the responsibility, qualifications and financial ability of the Bidders, as well as other considerations, to include but not limited to resources available to the Bidder to perform the work effectively, proposed Subcontractors and other persons and organizations to do the work in accordance with the Contract Documents to PWC's satisfaction within the prescribed time.
7. PWC reserves the right to reject the Bid of any Bidder who does not pass any such evaluation to PWC's satisfaction.
8. If the Contract is to be awarded, PWC will give the Successful Bidder a Notice of Award within one hundred twenty (120) days after the day of the Bid Opening.
9. The Bidder to whom the contract is awarded shall, within ten (10) days after prescribed documents are presented for signature, execute and deliver the Contract Documents and any other forms or bonds required by the Bid to PWC.
10. The Bidder is required to complete the attached forms that will allow PWC to verify that the Bidder is qualified to perform the Work described in these Contract Documents. All forms shall be completed and submitted with the Bid. Failure to submit all the required forms shall be considered grounds for PWC to reject the bid.

PWC will review all of the bids and qualification data to determine the lowest responsive, responsible Bidder. PWC reserves the right to not award the Contract to the lowest bidder if the information provided is not complete, does not meet the satisfaction of PWC, or has been falsified. PWC will not request any additional information in order to allow the Contractor to complete bid.

11. During the evaluation phase, bid submittals will be reviewed to ascertain which bids technically and otherwise address all the requirements of these Contract Documents. Bid submittals determined to be technically non-responsive or not sufficiently responsive may be disqualified.

The Bidder shall address each of the Evaluation Criteria as requested in the Technical Evaluation Criteria Form located within Section A Project Specifics Bid Submittal Documents. To be considered substantive, the information must respond to all requirements.

12. PWC may conduct such investigations/verifications as deemed necessary to establish the responsibility, qualification and financial ability of the Bidder. Should PWC find that the apparent low bidder is not the lowest responsive, responsible bidder by integrity of the information furnished, said apparent low bidder will be so notified and its bid bond shall be returned without prejudice. Failure or refusal to furnish any items of information requested by PWC shall be considered as non-responsive and therefore basis for rejection of the bid.

S. TAXES

1. The Successful Bidder shall pay all county, city, state and federal taxes required by laws in effect at the time Bids are received and resulting from the Work or traceable thereto, under whatever name levied.
2. Said taxes shall not be in addition to the contract price between PWC and the Successful Bidder. The taxes shall be an obligation of the Successful Bidder and not of PWC. PWC shall be held harmless from same by the Successful Bidder.

T. PERFORMANCE AND OTHER BONDS

1. The PWC General Conditions set forth PWC's requirements as to Performance and other Bonds.

U. E-VERIFY REQUIREMENTS

1. Contractor hereby acknowledges that "E-Verify" is the federal E-Verify program operated by the US Department of Homeland Security and other federal agencies which is used to verify the work authorization of newly hired employees pursuant to federal law and in accordance with Article 2, Chapter 64 of the North Carolina General Statutes.
2. Contractor further acknowledges that all employers, as defined by Article 2, Chapter 64 of the North Carolina General Statutes, must use E-Verify and after hiring an employee to work in the United States, shall verify the work authorization of the employee through E-Verify in accordance with NCGS §64-26(a).
3. Contractor hereby pledges, attests and warrants through execution of this Agreement that Contractor complies with the requirements of Article 2, Chapter 64 of the North Carolina General Statutes and further pledges, attests and warrants that any subcontractors currently employed by or subsequently hired by Contractor shall comply with any and all E-Verify requirements. Failure to comply with the above requirements shall be considered a breach of this Agreement.

V. IRAN DIVESTMENT ACT

1. As mandated by N.C.G.S. 147-86.59(a), the Contractor hereby certifies that it is not listed on the Final Divestment List created by the North Carolina State Treasurer pursuant to N.C.G.S. 147-86.58. Contractor further certifies that in accordance with N.C.G.S. 146-86.58(b) that it shall not utilize any subcontractor found on the State Treasurer's Final Divestment List. Contractor certifies that the signatory to this Purchase Order authorized by the Contractor to make the foregoing statement.

*** END OF SECTION ***

**SECTION A – PROJECT SPECIFICS
BID SUBMITTAL DOCUMENTS**

**BID SCHEDULE – PERFORMANCE AND DELIVERY
FAYETTEVILLE PUBLIC WORKS COMMISSION
LIFT STATION 33 CARGILL LIFT STATION STRUCTURAL REPAIR**

Deadline for Questions from Bidders ¹	5:00pm, Tuesday, June 2, 2026
Deadline for Addenda issued by PWC Procurement Department and Project Engineer ²	5:00pm, Thursday, June 4, 2026
Bid Opening (Submittal Deadline)	2:00pm, Wednesday, June 10, 2026 Fayetteville Public Works Commission Administrative Building Conference Room 107 955 Old Wilmington Road Fayetteville, NC 28301
Target Commission Meeting	Wednesday, July 9, 2026
Target City Council Meeting	Monday, August 10, 2026
Contract Time:	120 Calendar days
Liquidated Damages:	\$1,000.00 per day for each day beyond the Final Completion Date
Bid Acceptance Period	Within one hundred twenty (120) Calendar Days unless otherwise noted

-
1. Questions regarding this bid must be submitted in writing to the attention of Shelby Lesane, Procurement Advisor II, by email to procurement@faypwc.com.

Bidders are expressly prohibited from contacting any FPWC official or employee associated with this Invitation to Bid, except as noted above. Violation of this prohibition is grounds for the immediate disqualification of the bidder.

2. Any addenda to these Contract Documents will be issued by the Project Engineer no later than the date and time stated above.

BID SUBMITTAL CHECKLIST

- 1. Enter Contractor's License Number where called for in the Bid Form and on the outside of the sealed envelope containing the Bid.
- 2. Photocopy of Contractor's License.
- 3. Bid Bond
- 4. Bid Forms Section 00300.
- 5. Provide the responsible North Carolina Registered Agent for Insurance Claims. Include contact information.
- 6. Provide the proposed responsible Bonding Company name. Include contact information.
- 7. List of proposed Subcontractors and material suppliers exceeding 5% of the Contract Value.
- 8. Non-Collusive Affidavit.
- 9. Nondiscrimination Clause.
- 10. Affidavit of Organization and Authority and Sworn Statement.
- 11. Equal Employment Opportunity Acknowledgment.
- 12. Certification regarding Debarment, Proposed Debarment, and other Responsible Matters.
- 13. FTA Certification Regarding Lobbying.
- 14. Affidavit A – Listing of Good Faith Efforts, et al.
- 15. Affidavit B – (Only if the Contractor will perform **ALL ELEMENTS OF THE WORK** on this project with their own forces **AND** will complete **ALL ELEMENTS OF THIS PROJECT WITHOUT THE USE OF SUBCONTRACTORS, MATERIAL SUPPLIERS, OR PROVIDERS OF PROFESSIONAL SERVICES.**
- 16. Affidavit E - Identification of Minority Business Participation Form.
- 17. SLS / SDBE Disclosure Form.
- 18. The Completed Contractor Qualification Form.

****FAILURE TO SUBMIT THE ABOVE FORMS WITH THE BID FORM PROVIDED HEREIN MAY BE JUST CAUSE FOR REJECTION OF THE BID BY THE OWNER****

***** THIS PAGE INTENTIONALLY LEFT BLANK *****

00300 - BID FORM

TO: **Fayetteville Public Works Commission**
Attn: Shelby Lesane, Procurement Advisor II
955 Old Wilmington Road
Fayetteville, North Carolina 28301

PROJECT: **PWC2526102 - LIFT STATION 33 CARGILL LIFT STATION STRUCTURAL REPAIR**

FROM: BIDDER _____
ADDRESS _____

DATE OF BID _____, 20 _____

- A. The undersigned BIDDER proposes and agrees, if this Bid is accepted, to enter into a Contract with OWNER in the form included in the Contract Documents to perform and furnish all Work (as that term is defined in the Construction Agreement) specified or indicated in the Contract Documents for the Contract Price and within the Contract Time indicated in this Bid and in accordance with the Contract Documents.
- B. BIDDER accepts all of the terms and conditions of the Instructions to Bidders, including, without limitation, those dealing with the disposition of payment and performance bonds, and insurance certificates. This bid will remain open for one hundred twenty (120) calendar days after the day of Bid opening. BIDDER will sign the Contract and submit the Contract Security and other documents required by the Contract Documents within ten (10) days after the date of receipt by the BIDDER.
- C. In submitting this Bid, Bidder represents, as more fully set forth in the Contract, that:
 - 1. BIDDER has examined copies of all the Contract Documents and of the following addenda, receipt of all which is acknowledged on the bid summary page:
 - 2. BIDDER has examined the site and locality where the Work is to be performed, the legal requirements (federal, state, and local laws, ordinances, rules and regulations) and the conditions affecting cost, progress of performance of the work and has made such independent investigations as BIDDER deems necessary.
 - 3. BIDDER acknowledges that OWNER does not assume responsibility for the accuracy of dimensions or completeness of information and data shown or indicated in the Bidding Documents with respect to existing facilities.
 - 4. BIDDER has carefully studied all reports of explorations and tests of subsurface conditions at or contiguous to the site of the Work (except underground facilities)

and all drawings of physical conditions in or relating to existing surface or subsurface structures, pipelines, and utilities at or contiguous to the site are provided within these Contract Documents. Geotechnical Reports and other information regarding subsurface conditions are identified in the attached appendices and detailed in Article V of the PWC General Conditions. BIDDER acknowledges that the OWNER does not assume responsibility for the accuracy or completeness of information and data shown or indicated in the Bidding Documents with respect to underground facilities at or contiguous to the site of Work. BIDDER had obtained and carefully studied (or assumes responsibility for have done so) all such additional or supplementary examinations investigations, explorations, tests, studies, and data that are necessary to identify and understand conditions (surface, subsurface, and underground facilities) at or contiguous to the site of Work or otherwise which may affect cost, progress, performance, or furnishing the Work or which relate to any aspect of means, methods, techniques, sequences, and procedures of construction to be employed by Bidder and safety precautions and programs incident thereto. BIDDER waives all rights to claim that any additional examinations, investigations, explorations, tests, studies, or data are necessary for the proper submission of the Bid for the performance and furnishing of the Work in accordance with the Contract Time, Contract Price, and other terms and conditions of the Contract Documents.

5. BIDDER hereby certifies that, if awarded the Contract for construction of the Project, it will take all possible actions to minimize costs to the OWNER which are related to any disruptions in any part of the Work resulting from unforeseeable conditions which may be encountered and work changes or additions which may be made.
6. BIDDER has correlated the information known to BIDDER, information and observations obtained from visits to the site, reports and drawings identified in the Contract Documents, and all additional examinations, investigations, exploration, tests, studies, and data with the Contract Documents.
7. BIDDER has given OWNER written notice of all conflicts, errors, ambiguities, or discrepancies that BIDDER has discovered in the Contract Documents and the written resolution thereof by OWNER is acceptable to BIDDER, and the Contract Documents are generally sufficient to indicate and convey understanding of all terms and conditions for performing and furnishing the Work for which this Bid is submitted.
8. By bidding in response to this invitation, the BIDDER represents that in the preparation and submission of this Bid, said BIDDER did not, either directly or indirectly, enter into any combination or arrangement with any person, firm or corporation or enter into any agreement, participate in any collusion, or otherwise take any action in the restraint of free, competitive bidding in violation of the Sherman Act (15 U.S.C. Section 1).
9. Bid form must be completed in blue or black ink or by typewriter. The Bid price of

each item on the form must be stated in both words and numerals. In case of a conflict, words shall take precedence. Discrepancies in the multiplication of units of work and unit prices will be resolved in favor of the correct multiplication of the unit prices. Discrepancies between the indicated sum of any column of figures and the correct sum thereof will be resolved in favor of the correct sum.

10. BIDDER understands that the award of contract will be made on the basis of the total Bid amount which will be determined as the sum of the unit price and lump sum Bid Items.
11. BIDDER understands that quantities are estimated and are not guaranteed; they are solely for comparing Bids and establishing the total Bid amount. The Price will be modified by Change Order, and final payment will be based on the quantities of work actually furnished and installed by the successful BIDDER.
12. BIDDER shall complete the Work for the prices indicated on the next page.

Bidder Name: _____

Fayetteville PWC Cargill Lift Station Structural Repairs					
Item No.	Measurement & Payment Description	Qty	Unit	Unit Price	Cost Extension
1.01	Cargill Lift Station Structural Repairs	1	LS		

TOTAL BASE BID \$ _____

The undersigned BIDDER hereby agrees to accept an award of the Contract based on the Total Contract Amount as accepted by the OWNER and as indicated on the Notice of Award.

A. BIDDER agrees that Work shall be completed within the time frame indicated in the Agreement as follow:

1. All work described herein to be complete, including restoration and all punch list items from Notice to Proceed until the competition date noted in the Notice to Proceed.
2. The BIDDER acknowledges that time is of the essence in this Contract and that the OWNER will suffer financial loss if the Work is not complete within the time specified in Paragraph D.1 above plus any extensions thereof allowed in accordance with these Contract Documents. BIDDER also recognizes the delays, expense and difficulties involved in proving in a legal proceeding the actual loss suffered by the OWNER if the Work is not complete on time. The Bidder agrees to diligently pursue all available work and complete all work in an expeditious manner.

B. The following documents are attached to and made part of this bid:

Required Bid Security in the form of either a cashier's check or certified check or Bid Bond in the amount of 5% of maximum Bid price.

Communications concerning the Bid Bond shall be addressed to: (**SURETY'S** Name, Address, Telephone Number, and email address)

Failure to provide full and complete information will result in a bid being deemed non-responsive.

C. Communications concerning this Bid shall be addressed to: (**CONTRACTOR's** Name, Address, Telephone Number, and email address)

Failure to provide full and complete information will result in a bid being deemed non-responsive.

D. The terms used in this Bid which are defined in Definitions and Terminology Section of the

PWC General Conditions or as otherwise specifically defined in the Contract Documents have the meanings assigned to them therein, which are incorporated by reference as if fully set forth herein.

- E. An individual contractor is required to furnish his social security number and sole proprietorship, partnership and corporation are required to furnish their employer identification numbers to Fayetteville Public Works Commission. Please indicate this information on this Bid Form as follows:

Social Security Number: _____

Federal Employer Identification Number: _____

SUBMITTED ON ____ day of _____ 2026

AN INDIVIDUAL

BY: _____ (SEAL)
(Individual's Name and Signature)

Doing Business as: _____

North Carolina Contractor Registration Number: _____

Business Address: _____

Phone Number: _____

Subscribed and sworn to before me this ____ day of _____ 2026

NOTARY PUBLIC
My Commission Expires: _____

A PARTNERSHIP

BY: _____ (SEAL)
(Firm Name)

(General Partner and Signature)

North Carolina Contractor Registration Number: _____

Business Address: _____

Phone Number: _____

Subscribed and sworn to before me this ____ day of _____ 2026

NOTARY PUBLIC

My Commission Expires: _____

A CORPORATION

BY: _____
(Corporation Name) (State of Incorporation)

BY: _____ (SEAL)
(Name and Title of Person Authorized to Sign and Signature)

ATTEST: _____
(Secretary or Assistant Secretary and Signature)

North Carolina Contractor Registration Number: _____

Business Address: _____

Phone Number: _____

Subscribed and sworn to before me this ____ day of _____ 2026

NOTARY PUBLIC

My Commission Expires: _____

A JOINT VENTURE

BY: _____

(Name and Signature)

Doing Business as: _____

North Carolina Contractor Registration Number: _____

Business Address: _____

Phone Number: _____

Subscribed and sworn to before me this ____ day of _____ 2026

NOTARY PUBLIC

My Commission Expires: _____

(Each joint venturer must sign. The name of signing for each individual, partnership, and corporation that is a party to the joint venture should be in the manner indicated above.)

*******TO BE SUBMITTED WITH BID PACKAGE*******
TECHNICAL EVALUATION CRITERIA FORM
PROJECT DOCUMENTATION

(1) Permanent Name of Business:

(2) Permanent address:

(3) Length of Time in Business:	
---------------------------------	--

(4) Has the organization operated under any other name?	
---	--

(5) State the names and/or companies financially interested in the proposal:	
--	--

(6) Within the last five (5) years, has any officer or principal of the organization ever been an officer or principal of another organization when it failed to complete a construction contract? If yes, list name(s), and responsibility.	
--	--

UTILITY RETROFIT EXPERIENCE/WATER AND SEWER MAIN EXPERIENCE

(1) List not less than three (3) completed retrofit projects of similar size, scope, nature, and cost, to include the dates of such projects. Please provide all requested information for each listed project. Each project should be from separate references. List only those projects completed as Prime Contractor.

Project 1A:	Cost:
-------------	-------

Location:	Dates:	Size:
-----------	--------	-------

Scope:	Client:	Phone:
--------	---------	--------

Project 1B:	Cost:
-------------	-------

Location:	Dates:	Size:
-----------	--------	-------

Scope:	Client:	Phone:
--------	---------	--------

--	--

Project 1C:		Cost:
Location:	Dates:	Size:
Scope:	Client:	Phone:
(2) A listing of three (3) water and/or sewer main projects of similar size, scope and cost. (Provide reference information as stated in #1.)		
Project 2A:		Cost:
Location:	Dates:	Size:
Scope:	Client:	Phone:
Project 2B:		Cost:
Location:	Dates:	Size:
Scope:	Client:	Phone:
Project 2C:		Cost:
Location:	Dates:	Size:
Scope:	Client:	Phone:
(3) List any subcontracting experience on retrofit projects with specifics to the type of work performed for this project. Please provide all requested information.		
Project:		Cost:
Location:	Dates:	Size:

Work Performed:		
Project:		Cost:
Location:	Dates:	Size:
Work Performed:		
Project:		Cost:
Location:	Dates:	Size:
Work Performed:		
(4) List of projects in progress. Please provide all requested information.		
Project:		Cost:
Owner:		
Percentage Complete:		Scheduled Completion Date:
Project:		Cost:
Owner:		
Percentage Complete:		Scheduled Completion Date:
Project:		Cost:

Owner:	
Percentage Complete:	Scheduled Completion Date:
Project:	
Project:	Cost:
Owner:	
Percentage Complete:	Scheduled Completion Date:
Project:	
Project:	Cost:
Owner:	
Percentage Complete:	Scheduled Completion Date:
Project:	
Project:	Cost:
Owner:	
Percentage Complete:	Scheduled Completion Date:
PROJECT PERSONNEL AND EXPERIENCE	
(1) The number of crews qualified and available to perform the work stated in this proposal:	
(2) The names of Bidder superintendents and crew leaders/foreman who are qualified and available to perform the work stated in this proposal:	Superintendents:
	Crew leaders/foreman:
ADDITIONAL ITEMS	
The following items shall be submitted as attachments:	
(1) Affidavit stating any OSHA violations occurring within the past three (3) years.	
(2) A statement provided by the Surety Company stating the Bidder's bonding limit and a statement of the amount of work currently under bond.	
(3) A statement listing any judgments, claims, arbitration proceedings, or suits pending or outstanding against organization or its officers.	
(4) A statement listing any filed lawsuits, judgments, claims, arbitration proceedings, or suits pending with regard to construction contracts within the last five (5) years.	

(5) The resumes or brief summary of key personnel of the organization. Identify the person that will be primarily responsible for the project.	
(6) List of equipment that is available for use on the subject project.	
The Owner may conduct such investigations/verifications as deemed necessary to establish the responsibility, qualification and financial ability of the Bidder. Should the Owner adjudge that the apparent low bidder is not the lowest responsive, responsible bidder by virtue of the above information furnished, said apparent low bidder will be so notified and his bid security shall be returned to him without prejudice. Failure or refusal to furnish any items of information requested by the Owner shall be considered as non-responsive and therefore, basis for rejection of the bid.	
Submitted By:	Date:
Printed Name:	Title:

LIST OF SUBCONTRACTORS

In compliance with the Instructions to Bidders and the Supplementary Conditions, the undersigned submits the following names of Subcontractors to be used in performing the Work.

The Bidder certifies that all Subcontractors listed are eligible to perform the Work and that all Subcontractors performing more than five percent of the work are listed.

<u>Subcontractor's Name</u>	<u>Subcontractor's Work</u>	<u>% of Work</u>
_____	_____	_____ %
_____	_____	_____ %
_____	_____	_____ %
_____	_____	_____ %
_____	_____	_____ %

Bidder's Signature

BID BOND

This is a Bid Bond that is subject to the provisions of Article 3 of Chapter 44A of the North Carolina General statutes.

This Bond is executed on _____, 20 ____ .

The name of the PRINCIPAL is _____ (1)

_____ (2)

The name of the SURETY is _____

Fayetteville Public Works Commission, Fayetteville, North Carolina is the OWNER

The amount of the Bond is _____

_____ (Dollars) (\$ _____)

KNOW BY ALL MEN BY THESE PRESENTS, the Principal and Surety above named are hereby held and firmly bound unto the above named OWNER hereinafter called the OWNER in the penal sum of the amount stated above in lawful money of the United States, for the payment of which, well and truly to be made, we hereby jointly and severally bind ourselves, our heirs, executors, administrators, successors and assigns.

The condition of the above obligation is such that whereas the Principal has submitted to the OWNER a certain Bid, attached hereto and hereby made a part hereof to enter into a Contract in writing, for the construction of:

PWC2526102 - LIFT STATION 33 CARGILL LIFT STATION STRUCTURAL REPAIR

NOW, THEREFORE

- (a) If said Bid shall be rejected, or in the alternate,
- (b) If said Bid shall be accepted and the Principal shall execute and deliver a Contract in the Form of Contract attached hereto (properly completed in accordance with said Bid) and shall furnish a bond for his faithful performance of said Contract, and for the payment of all persons performing labor or furnishing materials in connection therewith, and shall in all other respects perform the agreement created by the acceptance of said Bid, then this obligation shall be void, otherwise the same shall remain in force and effect; it being expressly understood and agreed that the liability of the Surety for any and all claims hereunder shall, in no event, exceed the penal amount of this obligation as herein stated.

The Surety, for value received, hereby stipulates and agrees that the obligations of said Surety and its Bond shall be in no way impaired or affected by any extension of the time within which the Owner may accept such Bid; and said Surety does hereby waive notice of any such extension.

IN WITNESS WHEREOF, the Principal and the Surety have hereunto set their hands and seals, and such of them as are corporations have caused their corporate seals to be hereto affixed and these presents to be signed by their proper officers, the day and year first set forth above.

ATTEST:

(Principal Secretary)
(SEAL)

Principal

BY: _____ (3)

(Address)

Witness as to Principal

Surety

(Address)

(Address)

ATTEST:

N.C. Resident Agent
(SEAL)

Witness as to Surety

(Address)

- (1) Correct name of Contractor
- (2) A Corporation, a Partnership or an Individual, as the case may be
- (3) If Contractor is a Partnership, all partners should execute Bond

**POWER OF ATTORNEY
(Attach)**

**AFFIDAVIT OF ORGANIZATION AND AUTHORITY SWORN STATEMENT
PWC2526102 - LIFT STATION 33 CARGILL LIFT STATION STRUCTURAL REPAIR**

STATE OF _____

COUNTY OF _____

_____ being the first duly sworn on oath deposes and says that the Bidder on the attached Bid Form is organized as indicated below and that all statements herein made are made on behalf of such Bidder and that this deponent is authorized to make them.

(Fill Out Applicable Paragraph)

1. CORPORATION

The bidder is a corporation organized and existing under the laws of the State of _____ and its President is _____, and its Secretary is _____, and does have a corporate seal. The _____ is authorized to sign construction Contract and Bids for the company by action of its Board of Directors taken _____, a certified copy of which is hereto attached. (Strike out last sentence if not applicable.)

2. PARTNERSHIP

The Bidder is a Partnership consisting of _____ and _____, partners doing business under the name of _____.

3. SOLE TRADER

The Bidder is an individual and if operating under a trade name, such trade name is as follows:

4. ADDRESS

The business address of the Bidder is as follows:

Its phone number is _____

Bidder

By: _____

EQUAL EMPLOYMENT OPPORTUNITY

During the performance of this Contract the Contractor agrees as follows:

- a. The Contractor will not discriminate against any employee or applicant because of race, color, religion, sex, or national origin. The Contractor will take affirmative action to ensure that applicants are employed, and that employees are treated during employment, without regard to race, color, religion, sex, or national origin. Such action shall include but not be limited to the following: employment, upgrading, demotion, or transfer, recruitment or recruitment advertising, layoff or termination, rates of pay or other forms of compensation, and selection for training, including apprenticeship. The Contractor agrees to post in conspicuous places, available to employees and applicants for employment, notices setting forth the provisions of the nondiscrimination clause.
- b. The Contractor will, in all solicitations or advertisements for employees placed by or on behalf of the Contractor, state that all qualified applicants will receive consideration for employment without regard to race, color, religion, sex, or national origin.
- c. The Contractor will send to each labor union or representative of workers with which he has a collective bargaining agreement or other Contract understanding, a notice, to be provided, advising the labor union or worker's representative of the Contractor's commitments under the Equal Employment Opportunity Section of this Contract, and shall post copies of the notice in conspicuous places available to employees and applicants for employment.
- d. In the event of the Contractor's noncompliance with the nondiscrimination clauses of this Contract or with any of such rules, regulations, or orders, this Contract may be canceled, terminated, or suspended in whole or in part and the Contractor may be declared ineligible for further OWNER Contracts.
- e. The Contractor will include the provisions of this section in every subcontract or purchase order unless exempted by rules, regulations, or orders of the OWNER so that such provisions will be binding upon each Subcontractor or vendor.

(Use the following form for signatures by a CORPORATION):

Corporate Name

ATTEST:

(Assistant) Secretary

(Vice) President

(CORPORATE SEAL)

(Use the following form for signatures by and INDIVIDUAL):

BY: _____ (Seal)

WITNESS:

(ACKNOWLEDGEMENT OF THE ABOVE SIGNATURE MUST BE NOTARIZED USING FORM ON FOLLOWING PAGE)

NONDISCRIMINATION CLAUSE

It is specifically agreed as part of the consideration of the signing of this Contract that the parties hereto, their agents, officials, employees or servants will not discriminate in any manner on the basis of age, handicap, race, color, creed, sexual orientation or national origin with reference to the subject matter of this Contract, no matter how remote.

This provision being incorporated for the benefit of Fayetteville Public Works Commission, Fayetteville, North Carolina and its residents may be enforced as set out in said ordinances, enforcement of this provision shall be by action for specific performance, injunctive relief, or other remedy as by law provided.

This provision shall be binding on the successors and assigns of the parties hereto with reference to the subject matter of this Contract.

(Use the following form for signatures by a CORPORATION):

Corporate Name

ATTEST:

(Assistant) Secretary

BY: _____
(Vice) President

(Printed Name)

BY: _____
(Printed Name)

(Corporate Seal)

(Use the following form for signatures by a PARTNERSHIP or INDIVIDUAL):

BY: _____(SEAL)

(Printed Name)

WITNESS:

(Printed Name)

NON-COLLUSIVE AFFIDAVIT

State of _____)
_____)

County of _____)

_____ being first duly sworn,
deposes and says that:

- (1) He is the _____
(Owner, Partner, Officer, Representative or Agent)
of _____ the BIDDER that has
submitted the attached BID;
- (2) He is fully informed respecting the preparation and contents of the attached BID and of all
pertinent circumstances respecting such BID;
- (3) Such BID is genuine and is not a collusive or sham BID;
- (4) Neither the said BIDDER nor any of its officers, partners, owners, agents, representatives,
employees or parties in interest, including this affiant, have in any way colluded, conspired,
connived or agreed, directly or indirectly, with any other BIDDER, firm, or person to submit
a collusive or sham BID in connection with the Contract for which the attached BID has
been submitted; or to refrain from bidding in connection with such Contract; or have in any
manner, directly or indirectly, sought by agreement or collusion, or communication, or
conference with any BIDDER, firm, or person to fix the price or prices in the attached BID
or of any other BIDDER, or to fix any overhead, profit, or cost elements of the BID price
or the BID price of any other BIDDER, or to secure through any collusion, conspiracy,
connivance, or unlawful agreement any advantage against (Recipient), or any person
interested in the proposed Contract;
- (5) The price or prices quoted in the attached BID are fair and proper and are not tainted by
any collusion, conspiracy, connivance, or unlawful agreement on the part of the BIDDER
or any other of its agents, representatives, owners, employees or parties in interest,
including this affidavit.

BY _____

ITS _____
(Title)

Subscribed and sworn to before me this _____ day of _____, 20 ____ .

Notary Public

My Commission Expires:

END OF AFFIDAVIT

F.T.A. CERTIFICATION REGARDING LOBBYING

Certification for Contracts, Grants, Loans, and Cooperative Agreements

(To be submitted with each bid or offer exceeding \$100,000)

The undersigned _____ certifies, to the best of his or her knowledge and belief, that:

- (1) No federal appropriated funds have been paid or will be paid, by or on behalf of the undersigned, to any person for influencing or attempting to influence an officer or employee of an agency, a member of Congress, an officer or employee of Congress, or an employee of a member of Congress in connection with the awarding of any federal contract, the making of any federal grant, the making of any federal loan, the entering into of any cooperative agreement, and the extension, continuation, renewal, amendment, or modification of any federal contract, grant, loan, or cooperative agreement.
- (2) If any funds other than federal appropriated funds have been paid or will be paid to any person for making lobbying contacts to an officer or employee of any agency, a member of Congress, an officer or employee of Congress, or an employee of a member of Congress in connection with this federal contract, grant, loan, or cooperative agreement, the undersigned shall complete and submit Standard Form--LLL, "Disclosure Form to Report Lobbying," in accordance with its instructions [as amended by "Government wide Guidance for New Restrictions on Lobbying," 61 Fed. Reg. 1413 (1/19/96). Note: Language in paragraph (2) herein has been modified in accordance with Section 10 of the Lobbying Disclosure Act of 1995 (P.L. 104-65, to be codified at 2 U.S.C. 1601, *et seq.* .)]
- (3) The undersigned shall require that the language of this certification be included in the award documents for all subawards at all tiers (including subcontracts, subgrants, and contracts under grants, loans, and cooperative agreements) and that all subrecipients shall certify and disclose accordingly.

This certification is a material representation of fact upon which reliance was placed when this transaction was made or entered into. Submission of this certification is a prerequisite for making or entering into this transaction imposed by 31, U.S.C. § 1352 (as amended by the Lobbying Disclosure Act of 1995). Any person who fails to file the required certification shall be subject to a civil penalty of not less than \$10,000 and not more than \$100,000 for each such failure.

[Note: Pursuant to 31 U.S.C. § 1352(c)(1)-(2)(A), any person who makes a prohibited expenditure or fails to file or amend a required certification or disclosure form shall be subject to a civil penalty of not less than \$10,000 and not more than \$100,000 for each such expenditure or failure.]

The Contractor, _____, certifies or affirms the truthfulness and accuracy of each statement of its certification and disclosure, if any. In addition, the Contractor understands and agrees that the provisions of 31 U.S.C. A 3801, *et seq.*, *apply* to this certification and disclosure, if any.

_____ Signature of Contractor's Authorized Official

_____ Name and Title of Contractor's Authorized Official

_____ Date

**CERTIFICATION OF PRIMARY PARTICIPANT REGARDING DEBARMENT,
SUSPENSION AND OTHER RESPONSIBILITY MATTERS**

The Primary Participant, _____ (major third party contractor), certifies to the best of its knowledge and belief, that it and its principals:

1. Are not presently debarred, suspended, proposed for debarment, declared ineligible, or voluntarily excluded from covered transactions by any Federal department or agency;
2. Have not within a three-year period preceding this proposal been convicted of or had a civil judgment rendered against them for commission of fraud or a criminal offense in connection with obtaining, attempting to obtain, or performing a public (Federal, State or local) transaction or contract under a public transaction; violation of Federal or State antitrust statutes or commission of embezzlement, theft, forgery, bribery, falsification or destruction of records, making false statements, or receiving stolen property;
3. Are not presently indicted for or otherwise criminally or civilly charged by a governmental entity (Federal, State or local) with commission of any of the offenses enumerated in paragraph (2) of this certification; and
4. Have not within a three-year period preceding this application/proposal had one or more public transactions (Federal, State or local) terminated for cause or default.

(If the primary participant is unable to certify to any of the statements in this certification, the participant shall attach an explanation to this certification.)

THE PRIMARY PARTICIPANT _____ CERTIFIES OR AFFIRMS THE TRUTHFULNESS AND ACCURACY OF THE CONTENTS OF THE STATEMENTS SUBMITTED ON OR WITH THIS CERTIFICATION AND UNDERSTANDS THAT THE PROVISIONS OF 31 U.S.C. SECTIONS 3801 ET. SEQ. ARE APPLICABLE THERETO.

Signature

Title

Printed Name

Date

***** THIS PAGE WAS INTENTIONALLY LEFT BLANK*****

SMALL AND DISADVANTAGED BUSINESS ENTERPRISE PROGRAM

FAYETTEVILLE PUBLIC WORKS COMMISSION'S SDBE COMPLIANCE PROVISIONS

APPLICATION:

The requirements of Fayetteville Public Works Commission (PWC) Small Disadvantaged Business Enterprise Policy for participation in specific contracts are hereby made part of the Contract Documents. Copies of the Policy may be obtained from:

Fayetteville Public Works Commission
Economic Impact Program
P.O. Box 1089
Fayetteville, North Carolina 28302
Phone (910) 223-4016 Fax (910) 483-1429
E-mail: eiprogram@faypwc.com

NCDOT DBE Directory: www.ebs.nc.gov/VendorDirectory

HUB Directory: <https://ncadmin.nc.gov/businesses/hub>

SDBE Compliance Requirements:

1. The Bidder shall provide, with their Bid Form, at the time bids are due, the documents set forth below, properly executed. Returning executed copies indicates and establishes that the Bidder understands and agrees to any incorporated SDBE contract provisions.
2. All Bidders must provide, with their Bid Form, at the time bids are due, a properly completed and executed copy of **either:**
 - Affidavit A – Listing of Good-Faith Efforts **OR**
 - Affidavit B – Intent to Self-Perform with Own Workforce.¹

Note: Affidavit B should **only** be used if the Contractor will perform **ALL Elements** of the Work on this project with their own forces **AND** will complete **ALL Elements** of this project **WITHOUT** the use of subcontractors, material suppliers, or providers of professional services.
3. Upon being identified as the apparent lowest responsive, responsible Bidder, a Bidder shall, within twenty-four (24) hours of PWC's notification provide a properly completed and executed copy of **either:**
 - Affidavit C – Percentage of SDBE Participation **OR**
 - Affidavit D – Good-Faith Efforts.
4. All Bidders must provide with their Bid Form, at the time bids are due, a properly completed and executed copy of Affidavit E- Identification of SDBE/Local Participation Form

SMALL AND DISADVANTAGED BUSINESS ENTERPRISE PROGRAM

All written statements, certifications, or intentions made by the Bidder shall become a part of the agreement between the Contractor and Fayetteville Public Works Commission for performance of this contract.

SUBCONTRACTOR PAYMENT REQUIREMENTS:

North Carolina General Statutes (N.C.G.S.) 143-134.1 states that the percentage of retainage on payments made by the prime contractor to the subcontractor shall not exceed the percentage of retainage on payments made by the Fayetteville Public Works Commission to the prime contractor. Failure to comply with this provision shall be considered a breach of the contract, and the contract may be terminated in accordance with the termination provisions of the contract.

The Contractor shall provide an itemized statement of payments to each SDBE subcontractor before final payment is processed.

The Contractor shall provide an itemized statement of payments to each NON-SDBE subcontractor before final payment is processed.

Contractor

Signature

Printed Name

Title

Date

SMALL AND DISADVANTAGED BUSINESS ENTERPRISE PROGRAM

Affidavit A: Listing of the Good Faith Efforts

Affidavit of _____
 (Name of Bidder)

I have made a good faith effort to comply under the following areas checked:

Total Available GFE Points: 155		Expected Number GFE Points Required: 50
Points		
10		Contacting small-disadvantaged businesses (SDBE) that reasonably could have been expected to submit a quote and that were known to the contractor or available on Federal, State, or local government-maintained lists at least 10 days before the bid or proposal date, and notifying them of the nature and scope of the work to be performed.
10		Making the construction plans, scope of work, specifications, or requirements available for review by prospective SDBE or providing these documents to them at least 10 days before the bid or proposals are due.
15		Breaking down or combining elements of work into economically feasible units to facilitate SDBE participation.
10		Working with SDBE trade, community, or contractor organizations identified by the U.S. Small Business Administration, N.C. Office for Historically Underutilized Businesses, or N.C. Department of Transportation, and included in the bid documents that provide assistance in the recruitment of small, disadvantaged businesses.
10		Attending any pre-bid meetings scheduled by the public owner.
20		Providing assistance in getting required bonding or insurance, or providing alternatives to bonding or insurance for subcontractors.
15		Negotiating in good faith with interested SDBEs and not rejecting them as unqualified without sound reasons based on their capabilities. Any rejection of an SDBE based on a lack of qualification should have the reasons documented in writing.
25		Providing assistance to an otherwise qualified SDBEs in need of equipment, loan capital, lines of credit, or joint pay agreements to secure loans, supplies, or letters of credit, including waiving credit that is ordinarily required. Assisting SDBEs in obtaining the same unit pricing with the bidder's suppliers in order to help SDBEs in establishing credit.
20		Negotiating joint venture and partnership arrangements with small, disadvantaged businesses to increase opportunities for SDBE participation on a public construction or repair project when possible.
20		Providing quick pay agreements and policies to enable SDBE contractors and suppliers to meet cash-flow demands.
Total GFE Points (Claimed by Bidder):		Total GFE Points (Assessed by PWC):

In accordance with PWC's SDBE Policy and Program Plan, the undersigned will enter into a formal agreement with the firms listed in the Identification of Small Disadvantaged Business Participation schedule, conditional upon execution of a contract with the Owner. Failure to abide by any applicable statutory provision may constitute a breach of the contract. The undersigned hereby certifies that he or she has read the terms of the SDBE business commitment and is authorized to bind the Bidder to the commitment herein set forth.

Date: _____ Name of Authorized Officer: _____

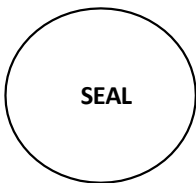

State of North Carolina, County of _____

Subscribed and sworn to before me this _____ day of 20__

Notary Public _____

My commission expires _____

SMALL AND DISADVANTAGED BUSINESS ENTERPRISE PROGRAM

Affidavit B: Intent to Perform Contract with Own Workforce

Affidavit of _____
(Name of Bidder)

I hereby certify that it is our intent to perform 100% of the work required for the contract:

(Name of Project)

In making this certification, the Bidder states that the Bidder does not customarily subcontract elements of this type project, and normally performs and has the capability to perform and will perform **all elements of the work** on this project with his/her own current workforces; and will complete all elements of this project **without** the use of subcontractors, material suppliers, or providers of professional services.

The Bidder agrees to provide any additional information or documentation requested by the Owner in support of the above statement.

The undersigned hereby certifies that he or she has read this certification and is authorized to bind the Bidder to the commitments herein contained.

Date: _____ Name of Authorized Officer: _____

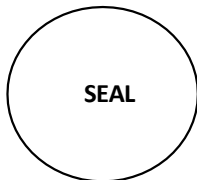

State of North Carolina, County of _____

Subscribed and sworn to before me this _____ day of 20__

Notary Public _____

My commission expires _____

SMALL AND DISADVANTAGED BUSINESS ENTERPRISE PROGRAM

Affidavit C: Percentage of SDBE Participation

Affidavit of _____
(Name of Bidder)

I hereby certify that on contract: _____
(Name of Project)

\$ _____
(Dollar Amount of Total Bid)

I will expend a minimum of _____% of the total dollar amount of the contract with Small Disadvantaged Business Enterprises (SDBE). SDBEs will be employed as subcontractors, vendors, or providers of professional services. Such work will be subcontracted to the following firms listed below.

<u>Name, Address, & Phone No.</u>	<u>*SDBE/Certifying Agency</u>	<u>NAICS</u>	<u>Dollar Value</u>	<u>% of Contract</u>

*SDBE categories: Black-African Americans (B), Hispanic-Americans (H), Asian- Americans (A), Native-Americans (I), Women (F), Socially/Economically Disadvantaged (D), Small (S)
 *Certifying Agencies: NC DOA (HUB), NC DOT (DBE), U.S. SBA

SMALL AND DISADVANTAGED BUSINESS ENTERPRISE PROGRAM

Pursuant to NCGS 143-128.2(d), the undersigned will enter into a formal agreement with SDBEs for work listed in this schedule, conditional upon execution of a contract with the Owner. Failure to fulfill this commitment may constitute a breach of the contract.

The undersigned hereby certifies that he or she has read the terms of this commitment and is authorized to bind the Bidder to the commitment herein set forth.

Date: _____ Name of Authorized Officer: _____



State of North Carolina, County of _____

Subscribed and sworn to before me this _____ day of 20__

Notary Public _____

My commission expires _____

SMALL AND DISADVANTAGED BUSINESS ENTERPRISE PROGRAM

Affidavit D: Good Faith Efforts

If the Owner determines, using reasonable discretion, that Affidavit C is insufficient, Bidder agrees to provide the following information regarding any good-faith efforts.

<u>Name, Address, & Phone No.</u>	<u>*SDBE Category</u>	<u>NAICS</u>	<u>Dollar Value</u>

*SDBE categories: Black-African Americans (B), Hispanic-Americans (H), Asian- Americans (A), Native-Americans (I), Women (F), Socially/Economically Disadvantaged (D)

Bidder may be requested to provide documentation of the Bidder’s good-faith efforts. Examples of documentation may include the following:

- a. Copies of solicitations for quotes to SDBEs. Each solicitation may include a specific description of the work to be subcontracted, the location where bid documents can be reviewed, the representative of the Prime Bidder to contact, and the location, date, and time when quotes must be received.
- b. Copies of quotes or responses received from each firm responding to the solicitation.
- c. A telephone log of follow-up calls to each firm sent a solicitation.
- d. For subcontracts where an SDBE is not considered the lowest responsible sub-bidder, copies of quotes received from all firms submitting quotes for that particular subcontract.
- e. Documentation of any contacts or correspondence to SDBE, community or contractor organizations in an attempt to meet the goal.
- f. Copy of pre-bid roster.
- g. Letter documenting efforts to provide assistance in obtaining required bonding or insurance for SDBEs.
- h. Letter detailing reasons for rejection of an SDBE due to lack of qualification.
- i. Letter documenting proposed assistance offered to SDBEs in need of equipment, loan capital, lines of credit, or joint pay agreements to secure loans, supplies, or letters of credit, including waiving credit that is ordinarily required.

Failure to provide the documentation listed in these provisions may result in rejection of the bid and award to the next lowest responsible and responsive Bidder.

Date: _____ Name of Authorized Officer: _____

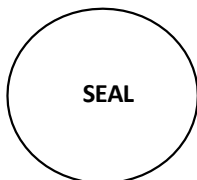

State of North Carolina, County of _____
 Subscribed and sworn to before me this _____ day of 20____
 Notary Public _____
 My commission expires _____

SMALL AND DISADVANTAGED BUSINESS ENTERPRISE PROGRAM

Affidavit E: Identification of SDBE/Local Participation

_____ (Name of Bidder)

I hereby certify that on contract: _____

(Name of Project)

We will use the following Small Disadvantaged Business Enterprises (SDBE), and Local (Cumberland, Hoke, Harnett County) as construction subcontractors, vendors, suppliers, or providers of professional or general services.

<u>Name, Address, & Phone No.</u>	<u>*SDBE Category / **Local</u>	<u>NAICS</u>	<u>Dollar Value</u>

*SDBE categories: Black-African Americans (B), Hispanic-Americans (H), Asian- Americans (A), Native-Americans (I), Women (F), Socially/Economically Disadvantaged (D)

**Local: Fayetteville Metropolitan Statistical Area (MSA) comprising Cumberland County, Hoke County, and Harnett County. PWC is requesting this information for reporting purposes only, and the use of local entities will not be considered for compliance with the requirements of the SDBE Policy.

The total value of SDBE/local business contracting will be \$ _____

Date: _____ Name of Authorized Officer: _____

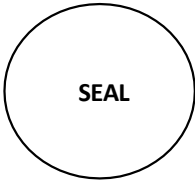

State of North Carolina, County of _____
 Subscribed and sworn to before me this _____ day of 20____
 Notary Public _____
 My commission expires _____

SMALL AND DISADVANTAGED BUSINESS ENTERPRISE PROGRAM

**FAYETTEVILLE PUBLIC WORKS COMMISSION
SDBE ADD / CHANGE FORM**

If a SDBE subcontractor fails to complete work under the subcontract for any reason, the recipient must require the prime contractor to employ the good faith efforts set forth in the SDBE Policy if soliciting a replacement or additional subcontractor.

For SDBE Change Request, please provide all information below:

Prime Contractor: _____

Subcontracted Work: _____

Previous Subcontractor: _____

Reason this for change request:

New Subcontractor: _____ SDBE Category: _____

To Add SDBE Subcontractor/Subcontracted work:

If this is a new trade being subcontracted or a subcontractor that was not documented in the original Project Bid Information submittal, then good faith efforts to solicit an SDBE must be documented, as the original SDBE instructions indicate. Please provide all good faith efforts below showing all the SDBE firms contacted to perform this work, along with any additional good faith efforts or evidence that there are not reasonably available firms in the work area. PWC's SDBE Policy requires that good faith efforts are to be carried out to the fullest extent practicable. If solicitations were not carried out due to being impracticable, please attach this explanation to this form.

Name, Address, & Contact Information	SBE or DBE and Certifying agency	How was this firm contacted (email, letter, or Phone), and what was the result of the solicitation? *

*Must submit copies of emails or letters. If phone calls were made, this sheet can serve as documentation of calls

Date: _____ Name of Authorized Officer: _____

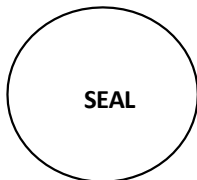

State of North Carolina, County of _____

Subscribed and sworn to before me this _____ day of 20__

Notary Public _____

My commission expires _____

SMALL AND DISADVANTAGED BUSINESS (SDBE), SMALL LOCAL SUPPLIER (SLS), AND LOCAL BUSINESS DISCLOSURE FORM

Prime Contractor: _____
 Address & Phone: _____
 Project: _____
 Name: _____
 Pay Application # _____

Please complete the form below by providing the necessary information for the payments made to each subcontractor, vendor, or supplier for the work associated with the identified contractor application for payment. This form must be fully completed and attached to each contractor application for payment.

Firm Name	SDBE, SLS, or Local	Construction Trade or Supplies	Payment Amount
<i>Ex. ABC Company</i>	<i>SDBE – NC HUB M</i>	<i>Hauling</i>	<i>\$25,000.00</i>
<i>Ex. DEF Enterprise</i>	<i>SLS – PWC</i>	<i>Paint</i>	<i>\$600.00</i>
<i>Ex. GHI Incorporated</i>	<i>Local – Fayetteville</i>	<i>Tire Repair</i>	<i>\$2,000.00</i>

Signature

Printed Name

Title

Date

SECTION B - CONTRACT EXECUTION DOCUMENTS

***** THIS PAGE WAS INTENTIONALLY LEFT BLANK *****

NOTICE OF AWARD

TO: _____

PROJECT DESCRIPTION: PWC2526102 - LIFT STATION 33 CARGILL LIFT STATION STRUCTURAL REPAIR

The OWNER has considered the BID submitted by you for the above described work in response to its Advertisement for Bids dated _____ and Instructions to Bidders.

You are hereby notified that your BID has been accepted for items in the amount of \$_____.

You are required by the Instructions to Bidders to execute the Agreement and furnish the required Performance Bond, Payment Bond, and Certificates of Insurance within ten (10) calendar days from the date of this NOTICE to you.

If you fail to execute said Agreement and to furnish said Bonds within ten (10) days from the date of this Notice, said Owner will be entitled to consider all your rights arising out of the OWNER's acceptance of your BID as abandoned and as a forfeiture of your Bid Bond. The Owner will be entitled to such other rights as may be granted by law.

You are required to return an acknowledged copy of this NOTICE OF AWARD to the OWNER.

Dated this _____ day of _____, 2026.

**OWNER: FAYETTEVILLE PUBLIC WORKS COMMISSION
FAYETTEVILLE, NC**

**BY: Nikole Bohannon
TITLE: Procurement Manager**

ACCEPTANCE OF AWARD

PWC2526102 - LIFT STATION 33 CARGILL LIFT STATION STRUCTURAL REPAIR

Receipt of the preceding NOTICE OF AWARD is hereby acknowledged this the _____
day of _____, 2026.

(CONTRACTOR)

By: _____

Title: _____

- END OF SECTION -

State of North Carolina
Cumberland County

CONSTRUCTION AGREEMENT

THIS CONSTRUCTION AGREEMENT (“Agreement” or “Contract”) is made by and between the Fayetteville Public Works Commission (“PWC”), a North Carolina public authority, and [REDACTED] [PER THE CHARTER (SEE SEC 6A.20), THE CONSTRUCTION CONTRACT, IF MORE THAN \$500K, MUST BE BETWEEN THE CITY (BY AND THROUGH PWC) AND THE CONTRACTOR], (“Contractor”), a [REDACTED] registered to do business in North Carolina (each of PWC and Contractor is a “Party” and both are collectively the “Parties”) as of the date of execution last written below (the “Effective Date”). The Parties agree as follows:

1. The Construction Project. Contractor shall furnish and bear solely the entire cost of all labor and materials necessary for the construction and/or renovation of the Project (defined hereinbelow) as specified in the Contract Documents (defined hereinbelow) and complete all Work on the Project in a Workmanlike manner in strict accordance with the Contract Documents, schedule delivery of the new materials, furnish and bear solely the entire cost of all supervision, contract administration, equipment, tools, and other means necessary to complete the Project, perform every obligation imposed by the Contract Documents, and be solely responsible for the clean-up and disposal of all materials and debris relating to or arising from the construction and renovation, subject to any exceptions that are specifically set forth in the Contract Documents. Except as otherwise specifically provided in the Contract Documents, Contractor is solely responsible for all construction means, methods, techniques, sequences, procedures, safety precautions or programs, supervising, coordinating, and performing all the Work necessary to complete the Project; provided, however, PWC shall have the right, without incurring any liability to the Contractor, to suspend Contractor’s performance when a PWC employee, in his or her opinion, observes a safety violation involving a threat to life or imminent danger of bodily injury, and the suspension shall remain in effect until Contractor remedies the safety violation.

2. Terms. Capitalized terms used in this Agreement have the meaning specified below:

“Business Day” means each calendar day that is not a Saturday, Sunday, holiday observed by the federal government for its employees, or holiday observed by the State of North Carolina for its employees.

“Completion of the Project” means: (i) the Project is completed in accordance with this Agreement, except for punch list items; (ii) PWC has received any required temporary or final certificate of occupancy from the governmental agency with jurisdiction over the Project; and (iii) the registered architects or engineers (the “Designer(s)”) who designed portions or components of the Project have issued certificates of Completion of the Project as to those portions or components.

“Contract Documents” means the following documents that were either made available to Contractor by PWC during the bid solicitation process (including Drawings) or executed by the Parties or both, which are all incorporated by reference herein:

- a. This Agreement
- b. General Conditions
- c. Bid Submittal Documents
- d. Contractor's Submitted Bid
- e. Bid Bond
- f. [Form of Exceptions]
- g. Notice of Award
- h. Acceptance of Award
- i. Performance Bond
- j. Payment Bond
- k. Copy of General Contractor's License
- l. Power of Attorney
- m. Certificate of Insurance
- n. Section C – Administrative Provisions
- o. Section D - Technical Specifications
- p. [Additional Specifications]
- q. [Appendices]

The following documents may be delivered or issued on or after the Effective Date of the Agreement and may not be attached to this Agreement, but are considered Contract Documents when executed by the Parties:

- r. Notice to Proceed and Acceptance of Notice
- s. Work Change Directive(s)
- t. Change Order(s)
- u. Field Order(s)

There are no Contract Documents other than those identified in this Agreement. The Contract Documents may only be amended, modified, or supplemented as provided in this Agreement in a writing signed by the Parties.

"Fault" means a breach of contract by Contractor, negligent, reckless, or intentional act(s) or omission(s) constituting a tort under applicable statutes or common law by one or more Responsible Persons, or violation(s) of applicable statute(s) or regulation(s) by a Responsible Person.

"Project" means _____, as more specifically set forth in the Contract Documents.

"Responsible Person" means the Contractor and each of its employees, agents, representatives, subcontractors, or other persons and entities for which Contractor may be liable or responsible as a result of any statutory, tort, or contractual duty.

The terms used in this Agreement shall have the meaning as stated herein and in the General Conditions. In the event of a conflict between the terms of this Agreement and any other component(s) of the Contract Documents, the terms of this Agreement shall govern.

3. Contract Price. PWC shall pay Contractor for Completion of the Project in accordance with the Contract Documents the amount identified in the accepted Bid Form of

Contractor, being in the total amount of \$ [REDACTED] (the "Price"). Contractor understands and acknowledges that the Price is derived from a specific appropriation of funds provided for the Project. Contractor agrees and acknowledges the Price is equal to the aggregate cost of all Work to be done on the Project, including all labor, materials, equipment, apparatus, and supplies, set in accordance with the amount specified on the Bid Form submitted by Contractor and accepted by PWC.

4. Contract Times. The Parties shall perform their obligations under this Agreement in compliance with all scheduling deadlines set forth in the Contract Documents. The Contractor shall commence the Work to be performed under this Agreement on a date to be specified in accordance with the Notice to Proceed issued by PWC. Contractor shall achieve Completion of the Project no later than **360 consecutive calendar days** from said date plus any modifications thereof allowed in accordance with the Contract Documents (the "Completion Date").

5. Payment. PWC shall pay Contractor in installment payments plus a final payment, as set forth in the Contract Documents. For each applicable installment payment, Contractor shall submit an application for payment in accordance with the Contract Documents. An application for payment will be processed by PWC as provided in the Contract Documents. Such installment payments shall reflect the actual Cost of the Work, not to exceed in total the Price, and the allocable portion of the total Price for said installment. PWC shall make payment to the Contractor, less any applicable retainage set forth in the Contract Documents; provided, however, that PWC may withhold all or a portion of a payment on account of (1) incomplete Work, (2) defective or nonconforming Work, (3) claims filed or a reasonable basis to believe that such claims will be filed imminently, (4) failure of the Contractor to make payments properly for labor, services, materials, equipment or subcontracts, (5) damages caused to PWC or another party by one or more Responsible Persons, or (6) failure to comply with the terms and conditions of this Agreement. In the final payment, PWC shall pay the balance of the Price, including all retained amounts, less any Liquidated Damages and other applicable damage and claim amounts, to Contractor within forty-five (45) days of Completion of the Project; provided, however, that PWC may withhold a reasonable sum from the final payment to ensure correction of any final items or condition on the Project.

6. Retainage. Subject to any restrictions applicable to any federal grant funds that may be utilized for the Project, PWC may, in its discretion, retain up to five percent (5%) of any periodic payment due Contractor; provided, however, when the Project is fifty percent (50%) complete, PWC, with written consent of the surety, shall not retain any further retainage from periodic payments due Contractor if Contractor continues to perform satisfactorily and any nonconforming Work identified in writing prior to that time by PWC or the Designer has been corrected by Contractor and accepted by PWC or the Designer, and provided further that full payment, less authorized deductions, shall also be made for those line item trades that have reached one hundred percent (100%) completion of their contract obligations by or before the Project is fifty percent (50%) complete if Contractor has performed satisfactorily in accordance with G.S. 143-134.1(b2), contingent upon PWC's receipt of an approval or certification from the Designer that the Work performed by the subcontractor is acceptable and in accordance with the Contract Documents. If PWC determines Contractor's performance is unsatisfactory, PWC may, in its discretion, reinstate retainage for each subsequent periodic application for payment as authorized in this Section up to the maximum amount of five percent (5%). The Project shall be deemed fifty percent (50%) complete when Contractor's gross project invoices, excluding the value of materials stored off-site, equal or exceed fifty percent (50%) of the Price, except the value of materials stored on-site shall not exceed twenty percent (20%) of Contractor's gross project invoices for the purpose of determining whether the Project is fifty percent (50%)

complete. Within 60 days after the submission of a pay request and one of the following occurs, as specified in the Contract Documents, PWC, with written consent of the surety, shall release to Contractor all retainage on payments held by PWC: (i) PWC receives a certificate of Substantial Completion from the Designer in charge of the Project; or (ii) PWC receives beneficial occupancy or use of the Project; provided, however, PWC may in its discretion retain sufficient funds to secure Completion of the Project or corrections on any Work. If PWC retains funds, the amount retained shall not exceed two and one-half times the estimated value of the Work to be completed or corrected. Any reduction in the amount of the retainage on payments shall be with the consent of Contractor's surety. The existence of any third-party claims against Contractor or any additive change orders to the Construction Documents shall not be a basis for delaying the release of any retainage on payments. Notwithstanding anything in this Section to the contrary, following fifty percent (50%) completion of the Project, PWC shall be authorized to withhold additional retainage from a subsequent periodic payment, not to exceed five percent (5%), in order to allow PWC to retain two and one-half percent (2.5%) total retainage through the Completion of the Project. In the event that PWC elects to withhold additional retainage on any periodic payment subsequent to release of retainage on a line-item of Work pursuant to G.S. 143-134.1(b2), Contractor may also withhold from the subcontractors remaining on the project sufficient retainage to offset the additional retainage held by PWC, notwithstanding the actual percentage of retainage withheld by PWC of the Project as a whole. Neither PWC's nor Contractor's release of retainage on payments as part of a payment in full on a line-item of Work pursuant to G.S. 143-134.1(b2) shall affect any applicable warranties on Work done by Contractor or subcontractor, and the warranties shall not begin to run any earlier than either PWC's receipt of a certificate of Substantial Completion from the Designer in charge of the Project or PWC receives beneficial occupancy.

7. Liquidated Damages. Time is of the essence with respect to performance of each of the Parties' obligations under this Agreement. Contractor recognizes and acknowledges that PWC will suffer financial and other losses if the Project is not completed by the Completion Date. The Parties recognize and agree that the delays, expense, and difficulties involved in proving in a legal or arbitration proceeding the actual loss suffered by PWC if the Project is not completed by the Completion Date. Accordingly, instead of requiring any such proof, Contractor and PWC agree that in the event Contractor fails to achieve Completion of the Project by the Completion Date, Contractor shall pay to PWC as liquidated damages to compensate PWC for damages related to the delayed Completion of the Project one thousand dollars (\$1000.00) per day ("Liquidated Damages") for each calendar day Contractor fails to achieve Completion of the Project by the Completion Date.

8. Contractor's Representations and Warranties. In order to induce PWC to enter into this Agreement, Contractor makes the following representations and warranties to PWC:

a. Contractor is duly licensed in the State of North Carolina to complete all Work necessary for the Project, is duly organized, validly existing and in good standing and has all requisite powers, rights, and authority to execute, enter into, and perform this Agreement in accordance with the terms and conditions of this Agreement, and this Agreement constitutes a legal, valid, and binding obligation of Contractor enforceable against it in accordance with its terms.

b. Contractor has read the Contract Documents, and acknowledges and understands all data, materials, specifications, and requirements identified in the Contract Documents.

c. Contractor has visited the site for the Project, conducted a thorough, visual examination of the site and adjacent areas, and become familiar with and is satisfied as to the general, local, and site conditions that may affect cost, progress, and performance in completing the Project. Contractor is familiar with and is satisfied as to all laws and regulations that may affect cost, progress, and performance to complete the Project.

d. Contractor has carefully studied all: (1) reports of explorations and tests of subsurface conditions at or adjacent to the site and all drawings of physical conditions relating to existing surface or subsurface structures at the site that have been identified in the Contract Documents and any accompanying reports and drawings, and (2) reports and drawings relating to hazardous environmental conditions, if any, at or adjacent to the site that have been identified in the Contract Documents and any accompanying reports and drawings.

e. Contractor has considered the information known to Contractor itself; information commonly known to contractors doing business in the locality of the Site; information and observations obtained from visits to the Site; the Contract Documents; and the Site-related reports and drawings identified in the Contract Documents, if any, with respect to the effect of such information, observations, and documents on (1) the cost, progress, and performance of the Work; (2) the means, methods, techniques, sequences, and procedures of construction to be employed by Contractor; and (3) Contractor's safety precautions and programs.

f. Based on the information and observations referred to in subsection e. of this Section, Contractor agrees that no further examinations, investigations, explorations, tests, studies, or data are necessary for the performance of the Work at the Price commencing on the commencement date and in accordance with the other terms and conditions of the Contract.

g. Contractor is aware of the general nature of Work to be performed by PWC and others at the Site that relates to the Work as indicated in the Contract Documents.

h. Contractor has given PWC's Designer written notice of all conflicts, errors, ambiguities, or discrepancies that Contractor has discovered in the Contract Documents, and the written resolution thereof by the Designer is acceptable to Contractor.

i. The Contract Documents are generally sufficient to indicate and convey understanding of all terms and conditions for performance and furnishing of the Work.

j. Contractor's entry into this Agreement constitutes an incontrovertible representation by Contractor that, without exception, all prices in the Agreement are premised upon performing and furnishing the Work required by the Contract Documents.

k. Contractor has no business or personal relationship with any PWC Commissioner, officer, director, manager, or supervisor and Contractor covenants to disclose immediately to PWC any such relationship that develops

during the performance of Work on the Project.

9. Contractor's Payment Obligations. Contractor shall pay all of its obligations arising out of or in connection with the Project in a timely manner to all persons supplying materials in the prosecution of the Work and to all laborers and others employed thereon.

10. Performance and Payment Bonds. Contractor shall obtain and deliver to PWC a performance bond in the amount of one hundred percent (100%) of the Price, conditioned upon the faithful performance of the Project and all Work in accordance with the Contract Documents, which bond shall be solely for the protection of PWC. Contractor shall obtain and deliver to PWC a payment bond in the amount of one hundred percent (100%) of the Price, conditioned upon the prompt payment for all labor or materials for which the Contractor or one or more of its subcontractors is liable, which payment bond shall be solely for the protection of the persons furnishing materials or performing labor for which the Contractor is liable. The performance bond and the payment bond shall be executed by one or more surety companies legally authorized to do business in the State of North Carolina, shall become effective upon the awarding of the construction contract by PWC to Contractor, and shall at all times comply with the requirements set forth in Article 3 of North Carolina General Statutes Chapter 44A. In the event PWC deems the surety or sureties upon any bond necessary for this Agreement and the completion of the Project, or if for any reason, such bond ceases to be adequate to cover the performance and/or payment of the Work, Contractor shall, at its expense, within five (5) days after the receipt of notice from PWC, furnish an additional bond or bonds in such form and amount, and with such surety or sureties as shall be satisfactory to PWC. In such event no further payment to Contractor shall be deemed to be due under this Agreement until new or additional security for the performance and payment of the Project shall be furnished in manner and form satisfactory to PWC. Contractor understands and acknowledges that PWC, as a public authority, is not subject to the provisions of Articles 1 and 2 of Chapter 44A of the General Statutes, in accordance with G.S. 44A-34 and applicable law.

11. Contractor's Damage Repair Obligations. Contractor shall be responsible for all damages to the property of the City of Fayetteville and of PWC that may result from the normal procedure of a Responsible Person's actions in the prosecution of the Work or that may be caused by or result from the negligence of a Responsible Person during the progress of or connected with the prosecution of the Work, whether within the limits of the Work or elsewhere. Contractor shall promptly restore all such property so damaged to a condition as good as it was immediately prior to Contractor initiating the Work on the Project.

12. Defective Work. The Project shall be subject to observation and approval by PWC, Designer, and representatives of governmental agencies with jurisdiction over the Project. PWC and Designer shall be entitled to enter at all reasonable times the premises subject to construction or renovation to inspect the Work performed by or on behalf of Contractor, provided that such entry and inspection does not materially interfere with the progress of construction. Contractor shall correct promptly, at no cost to PWC, all Work reasonably rejected by PWC or by its representatives. Should Contractor fail to correct rejected Work, PWC may, acting in its sole discretion, correct such Work and the Contractor shall pay PWC's actual costs of correction and any other applicable amounts identified in the Contract Documents.

13. As-Built Drawings. Contractor shall maintain during the progress of the Project as-built drawings indicating the current status of the Project as actually performed. Upon Completion of the Project, Contractor shall prepare a final version of such as-built drawings and

submit them to PWC for approval.

14. Assignment. This Agreement shall be binding upon and inure to the benefit of the Parties, their legal representatives, successors, and assigns. Contractor may not assign, transfer, convey, or encumber, whether voluntarily or by operation of law, this Agreement or any obligations, rights under, or interests in this Agreement to a third party without the prior written consent of PWC; and, specifically, but without limitation, money that may become due and money that is due may not be assigned without such consent (except to the extent that the effect of this restriction may be limited by law), and unless specifically stated to the contrary in any written consent to an assignment, no assignment will release or discharge the assignor from any duty or responsibility under the Contract Documents.

15. Indemnity. Contractor shall indemnify, defend, and hold harmless PWC and its Commissioners, officers, employees, agents, and representatives and the City of Fayetteville and its elected officials, managers, employees, agents, and representatives and Design Engineer (collectively "Indemnitees") from and against all claims, actions, liabilities, damages, losses, costs, and expenses (including, without limitation, injury to or death of any persons and damage to property, economic and consequential damages and attorneys' fees) asserted by one or more third parties against one or more of the Indemnitees if the Fault of one or more Responsible Persons is a proximate cause of the loss, damage, or expense indemnified. Contractor's obligation to indemnify, defend, and hold harmless the Indemnitees shall survive the termination of this Agreement.

16. Insurance. Contractor shall maintain during the Work and for at least three (3) years following Completion of the Project the insurance coverage set forth in the Contract Documents, which insurance shall be placed with insurance companies authorized to do business in the State of North Carolina and rated A minus VII or better by the current edition of Best's Key Rating Guide or otherwise approved in writing by PWC. Prior to initiating any Work, Contractor shall deliver certificates of insurance confirming each such coverage required by the Contract Documents, and Contractor shall direct its insurers to provide annually to PWC certificates confirming each such coverage during the coverage period. PWC shall be named as an additional insured in the comprehensive automobile and commercial liability insurance policies. Commercial general liability coverage shall be written on an "occurrence" basis. Contractor shall not reduce or allow the required insurance coverages to lapse without PWC's prior written approval. All policies for insurance must be endorsed to contain a provision giving PWC a thirty (30) calendar day prior written notice by certified mail of any cancellation of that policy or material reduction in coverage. Should a notice of cancellation be issued for non-payment of premiums or any part thereof, or should Contractor fail to provide and maintain certificates as set forth herein, PWC shall have the right, but shall not have the obligation, to pay such premium to the insurance company or to obtain such coverage and to deduct such payment from any sums that may be due or become due to Contractor, or to seek reimbursement for said payments from Contractor. Any such sums paid by PWC shall be due and payable immediately by Contractor upon notice from PWC. The insurance provisions of this Agreement shall not be construed as a limitation on Contractor's responsibilities and liabilities pursuant to the terms and conditions of this Agreement. Contractor's obligation to maintain insurance for three (3) years after Completion of the Project shall survive the termination of this Agreement.

17. Warranty. The Contractor hereby grants to PWC a warranty on all materials and Workmanship involved in the Project for a period of one (1) year from the Completion Date and a period of two (2) years from the Completion Date for any latent structural defects. PWC shall

give written notice to Contractor of any claim under this Section within the time specified hereinabove. This warranty shall be in addition to, and not in derogation of, all other rights and privileges which PWC may have under law, equity, or instrument, and shall survive the Completion Date and the final settlement and shall be binding on Contractor notwithstanding any provision in any other writing executed by PWC heretofore or contemporaneous with the execution of the Agreement or prior to the Completion Date.

18. Waiver. No failure on the part of any party to exercise, and no delay in exercising, any right, power, or privilege hereunder shall operate as a waiver thereof, nor shall any single or partial exercise of any right hereunder preclude any other or further cumulative and not exclusive of any remedies provided by law. This Agreement shall be binding upon and inure to the benefit of the parties, their legal representatives, successors, and assigns. This Agreement may not be assigned, transferred, conveyed, or encumbered, whether voluntarily or by operation of law, by either party without the prior written consent of the other party, which consent shall not be unreasonably withheld.

19. Law. THIS AGREEMENT SHALL BE GOVERNED BY AND INTERPRETED AND ENFORCED IN ACCORDANCE WITH THE LAWS OF THE STATE OF NORTH CAROLINA WITHOUT GIVING EFFECT TO THE CHOICE OF LAW PROVISIONS THEREOF. The Contractor shall at all times comply with all applicable Federal, state, and local laws and building codes in the performance of its obligations under the Agreement.

20. Dispute Resolution. In the event of any dispute, controversy, or claim of any kind or nature arising under or in connection with this Agreement (a "Dispute") and involving any two or more of the following parties, PWC, Designer, Contractor or any subcontractor of Contractor, the party initiating the Dispute shall serve written notice of a Dispute on the party(ies) to the dispute, and those parties shall endeavor to settle the dispute first through direct, informal discussions between the parties' selected representatives. Any such representative(s) shall have binding authority to settle the Dispute. In the event the parties do not settle the Dispute within ten (10) days from the date of written notice of the Dispute, any party to the Dispute may, by written notice to the other party(ies), engage a mediator certified under the laws of the State of North Carolina to mediate the Dispute within thirty (30) days of such notice. The parties to the Dispute shall attend mediation in good faith. In the event mediation is unsuccessful, any party to the dispute may initiate arbitration proceedings. Any controversy or claim arising out of or relating to the Contract Documents, or the breach thereof, shall be settled by binding arbitration administered by the American Arbitration Association under its Construction Industry Arbitration Rules, and judgment on the award rendered by the arbitrator(s) may be entered in any court having jurisdiction thereof. All of the foregoing dispute resolution procedures shall be held in Cumberland County, North Carolina. The costs of the mediator and arbitrator in a dispute resolution process shall be divided equally among the parties to the process; provided, however, PWC shall bear at least one-third of the cost if PWC is a party to the dispute resolution and the remainder of the cost shall be divided equally among the other parties participating in the dispute resolution. PWC shall, in its contractual arrangements with Designer, and Contractor shall, in its contracts with subcontractors and they in their contracts with lower-tier subcontractors authorize and direct such parties to participate in the dispute resolution procedures set forth in this Section. Unless otherwise directed in writing by PWC, Contractor shall continue the Project and maintain compliance with the scheduling deadlines set forth in the Contract Documents during any dispute resolution proceedings. If Contractor continues to perform, PWC shall make payments due for the continued performance in accordance with this Agreement. The provisions of this Section shall not extend any applicable statutes of limitation or repose.

21. Execution; Modification; Entire Agreement; Severability. This Agreement may be executed in counterparts with the same effect as if the signatures to each counterpart were upon a single instrument, and all such counterparts together shall be deemed an original of this Agreement. For purposes of this Agreement, a facsimile copy or scanned copy or photocopy of a party's signature shall be sufficient to bind such party. This Agreement shall be subject to execution by electronic means in accordance with Article 40 of Chapter 66 of the North Carolina General Statutes. No oral communication, promise, understanding, or agreement before, contemporaneous with, or after the execution of this Agreement shall affect or modify any of the terms and conditions and obligations of the Contract Documents. The Contract Documents shall be modified only by a subsequent writing signed by both Parties. The Contract Documents shall be conclusively considered to contain and express all the terms and conditions agreed upon by the Parties, notwithstanding any prior or contemporaneous written communication, promise, understanding or agreement. Should any provision of this Agreement or any of the Contract Documents at any time be in conflict with any law, statute, rule, regulation, order, or ruling and thus be unenforceable, or be unenforceable for any other reason, then the remaining provisions of this Agreement shall remain in full force and effect and the court or arbitrator shall give the offending provision the fullest meaning and effect permitted by law. The titles of the Sections throughout this Agreement are for convenience only and the words contained therein shall in no way be held to explain, modify, amplify or aid in the interpretation, construction, or meaning of the provisions of this instrument.

22. Notices. Any notice which either Party is required or desires to give the other hereunder shall be deemed sufficiently given if, in writing, it is delivered personally, or sent by certified U.S. mail, return-receipt requested, postage prepaid, to the addresses listed herein below, or such other address as either Party shall give to the other Party by written notice in accordance herewith. Any notice given herein by personal delivery shall be deemed delivered when received. Any properly addressed notice given herein by certified mail shall be deemed delivered on third Business Day after the same is deposited in an official United States Post Office, postage prepaid, or if sooner upon the date when the return receipt therefore is signed, or refusal to accept the mailing by the addressee is noted thereon by the postal authorities.

To PWC:
Fayetteville Public Works Commission
Attn: Timothy Bryant, CEO/General Manager
PO Box 1089
Fayetteville, NC 28302

To Contractor:

23. Termination. PWC may terminate this Agreement immediately if during the progress of the Work or during the warranty period, the Contractor:

- a. Persistently fails to prosecute the Work properly and in accordance with this contract, including but not limited to include failure to provide sufficient crews, equipment, or resources, or failure to adhere to the schedule;

- b. Demonstrates disregard for the policies, procedures, or requirements of PWC;
- c. Demonstrates complete disregard of the authority of PWC or its designated representatives; or
- d. Violates in any substantial way the provisions and requirements of this Agreement.

Such termination shall be effective upon written notice to Contractor and its surety. PWC may terminate the contract for its convenience by providing Contractor at least seven (7) calendar days prior written notice, in which event Contractor shall be paid for all Work completed, plus other expenses as mutually agreed upon between PWC and Contractor.

24. Compliance. Contractor hereby acknowledges that “E-Verify” is the federal E-Verify program operated by the US Department of Homeland Security and other federal agencies which is used to verify the Work authorization of newly hired employees pursuant to federal law and in accordance with Article 2, Chapter 64 of the North Carolina General Statutes. Contractor further acknowledges that all employers, as defined by Article 2, Chapter 64 of the North Carolina General Statutes, must use E-Verify and after hiring an employee to Work in the United States, shall verify the Work authorization of the employee through E-Verify in accordance with N.C.G.S. §64-26(a). Contractor hereby pledges, attests, and warrants through execution of this Agreement that Contractor complies with the requirements of Article 2, Chapter 64 of the North Carolina General Statutes and further pledges, attests, and warrants that all subcontractors currently employed by or subsequently hired by Contractor shall comply with all E-Verify requirements. Failure to comply with the above requirements shall be considered a breach of this Agreement. Contractor hereby further acknowledges that the execution and delivery of this Agreement constitutes Contractor’s certification to PWC and to the North Carolina State Treasurer that, as of the date of the Effective Date of this Agreement, Contractor is not listed on (a) the Final Divestment List created and maintained by the North Carolina Department of State Treasurer pursuant to the Iran Divestment Act of 2015, Chapter 147, Article 6E of the General Statutes of North Carolina (the “Iran Divestment Act”); or (b) the list of companies that the North Carolina State Treasurer determines to be engaged in a boycott of Israel in accordance with Article 6G of Chapter 147 of the General Statutes of North Carolina. Contractor represents and warrants to Commission that Contractor, and all persons and entities owning (directly or indirectly) an ownership interest in it: (i) are not, and will not become, a person or entity with whom a party is restricted from doing business with under regulations of the Office of Foreign Asset Control (“OFAC”) of the Department of the Treasury (including, but not limited to, those named on OFAC’s Specially Designated and Blocked Persons list) or under any statute, executive order (including, but not limited to, the September 24, 2001, Executive Order 13224 Blocking Property and Prohibiting Transactions with Persons Who Commit, Threaten to Commit, or Support Terrorism), or other governmental action; and (ii) are not knowingly engaged in, and will not knowingly engage in, any dealings or transactions or be otherwise associated with such persons or entities described in clause (i) above. Contractor also shall at all times during the term of this Agreement comply with Executive Order 11246, including but not limited to the Equal Opportunity Clause requirements set forth in 41 C.F.R. § 60-1.4. Contractor shall abide by the requirements of 41 CFR 60–300.5(a) and 60–741.5(a) prohibiting discrimination against qualified individuals on the basis of protected veteran status or disability and requiring affirmative action by covered prime contractors and subcontractors to employ and advance in employment qualified protected veterans and individuals with disabilities.

IN WITNESS WHEREOF, the Parties have executed this Agreement by their duly authorized representatives.

Fayetteville Public Works Commission

CONTRACTOR

**[PER OUR CHARTER (SEE SEC 6A.20),
THE CONSTRUCTION CONTRACT, IF MORE
THAN \$500K, MUST BE BETWEEN THE CITY
(BY AND THROUGH PWC) AND THE CONTRACTOR]**

By: _____
Timothy Bryant, CEO/GM

By: _____

(Printed Name, Title)

Date: _____

Date: _____

This instrument has been preaudited in the manner required by the Local Government Budget and Fiscal Control Act (N.C. Gen. Stat. § 159-1 et seq.).

By: _____
Rhonda Haskins, Chief Financial Officer

Approved as to form:

Legal Dept.

SAMPLE



GENERAL CONDITIONS FOR
FAYETTEVILLE PUBLIC WORKS COMMISSION

General Conditions	5
Article I. Definitions and Terminology	5
Section 1.01 Definitions.....	5
Section 1.02 Terminology.....	10
Article II. Preliminary Matters	11
Section 2.01 Delivery of Bonds and Evidence of Insurance.....	11
Section 2.02 Copies of Documents.....	11
Section 2.03 Before Starting any Work.....	12
Section 2.04 Preconstruction Conference; Designation of Authorized Representatives.....	12
Section 2.05 Initial Acceptance of Schedules.....	12
Section 2.06 Electronic Transmittals.....	13
Article III. Contract Documents: Intent, Requirements, Reuse	13
Section 3.01 Intent.....	13
Section 3.02 Reference Standards.....	13
Section 3.03 Reporting and Resolving Discrepancies.....	14
Section 3.04 Reuse of Documents.....	15
Article IV. Commencement and Progress of the Work	15
Section 4.01 Commencement of Work.....	15
Section 4.02 Reference Points.....	15
Section 4.03 Progress Schedule.....	16
Section 4.04 Delays in Contractor’s Progress.....	16
Article V. Availability of Lands; Subsurface and Physical Conditions; Hazardous Environmental Conditions	16
Section 5.01 Availability of Lands.....	16
Section 5.02 Use of Site and Other Areas.....	17
Section 5.03 Differing Subsurface or Physical Conditions or Underground Facilities.....	17
Section 5.04 Underground Utilities.....	19
Section 5.05 Hazardous Environmental Conditions at Site.....	21
Article VI. Bonds and Insurance	21
Section 6.01 Performance and Payment Bonds.....	21
Section 6.02 Insurance.....	22
Article VII. Contractor’s Responsibilities	23
Section 7.01 Supervision and Superintendence.....	23
Section 7.02 Labor; Working Hours.....	24
Section 7.03 Services, Materials, and Equipment.....	25
Section 7.04 “Or Equals”.....	25
Section 7.05 Concerning Subcontractors, Suppliers, and Others.....	26
Section 7.06 Patent Fees and Royalties.....	27

General Conditions (Rev 7/11/2023)

Section 7.07	Permits	27
Section 7.08	Taxes	27
Section 7.09	Laws and Regulations	27
Section 7.10	Record Documents	28
Section 7.11	Safety and Protection	28
Section 7.12	Emergencies.....	29
Section 7.13	Shop Drawings, Samples, and Other Submittals	29
Section 7.14	Contractor's General Warranty and Guarantee.....	31
Section 7.15	Indemnification	32
Section 7.16	Claims Procedure	32
Section 7.17	Delegation of Professional Design Services	33
Article VIII.	PWC's Responsibilities	34
Article IX.	Amending the Contract Documents; Changes in the Work.....	34
Section 9.01	Amending and Supplementing Contract Documents.....	34
Section 9.02	PWC-Authorized Changes in the Work.....	35
Section 9.03	Unauthorized Changes in the Work	35
Section 9.04	Change of Contract Price.....	35
Section 9.05	Change of Contract Times	36
Section 9.06	Change Proposals	36
Section 9.07	Execution of Change Orders.....	37
Section 9.08	Notification to Surety.....	37
Article X.	Tests, Inspections, and Approvals; Correction, Removal, or Acceptance of Defective Work.....	37
Section 10.01	Access to Work.....	37
Section 10.02	Tests, Inspections, and Approvals	37
Section 10.03	Defective Work	38
Section 10.04	Acceptance of Defective Work.....	39
Section 10.05	Uncovering Work	39
Section 10.06	PWC May Stop the Work.....	40
Section 10.07	PWC May Correct Defective Work.....	40
Article XI.	Claims.....	40
Section 11.01	Claims Process.....	40
Section 11.02	Submittal of Claim	41
Section 11.03	Review and Resolution	41
Section 11.04	Dispute Resolution.....	41
Article XII.	Payments to Contractor; Set-Offs; Completion; Correction Period.....	42
Section 12.01	Progress Payments	42
Section 12.02	Substantial Completion.....	44

General Conditions (Rev 7/11/2023)

Section 12.03	Partial Use or Occupancy	45
Section 12.04	Final Inspection	46
Section 12.05	Final Payment.....	46
Section 12.06	Waiver of Claims	47
Section 12.07	Correction Period.....	47
Article XIII.	Suspension of Work and Termination	48
Section 13.01	PWC May Suspend Work	48
Section 13.02	PWC May Terminate for Cause	48
Section 13.03	PWC May Terminate For Convenience.....	49
Section 13.04	Contractor May Stop Work or Terminate.....	49
Section 13.05	Morality.....	50
Article XIV.	Miscellaneous	50
Section 14.01	Additional General Terms and Conditions.....	50
Section 14.02	Giving Notice	50
Section 14.03	Computation of Times.....	50
Section 14.04	Cumulative Remedies.....	50
Section 14.05	Limitation of Damages	51
Section 14.06	No Waiver.....	51
Section 14.07	Survival of Obligations	51
Section 14.08	Controlling Law	51
Section 14.09	Headings	51

General Conditions

Article I. Definitions and Terminology

Section 1.01 Definitions

Capitalized terms used in the Bid Documents or Contract Documents, including the singular and plural forms, shall have the meaning indicated in the definitions below. In addition to terms specifically defined below, terms with initial capital letters in the Contract Documents include references to identified articles and paragraphs, and the titles of other documents or forms.

- (a) **Addenda**—Written or graphic instruments issued before the opening of Bids which clarify, correct, or change the Bid Documents or other Contract Documents.
- (b) **Agreement**—The written instrument, executed by PWC and Contractor, that sets forth the Contract Price and Contract Times, identifies the parties, designates the specific documents that encompass the Contract Documents, and provides other material provisions that govern the relationship between the parties as it relates to the Project. The Agreement is also referred to, and titled as, the “Construction Agreement.”
- (c) **Application for Payment**—The form that Contractor shall use during the Work in requesting progress or final payments. Any Application for Payment shall be accompanied by such supporting documentation as is required by the Contract Documents.
- (d) **Bid**—The offer of a Bidder submitted on the prescribed form setting forth the prices for the Work to be performed.
- (e) **Bidder**—An individual or entity that submits a Bid to PWC for the Project.
- (f) **Bid Documents**—The Bidding Requirements, the proposed Contract Documents, and all Addenda.
- (g) **Bidding Requirements**—The Invitation to Bid, Instructions to Bidders, Bid Bond or other Bid security, if any, the Bid Form, and the Bidder’s original Bid with any requisite attachments.
- (h) **Business Day**—each calendar day that is not a Saturday, Sunday, or holiday observed by PWC (New Year’s Day, Martin Luther King, Jr. Day, Good Friday, Memorial Day, Independence Day, Labor Day, Veteran’s Day, Thanksgiving Day (and the day after), and Christmas (2 days) for its employees.
- (i) **Change Order**—A document that is signed by Contractor and PWC, which authorizes an addition, deletion, or revision in the Work, an adjustment in the Contract Price or the Contract Times, a change in the scope of the Project, or other revision to the Agreement, issued on or after the Effective Date of the Agreement.
- (j) **Change Proposal**—A written request by Contractor, submitted in compliance with the procedural requirements set forth in the Contract Documents, seeking an adjustment in Contract Price or Contract Times, or both; contesting an initial decision by PWC concerning the requirements of the Contract Documents or the acceptability of Work under the Contract Documents; challenging a set-off against payments due; or seeking other relief with respect to the terms of the Agreement.

- (k) Completion of the Project—Has the meaning as set forth in the Construction Agreement.
- (l) Constituent of Concern—Asbestos, petroleum, radioactive materials, polychlorinated biphenyls (PCBs), hazardous waste, and any substance, product, waste, or other material of any nature whatsoever that is or becomes listed, regulated, or addressed pursuant to (a) the Comprehensive Environmental Response, Compensation and Liability Act, 42 U.S.C. §§9601 et seq. (“CERCLA”); (b) the Hazardous Materials Transportation Act, 49 U.S.C. §§5101 et seq.; (c) the Resource Conservation and Recovery Act, 42 U.S.C. §§6901 et seq. (“RCRA”); (d) the Toxic Substances Control Act, 15 U.S.C. §§2601 et seq.; (e) the Clean Water Act, 33 U.S.C. §§1251 et seq.; (f) the Clean Air Act, 42 U.S.C. §§7401 et seq.; or (g) any other federal, state, or local statute, law, rule, regulation, ordinance, resolution, code, order, or decree regulating, relating to, or imposing liability or standards of conduct concerning, any hazardous, toxic, or dangerous waste, substance, or material.
- (m) Contract Price—The money that PWC has agreed to pay Contractor for Completion of the Project in accordance with the Contract Documents. May also be referred to as “Price” throughout the Contract Documents.
- (n) Contract Times—The number of days or the dates by which Contractor shall: (a) achieve Milestones, if any; and (b) Completion of the Project.
- (o) Contractor—The individual or entity with which PWC has contracted for performance of the Work and Completion of the Project.
- (p) **Cost of the Work**
 - A. Costs Included: To determine Cost of the Work when Cost of the Work is a component of the Contract Price, except as otherwise may be agreed to in writing by PWC, costs included in the Cost of the Work shall be in amounts no higher than those prevailing in the locality of the Project, shall not include any of the excluded costs specifically itemized below, and shall include only the following items:
 - (i) Payroll costs for employees in the direct employ of Contractor in the performance of the Work under schedules of job classifications agreed upon by Owner and Contractor. Payroll costs for employees not employed full time on the Work shall be apportioned on the basis of their time spent on the Work. Payroll costs shall include, but not be limited to, salaries and wages plus the cost of fringe benefits, which shall include social security contributions, unemployment, excise, and payroll taxes, workers’ compensation, health and retirement benefits, bonuses, sick leave, and vacation and holiday pay applicable thereto. The expenses of performing Work outside of regular working hours, on Saturday, Sunday, or legal holidays, shall be included in the above to the extent authorized by Owner.
 - (ii) Cost of all materials and equipment furnished and incorporated in the Work, including costs of transportation and storage thereof, and Suppliers’ field services required in connection therewith. All trade discounts, rebates, and refunds and returns from sale of surplus materials and equipment shall accrue to Owner, and Contractor shall make provisions so that they may be obtained.
 - (iii) Payments made by Contractor to Subcontractors for Work performed by Subcontractors. If any subcontract provides that the Subcontractor is to be paid on the basis of Cost of the Work plus a fee, the Subcontractor’s Cost of the Work and

fee shall be determined in the same manner as Contractor's Cost of the Work and fee as provided in this subsection (p).

(iv) Supplemental costs including the following:

- a. Rentals of all construction equipment and machinery, and the parts thereof, whether rented from Contractor or others in accordance with rental agreements approved by Owner. All such costs shall be in accordance with the terms of said rental agreements. The rental of any such equipment, machinery, or parts shall cease when the use thereof is no longer necessary for the Work.
- b. Sales, consumer, use, and other similar taxes related to the Work, and for which Contractor is liable, as imposed by Laws and Regulations.
- c. The cost of utilities, fuel, and sanitary facilities at the Site.
- d. The costs of premiums for all bonds and insurance that Contractor is required by the Contract Documents to purchase and maintain.

B. Costs Excluded: The term Cost of the Work shall not include any of the following items:

(i) Payroll costs and other compensation of Contractor's officers, executives, principals (of partnerships and sole proprietorships), general managers, safety managers, engineers, architects, estimators, attorneys, auditors, accountants, purchasing and contracting agents, expeditors, timekeepers, clerks, and other personnel employed by Contractor, whether at the Site or in Contractor's principal or branch office for general administration of the Work and not specifically included in the agreed upon schedule of job classifications agreed upon by Owner and Contractor. The payroll costs and other compensation excluded here are to be considered administrative costs covered by the Contractor's fee.

(ii) Expenses of Contractor's principal and branch offices other than Contractor's office at the Site.

(iii) Any part of Contractor's capital expenses, including interest on Contractor's capital employed for the Work and charges against Contractor for delinquent payments.

(iv) Costs due to the negligence of Contractor, any Subcontractor, or anyone directly or indirectly employed by any of them or for whose acts any of them may be liable, including but not limited to, the correction of defective Work, disposal of materials or equipment wrongly supplied, and making good any damage to property.

(v) Other overhead or general expense costs of any kind and the costs of any item not specifically and expressly included herein.

(vi) Contractor's fee.

A. Documentation: Whenever the Cost of the Work for any purpose is to be determined pursuant to this Article 13, Contractor will establish and maintain records of the Cost of Work in accordance with generally accepted accounting practices and submit in a form acceptable to PWC an itemized cost breakdown together with supporting data.

(q) Day—a calendar day of 24 hours measured from midnight to the next midnight. Also referred to throughout the Contract Documents as "days" or "calendar days."

- (r) Design Engineer—The Engineering firm identified on the Contract Drawings and their duly authorized employees and agents, such employees and agents acting within the scope of the particular duties entrusted to them in each case.
- (s) Drawings—The part of the Contract that graphically shows the scope, extent, and character of the Work to be performed by Contractor.
- (t) Field Order—A written order issued by Project Engineer which requires minor changes in the Work but does not change the Contract Price or the Contract Times.
- (u) Final Completion—The day the on which any specified Work is complete in accordance with the Contract Documents.
- (v) Hazardous Environmental Condition—The presence at the Site of Constituents of Concern in such quantities or circumstances that may present a danger to persons or property exposed thereto. The presence at the Site of materials that are necessary for the execution of the Work, or that are to be incorporated in the Work, and that are controlled and contained pursuant to industry practices, Laws and Regulations, and the requirements of the Contract Documents, does not establish a Hazardous Environmental Condition.
- (w) Laws and Regulations; Laws or Regulations—Any and all applicable laws, statutes, rules, regulations, ordinances, codes, and orders of any and all governmental bodies, agencies, authorities, and courts having jurisdiction. Such terms, unless otherwise specified, shall refer to North Carolina laws and regulations.
- (x) Milestone—A principal event in the performance of the Work that the Agreement requires Contractor to achieve by an intermediate completion date or by a time prior to Completion of the Project.
- (y) Non-Compliance Notice—A written notice issued by PWC to Contractor indicating a violation of any term, provision, or requirement of the Contract Documents.
- (z) Notice of Award—The written notice by PWC to a Bidder providing of PWC's acceptance of the Bid upon timely compliance by the Bidder with any conditions precedent provided in the notice.
- (aa) Notice to Proceed—A written notice by PWC to Contractor fixing the date on which the Contract Times will commence to run and on which Contractor shall start to perform the Work.
- (bb) Progress Schedule—A schedule, prepared and maintained by Contractor, describing the sequence and duration of the activities comprising the Contractor's plan to accomplish the Work within the Contract Times.
- (cc) Project—has the meaning ascribed to it in the Agreement and is as more specifically set forth throughout the Contract Documents. "Project" includes the total undertaking to be accomplished for PWC by engineers, contractors, and others, including planning, study, design, construction, testing, commissioning, and start-up, and of which the Work to be performed under the Contract Documents is a part.

General Conditions (Rev 7/11/2023)

- (dd) Project Engineer—the PWC employee assigned by PWC to coordinate, manage, monitor, and otherwise perform the administration necessary and consistent with PWC’s responsibilities for the Completion of the Project. The Project Engineer has authority to coordinate and work with the Design Engineer regarding any engineering questions, concerns, revisions, alterations, deletions, or additions to the Work, and has authority to approve any changes in the scope of the Work. Project Engineer may assign a “Project Coordinator” who will also be an employee of PWC and have the duties and responsibilities set by the Project Engineer.
- (ee) PWC—Fayetteville Public Works Commission. PWC may also be referred to in the Contract Documents as “Owner.”
- (ff) Samples—Physical examples of materials, equipment, or workmanship that are representative of some portion of the Work and that establish the standards by which such portion of the Work will be judged.
- (gg) Schedule of Submittals—A schedule, prepared and maintained by Contractor, of required submittals and the time requirements for Project Engineer’s review of the submittals and the performance of related construction activities.
- (hh) Schedule of Values—A schedule, prepared and maintained by Contractor, allocating portions of the Contract Price to various portions of the Work and used as the basis for reviewing Contractor’s Applications for Payment.
- (ii) Shop Drawings—All drawings, diagrams, illustrations, schedules, and other data or information that are specifically prepared or assembled by or for Contractor and submitted by Contractor to illustrate some portion of the Work. Shop Drawings, whether approved or not, are not Contract Drawings and are not Contract Documents.
- (jj) Site—Lands or areas indicated in the Contract Documents as being furnished by PWC upon which the Work is to be performed, including rights-of-way and easements, and such other lands furnished by PWC which are designated for the use of Contractor.
- (kk) Specifications—The part of the Contract that consists of written requirements for materials, equipment, systems, standards, and workmanship as applied to the Work, and certain administrative requirements and procedural matters applicable to the Work.
- (ll) Subcontractor—An individual or entity having a direct contract with Contractor or with any other Subcontractor for the performance of a part of the Work.
- (mm) Substantial Completion—The time at which the Work (or a specified part thereof) has progressed to the point where, in the opinion of Project Engineer, the Work (or a specified part thereof) is sufficiently complete, in accordance with the Contract Documents, so that the Work (or a specified part thereof) can be utilized for the purposes for which it is intended. The terms “substantially complete” and “substantially completed” as applied to all or part of the Work refer to Substantial Completion thereof.
- (nn) Successful Bidder—The Bidder whose Bid PWC accepts, and to which PWC provides a Notice of Award.
- (oo) Supplementary Conditions—Any part of the Agreement that amends or supplements these General Conditions.

- (pp) Supplier—A manufacturer, fabricator, supplier, distributor, materialman, or vendor having a direct contract with Contractor or with any Subcontractor to furnish materials or equipment to be incorporated in the Work by Contractor or a Subcontractor.
- (qq) Technical Data—Those items expressly identified as Technical Data in the Supplementary Conditions, with respect to either (a) subsurface conditions at the Site, or physical conditions relating to existing surface or subsurface structures at the Site (except Underground Facilities) or (b) Hazardous Environmental Conditions at the Site. If no such express identifications of Technical Data have been made with respect to conditions at the Site, then the data contained in boring logs, recorded measurements of subsurface water levels, laboratory test results, and other factual, objective information regarding conditions at the Site that are set forth in any geotechnical or environmental report prepared for the Project and made available to Contractor are hereby defined as Technical Data with respect to conditions at the Site under Paragraphs 5.03, 5.04, and 5.06.
- (rr) Underground Facilities—All underground pipelines, conduits, ducts, cables, wires, manholes, vaults, tanks, tunnels, or other such facilities or attachments, and any encasements containing such facilities, including but not limited to those that convey electricity, gases, steam, liquid petroleum products, telephone or other communications, fiber optic transmissions, cable television, water, wastewater, storm water, other liquids or chemicals, or traffic or other control systems.
- (ss) Unit Price Work—Work to be paid for on the basis of unit prices.
- (tt) Work—The entire construction or the various separately identifiable parts thereof required to be provided under the Contract Documents. Work includes and is the result of performing or providing all labor, services, materials, equipment, and documentation necessary to produce such construction; furnishing, installing, and incorporating all materials and equipment into such construction; and may include related services such as testing, start-up, and commissioning, all as required by the Contract Documents and necessary to achieve Completion of the Project.
- (uu) Work Change Directive—A written directive to Contractor issued on or after the Effective Date of the Contract, signed by PWC and recommended by the Project Engineer, ordering an addition, deletion, or revision in the Work.

Section 1.02 Terminology

The words and terms discussed in the following paragraphs are not defined but, when used in the Bidding Requirements or Contract Documents, have the indicated meaning.

- (a) Intent of Certain Terms or Adjectives:
 - (i) The Contract Documents include the terms “as allowed,” “as approved,” “as ordered,” “as directed” or terms of like effect or import to authorize an exercise of professional judgment by Project Engineer. In addition, the adjectives “reasonable,” “suitable,” “acceptable,” “proper,” “satisfactory,” or adjectives of like effect or import are used to describe an action or determination of Project Engineer as to the Work. It is intended that such exercise of professional judgment, action, or determination will be solely to evaluate, in general, the Work for compliance with the information in the Contract Documents and with the design concept of the Project as a functioning whole as shown or indicated in the

General Conditions (Rev 7/11/2023)

Contract Documents (unless there is a specific statement indicating otherwise). The use of any such term or adjective is not intended to and shall not be effective to assign to Project Engineer any duty or authority to supervise or direct the performance of the Work, or any duty or authority to undertake responsibility contrary to the provisions the Contract Documents.

- (b) Defective—when modifying the word “Work,” refers to Work that is unsatisfactory, faulty, or deficient in that it:
 - (i) does not conform to the Contract Documents; or
 - (ii) does not meet the requirements of any applicable inspection, reference standard, test, or approval referred to in the Contract Documents; or
 - (iii) has been damaged prior to Project Engineer’s recommendation of final payment (unless responsibility for the protection thereof has been assumed by PWC at Substantial Completion in accordance with the Contract Documents).
- (c) Furnish, Install, Perform, Provide
 - (i) The word “furnish,” when used in connection with services, materials, or equipment, shall mean to supply and deliver said services, materials, or equipment to the Site (or some other specified location) ready for use or installation and in usable or operable condition.
 - (ii) The word “install,” when used in connection with services, materials, or equipment, shall mean to put into use or place in final position said services, materials, or equipment complete and ready for intended use.
 - (iii) The words “perform” or “provide,” when used in connection with services, materials, or equipment, shall mean to furnish and install said services, materials, or equipment complete and ready for intended use.
 - (iv) If the Contract Documents establish an obligation of Contractor with respect to specific services, materials, or equipment, but do not expressly use any of the four words “furnish,” “install,” “perform,” or “provide,” then Contractor shall furnish and install said services, materials, or equipment complete and ready for intended use.

Unless stated otherwise in the Contract Documents, words or phrases that have a well-known technical or construction industry or trade meaning are used in the Contract Documents in accordance with such recognized meaning.

Article II. Preliminary Matters

Section 2.01 Delivery of Bonds and Evidence of Insurance

- (a) Bonds: Contractor shall deliver to PWC such bonds as Contractor is required to furnish simultaneously with delivering the executed Agreement to PWC.
- (b) Contractor’s Insurance: Contractor shall deliver to PWC the certificates and other evidence of the insurance required by the Contract Documents simultaneously with delivering the executed Agreement to PWC.

Section 2.02 Copies of Documents

- (a) PWC will furnish to Contractor up to five (5) printed copies of the Contract Documents upon request by Contractor, and one (1) copy in electronic portable document format

(PDF). Additional printed copies will be furnished upon request at the cost of reproduction.

- (b) PWC will maintain and safeguard at least one original printed record version of the Agreement, including Drawings and Specifications signed and sealed by Design Engineer or other design professionals as applicable. PWC agrees to make such original printed record version of the Agreement reasonably available to Contractor for review during PWC's normal business hours. PWC may delegate the responsibilities under this provision to Design Engineer.

Section 2.03 Before Starting any Work

- (a) Within ten (10) Days after the Contractor receives the Notice of Award from PWC (or as otherwise specifically required by the Contract Documents), Contractor shall submit to PWC for timely review:
 - (i) a preliminary Progress Schedule indicating the times (numbers of days or dates) for starting and completing the identifiable aspects of the Work, including any Milestones specified in the Contract Documents;
 - (ii) a preliminary Schedule of Submittals; and
 - (iii) Any Shop Drawings, Samples, and other submittals required by the Contract Documents before the Preconstruction Conference.

Section 2.04 Preconstruction Conference; Designation of Authorized Representatives

- (a) Before any Work at the Site is started, a preconstruction conference attended by PWC, Project Engineer, Contractor, Design Engineer, and others as appropriate will be held to establish a working understanding among the parties as to the Work and to discuss general Project issues including, but not limited, the following:
 - (i) The schedules and submittals referred to in Section 2.03;
 - (ii) Contractor's designated authorized representative as described in Section 2.04(b);
 - (iii) Safety;
 - (iv) Procedures for handling Shop Drawings, Samples, and other submittals;
 - (v) Processing Applications for Payment, electronic or digital transmittals;
- (b) At the preconstruction conference Contractor shall designate, in writing, a specific individual to act as its authorized representative with respect to its services and responsibilities under the Contract Documents. Such individual shall have the authority to transmit and receive information, render decisions relative to the requirements of the Contract Documents, and otherwise act on behalf of the Contractor.

Section 2.05 Initial Acceptance of Schedules

- (a) At least twenty (20) Days before submission of the first Application for Payment a conference, attended by Contractor, PWC, and others as appropriate, will be held to review for acceptability to Project Engineer as provided below the schedules submitted in accordance with Paragraph 2.03(a). PWC shall have ten (10) Days to review the submission and provide feedback to Contractor. Contractor shall then have ten (10) days to make any corrections and adjustments as indicated by PWC and to complete and resubmit the schedules as necessary. No progress payment shall be made to Contractor until acceptable schedules are submitted to and approved by Project Engineer.

General Conditions (Rev 7/11/2023)

- (b) The Progress Schedule will be acceptable to Project Engineer if it provides an orderly progression of the Work to achieve Completion of the Project within the Contract Times. Such acceptance will not impose on Project Engineer responsibility for the Progress Schedule, for sequencing, scheduling, or progress of the Work, nor interfere with or relieve Contractor from Contractor's full responsibility therefor.
- (c) Contractor's Schedule of Submittals will be acceptable to Project Engineer if it provides a workable arrangement for reviewing and processing the required submittals.

Section 2.06 Electronic Transmittals

- (a) Except as otherwise stated elsewhere in the Contract Documents, PWC and Contractor and their authorized agents may transmit, and shall accept, Project-related correspondence, text, data, documents, drawings, information, and graphics, including but not limited to Shop Drawings and other submittals, in electronic media or digital format, either directly, or through electronic mail at the address(es) designated by each Party.
- (b) When transmitting items in electronic media or digital format, the transmitting party makes no representations as to long term compatibility, usability, or readability of the items resulting from the recipient's use of software application packages, operating systems, or computer hardware differing from those used in the drafting or transmittal of the items, or from those established in applicable transmittal protocols.

Article III. Contract Documents: Intent, Requirements, Reuse

Section 3.01 Intent

- (a) The Contract Documents are complementary; what is required by one is as binding as if required by all.
- (b) It is the intent of the Contract Documents to describe a functionally complete project (or part thereof) to be constructed in accordance with the Contract Documents.
- (c) Project Engineer, Design Engineer, or both, will issue clarifications and interpretations of the Contract Documents as provided herein.
- (d) To the extent necessary that Work, construction, or conditions not covered by these General Conditions is required for Contractor to achieve Completion of the Project, "Special Conditions" for such Work will be provided to Contractor and shall be part of the Contract Documents.
- (e) In case of any inconsistency, conflict, or ambiguity among the Contract Documents, the documents shall govern in the following order: (1) Change Orders; (2) Addenda; (3) the fully executed Agreement; (4) Special Conditions; (5) any Drawings and Technical Specifications; and (6) General Conditions.

Section 3.02 Reference Standards

- (a) Standards Specifications, Codes, Laws and Regulations

General Conditions (Rev 7/11/2023)

- (i) Reference in the Contract Documents to standard specifications, manuals, reference standards, or codes of any technical society, organization, or association, or to Laws or Regulations, whether such reference be specific or by implication, shall mean the standard specification, manual, reference standard, code, or North Carolina laws and regulations in effect as of the Effective Date of the Agreement, except as may be otherwise specifically stated in the Contract Documents.
- (ii) No provision of any such standard specification, manual, reference standard, or code, or any instruction of a Supplier shall be effective to change the duties or responsibilities of PWC or Contractor, or any of their subcontractors, consultants, agents, or employees, from those set forth in the Contract Documents. No such provision or instruction shall be effective to assign to PWC or any of its officers, directors, members, partners, employees, agents, consultants, or subcontractors, any duty or authority to supervise or direct the performance of the Work or any duty or authority to undertake responsibility inconsistent with the provisions of the part of the Contract Documents.

Section 3.03 Reporting and Resolving Discrepancies

(a) Contractor's Verification of Figures and Measurements

- (i) Before undertaking any portion of the Work, Contractor shall review all of the Contract Documents to and check and verify all figures and dimensions for the Project. Contractor shall promptly report in writing to Project Engineer any conflict, error, ambiguity, or discrepancy that Contractor discovers, or has actual knowledge of, and shall not proceed with any Work affected thereby until the conflict, error, ambiguity, or discrepancy is resolved, by a clarification or interpretation by Project Engineer, or by an amendment or supplement to the Contract Documents issued pursuant to these General Conditions.
- (ii) If, before or during the performance of the Work, Contractor discovers any conflict, error, ambiguity, or discrepancy within the Contract Documents, or between the Contract Documents and (a) any applicable Law or Regulation, (b) actual field conditions, (c) any standard specification, manual, reference standard, or code, or (d) any instruction of any Supplier, then Contractor shall promptly report it to Project Engineer in writing. Contractor shall not proceed with the Work affected thereby (except in an emergency as defined hereinafter) until the conflict, error, ambiguity, or discrepancy is resolved, by a clarification or interpretation by Project Engineer, or by an amendment or supplement to the Contract Documents issued pursuant to these General Conditions.

(b) Resolving Discrepancies:

- (i) Except as may be otherwise specifically stated in the Contract Documents, the provisions of the part of the Contract Documents prepared by or for PWC shall take precedence in resolving any conflict, error, ambiguity, or discrepancy between such provisions of the Contract Documents and:
 - 1) the provisions of any standard specification, manual, reference standard, or code, or the instruction of any Supplier (whether or not specifically incorporated by reference as a Contract Document); or
 - 2) the provisions of any Laws or Regulations applicable to the performance of the Work (unless such an interpretation of the provisions of the Contract Documents would result in violation of such Law or Regulation).

Section 3.04 Reuse of Documents

- (a) Contractor and its Subcontractors and Suppliers shall not have or acquire any title to or ownership rights in any of the:
 - (i) Drawings, Specifications, or other documents (or copies of any thereof) prepared by or bearing the seal of Design Engineer or its consultants, including electronic media editions, or reuse any such Drawings, Specifications, other documents, or copies thereof on extensions of the Project or any other project without written consent of PWC and Design Engineer and specific written verification or adaptation by Design Engineer, where applicable; or
 - (ii) Contract Documents and shall not reuse any such Contract Documents for any purpose without PWC's express written consent.
- (b) The prohibitions of this provision shall survive final payment or termination of the Agreement. Nothing herein shall preclude Contractor from retaining copies of the Contract Documents for record purposes.

Article IV. Commencement and Progress of the Work

Section 4.01 Commencement of Work

- (a) The Contract Times will commence to run on the day indicated in the Notice to Proceed issued by PWC to Contractor. A Notice to Proceed may be given at any time after the Effective Date of the Contract.
- (b) Contractor shall start to perform the Work on the date when the Contract Times commence to run. No Work shall be done at the Site prior to such date. Contractor's failure to commence the Work within fifteen (15) Days of the date stated in the Notice to Proceed shall be deemed a material breach of the Agreement unless PWC otherwise determines in its sole discretion and agrees in writing to a delay of the Contract Times based on the applicable circumstances.

Section 4.02 Reference Points

- (a) Construction staking will be performed by Design Engineer, who will also prepare and furnish construction cut sheets, signed and sealed by a North Carolina professional land surveyor, to PWC and Contractor. Contractor shall not install any utilities without a sheet. All requests for staking shall be made not less than 96 hours in advance.
- (b) Contractor shall be responsible for laying out the Work, shall protect and preserve the established reference points and staking, and shall make no changes or relocations without the prior written approval of Project Engineer. Contractor shall report to Project Engineer whenever any reference point staking is lost or destroyed or requires relocation because of necessary changes in grades or locations, and shall be responsible for the accurate replacement or relocation of such reference points or staking by professionally qualified personnel.

Section 4.03 Progress Schedule

- (a) Contractor shall adhere to the Progress Schedule established in accordance with Section 2.03 as it may be adjusted from time-to-time as provided below. Contractor shall submit to Project Engineer for acceptance any proposed adjustments in the Progress Schedule that will not result in changing the Contract Times. Proposed adjustments in the Progress Schedule that will change the Contract Times shall be submitted in accordance with the requirements of Article IX.
- (b) Contractor shall carry on the Work and adhere to the Progress Schedule during any disputes or disagreements with PWC. No Work shall be delayed or postponed pending resolution of any disputes or disagreements, or during any appeal process, except as permitted by these General Conditions or as PWC and Contractor may otherwise agree in writing.

Section 4.04 Delays in Contractor's Progress

- (a) If PWC, Project Engineer, anyone for whom PWC is responsible, or a Force Majeure Event delays, disrupts, or interferes with the performance or progress of the Work, then Contractor shall be entitled to an equitable adjustment in the Contract Times and Contract Price. Contractor's entitlement to an adjustment of the Contract Times is conditioned on such adjustment being essential to Contractor's ability to complete the Work within the Contract Times.
- (b) Contractor shall not be entitled to an adjustment in Contract Price or Contract Times for delay, disruption, or interference caused by or within the control of Contractor. Delay, disruption, and interference attributable to and within the control of a Subcontractor or Supplier shall be deemed to be within the control of Contractor.
- (c) Contractor must submit any Change Proposal, consistent with the procedure set forth in Article IX, seeking an adjustment in Contract Price or Contract Times under this provision within ten (10) calendar days of the commencement of the event that causes the delay, disruption, or interference with the Work and Contract Times.

Article V. Availability of Lands; Subsurface and Physical Conditions; Hazardous Environmental Conditions

Section 5.01 Availability of Lands

- (a) PWC will be responsible for obtaining any required easements and encroachments, and otherwise furnishing the Site, necessary to complete the Work, except as provided elsewhere in the Contract Documents.
- (b) Upon reasonable written request, PWC shall furnish to Contractor a current statement of record legal title and legal description of the lands upon which the Work is to be completed and PWC's interest therein.
- (c) Contractor shall provide for all additional lands and access thereto that may be required for temporary construction facilities or storage of materials and equipment necessary to complete the Work. Any and all agreements between the Contractor and any individual property owner(s) shall not obligate PWC, PWC's employees, Project Engineer, or Design

General Conditions (Rev 7/11/2023)

Engineer in any manner, and Contractor shall, before performing any work on any such property, obtain a signed and notarized release of liability of PWC and Design Engineer that is suitable to PWC as confirmed in writing.

- (d) Contractor and any of its Subcontractors shall exercise care and caution to avoid damage to any private property. Should any such damage to private property occur, it is Contractor's responsibility to notify the Project Engineer promptly in writing that such damage occurred, the extent of the damage, and Contractor's written plan to remedy the damage. If Contractor fails to timely correct damage to private property, PWC reserves the right to withhold progress payments until damage is corrected and/or to correct damage and back-charge Contractor for costs incurred. At the Completion of the Project, Contractor shall obtain a signed release from all owners of private property to which damage occurred that releases PWC and Design Engineer and acknowledges a settlement for the damage or that such damage was adequately remedied.

Section 5.02 Use of Site and Other Areas

- (a) Contractor shall confine construction equipment, temporary construction facilities, the storage of materials and equipment, and the operations of workers to the Site and other adjacent areas permitted by Laws and Regulations and shall not unreasonably encumber the Site and such other adjacent areas with construction equipment or other materials or equipment. Contractor shall assume full responsibility for (a) damage to the Site; (b) damage to any such other adjacent areas used for Contractor's operations; (c) damage to any other adjacent land or areas; and (d) for injuries and losses sustained by the owners or occupants of any such land or areas; provided that such damage or injuries result from the performance of the Work or from other actions or conduct of the Contractor or those for which Contractor is responsible.
- (b) Contractor shall keep the Site and other adjacent areas free from accumulations of waste materials, rubbish, and other debris during the progress of the Work. Removal and disposal of such debris shall conform to applicable Laws and Regulations.
- (c) Prior to Completion of the Project, Contractor shall clean the Site and the Work and make it ready for utilization by PWC. At the completion of all of the Work, Contractor shall remove from the Site and adjacent areas all tools, appliances, construction equipment and machinery, and surplus materials and shall restore to original condition all property not designated for alteration by the Contract Documents.
- (d) Contractor shall not load nor permit any part of any structure to be loaded in any manner that will endanger the structure, nor shall Contractor subject any part of the Work or adjacent structures or land to stresses or pressures that will endanger them.

Section 5.03 Differing Subsurface or Physical Conditions or Underground Facilities

- (a) If Contractor believes that any subsurface or physical condition or Underground Facilities that is uncovered or revealed at the Site either:
 - (i) is of such a nature as to establish that any Technical Data on which Contractor is entitled to rely is materially inaccurate;
 - (ii) is of such a nature as to require a change in the Contract Documents;
 - (iii) differs materially from that shown or indicated in the Contract Documents; or

General Conditions (Rev 7/11/2023)

- (iv) is of an unusual nature, and differs materially from conditions ordinarily encountered and generally recognized as inherent in work of the character provided for in the Contract Documents;

then Contractor shall, promptly after becoming aware thereof and before further disturbing the subsurface or physical conditions or Underground Facilities or performing any Work in connection therewith, notify PWC and Engineer in writing about such condition. Contractor shall not further disturb such condition or perform any Work in connection therewith (except with respect to an emergency) until receipt of a written statement approved by PWC permitting Contractor to do so.

- (b) After receipt of Contractor's written notice, Project Engineer will review the subsurface or physical condition or Underground Facilities in question; determine the necessity of PWC obtaining additional exploration or tests with respect to the condition; conclude whether the condition falls within any of the differing site condition categories in this Section 5.03; and obtain any pertinent cost or schedule information from Contractor.
- (c) Project Engineer will issue a written statement to Contractor regarding the subsurface or physical condition or Underground Facilities in question, which addresses the resumption of Work in connection with such condition and indicates whether any change in the Contract Documents will be made.
- (d) Possible Price and Times Adjustments:
 - (i) Contractor shall be entitled to an equitable adjustment in Contract Price or Contract Times, or both, to the extent that the existence of a differing subsurface or physical condition or Underground Facilities, or any related delay, disruption, or interference, causes an increase or decrease in Contractor's cost of, or time required for, performance of the Work; subject, however, to the following:
 - 1) such condition must fall within at least one of the categories in this Section 5.03; and,
 - 2) Contractor's entitlement to an adjustment of the Contract Times is conditioned on such adjustment being essential to Contractor's ability to complete the Work within the Contract Times.
 - (ii) Contractor shall not be entitled to any adjustment in the Contract Price or Contract Times with respect to a subsurface or physical condition or Underground Facilities if:
 - 1) Contractor knew of the existence of such condition at the time Contractor proffered its Bid to PWC or executed the applicable Agreement for the Project; or
 - 2) the existence of such condition reasonably could have been discovered or revealed as a result of any examination, investigation, exploration, test, or study of the Site and contiguous areas expressly required by the Bidding Requirements or Contract Documents to be conducted by or for Contractor prior to Contractor's Bid; or
 - 3) Contractor failed to give the written notice as required.
 - (iii) If PWC and Contractor agree regarding Contractor's entitlement to, and the amount or extent of, any adjustment in the Contract Price or Contract Times, or both, then any such adjustment shall be set forth in a Change Order.
 - (iv) Contractor may submit a Change Proposal regarding its entitlement to or the amount or extent of any adjustment in the Contract Price or Contract Times, or both, no later than 30 calendar days after Project Engineer's written statement to Contractor regarding the

subsurface or physical condition or Underground Facilities in question.

Section 5.04 Underground Utilities

- (a) Contractor shall ascertain the location and type of all underground utility lines or structures that may be located within the limits of the Site or any area where Work is to be performed.
 - (i) The exact location of underground utilities or structures may vary from prior plans, permits, maps, or other documentation, and others may not be designated. The Contractor is fully responsible for verification of the exact location of all underground utility lines or structures within the limits of the Site or the area where the work is to be performed, whether known or unknown by PWC, and for providing necessary protection and/or repair if damage.
 - (ii) Should uncharted or incorrectly charted piping or other utilities be encountered during excavations, the Contractor shall immediately halt any Work, notify PWC, and await direction from PWC before proceeding with any Work. The Contractor shall fully cooperate with PWC and any other utility company in keeping respective services and facilities in operation.
- (b) PWC has used reasonable care to locate and depict existing underground installation on the construction drawings, but the accuracy cannot be guaranteed, and some items may not be shown which exist. Actual horizontal and vertical locations have not been verified. As part of the Work, the Contractor is required to dig up each utility which may conflict with construction in advance to verify locations. The utilities shall be “dug up” a minimum of fourteen (14) Days in advance of actual installation of new utilities to allow PWC an opportunity to adjust grades and alignments, to avoid a conflict, and to address any other issues.
- (c) The Contractor shall adhere to the provisions of the North Carolina Underground Utility Safety and Damage Prevention Act. The Contractor shall make a documented request to the North Carolina One Call Center, and/or individual utility owners, in order to locate any facilities within the Site limits or any area where Work is to be performed at least forty-eight (48) hours in advance of the day the Work is scheduled to begin. The Contractor shall include the cost of any coordination and cooperation for utilities in its Bid.
 - (i) Location assistance requested from PWC by Contractor should include the actual horizontal location, type number, size, and depth of all lines. All costs associated with locating and marking existing utilities or the utilities representatives shall be the responsibility of the Contractor.
 - (ii) The Owner, Project Engineer, Design Engineer, and/or Consultants shall not be liable to the Contractor for any claims, costs, losses, or damages incurred or sustained on or in connection with locating existing underground installations.
- (d) If the Contractor fails to schedule locates or perform advance physical locations in advance of the construction and a conflict arises, the Contractor will be required to make corrective measures as instructed by the Project Engineer at the Contractor’s expense. The Contractor’s failure to advance plan (minimum fourteen (14) days) by physically

General Conditions (Rev 7/11/2023)

uncovering existing utilities in advance of construction shall not be cause for claim of lost time or for additional compensation. No additional payment will be made for re-mobilization required by the utility locator.

- (i) The Contractor shall inform all equipment operators, either those employed by him or those employed by his subcontractors, of information obtained from the utility owners prior to initiation of any aspect of any Work.
- (e) PWC and Design Engineer shall not be responsible for the accuracy or completeness of any information or data provided to the Contractor with respect to underground facilities.
- (f) The entire cost of all of the following will be included in the Contract Price, and Contractor shall bear full responsibilities for all such costs, including but not limited to:
 - (i) Reviewing and checking all such information and data;
 - (ii) Locating all underground facilities shown or indicated in the Contract Documents;
 - (iii) Coordination of the Work with the owners of such underground facilities, including PWC, during any portion of the Work; and
 - (iv) The safety and protection of all such underground facilities and repairing any damage thereto resulting from the Work.
- (g) Contractor shall be responsible for the discovery of existing underground installations, in advance of any excavating or trenching as required in the Contract Documents.
- (h) If an underground facility is discovered at or contiguous to the Site that was not shown or indicated in the Contract Documents or of which Contractor was not aware prior to starting that portion of any Work, Contractor shall, immediately after becoming aware thereof and before further disturbing conditions affected thereby or performing any Work in connection therewith (except in an emergency), identify the owner of such underground facility and give written notice to PWC. Upon receipt of written notice, PWC will review the pertinent condition, determine the necessity of obtaining additional information, and advise Contractor in writing. During such time, Contractor shall be responsible for the safety and protection of such underground facility. If PWC concludes that a change in the Contract Documents is required, a Change Order will be issued.
- (i) The Contract Price and/or the Contract Time, may be adjusted if PWC determines, in its discretion, that the existence of such differing subsurface or physical condition causes an increase or decrease in Contractor's cost of, or time required for, performance of the Work subject to the following:
 - 1) Facility was not shown or indicated in the Contract Documents, and
 - 2) The Contractor did not know of or could not anticipate the facility.

Section 5.05 Hazardous Environmental Conditions at Site

- (a) Contractor shall not be responsible for removing or remediating any Hazardous Environmental Condition encountered, uncovered, or revealed at the Site unless such removal or remediation is expressly identified in the Contract Documents to be within the scope of the Work or Hazardous Environmental Condition was caused by Contractor.
- (b) Contractor shall be responsible for controlling, containing, and removing all Constituents of Concern brought to the Site by Contractor, Subcontractors, Suppliers, or anyone else for whom Contractor is responsible, and for any associated costs; and for the costs of removing and remediating any Hazardous Environmental Condition created by the presence of any such Constituents of Concern.
- (c) If Contractor encounters, uncovers, or reveals a Hazardous Environmental Condition whose removal or remediation is not expressly identified in the Contract Documents as being within the scope of the Work, or if Contractor or anyone for whom Contractor is responsible creates a Hazardous Environmental Condition, then Contractor shall immediately: (1) secure or otherwise isolate such condition; (2) stop all Work in connection with such condition and in any area affected thereby (except in an emergency); and (3) immediately notify Project Engineer (and promptly thereafter confirm such notice in writing). Project Engineer will evaluate such condition or take corrective action, if any. If Contractor or anyone for whom Contractor is responsible created the Hazardous Environmental Condition in question, then PWC may have the Hazardous Environmental Condition removed and remediated and impose a set-off against payments to Contractor to account for the reasonable associated costs.
- (d) Contractor shall not resume Work in connection with such Hazardous Environmental Condition or in any affected area until after PWC has delivered written notice to Contractor either (1) specifying that such condition and any affected area is or has been rendered safe for the resumption of Work, or (2) specifying any special conditions under which such Work may be resumed safely.
- (e) If PWC and Contractor cannot agree as to entitlement to or on the amount or extent, if any, of any adjustment in Contract Price or Contract Times, or both, as a result of such Work stoppage or such special conditions under which Work is agreed to be resumed by Contractor, then within thirty (30) calendar days of PWC's written notice regarding the resumption of Work, Contractor may submit a Change Proposal or PWC may impose a set-off.
- (f) If after receipt of such written notice Contractor does not agree to resume such Work based on reasonable evidence it is unsafe or does not agree to resume such Work under such special conditions, then PWC may order the portion of the Work that is in the area affected by such condition to be deleted from the Work.

Article VI. Bonds and Insurance

Section 6.01 Performance and Payment Bonds

- (a) Contractor shall obtain and furnish to PWC a performance bond in the amount of one hundred percent (100%) of the Contract Price, conditioned upon the faithful performance of the Project and all Work in accordance with the Contract Documents, which bond shall be

solely for the protection of PWC.

- (b) Contractor shall obtain and furnish to PWC a payment bond in the amount of one hundred percent (100%) of the Contract Price, conditioned upon the prompt payment for all labor or materials for which the Contractor or one or more of its subcontractors is liable, which payment bond shall be solely for the protection of the persons furnishing materials or performing labor for which the Contractor is liable.
- (c) The performance bond and the payment bond shall be executed by one or more surety companies legally authorized to do business in the State of North Carolina, shall become effective upon the awarding of the construction contract by PWC to Contractor, and shall at all times comply with the requirements set forth in Article 3 of North Carolina General Statutes Chapter 44A.
- (d) In the event PWC deems the surety or sureties upon any bond necessary for the Agreement and the completion of the Project, or if for any reason, such bond ceases to be adequate to cover the performance and/or payment of the Work, Contractor shall, at its expense, and within ten (10) days after the receipt of notice from PWC, furnish such additional bond(s) in such form and amount, and with such surety or sureties, as shall be satisfactory to PWC. In such event no further payment to Contractor shall be deemed to be due under this Agreement until new or additional security for the performance and payment of the Project shall be furnished in manner and form satisfactory to PWC.
- (e) By executing the Agreement, Contractor understands and acknowledges that PWC, as a public authority, and the City, as a municipal corporation, are not subject to the provisions of Articles 1 and 2 of Chapter 44A of the General Statutes, in accordance with G.S. 44A-34 and applicable law.

Section 6.02 Insurance

- (a) Contractor shall maintain during the life of the Agreement and during the completion of any Work the following insurance coverages, which insurance shall be placed with insurance companies authorized to do business in the State of North Carolina and rate A minus VII or better by the current edition of Best's Key Rating Guide or otherwise approved in writing by PWC:
 - (i) Commercial general liability insurance with limits of \$1,000,000 per occurrence, \$2,000,000 aggregate other than products/completed operations; \$2,000,000 aggregate for products/completed. Commercial general liability coverage shall be written on an "occurrence" basis.
 - (ii) Automobile liability insurance in an amount not less than \$1,000,000 combined single limit per accident for bodily injury and property damage from owned, non-owned, and hired automobiles.
 - (iii) Workers' compensation insurance as required by the Laws and Regulations. In the event any employee(s), contractor(s), or subcontractor(s) engaged to perform any Work under the Agreement is not protected under the applicable workers' compensation laws, the Contractor shall provide adequate coverage for the protection of such employee(s), contractor(s), or subcontractor(s) not otherwise protected.

General Conditions (Rev 7/11/2023)

- (iv) In the event the Project concerns building construction or repair work, Contractor shall purchase and maintain "Builder's Risk" insurance. This insurance shall include the interests of the PWC, Contractor, and any Subcontractor(s) and shall be written on a one hundred percent (100%) completed value basis (full value as of the date that all construction is finished and includes the Contractor's Contract Price), and to remain in force until Completion of the Project.
- (v) Regardless of the nature of the work to be performed, coverage must also be provided for the theft or damage of building materials and supplies, which are not permanently attached or stored on Site for any period of time. This coverage shall be an "Installation Floater." If no building construction or repair is involved for the Project, the amount of the coverage shall equal the value of the materials stored on site.
- (b) Prior to initiating any Work on the Project, Contractor shall deliver certificates of insurance confirming each such coverage set forth above, and Contractor shall direct its insurers to provide annually to PWC certificates confirming each such coverage during the coverage period.
- (c) PWC shall be named as an additional insured in the comprehensive automobile and commercial liability insurance policies.
- (d) Contractor shall not reduce or allow the required insurance coverages to lapse without PWC's prior written approval. All policies for insurance must be endorsed to contain a provision giving PWC a thirty (30) calendar day prior written notice by certified mail of any cancellation of that policy or material reduction in coverage. Should a notice of cancellation be issued for non-payment of premiums or any part thereof, or should Contractor fail to provide and maintain certificates as set forth herein, PWC shall have the right, but shall not have the obligation, to pay such premium to the insurance company or to obtain such coverage and to deduct such payment from any sums that may be due or become due to Contractor, or to seek reimbursement for said payments from Contractor. Any such sums paid by PWC shall be due and payable immediately by Contractor upon notice from PWC.
- (e) The insurance coverage requirements shall not be construed as a limitation on Contractor's responsibilities and liabilities pursuant to the terms and conditions of this Agreement. Contractor's obligation to maintain insurance for three (3) years after Completion of the Project shall survive the termination of this Agreement.
- (f) If Contractor fails to obtain and maintain any required insurance, PWC may exclude Contractor from the Site, impose an appropriate set-off against payment, and exercise PWC's termination rights pursuant to the Contract Documents.
- (g) PWC does not represent that insurance coverage and limits established in this Contract necessarily will be adequate to protect Contractor or Contractor's interests.

Article VII. Contractor's Responsibilities

Section 7.01 Supervision and Superintendence

- (a) Contractor shall supervise, inspect, and direct the Work competently and efficiently, devoting such attention and applying such skills and expertise as may be necessary to

General Conditions (Rev 7/11/2023)

perform the Work in accordance with the Contract Documents. Contractor shall be solely responsible for the means, methods, techniques, sequences, and procedures of construction subject to the terms, provisions, and specifications set forth in the Contract Documents.

- (b) At all times during the progress of the Work, Contractor shall assign a competent superintendent, satisfactory to Project Engineer, to supervise the Work and to respond to Project Engineer concerning PWC's interests in the Work.
- (c) Contractor's superintendent shall have full authority to act on behalf of Contractor and all communications, instructions, directions, and notices given to the superintendent by the Project Engineer shall be binding to the Contractor.
- (d) Contractor's superintendent shall be responsible for coordination of the Work with other contractors or subcontractors. The superintendent shall not be replaced without written notice to PWC except under extraordinary circumstances.
- (e) Subcontractors
 - (i) Contractor shall submit the names and references all Subcontractors to the Project Engineer for approval before commencing any Work.
 - 1) In the event Contractor seeks to substitute any Subcontractor that was identified in Contractor's Bid, Contractor shall promptly provide PWC with: (1) the Subcontractor it seeks to substitute; (2) the identity of the Subcontractor to be substituted; and (3) the reason for the requested substitution.
 - 2) PWC will review the requested substitution within five (5) Business Days and provide written approval or denial of the substitution, with such approval not to be unreasonably withheld.
 - (ii) Contractor's superintendent shall be available to be present at the Site at any time that any Subcontractor(s) is performing any of the Work. Construction activity shall be stopped if the Contractor's superintendent is not available to be at the Site.

Section 7.02 Labor; Working Hours

- (a) Contractor shall provide competent, suitably qualified personnel to survey and lay out the Work and perform construction as required by the Contract Documents. Contractor shall at all times maintain good discipline and order at the Site. Contractor shall remove from the Project any person who appears incompetent, disorderly, or otherwise unsatisfactory. Contractor shall also remove any person who appears in PWC's sole discretion to be incompetent, disorderly, or otherwise unsatisfactory
- (b) Except as otherwise required for the safety or protection of persons or the Work or property at the Site or adjacent thereto, and except as otherwise stated in the Contract Documents, all Work at the Site shall be performed on Business Days. Contractor will not perform Work on non-Business Days. Contractor may perform Work outside regular working hours or on Saturdays, Sundays, or legal holidays only with PWC's written consent, which will not be unreasonably withheld. In such circumstances, Contractor shall submit a written request to PWC at least two (2) Business Days prior to any Work that it requests to complete on a

non-Business Day and PWC will, in its sole discretion, approve or deny such request. If such work outside of a Business Day is approved, PWC will set forth the specific parameters that Contractor must follow, including time of work, personnel, and any other issues.⁸

Section 7.03 Services, Materials, and Equipment

- (a) Unless otherwise specified in the Contract Documents, Contractor shall provide and assume full responsibility for all services, materials, equipment, labor, transportation, construction equipment and machinery, tools, appliances, fuel, power, light, heat, telephone, water, sanitary facilities, temporary facilities, and all other facilities and incidentals necessary for the performance, testing, start up, and Completion of the Project, whether or not such items are specifically called for in the Contract Documents.
- (b) All materials and equipment incorporated into the Work shall be of good quality and new, except as otherwise specified in the Contract Documents. All special warranties and guarantees required by the Specifications shall expressly run to the benefit of PWC. If required by PWC or its designee, Contractor shall furnish satisfactory evidence (including reports of required tests) as to the source, kind, and quality of materials and equipment.
- (c) All materials and equipment shall be stored, applied, installed, connected, erected, protected, used, cleaned, and conditioned in accordance with instructions of the applicable Supplier, except as otherwise may be specified in the Contract Documents.

Section 7.04 "Or Equals"

- (a) Whenever an item of material or equipment is specified or described in the Contract Documents by using the name of a proprietary item or the name of a particular Supplier, the specification or description of such an item is intended to establish the type, function, appearance, and quality required. Unless the specification or description contains or is followed by words reading that no like, equivalent, or "or equal" item is permitted, Contractor may request that Project Engineer authorize the use of other items of material or equipment under the circumstances described below.
 - (i) If Project Engineer determines that an item of material or equipment proposed by Contractor is functionally equal to that named and sufficiently similar so that no change in related Work will be required, Project Engineer shall deem it an "or equal" item and confirm such in writing to Contractor. A proposed item of material or equipment will be considered functionally equal to an item so named if:
 - 1) in the exercise of reasonable judgment Project Engineer determines that:
 - a) it is at least equal in materials of construction, quality, durability, appearance, strength, and design characteristics;
 - b) it will reliably perform at least equally well the function and achieve the results imposed by the design concept of the completed Project as a functioning whole;
 - c) it has a proven record of performance and availability of responsive service; and
 - d) it is not objectionable to PWC.
 - 2) Contractor certifies that, if approved and incorporated into the Work:
 - a) there will be no increase in the Contract Price or Contract Times; and

General Conditions (Rev 7/11/2023)

- b) it will conform substantially to the detailed requirements of the item specified in the Contract Documents.
- (b) Contractor shall provide all data in support of any proposed “or equal” item at Contractor’s expense.
- (c) Project Engineer will be allowed a reasonable time to evaluate each “or-equal” request. Project Engineer may require Contractor to furnish additional data about the proposed “or-equal” item. Project Engineer will be the sole judge of acceptability. Contractor shall not order, furnish, install, or utilize any “or-equal” it until Project Engineer has reviewed the request, determined that the proposed item is an “or-equal,” and provided written confirmation to Contractor.
- (d) Project Engineer’s denial of an “or-equal” request shall be final and binding and may not be reversed through an appeal under any provision of the Contract Documents.

Section 7.05 Concerning Subcontractors, Suppliers, and Others

- (a) Contractor may retain Subcontractors and Suppliers for the performance of parts of the Work. Such Subcontractors and Suppliers must be acceptable to PWC.
- (b) Contractor shall not subcontract more than forty-nine percent (49%) of the final Contract Price.
- (c) Contractor shall retain specific Subcontractors, Suppliers, or other individuals or entities for the performance of designated parts of the Work if required by the Contract Documents.
- (d) After the submittal of Contractor’s Bid or final negotiation of the terms of the Agreement, PWC may not require Contractor to retain any Subcontractor, Supplier, or other individual or entity to furnish or perform any of the Work.
- (e) Prior to entry into any binding subcontract or purchase order, Contractor shall submit to PWC the identity of the proposed Subcontractor or Supplier (unless PWC has already deemed such proposed Subcontractor or Supplier acceptable, during the bidding process or otherwise). Such proposed Subcontractor or Supplier shall be deemed acceptable to PWC unless PWC raises a substantive, reasonable objection within five (5) Business Days.
- (f) No acceptance by PWC of any such Subcontractor, Supplier, or other individual or entity, whether initially or as a replacement, shall constitute a waiver of the right of PWC to the completion of the Work in accordance with the Contract Documents.
- (g) Contractor shall be fully responsible to PWC for all acts and omissions of the Subcontractors, Suppliers, and other individuals or entities performing or furnishing any of the Work just as Contractor is responsible for Contractor’s own acts and omissions.
- (h) Contractor shall be solely responsible for scheduling and coordinating the Subcontractors, Suppliers, and all other individuals or entities performing or furnishing any of the Work.
- (i) Contractor shall restrict all Subcontractors, Suppliers, and such other individuals or entities performing or furnishing any of the Work from communicating with PWC, except through Contractor or in case of an emergency, or as otherwise expressly allowed herein.

- (j) All Work performed for Contractor by a Subcontractor or Supplier shall be pursuant to an appropriate contractual agreement that specifically binds the Subcontractor or Supplier to the applicable terms and conditions of the Contract Documents for the benefit of PWC.
- (k) PWC may furnish to any Subcontractor or Supplier, to the extent practicable, information about amounts paid to Contractor on account of Work performed for Contractor by the particular Subcontractor or Supplier.
- (l) Nothing in the Contract Documents:
 - (i) shall create for the benefit of any such Subcontractor, Supplier, or other individual or entity any contractual relationship between PWC or Design Engineer and any such Subcontractor, Supplier, or other individual or entity; nor
 - (ii) shall create any obligation on the part of PWC or Design Engineer to pay or to see to the payment of any money due any such Subcontractor, Supplier, or other individual or entity except as may otherwise be required by Laws and Regulations.

Section 7.06 Patent Fees and Royalties

- (a) Contractor shall pay all license fees and royalties and assume all costs incident to the use in the performance of the Work or the incorporation in the Work of any invention, design, process, product, or device that is the subject of patent rights or copyrights held by others. If a particular invention, design, process, product, or device is specified in the Contract Documents for use in the performance of the Work and if, to the actual knowledge of PWC, its use is subject to patent rights or copyrights calling for the payment of any license fee or royalty to others, the existence of such rights shall be disclosed by PWC in the Contract Documents.

Section 7.07 Permits

- (a) Unless otherwise specified in the Contract Documents, Contractor shall obtain and pay for all construction permits and licenses necessary to achieve Completion of the Project. Contractor shall timely seek assistance from PWC if necessary to obtain any permits or licenses; provided that, the Contract Time shall not be extended if PWC determines, in its discretion, that Contractor delayed or otherwise did not act expeditiously in requesting such assistance. PWC shall assist Contractor, when necessary, in obtaining such permits and licenses. Contractor shall pay all governmental charges and inspection fees necessary for Completion of the Project that are applicable at the time of the submission of Contractor's Bid.

Section 7.08 Taxes

- (a) Contractor shall pay all sales, consumer, use, and other similar taxes required to be paid by Contractor in accordance with the applicable Laws and Regulations for the Project and which are applicable during the performance of the Work.

Section 7.09 Laws and Regulations

- (a) Contractor shall give all notices required by, and shall comply with, all Laws and Regulations applicable to the Project. Except as otherwise expressly required, PWC shall

General Conditions (Rev 7/11/2023)

not be responsible for monitoring Contractor's compliance with any Laws or Regulations.

- (b) Contractor shall bear all resulting costs and losses for any of its actions or inactions that are contrary to Laws or Regulations.
- (c) PWC or Contractor may give notice to the other party of any changes after the submission of Contractor's Bid (or after the date when Contractor became bound under the Agreement) concerning any Laws or Regulations having an effect on the Contract Price or Contract Times, including but not limited to changes in Laws or Regulations having an effect on procuring permits and on sales, use, value-added, consumption, and other similar taxes. If PWC and Contractor are unable to agree on entitlement to or on the amount or extent, if any, of any adjustment in Contract Price or Contract Times resulting from such changes, then within 30 calendar days of such notice Contractor may submit a Change Proposal.

Section 7.10 Record Documents

- (a) Contractor shall maintain in good order one (1) printed record copy of all Drawings, Specifications, Addenda, Change Orders, Work Change Directives, Field Orders, written interpretations and clarifications, and approved Shop Drawings. These record documents, together with all approved Samples, will be available to Project Engineer for reference. Upon completion of the Work, Contractor shall deliver these record documents to PWC.

Section 7.11 Safety and Protection

- (a) Contractor shall be solely responsible for initiating, maintaining, and supervising all safety precautions and programs in connection with the Work. Such responsibility does not relieve Subcontractors of their responsibility for the safety of persons or property in the performance of their work, nor for compliance with applicable safety Laws and Regulations. Contractor shall take all necessary precautions for the safety of, and shall provide the necessary protection to prevent damage, injury, or loss to:
 - (i) all persons on the Site or who may be affected by the Work;
 - (ii) all the Work and materials and equipment to be incorporated therein, whether in storage on or off the Site; and
 - (iii) other property at the Site or adjacent thereto, including trees, shrubs, lawns, walks, pavements, roadways, structures, other work in progress, utilities, and Underground Facilities not designated for removal, relocation, or replacement in the course of construction.
- (b) Contractor shall comply with all applicable Laws and Regulations relating to the safety of persons or property, or to the protection of persons or property from damage, injury, or loss, and shall erect and maintain all necessary safeguards for such safety and protection. Contractor shall notify PWC, the owners of adjacent property or Underground Facilities, and other contractors and owners performing work at or adjacent to the Site, when prosecution of the Work may affect them, and shall cooperate with them in the protection, removal, relocation, and replacement of their property or work in progress.
- (c) Contractor shall comply with the requirement of any of PWC's applicable health programs, which may be revised from time to time based on specific circumstances or applicable guidance from the Center for Disease Control or other applicable entity. Such health programs will be identified in the Special Conditions if applicable to the Project.

- (d) Contractor shall comply with the requirements of PWC's applicable safety programs. The Special Conditions identify any of PWC's safety programs that are applicable to the Project.
- (e) Contractor shall remedy, at its expense, all damage, injury, or loss to any property caused, directly or indirectly, in whole or in part, by Contractor, any Subcontractor, Supplier, or any other individual or entity directly or indirectly employed by any of them to perform any of the Work, or anyone for whose acts any of them may be liable.
- (f) Contractor's duties and responsibilities for safety and protection shall continue until such time as Completion of the Project is achieved.
- (g) Contractor's duties and responsibilities for safety and protection shall resume whenever Contractor or any Subcontractor or Supplier returns to the Site to fulfill warranty or correction obligations, or to conduct other tasks arising from the Contract Documents.
- (h) Contractor shall designate in writing to PWC a qualified and experienced safety representative at the Site whose duties and responsibilities shall be the prevention of accidents and the maintaining and supervising of safety precautions and programs.

Section 7.12 Emergencies

- (a) In emergencies affecting the safety or protection of persons or the Work or property at the Site or adjacent thereto, Contractor is obligated to, and shall, act to prevent threatened damage, injury, or loss. Contractor shall give PWC prompt written notice if Contractor believes that any significant changes in the Work or variations from the Contract Documents have been caused or are required as a result of any emergency. If PWC determines that a change in the Contract Documents is required because of the action taken by Contractor in response to such an emergency, a Work Change Directive or Change Order will be issued.

Section 7.13 Shop Drawings, Samples, and Other Submittals

- (a) Contractor shall timely submit Shop Drawings and Samples required by the Contract Documents to Project Engineer for review and approval in accordance with applicable specifications.
- (b) Before submitting a Shop Drawing or Sample, Contractor shall have
 - (i) reviewed the Shop Drawing or Sample with other Shop Drawings and Samples and with the requirements of the Work and the Contract Documents;
 - (ii) verified all measurements, quantities, dimensions, performance and design criteria, installation requirements, materials, catalog numbers, and similar information;
 - (iii) verified the suitability of all materials and equipment offered with respect to the indicated application, fabrication, shipping, handling, storage, assembly, and installation pertaining to the performance of the Work; and
 - (iv) verified all information relative to Contractor's responsibilities for means, methods, techniques, sequences, and procedures of construction, and safety precautions and programs incident thereto.
- (c) With each submittal, Contractor shall give Project Engineer specific written notice of any

General Conditions (Rev 7/11/2023)

variations that the Shop Drawing or Sample may have from the requirements of the Contract Documents. This notice shall be a written communication separate from the Shop Drawings or Sample submittal; and, in addition, in the case of Shop Drawings by a specific notation made on each Shop Drawing submitted to PWC for review and approval of each such variation.

- (d) Where a Shop Drawing or Sample is required by the Contract Documents, any related Work performed prior to Project Engineer's review and approval of the pertinent submittal will be at the sole expense and responsibility of Contractor.
- (e) Project Engineer will provide timely review of any required Shop Drawings and Samples. Such review, and subsequent determination of approval, will be only to determine if the items covered by the submittals will, after installation or incorporation in the Work, conform to the information given in the Contract Documents and be compatible with the design concept of the completed Project as a functioning whole as indicated by the Contract Documents.
- (f) Project Engineer's review and approval will not extend to means, methods, techniques, sequences, or procedures of construction or to safety precautions or programs incident thereto.
- (g) Project Engineer's review and approval of a Shop Drawing or Sample, or of a variation from the requirements of the Contract Documents, shall not change the Contract Times or Contract Price, unless such changes are included in a Change Order.
- (h) Project Engineer's receipt, review, acceptance or approval of a Shop Drawing, Sample, or other submittal shall not result in such item becoming a Contract Document.
- (i) Contractor shall perform the Work in compliance with the requirements and commitments set forth in approved Shop Drawings and Samples.
- (j) Resubmittal Procedures:
 - (i) Contractor shall make corrections required by Project Engineer and shall return the required number of corrected copies of Shop Drawings and submit new Samples as required for review and approval. Contractor shall direct specific attention in writing to revisions other than the corrections called for by PWC or Project Engineer on previous submittals.
 - (ii) Contractor shall furnish required submittals with sufficient information and accuracy to obtain required approval of an item with no more than three (3) submittals. If PWC has engaged a Design Engineer for the Project, Design Engineer will record Design Engineer's time for reviewing a fourth or subsequent submittal of a Shop Drawings, sample, or other item requiring approval, and Contractor shall be responsible for Design Engineer's charges to PWC for such time. PWC may impose a set-off against payments due to Contractor to secure reimbursement for such charges.
 - (iii) If Contractor requests a change of a previously approved submittal item, Contractor shall be responsible for Design Engineer's charges to PWC for its review time, and PWC may impose a set-off against payments due to Contractor to secure reimbursement for such charges, unless the need for such change is beyond the control of Contractor.

Section 7.14 Contractor's General Warranty and Guarantee

- (a) In order to induce PWC to enter into an Agreement with Contractor for the Project, Contractor warrants and guarantees to PWC that:
- (i) Contractor is duly licensed in the State of North Carolina to complete all Work necessary for the Project, is duly organized, validly existing and in good standing and has all requisite powers, rights, and authority to execute, enter into, and perform the Agreement in accordance with the terms and conditions of the Agreement, and the Agreement constitutes a legal, valid, and binding obligation of Contractor enforceable against it in accordance with its terms.
 - (ii) Contractor has read the Contract Documents, and acknowledges and understands all data, materials, specifications, and requirements identified in the Contract Documents.
 - (iii) Contractor has visited the site for the Project, conducted a thorough, visual examination of the site and adjacent areas, and become familiar with and is satisfied as to the general, local, and site conditions that may affect cost, progress, and performance in completing the Project.
 - (iv) Contractor is familiar with and is satisfied as to all laws and regulations that may affect cost, progress, and performance to complete the Project.
 - (v) Contractor has carefully studied all: (1) reports of explorations and tests of subsurface conditions at or adjacent to the site and all drawings of physical conditions relating to existing surface or subsurface structures at the site that have been identified in the Detail Specifications and any accompanying reports and drawings, and (2) reports and drawings relating to any Hazardous Environmental Condition at or adjacent to the site that have been identified in the Contract Documents and any accompanying reports and drawings.
 - (vi) Contractor has considered the information known to Contractor itself; information commonly known to contractors doing business in the locality of the Site; information and observations obtained from visits to the Site; the Contract Documents; and the Site-related reports and drawings identified in the Contract Documents, if any, with respect to the effect of such information, observations, and documents on (1) the cost, progress, and performance of the Work; (2) the means, methods, techniques, sequences, and procedures of construction to be employed by Contractor; and (3) Contractor's safety precautions and programs.
 - (vii) Based on the information and observations referred to in subsection "(v)" of this Section, Contractor agrees that no further examinations, investigations, explorations, tests, studies, or data are necessary for the performance of the Work at the Contract Price and in accordance with the other terms and conditions of the Contract Documents.
 - (viii) Contractor is aware of the general nature of work to be performed by PWC and others at the Site that relates to the Work as indicated in the Contract Documents.
 - (ix) Contractor has given PWC written notice of all conflicts, errors, ambiguities, or discrepancies that Contractor has discovered in the Contract Documents, and the written resolution thereof by PWC is acceptable to Contractor.
 - (x) The Contract Documents are generally sufficient to indicate and convey understanding of all terms and conditions for performance and furnishing of the Work.
 - (xi) Contractor's entry into this Agreement constitutes an incontrovertible representation by Contractor that, without exception, all prices in the Agreement are premised upon performing and furnishing the Work required by the Contract Documents.
 - (xii) Contractor has no business or personal relationship with any PWC Commissioner, officer, director, manager, or supervisor and Contractor covenants to disclose immediately to PWC any such relationship that develops during the performance of Work on the Project.

- (b) Contractor's obligation to perform and complete the Work in accordance with the Contract Documents shall be absolute. None of the following will constitute an acceptance of Work that is not in accordance with the Contract Documents or a release of Contractor's obligation to perform the Work in accordance with the Contract Documents:
 - (i) observations by Project Engineer;
 - (ii) recommendation by Project Engineer or payment by PWC of any progress or final payment;
 - (iii) the issuance of a certificate of Substantial Completion by Project Engineer or any payment related thereto by PWC;
 - (iv) use or occupancy of the Work or any part thereof by PWC;
 - (v) any review and approval of a Shop Drawing or Sample submittal;
 - (vi) the issuance of a notice of acceptability by Project Engineer;
 - (vii) any inspection, test, or approval by others; or
 - (viii) any correction of defective Work by PWC.

- (c) If the Contract Documents requires the Contractor to accept the assignment of a contract entered into by PWC, then the specific warranties, guarantees, and correction obligations contained in the assigned contract shall govern with respect to Contractor's performance obligations to PWC for the Work described in the assigned contract.

Section 7.15 Indemnification

- (a) Contractor shall indemnify, defend, and hold harmless PWC and its Commissioners, officers, employees, agents, and representatives and the City and its elected officials, managers, employees, agents, and representatives and Designer (collectively "Indemnitees") from and against all claims, actions, liabilities, damages, losses, costs, and expenses (including, without limitation, injury to or death of any persons and damage to property, economic and consequential damages and attorneys' fees) asserted by one or more third parties against one or more of the Indemnitees if the Fault of one or more Responsible Persons is a proximate cause of the loss, damage, or expense indemnified.

- (b) Contractor's obligation to indemnify, defend, and hold harmless the Indemnitees shall survive the termination of the Agreement.

- (c) In any and all claims against the Indemnitees of Contractor, any Subcontractor, any Supplier, or any individual or entity directly or indirectly employed by any of them to perform any of the Work, or anyone for whose acts any of them may be liable, Contractor's indemnification obligation shall not be limited in any way by any limitation on the amount or type of damages, compensation, or benefits payable by or for Contractor or any such Subcontractor, Supplier, or other individual or entity under workers' compensation acts, disability benefit acts, or other employee benefit acts.

Section 7.16 Claims Procedure

- (a) PWC shall notify the Contractor of all potential claims related to the Work within seven (7) calendar days of receiving notification or having knowledge of such potential claim. Should the Contractor receive a potential claim related to the Work, the Contractor shall notify PWC within seven (7) calendar days of receiving notification. The Contractor shall provide the claimant and PWC with a written response acknowledging receipt of the claim within

seven (7) calendar days.

- (b) If the Contractor meets with the Claimant about the claim, a representative designated by PWC shall be present at all times. PWC shall maintain a record of any claim received, and the steps taken to resolve. PWC shall also concurrently investigate each case. The Contractor agrees to furnish PWC any information regarding the claim, the actions which led to the claim and/or the investigation of the claim. Contractor shall provide their proposed response to PWC within thirty (30) calendar days of receiving the claim. Upon receipt of the response PWC and the Contractor will discuss and reach a mutual agreement of the response necessary to send to the Claimant within fifteen (15) calendar days. Once the agreement is made the Contractor shall make a formal written resolution to the claimant.
- (c) Failure to act in good faith or respond to a claim in the timelines established by the Contract Documents will constitute a lack of response by the Contractor, therefore validating the claim. PWC will deduct the total amount of the claim from the monthly pay application. Failure to comply with the above requirements for resolving claims may, at the sole discretion of PWC, result in breach of contract.
- (d) The Contractor is aware of these claims procedures and understands that it is the PWC's practice to pursue reimbursement/subrogation for any and all claims related expenses, which are incurred as a result of the Contractor's performance under this Contract Documents and allowed within the applicable statute of limitations.

Section 7.17 Delegation of Professional Design Services

- (a) Contractor will not be required to provide professional design services unless such services are specifically required by the Contract Documents for a portion of the Work or unless such services are required to carry out Contractor's responsibilities for construction means, methods, techniques, sequences and procedures. Contractor shall not be required to provide professional services in violation of applicable Laws and Regulations.
- (b) If professional design services or certifications by a design professional related to systems, materials, or equipment are specifically required of Contractor by the Contract Documents, PWC will specify all performance and design criteria that such services must satisfy. Contractor shall cause such services or certifications to be provided by a properly licensed professional, whose signature and seal shall appear on all drawings, calculations, specifications, certifications, and other submittals prepared by such professional. Shop Drawings and other submittals related to the Work designed or certified by such professional, if prepared by others, shall bear such professional's written approval when submitted to PWC.
- (c) PWC shall be entitled to rely upon the adequacy, accuracy, and completeness of the services, certifications, or approvals performed by such design professionals, provided PWC has specified to Contractor all performance and design criteria that such services must satisfy.
- (d) Pursuant to this Section, PWC's, or its designee's, review and approval of design calculations and design drawings will be only for the limited purpose of checking for conformance with performance and design criteria given and the design concept expressed in the Contract Documents. PWC specifically retains final approval of such

submittals.

- (e) Contractor shall not be responsible for the adequacy of the performance or design criteria specified by PWC.

Article VIII. PWC's Responsibilities

- (a) In awarding the bid to Contractor and executing the applicable Agreement, PWC acknowledges the following responsibilities:
 - (i) Except as otherwise provided in these General Conditions, PWC shall issue all communications directly to Contractor or its designee.
 - (ii) PWC may at its discretion replace Design Engineer and Project Engineer. The replacement Design Engineer or Project Engineer's status under the Contract Documents shall be that of the former Design Engineer or Project Engineer.
 - (iii) PWC shall promptly furnish the data required of PWC under the Contract Documents.
 - (iv) PWC shall make payments to Contractor when they are due as provided in the Contract Documents.
 - (v) PWC shall not supervise, direct, or have control or authority over, nor be responsible for, Contractor's means, methods, techniques, sequences, or procedures of construction, or the safety precautions and programs incident thereto, or for any failure of Contractor to comply with Laws and Regulations applicable to the performance of the Work. PWC will not be responsible for Contractor's failure to perform the Work in accordance with the Contract Documents.
 - (vi) Upon request of Contractor, PWC shall furnish to Contractor reasonable evidence that financial arrangements have been made to satisfy PWC's obligations under the Contract Documents (including obligations under proposed changes in the Work).
 - (vii) While at the Site, PWC's employees and representatives shall comply with the specific applicable requirements of Contractor's safety programs of which PWC has been informed.
 - (viii) PWC shall furnish copies of any applicable PWC safety program(s) to Contractor, which Contractor shall review and implement.

Article IX. Amending the Contract Documents; Changes in the Work

Section 9.01 Amending and Supplementing Contract Documents

- (a) The Contract Documents may be amended or supplemented by a Change Order, a Work Change Directive, or a Field Order.
 - (i) Change Orders: If an amendment or supplement to the Contract Documents includes a change in the Contract Price or the Contract Times, such amendment or supplement must be set forth in a Change Order. A Change Order also may be used to establish amendments and supplements of the Contract Documents that do not affect the Contract Price or Contract Times.
 - (ii) Work Change Directives: A Work Change Directive will not change the Contract Price or the Contract Times, but is evidence that the parties expect that the modification ordered or documented by a Work Change Directive will be incorporated in a subsequently issued Change Order, following negotiations by the parties as to the Work Change Directive's effect, if any, on the Contract Price and Contract Times; or, if negotiations are

unsuccessful, by a determination under the terms of the Contract Documents governing adjustments, expressly including Paragraph 9.04 regarding change of Contract Price. Contractor must submit any Change Proposal seeking an adjustment of the Contract Price or the Contract Times, or both, no later than 30 days after the completion of the Work set out in the Work Change Directive. PWC must submit any dispute or request seeking an adjustment of the Contract Price or the Contract Times, or both, no later than 60 days after issuance of the Work Change Directive.

- (iii) Field Orders: Project Engineer may authorize minor changes in the Work if the changes do not involve an adjustment in the Contract Price or the Contract Times and are compatible with the design concept of the completed Project as a functioning whole as indicated by the Contract Documents. Such changes will be accomplished by a Field Order and will be binding on PWC and on Contractor, which shall perform promptly the Work involved. If Contractor believes that a Field Order justifies an adjustment in the Contract Price or Contract Times, or both, then before proceeding with the Work at issue, Contractor shall submit a Change Proposal as provided herein.

Section 9.02 PWC-Authorized Changes in the Work

- (a) Without invalidating the Agreement and without notice to any surety, PWC may, at any time or from time to time, order additions, deletions, or revisions in the Work. Such changes shall be supported by Design Engineer's recommendation when applicable and to the extent the change involves the design (as set forth in the Drawings, Specifications, or otherwise), or other engineering or technical matters. Such changes may be accomplished by a Change Order or by a Work Change Directive. Upon receipt of any such document, Contractor shall promptly proceed with the Work as revised. Nothing in this paragraph shall obligate Contractor to undertake work that Contractor reasonably concludes cannot be performed in a manner consistent with Contractor's safety obligations under the Contract Documents or Laws and Regulations.

Section 9.03 Unauthorized Changes in the Work

- (a) Contractor shall not be entitled to an increase in the Contract Price or an extension of the Contract Times with respect to any work performed that is not required by the Contract Documents, as amended, modified, or supplemented.

Section 9.04 Change of Contract Price

- (a) The Contract Price may only be changed by a Change Order. Any Change Proposal for an adjustment in the Contract Price shall comply with the provisions of these General Conditions.
- (b) An adjustment in the Contract Price will be determined as follows:
 - (i) where the Work involved is covered by unit prices contained in the Contract Documents, then by application of such unit prices to the quantities of the items involved; or
 - (ii) where the Work involved is not covered by unit prices contained in the Contract Documents, then by a mutually agreed lump sum (which may include an allowance for overhead and profit as agreed to in writing by the Parties); or
 - (iii) where the Work involved is not covered by unit prices contained in the Contract Documents and the Parties do not reach mutual agreement to a lump sum, then on the basis of the Cost of the Work plus a reasonable Contractor's fee for overhead and profit.

- (c) Contractor's Fee: When applicable, the Contractor's fee for overhead and profit shall be determined as follows:
 - (i) a mutually acceptable fixed fee; or
 - (ii) if a fixed fee is not agreed upon, then a fee based on the following percentages of the various portions of the Cost of the Work:
 - 1) for unit prices, the Contractor's fee shall be fifteen percent (15%);
 - 2) for all other costs incurred, the Contractor's fee shall be five percent (5%);
 - 3) the amount of credit to be allowed by Contractor to PWC for any change that results in a net decrease in the Contract Price will be the amount of the actual net decrease in cost plus a deduction in Contractor's fee by an amount equal to five percent of such net decrease; and
 - 4) when both additions and credits are involved in any one change, the adjustment in Contractor's fee shall be computed on the basis of the net change.

Section 9.05 Change of Contract Times

- (a) The Contract Times may only be changed by a Change Order. Any Change Proposal for an adjustment in the Contract Times shall comply with the provisions of Paragraph 9.06.
- (b) An adjustment of the Contract Times shall be subject to the limitations set forth in these Contract Documents as it concerns delays in Contractor's progress.

Section 9.06 Change Proposals

- (a) Contractor shall submit a Change Proposal to PWC to request an adjustment in the Contract Times and/or Contract Price. The Change Proposal shall specify any proposed change in Contract Times or Contract Price, or both, or other proposed relief, and explain the reason for the proposed change, with citations to any governing or applicable provisions of the Contract Documents.
 - (i) Procedures: Contractor shall submit each Change Proposal to PWC promptly (but in no event later than 30 days) after the start of the event giving rise thereto, or after such initial decision. The Contractor shall submit supporting data, including the proposed change in Contract Price or Contract Time (if any), to PWC within 15 calendar days after the submittal of the Change Proposal. The supporting data shall be accompanied by a written statement that the supporting data are accurate and complete, and that any requested time or price adjustment is the entire adjustment to which Contractor believes it is entitled as a result of said event.
 - (ii) PWC Action: PWC will review each Change Proposal and, within 30 calendar days after receipt of the Contractor's supporting data, either deny the Change Proposal in whole, approve it in whole, or deny it in part and approve it in part. Such actions shall be in writing to Contractor. If PWC does not take action on the Change Proposal within 30 calendar days, then the Change Proposal is deemed denied, thereby commencing the time for appeal under these General Conditions.
 - (iii) Binding Decision: PWC's decision will be final and binding unless Contractor appeals the decision.

Section 9.07 Execution of Change Orders

- (a) PWC and Contractor shall execute appropriate Change Orders covering:
 - (i) changes in the Contract Price or Contract Times that are agreed to by the parties, including any undisputed sum or amount of time for Work performed in accordance with a Work Change Directive;
 - (ii) changes in Contract Price resulting from a PWC set-off, unless Contractor has duly contested such set-off;
 - (iii) changes in the Work which are: (a) ordered by PWC, (b) required because of PWC's acceptance of defective Work or PWC's correction of defective Work, or (c) agreed to by the parties, subject to the need for Design Engineer's recommendation if the change in the Work involves the design (as set forth in the Contract Documents), or other engineering or technical matters; and
 - (iv) changes in the Contract Price or Contract Times, or other changes, which embody the substance of any final and binding results.
- (b) If PWC or Contractor refuses to execute a Change Order that is required to be executed under the terms of this Section, it shall be deemed to be of full force and effect as if fully executed.

Section 9.08 Notification to Surety

- (a) If the provisions of any bond require notice to be given to a surety of any change affecting the general scope of the Work or the provisions of the Contract Documents (including, but not limited to, Contract Price or Contract Times), the giving of any such notice will be Contractor's responsibility. The amount of each applicable bond will be adjusted to reflect the effect of any such change.

Article X. Tests, Inspections, and Approvals; Correction, Removal, or Acceptance of Defective Work

Section 10.01 Access to Work

- (a) PWC, Design Engineer, their consultants and other representatives and personnel of PWC, independent testing laboratories, and authorities having jurisdiction will have access to the Site and the Work at reasonable times for their observation, inspection, and testing. Contractor shall provide them proper and safe conditions for such access and advise them of Contractor's safety procedures and programs so that they may comply therewith as applicable.

Section 10.02 Tests, Inspections, and Approvals

- (a) Contractor shall give Project Engineer timely notice of readiness of the Work (or specific parts thereof) for all required inspections and tests and shall cooperate with inspection and testing personnel to facilitate required inspections and tests.
- (b) PWC shall retain and pay for the initial services of an independent inspector, testing laboratory, or other qualified individual or entity to perform all inspections and tests expressly required by the Contract Documents to be furnished and paid for by PWC, except those costs incurred in connection with tests or inspections of covered Work shall

be governed by the provisions of Paragraph 10.05.

- (c) If Laws or Regulations of any public body having jurisdiction require any Work (or part thereof) specifically to be inspected, tested, or approved by an employee or other representative of such public body, Contractor shall assume full responsibility for arranging and obtaining such inspections, tests, or approvals, pay all costs in connection therewith, and furnish the required certificates of inspection or approval to PWC.
- (d) Contractor shall be responsible for arranging, obtaining, and paying for all inspections and tests required:
 - (i) by the Contract Documents, unless the Contract Documents expressly allocate responsibility for a specific inspection or test to PWC;
 - (ii) to attain PWC's and Design Engineer's acceptance of materials or equipment to be incorporated in the Work;
 - (iii) by manufacturers of equipment furnished under the Contract Documents;
 - (iv) for testing, adjusting, and balancing of mechanical, electrical, and other equipment to be incorporated into the Work; and
 - (v) for acceptance of materials, mix designs, or equipment submitted for approval prior to Contractor's purchase thereof for incorporation in the Work.

Such inspections and tests shall be performed by independent inspectors, testing laboratories, or other qualified individuals or entities acceptable to PWC, as confirmed in writing by Project Engineer to Contractor.

- (e) If the Contract Documents require the Work (or part thereof) to be approved by PWC or its designee, then Contractor shall assume full responsibility for arranging and obtaining such approvals.
- (f) If any Work (or the work of others) that is to be inspected, tested, or approved is covered by Contractor without written concurrence of Project Engineer, Contractor shall, if requested by Project Engineer, uncover such Work for observation. Such uncovering shall be at Contractor's expense unless Contractor had given PWC timely notice of Contractor's intention to cover the same and PWC had not acted with reasonable promptness in response to such notice.

Section 10.03 Defective Work

- (a) It is Contractor's obligation to assure that the Work is not defective.
- (b) PWC or its designee has the authority to determine whether Work is defective, and to reject defective Work.
- (c) Prompt notice of all defective Work of which PWC has actual knowledge will be given to Contractor.
- (d) Promptly after receipt of written notice of defective Work, Contractor shall correct all such defective Work, whether or not fabricated, installed, or completed, or, if PWC has rejected the defective Work, remove it from the Project and replace it with Work that is not defective.

General Conditions (Rev 7/11/2023)

- (e) When correcting defective Work, Contractor shall take no action that would void or otherwise impair PWC's special warranty and guarantee, if any, on said Work.
- (f) In addition to its correction, removal, and replacement obligations with respect to defective Work, Contractor shall pay all claims, costs, losses, and damages arising out of or relating to defective Work, including but not limited to the cost of the inspection, testing, correction, removal, replacement, or reconstruction of such defective Work, fines levied against PWC by governmental authorities because the Work is defective, and the costs of repair or replacement of work of others resulting from defective Work. Prior to final payment, if PWC and Contractor are unable to agree as to the measure of such claims, costs, losses, and damages resulting from defective Work, then PWC may impose a reasonable set-off against payments due.

Section 10.04 Acceptance of Defective Work

- (a) If, instead of requiring correction or removal and replacement of defective Work, PWC prefers to accept it, PWC may do so (subject, if such acceptance occurs prior to final payment, to Design Engineer's confirmation that such acceptance is in general accord with the design intent and applicable engineering principles and will not endanger public safety).
- (b) Contractor shall pay all claims, costs, losses, and damages attributable to PWC's evaluation of and determination to accept such defective Work (such costs to be approved by PWC as to reasonableness), and for the diminished value of the Work to the extent not otherwise paid by Contractor. If any such acceptance occurs prior to final payment, the necessary revisions in the Contract Documents with respect to the Work shall be incorporated in a Change Order.
- (c) If the parties are unable to agree as to the decrease in the Contract Price, reflecting the diminished value of Work so accepted, then PWC may impose a reasonable set-off against payments due. If the acceptance of defective Work occurs after final payment, Contractor shall pay an appropriate amount to PWC.

Section 10.05 Uncovering Work

- (a) PWC has discretion to require, at its initial cost, additional inspection or testing of the Work, whether or not the Work is fabricated, installed, or completed.
- (b) If any Work is covered contrary to the written request of PWC, then Contractor shall, if requested by PWC or its designee, uncover such Work for observation, and then replace the covering, all at Contractor's expense.
- (c) If PWC considers it necessary or advisable that covered Work be observed by PWC or inspected or tested by others, then Contractor, at PWC's request, shall uncover, expose, or otherwise make available for observation, inspection, or testing as PWC may require, that portion of the Work in question, and provide all necessary labor, material, and equipment.
 - (i) If it is found that the uncovered Work is defective, Contractor shall be responsible for all claims, costs, losses, and damages arising out of or relating to such uncovering, exposure, observation, inspection, and testing, and of satisfactory replacement or reconstruction (including but not limited to all costs of repair or replacement of work of others); and pending Contractor's full discharge of this responsibility PWC shall be entitled to impose a reasonable set-off against payments due.

General Conditions (Rev 7/11/2023)

- (ii) If the uncovered Work is not found to be defective, Contractor shall be allowed an increase in the Contract Price or an extension of the Contract Times, or both, directly attributable to such uncovering, exposure, observation, inspection, testing, replacement, and reconstruction. If the parties are unable to agree as to the amount or extent thereof, then Contractor may submit a Change Proposal within 30 calendar days of the determination that the Work is not defective.

Section 10.06 PWC May Stop the Work

- (a) If the Work is defective, or Contractor fails to supply sufficiently skilled workers or suitable materials or equipment, or fails to perform the Work in such a way that the completed Work will conform to the Contract Documents, then PWC may order Contractor to stop the Work, or any portion thereof, until the cause for such order has been eliminated; however, this right of PWC to stop the Work shall not give rise to any duty on the part of PWC to exercise this right for the benefit of Contractor, any Subcontractor, any Supplier, any other individual or entity, or any surety for, or employee or agent of any of them.

Section 10.07 PWC May Correct Defective Work

- (a) If Contractor fails within the time specified by PWC in a written notice from PWC to correct defective Work, or to remove and replace rejected Work as required by PWC, or if Contractor fails to perform the Work in accordance with the Contract Documents, or if Contractor fails to comply with any other provision of the Contract Documents, then PWC may, after seven (7) calendar days written notice to Contractor, correct or remedy any such deficiency.
- (b) In exercising the rights and remedies under this Section, PWC shall proceed expeditiously. In connection with such corrective or remedial action, PWC may exclude Contractor from all or part of the Site, take possession of all or part of the Work and suspend Contractor's services related thereto, and incorporate in the Work all materials and equipment stored at the Site or for which PWC has paid Contractor but which are stored elsewhere. Contractor shall allow PWC and its officers, employees, representatives, agents and other contractors, and Design Engineer and its employees and agents access to the Site to enable PWC to exercise the rights and remedies under this Section.
- (c) All claims, costs, losses, and damages incurred or sustained by PWC in exercising the rights and remedies under this Section will be charged against Contractor as set-offs against payments due. Such claims, costs, losses and damages will include but not be limited to all costs of repair, or replacement of work of others destroyed or damaged by correction, removal, or replacement of Contractor's defective Work.
- (d) Contractor shall not be allowed an extension of the Contract Times because of any delay in the performance of the Work attributable to the exercise by PWC of PWC's rights and remedies under this Section.

Article XI. Claims

Section 11.01 Claims Process

- (a) The following disputes between PWC and Contractor shall be submitted to the Claims process set forth in this Article:

- (i) Appeals by PWC or Contractor of Design Engineer's decisions regarding Change Proposals;
- (ii) PWC or Contractor's demands for adjustments in the Contract Price or Contract Times, or other relief under the Contract Documents; and
- (iii) Disputes that Design Engineer has been unable to address because they do not involve the design (as set forth in the Contract Documents), the acceptability of the Work, or other engineering or technical matters.

Section 11.02 Submittal of Claim

- (a) The party submitting a claim shall deliver it directly to the other party to the Agreement promptly (but in no event later than 30 calendar days) after the start of the event giving rise thereto; in the case of appeals regarding Change Proposals within 30 calendar days of the decision under appeal. The responsibility to substantiate a claim shall rest with the party making the claim. In the case of a claim by Contractor seeking an increase in the Contract Times or Contract Price, or both, Contractor shall certify that the claim is made in good faith, that the supporting data are accurate and complete, and that to the best of Contractor's knowledge and belief the amount of time or money requested accurately reflects the full amount to which Contractor is entitled.

Section 11.03 Review and Resolution

- (a) The party receiving a Claim shall review it thoroughly, giving full consideration to its merits. The two parties shall seek to resolve the Claim through the exchange of information and direct negotiations. The parties may extend the time for resolving the Claim by mutual agreement. All actions taken on a Claim shall be stated in writing and submitted to the other party.

Section 11.04 Dispute Resolution

- (a) In the event of any dispute, controversy, or claim of any kind or nature arising under or in connection with this Agreement (a "Dispute") and involving any two or more of the following parties, PWC, Design Engineer, Contractor or any subcontractor of Contractor, the party initiating the Dispute shall serve written notice of a Dispute on the party(ies) to the dispute, and those parties shall endeavor to settle the dispute first through direct, informal discussions between the parties' selected representatives. Any such representative(s) shall have binding authority to settle the Dispute. In the event the parties do not settle the Dispute within ten (10) calendar days from the date of written notice of the Dispute, any party to the Dispute may, by written notice to the other party(ies), engage a mediator certified under the laws of the State of North Carolina to mediate the Dispute within thirty (30) calendar days of such notice. The parties to the Dispute shall attend mediation in good faith. In the event mediation is unsuccessful, any party to the dispute may initiate arbitration proceedings. Any controversy or claim arising out of or relating to the Contract Documents, or the breach thereof, shall be settled by binding arbitration administered by the American Arbitration Association under its Construction Industry Arbitration Rules, and judgment on the award rendered by the arbitrator(s) may be entered in any court having jurisdiction thereof. All of the foregoing dispute resolution procedures shall be held in Cumberland County, North Carolina. The costs of the mediator and arbitrator in a dispute resolution process shall be divided equally among the parties to the process; provided, however, PWC shall bear at least one-third of the cost if PWC is a party to the dispute resolution and the remainder of the cost shall be divided equally among the other parties

participating in the dispute resolution. PWC shall, in its contractual arrangements with Design Engineer, and Contractor shall, in its contracts with Subcontractors and they in their contracts with lower-tier subcontractors authorize and direct such parties to participate in the dispute resolution procedures set forth in this Section. Unless otherwise directed in writing by PWC, Contractor shall continue the Project and maintain compliance with the scheduling deadlines set forth in the Contract Documents during any dispute resolution proceedings. If Contractor continues to perform, PWC shall make payments due for the continued performance in accordance with this Agreement. The provisions of this Section shall not extend any applicable statutes of limitation or repose.

Article XII. Payments to Contractor; Set-Offs; Completion; Correction Period

Section 12.01 Progress Payments

- (a) The Schedule of Values will serve as the basis for progress payments and will be incorporated into a form of Application for Payment acceptable to the Project Engineer. Progress payments on account of Unit Price Work will be based on the number of units completed during the pay period. Progress payments for cost-based Work will be based on the Cost of the Work completed by the Contractor during the pay period.
- (b) Applications for Payments:
 - (i) Contractor shall submit to Project Engineer for review an Application for Payment filled out and signed by Contractor covering the Work completed as of the date of the Application and accompanied by such supporting documentation as is required by the Contract Documents. If payment is requested on the basis of materials and equipment not incorporated in the Work but delivered and suitably stored at the Site or another location agreed to in writing, the Application for Payment shall also be accompanied by a bill of sale, invoice, or other documentation warranting that PWC has received the materials and equipment free and clear, and evidence that the materials and equipment are covered by appropriate property insurance, a warehouse bond, or other arrangements to protect PWC's interest.
 - (ii) Beginning with the second Application for Payment, each Application shall include an affidavit of Contractor stating that all previous progress payments received on account of the Work have been applied on account to discharge Contractor's legitimate obligations associated with prior Applications for Payment.
 - (iii) The amount of retainage for progress payments will be as stipulated in the Contract Documents.
- (c) Review of Applications:
 - (i) Project Engineer will, within ten (10) Business Days after receipt of each Application for Payment, including each resubmittal, either indicate in writing a recommendation of payment and present the Application to PWC, or return the Application to Contractor indicating in writing Project Engineer's reason(s) for refusing to recommend payment. In the latter case, the Contractor may make the necessary corrections and resubmit the Application.
 - (ii) Project Engineer's recommendation of any payment requested in an Application for Payment will constitute a representation by Project Engineer to PWC, based on Project Engineer's observations of the executed Work, and on Project Engineer's review of the

General Conditions (Rev 7/11/2023)

Application for Payment and the accompanying data and schedules, that to the best of Project Engineer's knowledge, information, and belief:

- 1) the Work has progressed to the point indicated;
 - 2) the quality of the Work is generally in accordance with the Contract Documents (subject to an evaluation of the Work as a functioning whole prior to or upon Substantial Completion, the results of any subsequent tests called for in the Contract Documents, a final determination of quantities and classifications for Unit Price Work, and any other qualifications stated in the recommendation); and
 - 3) the conditions precedent to Contractor's being entitled to such payment appear to have been fulfilled in so far as it is Project Engineer's responsibility to observe the Work.
- (iii) By recommending any such payment Project Engineer will not thereby be deemed to have represented that:
- 1) inspections made to check the quality or the quantity of the Work as it has been performed have been exhaustive, extended to every aspect of the Work in progress, or involved detailed inspections of the Work beyond the responsibilities specifically assigned to Project Engineer in the Contract Documents; or
 - 2) there may not be other matters or issues between the parties that might entitle Contractor to be paid additionally by PWC or entitle PWC to withhold payment to Contractor.
- (iv) Neither Project Engineer's review of Contractor's Work for the purposes of recommending payments nor Project Engineer's recommendation of any payment, including final payment, will impose responsibility on Project Engineer:
- 1) to supervise, direct, or control the Work, or
 - 2) for the means, methods, techniques, sequences, or procedures of construction, or the safety precautions and programs incident thereto, or
 - 3) for Contractor's failure to comply with Laws and Regulations applicable to Contractor's performance of the Work, or
 - 4) to make any examination to ascertain how or for what purposes Contractor has used the money paid on account of the Contract Price.
- (v) Project Engineer may refuse to recommend the whole or any part of any payment if, in Project Engineer's opinion, it would be incorrect to make the representations to PWC outlined in this Section.
- (d) Project Engineer will recommend reductions in payment (set-offs) necessary in Project Engineer's opinion to protect PWC from loss because:
- (i) the Work is defective, requiring correction or replacement;
 - (ii) the Contract Price has been reduced by Change Orders;
 - (iii) PWC has been required to correct defective Work or has accepted defective Work in accordance with these General Conditions;
 - (iv) PWC has been required to remove or remediate a Hazardous Environmental Condition for which Contractor is responsible; or
 - (v) Project Engineer has actual knowledge of the occurrence of any of the events that would constitute a default by Contractor and therefore justify termination for cause under the Contract Documents.

(e) Payment Becomes Due:

- (i) Twenty (20) Business Days after presentation of the Application for Payment to PWC with Project Engineer's recommendation, the amount recommended (subject to any PWC set offs) will become due, and when due will be paid by PWC to Contractor.

(f) Reductions in Payment by PWC:

- (i) In addition to any reductions in payment (set-offs) recommended by Project Engineer, PWC is entitled to impose a set-off against payment based on any of the following:

- 1) PWC has incurred costs, losses, or damages on account of Contractor's conduct in the performance or furnishing of the Work, including but not limited to claims, costs, losses, or damages from workplace injuries, adjacent property damage, non-compliance with Laws and Regulations, and patent infringement;
- 2) Contractor has failed to take reasonable and customary measures to avoid damage, delay, disruption, and interference with other work at or adjacent to the Site;
- 3) Contractor has failed to provide and maintain required bonds or insurance;
- 4) PWC has been required to remove or remediate a Hazardous Environmental Condition for which Contractor is responsible;
- 5) PWC has incurred extra charges or engineering costs related to submittal reviews, evaluations of proposed substitutes, tests and inspections, or return visits to manufacturing or assembly facilities;
- 6) the Work is defective, requiring correction or replacement;
- 7) PWC has been required to correct defective Work or has accepted defective Work in accordance with the Contract Documents;
- 8) the Contract Price has been reduced by Change Orders;
- 9) an event that would constitute a default by Contractor and therefore justify a termination for cause has occurred;
- 10) liquidated damages have accrued as a result of Contractor's failure to achieve Milestones, Substantial Completion, or Completion of the Project; or
- 11) there are other items entitling PWC to a set off against the amount recommended.

- (ii) If PWC imposes any set-off against payment, whether based on its own knowledge or on the written recommendations of Project Engineer, PWC will give Contractor immediate written notice stating the reasons for such action and the specific amount of the reduction, and promptly pay Contractor any amount remaining after deduction of the amount so withheld. PWC shall promptly pay Contractor the amount so withheld, or any adjustment agreed to by PWC and Contractor if Contractor remedies the reasons for such action. The reduction imposed shall be binding on Contractor unless it duly submits a Change Proposal contesting the reduction.

- (iii) Upon a subsequent determination that PWC's refusal of payment was not justified, the amount wrongfully withheld shall be treated as an amount due and subject to interest as provided in the Contract Documents.

Section 12.02 Substantial Completion

- (a) When Contractor considers the entire Work ready for its intended use Contractor shall notify PWC and Design Engineer in writing that the entire Work is substantially complete and request that PWC acknowledge in writing that Contractor has met Substantial Completion.

- (b) Promptly after Contractor's notification, PWC, Contractor, and Design Engineer shall make an inspection of the Work to determine the status of completion. If PWC does not consider the Work substantially complete, PWC will notify Contractor in writing giving the reasons therefor. PWC shall thereafter submit to Contractor an initial draft of punch list items to be completed or corrected before final payment.
- (c) If Design Engineer considers the Work substantially complete, Design Engineer will deliver to PWC a preliminary certificate of Substantial Completion which shall fix the date of Substantial Completion. Design Engineer shall attach to the certificate a punch list of items to be completed or corrected before final payment. PWC shall have seven (7) Business Days after receipt of the preliminary certificate to make written objection to Design Engineer as to any provisions of the certificate or attached punch list. If, after considering the objections to the provisions of the preliminary certificate, PWC concludes that the Work is not substantially complete, PWC will, within fourteen (14) calendar days after submission of the preliminary certificate to PWC, notify Contractor in writing that the Work is not substantially complete, stating the reasons therefor.
- (d) At the time of receipt of the preliminary certificate of Substantial Completion, PWC and Contractor will confer regarding PWC's use or occupancy of the Work following Substantial Completion, review the builder's risk insurance policy with respect to the end of the builder's risk coverage, and confirm the transition to coverage of the Work under a permanent property insurance policy held by PWC. Unless PWC and Contractor agree otherwise in writing, PWC shall bear responsibility for security, operation, protection of the Work, property insurance, maintenance, heat, and utilities upon PWC use or occupancy of the Work.
- (e) After Substantial Completion the Contractor shall promptly begin work on the punch list of items to be completed or corrected prior to final payment and shall complete such items within the time specified by PWC. In appropriate cases Contractor may submit monthly Applications for Payment for completed punch list items, following the progress payment procedures set forth above.
- (f) PWC shall have the right to exclude Contractor from the Site after the date of Substantial Completion subject to allowing Contractor reasonable access to remove its property and complete or correct items on the punch list.

Section 12.03 Partial Use or Occupancy

- (a) Prior to Substantial Completion of all the Work, PWC may use or occupy any substantially completed part of the Work which has specifically been identified in the Contract Documents, or which PWC, Design Engineer, and Contractor agree constitutes a separately functioning and usable part of the Work that can be used by PWC for its intended purpose without significant interference with Contractor's performance of the remainder of the Work, subject to the following conditions:
 - (i) At any time PWC may request in writing that Contractor permit PWC to use or occupy any such part of the Work that PWC believes to be substantially complete.
 - (ii) At any time Contractor may notify PWC and Design Engineer in writing that Contractor considers any such part of the Work substantially complete and request Design Engineer

General Conditions (Rev 7/11/2023)

to issue a certificate of Substantial Completion for that part of the Work.

- (iii) Within a reasonable time after either such request, PWC, Contractor, and Design Engineer shall make an inspection of that part of the Work to determine its status of completion. If Design Engineer does not consider that part of the Work to be substantially complete, Design Engineer will notify PWC and Contractor in writing giving the reasons therefor.
- (iv) No use or occupancy or separate operation of part of the Work may occur prior to compliance with the requirements regarding builder's risk or other property insurance.

Section 12.04 Final Inspection

- (a) Upon written notice from Contractor that Completion of the Project has been achieved or an agreed portion thereof is complete, PWC will promptly make a final inspection with Project Engineer, Design Engineer, and Contractor and will notify Contractor in writing of all particulars in which this inspection reveals that the Work, or agreed portion thereof, is incomplete or defective. Contractor shall immediately take such measures as are necessary to complete such Work or remedy such deficiencies.

Section 12.05 Final Payment

- (a) Application for Payment:
 - (i) After Contractor has, in the opinion of PWC, satisfactorily completed all corrections identified during the final inspection and has delivered, in accordance with the Contract Documents, all maintenance and operating instructions, schedules, guarantees, bonds, certificates or other evidence of insurance, certificates of inspection, annotated record documents, and other documents, Contractor may make application for final payment.
 - (ii) The final Application for Payment shall be accompanied (except as previously delivered) by:
 - 1) all documentation called for in the Contract Documents;
 - 2) consent of the surety, if any, to final payment;
 - 3) satisfactory evidence that all title issues have been resolved such that title to all Work, materials, and equipment has passed to PWC free and clear or will so pass upon final payment;
 - 4) a list of all disputes that Contractor believes are unsettled; and
 - 5) complete and legally effective releases or waivers (satisfactory to PWC) required by the Contract Documents.
 - (iii) If Design Engineer is satisfied that the Work has been completed and Contractor's other obligations under the Contract have been fulfilled, Design Engineer will, within ten (10) Business Days after receipt of the final Application for Payment, indicate in writing Design Engineer's recommendation of final payment and present the Application for Payment to PWC for payment. Such recommendation shall account for any set-offs against payment that are necessary in Design Engineer's opinion to protect PWC from loss for the reasons stated above with respect to progress payments. At the same time Design Engineer will also give written notice to PWC and Contractor that the Work is acceptable and that Completion of the Project has been achieved. Otherwise, Design Engineer will return the Application for Payment to Contractor, indicating in writing the reasons for refusing to recommend final payment, in which case Contractor shall make the necessary corrections and resubmit the Application for Payment.
 - (iv) Within thirty (30) calendar days after the presentation to PWC of the final Application for

General Conditions (Rev 7/11/2023)

Payment and accompanying documentation, the amount recommended by Design Engineer (less any further sum PWC is entitled to set off against Design Engineer's recommendation, including but not limited to set-offs for liquidated damages and set-offs allowed under the provisions above with respect to progress payments) will become due and shall be paid by PWC to Contractor.

Section 12.06 Waiver of Claims

- (a) The making of final payment will not constitute a waiver by PWC of claims or rights against Contractor. PWC expressly reserves claims and rights arising from defective Work appearing after final inspection, from Contractor's failure to comply with the Contract Documents or the terms of any special guarantees specified therein, from Contractor's indemnification obligations, or from Contractor's continuing obligations under the Contract Documents.
- (b) The acceptance of final payment by Contractor will constitute a waiver by Contractor of all claims and rights against PWC other than those pending matters that have been duly submitted or appealed under the provisions of the Contract Documents.

Section 12.07 Correction Period

- (a) If within one (1) year after the date of Substantial Completion (or such longer period of time as may be prescribed by the terms of any applicable special guarantee required by the Contract Documents, or by any specific provision of the Contract Documents), any Work is found to be defective, or if the repair of any damages to the Site, adjacent areas that Contractor has arranged to use through construction easements or otherwise, and other adjacent areas used by Contractor as permitted by Laws and Regulations, is found to be defective, then Contractor shall promptly, without cost to PWC and in accordance with PWC's written instructions:
 - (i) correct the defective repairs to the Site or such other adjacent areas;
 - (ii) correct such defective Work;
 - (iii) if the defective Work has been rejected by PWC, remove it from the Project and replace it with Work that is not defective, and
 - (iv) satisfactorily correct or repair or remove and replace any damage to other Work, to the work of others, or to other land or areas resulting therefrom.
- (b) If Contractor does not promptly comply with the terms of PWC's written instructions, or in an emergency where delay would cause serious risk of loss or damage, PWC may have the defective Work corrected or repaired or may have the rejected Work removed and replaced. Contractor shall pay all claims, costs, losses, and damages (including but not limited to all fees and charges of engineers, architects, attorneys, and other professionals and all court or arbitration or other dispute resolution costs) arising out of or relating to such correction or repair or such removal and replacement (including but not limited to all costs of repair or replacement of work of others).
- (c) In special circumstances where a particular item of equipment is placed in continuous service before Substantial Completion of all the Work, the correction period for that item may start to run from an earlier date only as provided in the Contract Documents.
- (d) Where defective Work (and damage to other Work resulting therefrom) has been corrected or removed and replaced under this Article XII, the correction period hereunder with

respect to such Work will be extended for an additional period of one year after such correction or removal and replacement has been satisfactorily completed.

- (e) Contractor's obligations under this Article XII are in addition to all other obligations and warranties. The provisions of this Article XII shall not be construed as a substitute for, or a waiver of, the provisions of any applicable statute of limitation or repose.

Article XIII. Suspension of Work and Termination

Section 13.01 PWC May Suspend Work

- (a) At any time and without cause, PWC may suspend the Work or any portion thereof for a period of not more than 90 consecutive calendar days by written notice to Contractor and Design Engineer. Such notice will fix the date on which Work will be resumed. Contractor shall resume the Work on the date so fixed. Contractor shall be entitled to an adjustment in the Contract Price or an extension of the Contract Times, or both, directly attributable to any such suspension. Any Change Proposal seeking such adjustments shall be submitted no later than thirty (30) calendar days after the date fixed for resumption of Work.

Section 13.02 PWC May Terminate for Cause

- (a) The occurrence of any one or more of the following events will constitute a default by Contractor and justify termination for cause:
 - (i) Contractor's continued failure to perform the Work in accordance with the Contract Documents (including, but not limited to, failure to supply sufficient skilled workers or suitable materials or equipment or failure to adhere to the Progress Schedule);
 - (ii) Failure of Contractor to perform or otherwise to comply with a material term of the Contract Documents;
 - (iii) Contractor's disregard of Laws or Regulations of any public body having jurisdiction; or
 - (iv) Contractor's repeated disregard of the authority of PWC, Project Engineer, or Design Engineer.
- (b) If one or more of the events identified in Paragraph 13.02(a) occurs, then after giving Contractor (and any surety) ten (10) calendar days written notice that PWC is considering a declaration that Contractor is in default and termination of the Agreement, PWC may proceed to:
 - (i) declare Contractor to be in default, and give Contractor (and any surety) notice that the Contract is terminated; and
 - (ii) enforce the rights available to PWC under any applicable performance bond.
- (c) Subject to the terms and operation of any applicable performance bond, if PWC has terminated the Contract for cause, PWC may exclude Contractor from the Site, take possession of the Work, incorporate in the Work all materials and equipment stored at the Site or for which PWC has paid Contractor but which are stored elsewhere, and complete the Work as PWC may deem expedient.
- (d) PWC may not proceed with termination of the Contract under Paragraph 13.02(b) if Contractor within seven (7) calendar days of receipt of notice of intent to terminate begins to correct its failure to perform and proceeds diligently to cure such failure and such efforts

are agreed to by PWC.

- (e) If PWC proceeds as provided in Paragraph 13.02(b), Contractor shall not be entitled to receive any further payment until the Work is completed. If the unpaid balance of the Contract Price exceeds the cost to complete the Work, including all related claims, costs, losses, and damages (including but not limited to all fees and charges of engineers, architects, attorneys, and other professionals) sustained by PWC, such excess will be paid to Contractor. If the cost to complete the Work including such related claims, costs, losses, and damages exceeds such unpaid balance, Contractor shall pay the difference to PWC. Such claims, costs, losses, and damages incurred by PWC will be reviewed by PWC as to their reasonableness and, when so approved by PWC, incorporated in a Change Order.
- (f) Where Contractor's services have been so terminated by PWC, the termination will not affect any rights or remedies of PWC against Contractor then existing or which may thereafter accrue, or any rights or remedies of PWC against Contractor or any surety under any payment bond or performance bond. Any retention or payment of money due Contractor by PWC will not release Contractor from liability.
- (g) The provisions of any applicable payment or performance bond shall govern over any inconsistent provisions of this Section.

Section 13.03 PWC May Terminate For Convenience

- (a) Upon seven (7) calendar days written notice to Contractor, PWC may, without cause and without prejudice to any other right or remedy of PWC, terminate the Contract. In such case, Contractor shall be paid for (without duplication of any items):
 - (i) completed and acceptable Work executed in accordance with the Contract Documents prior to the effective date of termination, including fair and reasonable sums for overhead and profit on such Work;
 - (ii) expenses sustained prior to the effective date of termination in performing services and furnishing labor, materials, or equipment as required by the Contract Documents in connection with uncompleted Work, plus fair and reasonable sums for overhead and profit on such expenses; and
 - (iii) other reasonable expenses directly attributable to termination, including costs incurred to prepare a termination for convenience cost proposal.
- (b) Contractor shall not be paid on account of loss of anticipated overhead, profits, or revenue, or other economic loss arising out of or resulting from such termination.

Section 13.04 Contractor May Stop Work or Terminate

- (a) If, through no act or fault of Contractor, (1) the Work is suspended for more than ninety (90) consecutive calendar days by PWC or under an order of court or other public authority or (2) PWC fails for sixty (60) calendar days to pay Contractor any sum finally determined to be due, then Contractor may, upon seven (7) calendar days written notice to PWC, and provided PWC does not remedy such suspension or failure within that time, terminate the Contract and recover from PWC payment on the same terms as provided in this Article.
- (b) In lieu of terminating the Contract and without prejudice to any other right or remedy, if PWC has failed for thirty (30) calendar days to pay Contractor any sum finally determined to be due, Contractor may, seven (7) calendar days after written notice to PWC, stop the Work until payment is made of all such amounts due Contractor, including interest thereon.

General Conditions (Rev 7/11/2023)

The provisions of this paragraph are not intended to preclude Contractor from submitting a Change Proposal for an adjustment in Contract Price or Contract Times or otherwise for expenses or damage directly attributable to Contractor's stopping the Work as permitted by this paragraph.

Section 13.05 Morality

- (a) If, in the sole opinion of PWC, at any time Contractor or any of its owner(s) or employee(s) or agent(s) (each party, owner, employee, and agent is an "Actor") engages in any one or more actions that bring disrepute, contempt, scandal, or public ridicule to the Actor or subject the Actor to prosecution or offend the community or public morals or decency or denigrate individuals or groups in the community served by PWC or are scandalous or inconsistent with community standards or good citizenship or may adversely affect PWC's finances, public standing, image, or reputation or are embarrassing or offensive to PWC or may reflect unfavorably on PWC or are derogatory or offensive to one or more employee(s) or customer(s) of PWC, PWC may immediately upon written notice to Contractor terminate the Agreement, in addition to any other rights and remedies that PWC may have pursuant to the Contract Documents or at law or in equity.

Article XIV. Miscellaneous

Section 14.01 Additional General Terms and Conditions

- (a) Contractor shall be subject to any additional terms and conditions for this Project as set forth in the applicable Appendices as specific in the Agreement, which is incorporated by reference as if set forth word-for-word herein.

Section 14.02 Giving Notice

- (a) Whenever any provision of the Contract Documents requires the giving of written notice, it will be deemed to have been validly given if:
- (i) delivered in person, by a commercial courier service or otherwise, to the individual or to a member of the firm or to an officer of the corporation for which it is intended;
 - (ii) delivered at or sent by registered or certified mail, postage prepaid, to the last business address known to the sender of the notice; or
 - (iii) sent to PWC or Contractor's designee(s) via email, with a confirmation of receipt.

Section 14.03 Computation of Times

- (a) When any period of time is referred to in the Contract by days, it will be computed to exclude the first and include the last day of such period. If the last day of any such period falls on a Saturday or Sunday or on a day made a legal holiday by the law of the applicable jurisdiction, such day will be omitted from the computation.

Section 14.04 Cumulative Remedies

- (a) The duties and obligations imposed by these General Conditions and the rights and remedies available hereunder to the parties are in addition to, and are not to be construed in any way as a limitation of, any rights and remedies available to any or all of them which

General Conditions (Rev 7/11/2023)

are otherwise imposed or available by Laws or Regulations, by special warranty or guarantee, or by other provisions of the Contract Documents. The provisions of this paragraph will be as effective as if repeated specifically in the Contract Documents in connection with each particular duty, obligation, right, and remedy to which they apply.

Section 14.05 Limitation of Damages

- (a) With respect to any and all Change Proposals, Claims, disputes subject to final resolution, and other matters at issue, neither PWC nor Design Engineer, nor any of their officers, directors, members, partners, employees, agents, consultants, or subcontractors, shall be liable to Contractor for any claims, costs, losses, or damages sustained by Contractor on or in connection with any other project or anticipated project.

Section 14.06 No Waiver

- (a) A party's non-enforcement of any provision shall not constitute a waiver of that provision, nor shall it affect the enforceability of that provision or any other provision of the Contract Documents.

Section 14.07 Survival of Obligations

- (a) All representations, indemnifications, warranties, and guarantees made in, required by, or given in accordance with the Contract Documents, as well as all continuing obligations indicated in the Contract Documents, will survive final payment, completion, and acceptance of the Work or termination or completion of the Agreement or termination of the services of Contractor.

Section 14.08 Controlling Law

- (a) The Agreement shall be governed by the law of the State of North Carolina.

Section 14.09 Headings

- (a) Article and paragraph headings, numbers, and letters are inserted for convenience only and do not constitute parts of these General Conditions.

DIVISION 1

PERFORMANCE BOND

Date of Execution: _____

Name of Principal: _____

(Contractor)

Name of Surety: _____

Name of Contracting

Body: Fayetteville Public Works Commission, Fayetteville, N.C.

Amount of Bond: _____

PROJECT: PWC2526102 - LIFT STATION 33 CARGILL LIFT STATION STRUCTURAL REPAIR

KNOW ALL MEN BY THESE PRESENTS, That We, the Principal and Surety above named, are held and firmly bound unto the above named Contracting Body, hereinafter called the Contracting Body, in the penal sum of the amount stated above the payment of which sum well and truly to be made, we bind ourselves, our heirs, executors, administrators, and successors, jointly and severally, firmly by these present.

THE CONDITION OF THIS OBLIGATION IS SUCH that whereas the Principal entered into a certain Contract with the Contracting Body, identified as shown above and hereto attached.

NOW, THEREFORE, if the Principal shall well and truly perform and fulfill all the undertakings, covenants, terms, conditions, and agreements of said Contract during the original term of said Contract and any extensions there of that may be granted by the Contracting Body, with or without notice to the Surety, and during the life of any Guaranty required under the Contract, and shall also well and truly perform and fulfill all the undertakings, covenants, terms, conditions, and agreements of any and all duly authorized modifications of said Contract that may hereafter be made, notice of which modifications to the Surety being hereby waived, then, this obligation to be void; otherwise to remain in full force and virtue.

IN WITNESS WHEREOF, the above bounded parties have executed this instrument under the several seals on the date indicated above, the name and corporate seal of each corporate party being hereto affixed, and these presents duly signed by its undersigned representative, pursuant to authority of its governing body.

Executed in _____ counterparts.

Witness:

(Proprietorship of Partnership)

By:

Title:

(Corporate Secretary or
Assistant Secretary, Only)

CONTRACTOR:

(Trade or Corporate Name)

By:

Title:

(Owner, Partner, Corporate President or
Vice-President, Only)
(CORPORATE SEAL)

Witness:

Countersigned:

(N.C. Licensed Resident Agent)

SURETY COMPANY:

(Surety Company Name)

By:

Title:

(Attorney in Fact)
(SURETY CORPORATE SEAL)

PAYMENT BOND

Date of Execution: _____

Name of Principal: _____
(Contractor)

Name of Surety: _____

Name of Contracting

Body: Fayetteville Public Works Commission, Fayetteville, N.C.

Amount of Bond: _____

PROJECT: PWC2526102 - LIFT STATION 33 CARGILL LIFT STATION STRUCTURAL REPAIR

KNOW ALL MEN BY THESE PRESENTS, that We, the PRINCIPAL and Surety above named, are held and firmly bound unto the above named Contracting Body, hereinafter called the Contracting Body, in the penal sum of the amount stated above the payment of which sum well and truly to be made, we bind ourselves, our heirs, executors, administrators, and successors, jointly and severally, firmly by these presents.

THE CONDITION OF THIS OBLIGATION IS SUCH that whereas the Principal entered into a certain Contract with the Contracting Body, identified as shown above and hereto attached.

NOW THEREFORE, if the Principal shall promptly make payment to all persons supplying labor and material in the prosecution of the work provided for in said contract, and any and all duly authorized modifications of said contract that may hereafter be made, notice of which modifications to the Surety being hereby waived, then, this obligation to be void; otherwise to remain in full force and virtue.

IN WITNESS WHEREOF, the above bounded parties have executed this instrument under the several seals on the date indicated above, the name and corporate seal of each corporate party being hereto affixed, and these presents duly signed by its undersigned representative, pursuant to authority of its governing body.

Executed in _____ counterparts.

Witness:

CONTRACTOR:

(Proprietorship of Partnership)

(Trade or Corporate Name)

By:

By:

Title:

Title:

(Corporate Secretary or
Assistant Secretary, Only)

(Owner, Partner, Corporate President or
Vice-President, Only)
(CORPORATE SEAL)

Witness:

SURETY COMPANY:

(Surety Company Name)

By:

Countersigned:

Title:

(N.C. Licensed Resident Agent)

(Attorney in Fact)
(SURETY CORPORATE SEAL)

**POWER OF ATTORNEY
(ATTACH)**

**CERTIFICATE(S) OF INSURANCE
(Attach)**

NOTICE TO PROCEED

TO: _____

Date: _____

PROJECT: PWC2526102 - LIFT STATION 33 CARGILL LIFT STATION STRUCTRAL REPAIR

You are hereby notified to commence work in accordance with the Contract dated _____, 2026, on or before _____, 2026, and you are to complete the WORK within the **contract period** thereafter. The date of final completion therefore is _____.

FAYETTEVILLE PUBLIC WORKS COMMISSION

BY: _____

Nikole Bohannon

Procurement Manager

ACCEPTANCE OF NOTICE

Receipt of the above NOTICE TO PROCEED

is hereby acknowledged this the _____ day of _____, 2026.

(CONTRACTOR)

BY: _____

TITLE: _____

- END OF SECTION -

SECTION C - ADMINISTRATIVE PROVISIONS

***** THIS PAGE WAS INTENTIONALLY LEFT BLANK *****

DIVISION I
01025 – MEASUREMENT AND PAYMENT

GENERAL

The purpose of this Section is to define the methods of measurement and payment for each of the unit prices and/or lump sum prices listed in the Bid Form, which are required to construct the Work.

The unit price and/or lump sum price bid shall be full compensation for the work required under each bid item, which shall include all incidental costs relative thereto. Certain items of work are specified and/or shown as a detail in the Contract Documents; bid prices shall include all items of work required to furnish and/or install each in accordance with the Project requirements, whether specifically stated or itemized in the Measure and Payment description.

No payment will be made for stored materials.

1.01 Cargill Lift Station Structural Repairs

The lump sum unit price bid for the Cargill Lift Station Structural Repairs shall include all work necessary to complete the work in accordance with these Contract Documents. Payment under this item shall include all costs of mobilization, bonds, insurance, and other related costs. The lump sum price shall also include, but is not limited to erosion control, access to lift station, placement of reinforcing steel, welding, demolition of existing handrails, demolition of grating, demolition of grating supports, demolition of pipe supports, design replacement for deteriorated structural steel and aluminum elements at the existing wet well, leave existing pump equipment, piping metering devices, in place but temporarily detach as required to complete the removal and replacement, and properly dispose of all materials, site restoration, structural steel and materials, bolts, nuts, and fasteners, epoxy anchoring system, bar grating, guying and bracing, framing, bridging to avoid conflicts with existing ducts, plumbing, or other utilities to complete the work, and all necessary equipment, material, labor and incidentals to complete the work.

*** END OF SECTION ***

DIVISION I
1300 – SUBMITTALS

1.01 THE REQUIREMENT

- A. This section specifies the means of all submittals. All submittals shall be submitted to the Fayetteville Public Works Commission. A general summary of the types of submittals and the number of copies required is as follows:

<u>Electronic Submittal</u>	<u>Type of Submittal</u>
1	Administrative Submittals
1	Construction schedule
1	Shop drawings
1	Preconstruction Video
1	Certificates of compliance
1	Warranties

- B. All submittals shall be provided in accordance with this Section, and as outlined in Section 01000 – Special Conditions. The Contractor shall refer to other Specification Sections within these Contract Documents, to ensure that all submittal requirements are adhered to. No construction shall proceed until all required submittals have been reviewed and approved by the Fayetteville Public Works Commission. Any and all work performed prior to review and acceptance of the submittals by the Fayetteville Public Works Commission shall be at the Contractor’s sole risk. Further, failure to comply with the requirements of this Section may be considered Breach of Contract, and grounds for termination.

1.02 SUBMITTAL PROCEDURES

- A. The Contractor shall transmit each submittal with a form acceptable to the Fayetteville Public Works Commission, clearly identifying the project and the Contractor, the enclosed material and other pertinent information specified in other parts of this section. The submittal shall identify variations from the Contract Documents and Product or system limitations which may be detrimental to successful performance of the completed Work.
- B. The Contractor shall revise and resubmit submittals as required, identifying all changes made since previous submittals. Resubmittals shall be noted as such.
- C. The Contractor shall distribute copies of reviewed submittals to concerned parties, with instructions to those parties to promptly report any inability to comply with provisions.

1.03 ADMINISTRATIVE SUBMITTALS

- A. All administrative submittals shall be prepared and submitted in accordance with the Submittal Checklist provided in these Contract Documents. All Preconstruction Administrative submittals must be submitted and approved prior to the release of Contractor’s first Application for Payment. Construction Administrative Submittals must be submitted and approved prior to the release of monthly pay applications. Post

Construction Administrative Submittals must be submitted and approved prior to the release of the Contractor's Final Application for Payment.

1.04 CONSTRUCTION SCHEDULE

- A. The construction schedule shall be prepared and submitted in accordance with Specification Section 01310. A PDF copy of the schedule shall be submitted to the Project Engineer within 10 calendar days after the date of the Notice to Proceed.
- B. The construction schedule shall be revised to reflect comments by the Fayetteville Public Works Commission and updated monthly, depicting progress to the last day of the month. A PDF copy shall be submitted to the Project Engineer no later than the Monday prior to each Monthly Progress Meeting.
- C. Changes to the schedule shall be accompanied by a letter of explanation with appropriate reference and revision date on the schedule.

1.05 SHOP DRAWINGS

- A. General: The Contractor shall submit for review shop drawings for concrete reinforcement, structural details, materials fabricated especially for this Contract, and materials for which such Drawings are specified (as outlined in these Contract Documents) or as specifically requested by the Fayetteville Public Works Commission.
- B. Shop drawings shall show the principal dimensions, weight, structural and operating features, type and/or brand of finish or shop coat, grease fittings, etc., depending on the subject of the Drawings.
- C. When so specified, or if considered by the Fayetteville Public Works Commission to be acceptable, the manufacturer's specifications, catalog data, descriptive matter, illustrations, etc. may be submitted for review in place of shop drawings. In such case, the requirements shall be as specified for shop drawings, insofar as applicable.
- D. The Contractor shall be responsible for the prompt submittal of all shop drawings so that there shall be no delay to the Work due to the absence of such Drawings. The Fayetteville Public Works Commission will review the shop drawings within 10 business days of receipt of such Drawings. Reviewed shop drawings will be returned to the Contractor by regular mail.
- E. Time delays caused by rejection of submittals are not cause for extra charges to the Fayetteville Public Works Commission or time extensions.
- F. Requirements: All shop drawings shall be submitted to the Fayetteville Public Works Commission through the Contractor. The Contractor is responsible for obtaining shop drawings from his subcontractors and returning reviewed Drawings to them. All shop drawings shall be prepared on standard size, 24-inch by 36-inch sheets, or smaller, as approved by the Fayetteville Public Works Commission. All Drawings shall be clearly marked with the name of the project, Fayetteville Public Works Commission, Contractor, and pay item to which the drawing applies. Drawings shall be suitably numbered and stamped by the Contractor. Each shipment of Drawings shall be accompanied by a letter of transmittal giving a list of the drawing numbers and the names mentioned above.

1.06 PRODUCT DATA

- A. Where manufacturer's publications in the form of catalogs, brochures, illustrations, or other data sheets are submitted in lieu of prepared shop drawings, such submission shall specifically indicate the particular item offered. Identification of such items and

relative pertinent information shall be made with indelible ink. Submissions showing only general information will not be accepted.

- B. Product data shall include materials of construction, dimensions, performance characteristics and capacities, etc.
- C. Pipe manufacturer shall submit documentation for all pipe being supplied to this project indicating date of manufacture, type and place of storage, shipping methods, dates of delivery to site, and all required testing data. Pipe internal surface shall be smooth and free of all cuts, gouges, or scratches. Surface cuts or scratches greater than or equal to the maximum defect depth are not acceptable.

1.07 SAMPLE WARRANTIES

- A. When warranties are called for, a sample of the warranty shall be submitted with the shop drawings. The sample warranty shall be the same form that will be used for the actual warranty.

1.08 WORK PRIOR TO REVIEW

- A. No material or equipment shall be purchased, fabricated especially for this Contract, or delivered to the project site until the required shop drawings have been submitted, processed and marked either "APPROVED" or "APPROVED AS NOTED". All materials and Work involved in the construction shall be as represented by said Drawings.
- B. The Contractor shall not proceed with any portion of the Work for which the design and details are dependent upon the design and details of equipment for which submittal review has not been completed.

1.09 CONTRACTOR'S REVIEW

- A. Only submittals which have been checked and corrected should be submitted to the Contractor by his subcontractors and vendors. Prior to submitting shop drawings to the Fayetteville Public Works Commission, the Contractor shall check thoroughly all such Drawings to satisfy himself that the subject matter thereof conforms to the Drawings and Specifications in all respects. Drawings which are correct shall be marked with the date, checker's name and indications of the Contractor's approval, and then shall be submitted to the Fayetteville Public Works Commission; other Drawings submitted to the Fayetteville Public Works Commission will be returned to the Contractor unreviewed.
- B. The review of shop drawings will be general and shall not relieve the Contractor of the responsibility for details of design, dimensions, etc., necessary for proper fitting and construction of the Work required by the Contract and for achieving the specified performance.
- C. For submissions containing departures from the Contract Documents, the Contractor shall include proper explanation in his letter of transmittal. Should the Contractor submit for review equipment that requires modifications to the structures, piping, layout, etc. detailed on the Drawings, he shall also submit for review details of the proposed modifications. If such equipment and modifications are accepted, the Contractor, at no additional cost to the Fayetteville Public Works Commission, shall do all Work necessary to make such modifications.

1.10 SUBSTITUTIONS

- A. Whenever a particular brand or make of material, equipment, or other item is specified, or is indicated in these Contract Documents, it is for the purpose of establishing a standard of quality, design, and type desired and to supplement the detailed specifications. Any other brand or make which, in the opinion of the Fayetteville Public Works Commission, is equivalent to that specified or indicated may be offered as a substitute subject to the following provisions:
 - 1. Contractor shall submit for each proposed substitution sufficient details, complete descriptive literature, and performance data together with samples of the materials, where feasible, to enable the Fayetteville Public Works Commission to determine if the proposed substitution is equal.
 - 2. Contractor shall submit certified tests, where applicable, by an independent laboratory attesting that the proposed substitution is equal.
 - 3. A list of installations (including contact information) where the proposed substitution is equal.
 - 4. Where the acceptance of a substitution requires revision or redesign of any part of the Work, all such revision and redesign, and all new Drawings and details required therefore, shall be provided by the Contractor at his own cost and expense, and shall be subject to review of the Fayetteville Public Works Commission.
 - 5. In all cases the Fayetteville Public Works Commission shall be the sole judge as to whether a proposed substitution is to be accepted. The Contractor shall abide by the Fayetteville Public Works Commission 's decision when proposed substitute items are judged to be unacceptable and shall in such instances furnish the item, or substitute, as specified. No substitute items shall be used in the Work without written acceptance of the Fayetteville Public Works Commission. The Fayetteville Public Works Commission reserves the right to reject any such proposed changes or substitutions at their sole discretion, and is under no obligation to justify their decision.
 - 6. Acceptance of any proposed substitution shall in no way release the Contractor from any of the provisions of the Contract Documents.
- B. Each submittal shall be complete in all aspects incorporating all information and data required to evaluate the products' compliance with the Contract Documents. Partial or incomplete submissions shall be returned to the Contractor without review.
 - 1. Shop Drawing Distribution: The Contractor shall submit one (1) PDF copy of all shop drawings to the Fayetteville Public Works Commission for review. Shop drawings will be reviewed, stamped and returned with the appropriate box checked either "APPROVED", "APPROVED AS NOTED", "NOT APPROVED" or "REVISE AND RESUBMIT".
 - 2. If the Contractor requires additional copies of returned shop drawings, he shall include extra Drawings in his original submittal. The Fayetteville Public Works Commission will process the Drawings and return them to the Contractor.

1.11 PRODUCT SAMPLES

- A. Contractor shall furnish for review all product samples as required by the Contract Documents or requested by the Fayetteville Public Works Commission to determine compliance with the specifications.

- B. Samples shall be of sufficient size or quantity to clearly illustrate the quality, type, range of color, finish or texture and shall be properly labeled to show complete project identification, the nature of the material, trade name of manufacturer and location of the Work where the material represented by the sample will be used.
- C. Samples shall be checked by the Contractor for conformance to the Contract Documents before being submitted to the Fayetteville Public Works Commission and shall bear the Contractor's stamp certifying that they have been so checked. Transportation charges on samples submitted to the Fayetteville Public Works Commission shall be prepaid by the Contractor.
- D. Fayetteville Public Works Commission's review will be for compliance with the Contract Documents, and his comments will be transmitted to the Contractor within 15 business days of receipt.
- E. Acceptable samples will establish the standards by which the completed Work will be judged.

1.12 PRECONSTRUCTION VIDEO

- A. The Contractor shall document pre-existing conditions on the project site in accordance with these Contract Documents. This shall be done prior to Work beginning in the area. The video shall be submitted to the Project Engineer before the first payment application can be released.

1.13 RECORD DRAWINGS

- A. Upon completion of the Work, the Contractor shall provide two complete sets of drawings recording all changes to the work to indicate actual installation. Changes shall be noted in legible red letters. These changes shall include but are not limited to the following:
 - 1. Change in pipe material
 - 2. Change in manhole location
 - 3. Size, depth, and installed elevations of mains, laterals, force mains, manholes and lift stations.
 - 4. Location of valves, blow-offs, and other appurtenances
 - 5. Changes in location or extent of grout filled mains.
 - 6. Changes in force main bend locations, restrained joints or casings.
- B. Completion of the Contractor's record drawings is a specific contract requirement, and final payment will not be made until these drawings and project manual (as required) have been submitted to and approved by the Project Engineer.

1.14 CERTIFICATES OF COMPLIANCE

- A. Copies of certificates of compliance and test reports shall be submitted for requested items to the Fayetteville Public Works Commission prior to request for payment.

1.15 WARRANTIES

- A. Original warranties, called for in the Contract Documents, shall be submitted to the Fayetteville Public Works Commission. When warranties are required for an item, the warranty shall be submitted prior to request for payment of that item.
- B. When warranties are requested, a sample of the warranty to be provided shall be submitted with, and considered part of, the shop drawings.

- C. The Contractor shall warrant to the Fayetteville Public Works Commission that all material and labor used in the construction are covered by his warrantee for a minimum of a one (1) year period upon approval and acceptance by the Fayetteville Public Works Commission. The Contractor shall replace or repair defects at no cost to the Fayetteville Public Works Commission during the warrantee period.

*** END OF SECTION ***

DIVISION I
1310 – CONSTRUCTION SCHEDULE

Part 1 – GENERAL

1.01 Work Included:

- A. This section specifies requirements and procedures in preparing and updating construction schedules and reports for planning, coordinating, executing and monitoring the progress of the work. The construction work shall be scheduled to be completed within the specified duration of the Contract.

1.02 Related Work Specified Elsewhere

- A. Special Provisions
- B. General Conditions
- C. Submittals

1.03 Scheduling Responsibilities

- A. The construction schedule will be used to monitor job progress. The Contractor will be responsible for providing all information concerning the sequencing, logic and durations of planned activities. The Contractor will be responsible for providing monthly update information on logic changes, percent complete, actual start and finish dates and duration changes. The Contractor will be required to produce the monthly, computerized printout of the schedule updates.
- B. Assembling the initial schedule in hand drawn or computer-generated (preferred) form is the responsibility of the Contractor.
- C. It should be clearly understood that the initial schedule and all update information must be provided by the Contractor and that this information is a representation of the best efforts of the Contractor and his subcontractors as to how they envision the work to be accomplished. Similarly, all progress information to be provided by and through the Contractor must be an accurate representation of his or his subcontractors' or suppliers' actual performance. The schedule shall at all times remain an accurate reflection of the Contractor's actual or projected sequencing of the work. Once accepted, adherence to the schedule shall be obligatory upon the Contractor and his subcontractor for the work under this Contract. Owner may require the Contractor to revise the schedule if, in the Project Engineer's judgment, the schedule does not accurately reflect the actual extension of the work, or is in violation of any provision of the Contract Documents. The Contractor shall provide the necessary information required to revise the schedule as often as is necessary during the course of performance of the work without additional cost to the Owner.

1.04 Progress of Work

- A. The work shall be started on the date indicated in the Notice to Proceed and shall be executed with such progress as may be required to prevent delay to other Contractors or to the general completion of this project. The Contractor shall at all times, schedule and direct his work so that it provides an orderly progression of the work to completion within the specified Contract Time. The Contractor shall account

for traffic control requirements, access of citizens within the work area and the requirements for timely restoration.

- B. The Contractor agrees that, whenever it becomes apparent from the current monthly schedule update that delays to the planned progress of work have resulted and these delays are through no fault of the Owner and hence, the Contract completion date will not be met, or when so directed by the Project Engineer, he will prepare a recovery schedule outlining steps to recover time and to complete the project on schedule.
- C. The Contractor shall submit for review a written statement of the steps he intends to take, to remove or arrest the delay to the schedule. The Contractor shall promptly provide such level of effort at no additional cost to the Owner. In addition, should schedule delays persist; the Contractor's surety will be asked to attend a schedule update meeting.
- D. Failure of the Contractor to comply with the requirements of this provision shall subject him to, at the Owner's sole discretion, withholding, in partial or in total, payments otherwise due the Contractor for work due under this Contract. The Contractor agrees that any withholding of monies is not a penalty for noncompliance, but is an assurance for the Owner that funds will be available to implement these requirements should the Contractor fail to do so, since failure of the Contractor to comply with these requirements shall mean that the Contractor failed to execute the work with such diligence as to ensure its completion within the time for completion.

Part 2 – CONSTRUCTION SCHEDULE

2.01 Schedule Requirements

- A. The schedule shall show the order and interdependence of activities and the sequence in which the work is to be accomplished as planned by the Contractor. The schedule shall show how the start date of a given activity is dependent on the completion date of preceding activities how its completion restricts the start of succeeding activities. A time scaled precedence format will be followed. The schedule shall indicate the start date, completion date, and duration (in days), of each activity.
- B. The Schedule Activities shall be developed into two major groups:
 - 1. Construction Activities - Construction activities will be physical work activities that describe how the job will be constructed. Work shall include planned restoration and paving.
 - 2. Post Construction Testing, Start-up, Training and Close-out - Activities for this group shall include all work required satisfying appropriate specification requirements sections and meeting the requirements of final completion. There are at least 3 mandatory activities: Punch list, Final Walkthrough and Project Complete.
- C. The Contractor shall break the work into activity durations of one to twenty (1 to 20) working days each, except for non-construction activities (such as procurement of materials and delivery of equipment) and other activities that may require longer durations. To the extent feasible, activities related to a specific physical or geographic area of the project should be grouped on the schedule for ease of

understanding and simplification. The selection and number of activities shall be subject to the review of the Project Engineer.

- D. Each activity on the schedule shall have indicated for it the following:
 - 1. Construction activities will be divided by easily recognizable division points such as stationing or street names, area of work, etc.
 - 2. A brief description of the activity will be included. If this description is not definitive, a separate listing of each activity and a descriptive narrative may be required.
 - 3. Where the Contractor intends to perform work concurrently, a resource or crew identifier will be assigned to the activity to indicate parallel paths.
 - 4. Established PWC holidays and other non-work days will be excluded from the schedule.
- E. Failure to include on the schedule any element of work required for the performance of this Contract shall not excuse the Contractor from completing all work required within the applicable Contract Time.
- F. A schedule which shows a completion of any portion of the construction work prior to the Contract Time dates may be accepted but in no event shall be acceptable as a basis for a claim for any delay against the Owner by the Contractor.

Part 3 – SCHEDULE OF SUBMITTALS

3.01 Schedule Implementation

- A. Within (10) calendar days after the Notice to Proceed, the Contractor shall submit a PDF copy of their proposed construction schedule for the entire Contract duration to the Project Engineer.
- B. The Contractor shall submit hard copies and a schedule on disk in a format wholly compatible with Microsoft Project. Submission of an electronic schedule does not preclude any other of the aforementioned individual activity requirements.
- C. If a review of the submitted schedule indicates a work plan that will not complete the work within the Contract time, it shall be the responsibility of the Contractor to revise the schedule as required and resubmit it until it is acceptable. Failure by the Contractor to submit an acceptable schedule may, at the Owner's sole discretion, be cause for the withholding of any partial payment(s) otherwise due under the Contract.
- D. Acceptance of the schedule shall not constitute a representation by the Owner that the work can be completed as shown on the schedule.

3.02 Schedule Updates

- A. The Contractor shall submit a Schedule Update on the Monday prior to the monthly progress meeting, (or as directed by the Project Engineer), to allow the Project Engineer to review the schedule. The schedule shall be up-to-date as of the previous Friday or as directed by the Project Engineer. Actual progress of the previous month shall be recorded and future activities will be reviewed. The duration of activities and their logical connections may be revised as needed. Decisions made at these meetings and agreed to by all parties are binding with the exception that no

contractual completion dates will be modified without formal written requests and acceptance as specified in the Contract Documents. The Contractor must provide the following information for each update at a minimum:

1. Actual start and finish dates for all completed activities.
 2. Actual start dates for all started but incomplete activities including remaining durations and/or percent completes.
 3. Revisions in the logic, critical path or resource assigned to an activity that would affect the anticipated early start of all activities not yet started.
 4. Any approved extension of Contract time shall be included in the next monthly updating of the schedule.
- B. Provide a Monthly Progress Status Report that provides the following items:
1. Summarized revisions made to the Construction Schedule since the previous submittal.
 2. Work anticipated to be started during the next period, including those activities already in progress.
 3. Problem areas, anticipated delays, and the impact on the schedule.
 4. Corrective action.
 5. The effect of changes on schedules of other prime Contractors in adjacent work areas.
- C. Failure to provide update information listed above, or failure to attend progress meetings may result in the Owner withholding partial payments.

- END OF SECTION -

DIVISION I
01400 – QUALITY CONTROL

1.01 QUALITY ASSURANCE

- A. Quality: All materials shall be new and correctly designed, and shall conform to the requirements outlined in these Contract Documents. They shall be standard first-grade quality produced by expert workmen and be intended for the use for which they are offered. Materials which, in the opinion of the Fayetteville Public Works Commission, are inferior or of a lower grade than indicated, specified, or required will not be acceptable.
- B. Source Limitations: To the greatest extent possible for each unit of Work, the Contractor shall provide products, materials, or equipment from a single manufacturer.
- C. Compatibility of Options: If the Contractor cannot obtain all necessary products, materials, and/or equipment from a single manufacturer, the Contractor shall submit compatible products, materials, and/or equipment to the Fayetteville Public Works Commission for review and approval. Once the Fayetteville Public Works Commission has issued approval of the proposed products, materials, and/or equipment, the Contractor shall only utilize that manufacturer's products, materials, and/or equipment, unless otherwise approved in writing by the Fayetteville Public Works Commission.

1.02 QUALITY CONTROL

- A. Quality control is the sole responsibility of the Contractor and shall include the activities of his Subcontractors and all suppliers as required.

1.03 TESTING SERVICES

- A. The Contractor shall cooperate with the Fayetteville Public Works Commission's Consultant performing required testing and provide equipment, access, or other means required at no additional expense to the Fayetteville Public Works Commission. The Contractor shall be responsible for coordinating testing with the PWC Project Coordinator. The Contractor shall be responsible for all costs incurred by the Fayetteville Public Works Commission's Consultant when scheduled testing cannot be performed.
- B. The Fayetteville Public Works Commission shall employ and pay for the services of an independent laboratory for specified testing as outlined in these Contract Documents, with the following exceptions:
 - 1. If Laws and Regulations of any public body having jurisdiction specifically require any part of the Work to be tested, inspected, or approved by an employee or other representative of that public body, the Contractor shall be responsible for arranging and obtaining such inspections and/or approvals. The Contractor shall bear all costs associated with the required testing, inspections, and/or approvals, and shall furnish the Fayetteville Public Works Commission all required documentation that the required testing, inspection, and/or approvals have been obtained.
 - 2. If any part of the Work is found to be defective and not in compliance with the Contract Documents, the Contractor shall be responsible for all subsequent testing necessary to prove that the Work has been brought into compliance. Any

necessary testing to ensure compliance shall be directed by the PWC Project Coordinator and/or PWC Project Engineer.

3. When scheduled testing by the Fayetteville Public Works Commission's Consultant cannot be performed.
4. Arranging and obtaining any required inspections, testing, or approvals required in connection with the Fayetteville Public Works Commission's acceptance of a material supplier, or equipment proposed to be incorporated into the Work, or materials, mix designs, etc. submitted for approval prior to purchase for incorporation into the Work. All inspections, tests, and approvals shall be performed by organizations acceptable to the Fayetteville Public Works Commission.

1.04 PRODUCT EVALUATION

- A. Testing shall be accomplished as deemed necessary by the Fayetteville Public Works Commission to ensure that the products conform to the requirements of the Contract Documents.
- B. The work or actions of the testing laboratory shall in no way relieve the Contractor of his obligations under the Contract. The laboratory testing work will include such inspections and testing required by the Contract Documents, existing laws, codes, ordinances, etc. The testing laboratory will have no authority to change the requirements of the Contract Documents, nor perform, accept or approve any of the Contractor's Work.
- C. The Contractor shall allow the Fayetteville Public Works Commission ample time and opportunity for evaluation and testing materials to be used in the Work. The Contractor shall advise the Fayetteville Public Works Commission promptly upon placing orders for materials so that arrangements may be made, if desired, for evaluation before shipment from the place of manufacture. The Contractor shall at all times furnish the Fayetteville Public Works Commission and his representatives, facilities including labor, and allow proper time for evaluation and testing materials, and workmanship. The Contractor must anticipate that possible delays may occur due to the necessity of materials being inspected and accepted for use. The Contractor shall furnish, at his own expense, all samples of materials required by the Fayetteville Public Works Commission for testing, and shall make his own arrangements for providing water, electric power, or fuel for the various evaluation and tests of structures and materials.
- D. The Fayetteville Public Works Commission will bear the cost of all tests, evaluation, or investigations undertaken by the order of the PWC Project Engineer for the purpose of determining conformance with the Contract Documents if such tests, evaluation, or investigations are not specifically required by the Contract Documents, and if conformance is ascertained thereby. Whenever nonconformance is determined by the Fayetteville Public Works Commission as a result of such tests, evaluation, or investigations, the Contractor shall bear the full cost of any additional tests, evaluations and investigations, which are ordered by the Fayetteville Public Works Commission to ascertain subsequent conformance with the Contract Documents.

1.05 EVALUATION AT PLACE OF MANUFACTURE

- A. Unless otherwise specified, all products and materials shall be subject to evaluation by the Fayetteville Public Works Commission at the place of manufacture.
- B. The presence of the Fayetteville Public Works Commission at the place of manufacture, however, shall not relieve the Contractor of the responsibility for furnishing products, materials, and equipment which comply with all requirements of the Contract Documents. Compliance is a duty of the Contractor, and said duty shall not be avoided by any act or omission on the part of the Fayetteville Public Works Commission.

1.06 SAMPLING AND TESTING

- A. Unless otherwise specified, all sampling and testing shall be in accordance with the methods prescribed in the current standards of the ASTM, as applicable to the class and nature of the article or materials considered. However, the Fayetteville Public Works Commission reserves the right to use any generally accepted system of sampling and testing which will ensure that the quality of the workmanship is in full accord with the Contract Documents.
- B. Any waiver by the Fayetteville Public Works Commission of any specific testing or other quality assurance measures shall not be construed as a waiver of any requirements of the Contract Documents. The Fayetteville Public Works Commission may require a guarantee of substantial performance and/or a performance bond to ensure any necessary corrective or remedial Work, should a waiver be granted.
- C. The Fayetteville Public Works Commission reserves the right to make independent investigations and tests. Failure of any portion of the Work to meet any of the requirements of the Contract Documents shall be reasonable cause for the Fayetteville Public Works Commission to require the removal or correction and reconstruction of any such work in accordance with the Contract Documents. In addition to any other evaluation, observation or quality assurance provisions that may be specified, the Fayetteville Public Works Commission shall have the right to independently select, test, and analyze, at their expense, additional test specimens or any or all of the materials to be used. Results of such tests and analyses shall be considered along with the tests or analyses made by the Contractor to determine compliance with the applicable specifications for the materials so tested or analyzed. The Contractor shall be responsible for all costs of removal, correction, and reconstruction or repair of any such Work that fails to meet the requirements of the Contract Documents.

1.07 SITE INVESTIGATION AND CONTROL

- A. The Contractor shall verify all dimensions in the field and shall check field conditions continuously during construction. The Contractor shall be solely responsible for any inaccuracies built into the Work due to their failure to comply with this requirement.
- B. The Contractor shall inspect related and appurtenant Work and shall report in writing to the Fayetteville Public Works Commission any conditions which will prevent proper completion of the Work. Failure to report any such conditions shall constitute acceptance of all site conditions, and any required removal, repair, or replacement caused by unsuitable conditions shall be performed by the Contractor at their sole cost and expense.

1.08 RIGHT OF REJECTION

- A. The Fayetteville Public Works Commission shall have the right, at all times, to reject any articles or materials to be furnished hereunder which, in any respect, fail to meet the requirements of the Contract Documents, regardless of whether the defects in such articles or materials are detected at the point of manufacture or after completion of the Work. If the Fayetteville Public Works Commission, through an oversight or otherwise, has accepted materials or Work which is defective or which is contrary to the Contract Documents, such materials, no matter in what stage or condition of manufacture, delivery, or erection, may be subsequently rejected by the Fayetteville Public Works Commission.
- B. The Contractor shall promptly remove rejected articles or materials from the Work after notification of rejection. All costs of removal and replacement of rejected articles or materials as specified herein shall be borne by the Contractor.

1.09 WATERTIGHTNESS OF STRUCTURES

- A. It is the intent of these Contract Documents that all Work shall be performed as required by quality construction to ensure proper sealing so that groundwater and/or rainwater will not leak into any collection line, service lateral, or manhole.
- B. The Contractor shall provide at its own expense all labor, material, temporary bulkheads, pumps, water, measuring devices, etc., necessary to perform the required tests.

1.10 HYDRAULIC UPLIFT ON STRUCTURES

- A. The Contractor shall be completely responsible for any pipelines or manholes that may become buoyant before the Work is completed and accepted. The Contractor shall take all necessary steps to prevent any structures from becoming buoyant. Damage to any structures due to floating or flooding shall be repaired or replaced at the Contractor's expense.

1.11 TIME OF OBSERVATION AND TESTS

- A. Samples and test specimens required under these Contract Documents shall be furnished and prepared for testing in ample time for the completion of the necessary tests and analyses before said articles or materials are to be used. The Contractor shall furnish and prepare all required test specimens within the scope of the Contract. Except as otherwise provided in the Contract Documents, the performance and cost of the required tests will be the responsibility of the Fayetteville Public Works Commission. However, the costs of any test which shows unsatisfactory results shall be borne by the Contractor. Whenever the Contractor is ready to backfill, bury, cast in concrete, or otherwise cover any Work under the Contract, the Fayetteville Public Works Commission shall be notified not less than twenty-four hours in advance to request inspection before beginning any such Work of covering. Failure of the Contractor to notify the Fayetteville Public Works Commission a minimum of twenty-four hours in advance of any such inspections shall be cause for the Fayetteville Public Works Commission to order a delay in the Contractor's schedule to allow time for inspections. Any remedial or corrective Work required, and all costs of such delays, including its effect upon other portions of the Work, shall be borne by the Contractor.

DIVISION I
01700 – PROJECT CLOSEOUT

1.01 FINAL CLEANUP

- A.** The Contractor shall promptly remove from the vicinity of the completed Work, all rubbish, unused materials, concrete forms, construction equipment, temporary structures and facilities, construction signs, tools, scaffolding, materials, supplies and equipment which may have been used in the performance of the work. The Contractor shall broom clean paved surfaces and rake clean other surfaces of grounds. Final acceptance of the Work by the Fayetteville Public Works Commission will be withheld until the Contractor has satisfactorily complied with the foregoing requirements for final cleanup of the project site.
- B.** The Contractor shall thoroughly clean all materials, equipment and structures; all marred surfaces shall be touched up to match adjacent surfaces.
- C.** The Contractor shall remove spatter, grease, stains, fingerprints, dirt, dust, labels, tags, packing materials and other foreign items or substances from interior and exterior surfaces, equipment, signs and lettering.
- D.** The Contractor shall remove paint, clean and restore all equipment and material nameplates, labels and other identification markings.
- E.** The Contractor shall maintain cleaning until project is accepted by the Fayetteville Public Works Commission.
- F.** The Contractor shall:
 - 1. Use only cleaning materials recommended by manufacturer of surface to be cleaned.
 - 2. Use each type of cleaning material on only those surfaces recommended by the cleaning material manufacturer.
 - 3. Use only materials which will not create hazards to health or property.

1.02 CLOSEOUT TIMETABLE

- A.** The Contractor shall establish dates for testing, acceptance periods, and on-site instructional periods (as required under this Contract). The dates shall be established a minimum of seven (7) calendar days prior to beginning any of the foregoing items, to allow the Fayetteville Public Works Commission sufficient time to schedule attendance at the activities.

1.03 FINAL SUBMITTALS

- A.** Before the final acceptance of the project, the Contractor shall submit to the Fayetteville Public Works Commission certain records, certifications, etc., which are specified elsewhere in these Contract Documents. Missing, incomplete or unacceptable items, as determined by the Fayetteville Public Works Commission, shall constitute grounds for withholding final payment to the Contractor. A partial list of such items appears below, but it shall be the Contractor's responsibility to submit any other items which are required in these Contract Documents:
 - 1. Written Test results of project components.
 - 2. Written guarantees, where required.
 - 3. Certificates of inspection and acceptance by local governing agencies having jurisdiction.

4. Releases from all parties who are entitled to claims against the subject project, property, or improvement pursuant to the provisions of law.

1.04 PUNCH LISTS

- A. The Fayetteville Public Works Commission will make its final inspection whenever the Contractor has notified the Fayetteville Public Works Commission that the work is ready for the inspection. Any work not found acceptable and requiring cleaning, repair and/or replacement will be noted on the punch list. Work that has been inspected and accepted by the Fayetteville Public Works Commission shall be maintained by the Contractor, until final acceptance of the entire project.
- B. Whenever the Contractor has completed the items on the punch list, the Contractor shall notify the Fayetteville Public Works Commission that it is ready for final inspection. This procedure will continue until the entire project is accepted by the Fayetteville Public Works Commission. The final payment will not be processed until the entire project has been accepted by the Fayetteville Public Works Commission and all of the requirements in these Contract Documents have been satisfied.

1.05 TOUCH-UP AND REPAIR

- A. The Contractor shall repair any and all damage to existing facilities and surfaces. If in the opinion of the Fayetteville Public Works Commission the repair work is not satisfactory, the Contractor shall make repairs until the Fayetteville Public Works Commission accepts it.

1.06 MAINTENANCE AND GUARANTEE

- A. The Contractor shall comply with all maintenance and guarantee requirements of these Contract Documents.
- B. Replacement of earth fill, backfill, or asphalt where it has settled below the required finish elevations, shall be considered as a part of such required repair work, and any repair or resurfacing constructed by the Contractor which becomes necessary by reason of such settlement shall likewise be considered as a part of such required repair work unless the Contractor obtained a statement in writing from the affected private owner or public agency releasing the Fayetteville Public Works Commission from further responsibility in connection with such repair or resurfacing.

*** END OF SECTION ***

SECTION D – TECHNICAL SPECIFICATIONS

**DIVISION 2
SITE WORK**

02750 WASTEWATER FLOW CONTROL (BYPASS PUMPING)

GENERAL

The intent and purpose of these specifications is to provide wastewater flow control, i.e., bypass pumping, of the sanitary sewer flows during the Contractor's operations. The Contractor shall furnish all labor, materials, accessories, equipment and tools for performing all operations required to bypass pump sewage around a manhole or sewer section in which work is to be performed.

The Contractor shall provide all pumps, piping, and other equipment to accomplish this task; perform all construction; obtain all permits; pay all costs; and perform complete restoration of all existing facilities to equal or better condition to the satisfaction of the Fayetteville Public Works Commission. The Contractor shall be responsible for the design, installation, operation, and maintenance of the temporary bypass pumping system. The Contractor shall provide sufficient documentation to the Fayetteville Public Works Commission to demonstrate that he, or his designated subcontractor, have the experience in the design, installation, and maintenance of temporary bypass pumping systems.

RELATED SECTIONS

- A. Section 02305 – Pipe Bursting
- B. Section 02500 – Traffic Control
- C. Section 02730 – Sanitary Sewer System
- D. Section 02760 – Television Inspection
- E. Section 02766 – Sewer Line Cleaning
- F. Section 02780 – Cured-in-Place Lining

REQUIREMENTS

The Contractor shall be responsible for all aspects of the bypass operation, including but not limited to: providing access to install, move, and maintain the pumps in the proper position, traffic control, installation and removal of bypass equipment, pump monitoring, testing of the bypass system, re-fueling, maintenance, notification of property owners (should access to private property be necessary), wastewater and fuel spill containment, and removal and replacement of manhole cones (if necessary). The bypass system (pumps and piping) shall be monitored by Contractor personnel at all times, when the bypass operation is in effect.

The Contractor shall have all materials and equipment on site to immediately respond to any emergencies or other event that could impact the bypass system (i.e., leak in the discharge piping, pump failure, flooding, etc.). The Contractor shall have sufficient support staff and equipment to mobilize to repair and/or service any equipment within one (1) hour of notification, 24 hours a day, seven (7) days a week. In the event of an emergency, the Contractor shall provide an immediate response and fully cooperate with the Fayetteville Public Works Commission.

The Contractor shall install the bypass pumps, equipment, and discharge lines to minimize impacts to the property owners, residents, and environment. The Contractor shall be responsible for determining the best

location for the bypass equipment, to include, but not limited to, the need for any special provisions to ensure access for the customers, preventing the pumps and manholes from flooding, etc. Such special provisions include, but are not limited to: installation of ramps, excavation and burial of the bypass lines, temporary fencing, sandbagging, construction of berms, raising the pumps, etc. The Contractor bears all responsibility for the maintenance and restoration of any trenches, ramps, access, etc. necessary for the temporary bypass pumping operation.

The Contractor shall take appropriate steps to ensure that all pumps, piping and hoses that carry raw sewage are protected from traffic. The Contractor shall identify the proposed methods to protect the temporary bypass pumping system from traffic as part of the detailed temporary bypass pumping plan. Traffic control shall be performed in accordance with these Contract Documents.

The bypass pumping system shall be monitored by Contractor personnel at all times (24 hours a day, 7 days a week), when the bypass operation is in effect. The Contractor's personnel shall be on-site at all times (24 hours a day, 7 days a week), and stationed at the primary bypass pumps. Depending on the location and system set-up, it may be necessary for the Contractor to station personnel at each of the various bypass pump locations. Unless otherwise approved by the Fayetteville Public Works Commission, one (1) person cannot monitor multiple bypass pump locations. All bypass pumps, regardless of their location (primary or on secondary lines), shall be equipped with an automatic dialer (or other similar device). The Contractor personnel shall immediately respond to any issue regarding the temporary bypass pumping system. All temporary bypass piping shall be periodically monitored (patrolled from pumps to discharge), but no less frequently than once every 12 hours. The bypass pumping equipment shall be automated and capable of functioning without the assistance of an operator.

SUBMITTALS

All submittals shall be provided in accordance with these Contract Documents, and the requirements outlined herein. The Contractor shall submit a detailed bypass pumping plan to the Fayetteville Public Works Commission for approval, prior to initiating the bypass operation. The Contractor shall submit this information far enough in advance to allow sufficient time to complete the necessary coordination, including but not limited to obtaining permits (i.e., encroachments), getting permission from property owners to cross and/or utilize their property, and gaining any necessary regulatory approvals. Failure to submit a complete and comprehensive bypass pumping plan in a timely manner shall not be cause for any extension of the Contract Time.

The detailed temporary bypass pumping plan shall include the following information:

- Method of monitoring the pumps to ensure proper operation, to include method of notifying personnel (Fayetteville Public Works Commission and Contractor) in the event of an emergency, activation of back-up pumps, etc.
- Method of monitoring upstream system levels to ensure surcharging does not result in back-ups into buildings, overflows, etc.
- The amount, if any, of any required surcharging.
- Method to initiate back-up pumps.
- Map showing general location of the pumps and bypass lines. This shall include means to maintain access to driveways, etc.
- Measures to secure the bypass system (lines, pumps, etc.) from traffic, vandalism, high stream flows, etc.

- Method of plugging (and securing the plug(s)) and type of plugs.
- Size and location of manholes or other access points for suction and discharge piping.
- Size of pipeline(s) or conveyance system(s) to be bypassed.
- Number, size, material, location, and method of installation of suction piping.
- Number, size, material, location, and method of installation of discharge piping.
- Bypass pump sizes, capacities, and number of each size to be provided on-site, including all primary, secondary, and spare pumping units.
- Calculations of static lift, friction losses, minimum inlet submergence, and flow velocity (pump curves showing pump operating range shall be submitted). Calculations shall be signed and sealed by a licensed Professional Engineer registered in the State of North Carolina. Calculations shall be provided for both the peak flow rate and a normal daily rate (see PUMPING AND BYPASSING section for sizing requirements).
- Measures to protect discharge manhole(s) or structure(s) from erosion and damage due to the bypass operation.
- Erosion control measures.
- Emergency contact information for the personnel responsible for the pump operation.
- Emergency contact information for Contractor personnel to respond in the event of an emergency.
- List of available resources (equipment, materials, personnel) and contact information for emergency response.
- Method to contain potential releases of sewer flow from air release valves.
- Contingency plan for responding to potential sewer spills caused by weather, vandalism, acts of God, etc. The plan shall include communication protocols, available resources, and the steps to be taken in the event of an emergency.

No bypass operations shall proceed until all bypass submittals have been reviewed and approved by the Fayetteville Public Works Commission.

COORDINATION

The Contractor shall fully coordinate their temporary bypass pumping operations with the Fayetteville Public Works Commission. It is the Contractor's responsibility to fully determine the scope and location of the temporary bypass pumping system. As outlined in these Contract Documents, the Fayetteville Public Works Commission may provide assistance with the building and maintenance of access roads, clearing of easements, etc. All coordination (to include location of the pumps and discharge lines) shall be fully discussed and agreed to prior to commencement of bypass operations.

The Contractor shall schedule a coordination meeting with the Fayetteville Public Works Commission and other personnel (Contractor, bypass sub-contractor, etc.) a minimum of three (3) business days prior to starting the temporary bypass pumping system. The purpose of this coordination meeting is to ensure that the Contractor and their sub-contractors have a good understanding of the requirements and expectations of operating the temporary bypass pumping system, discuss contingency plans (to include protocols for emergency contacts), identify location(s) of pumps, verify necessary materials (repair sleeves, containment devices, etc.) are on-site and available, and any other items necessary to ensure that the Fayetteville Public Works Commission has confidence that the appropriate personnel can operate and maintain the temporary bypass pumping system. Should, for any reason, the Fayetteville Public Works Commission deem that the Contractor and/or their sub-contractor is not prepared to operate and maintain the temporary bypass pumping system, the temporary bypass pumping system shall not be started. The Contractor shall take all necessary steps to address any concerns to the satisfaction of the Fayetteville Public Works Commission. Upon

completion of those actions, another coordination meeting shall be held, in order for the Fayetteville Public Works Commission to confirm that the Contractor and their sub-contractor is prepared to operate and maintain the temporary bypass pumping system. This process will be repeated until the Fayetteville Public Works Commission is satisfied that the Contractor and their sub-contractor are prepared to operate and maintain the temporary bypass pumping system. No additional contract time will be granted for this delay.

The temporary bypass pumping system shall run for a minimum of 24 hours, or longer as deemed by the Fayetteville Public Works Commission, prior to any activity occurring (cleaning, closed circuit television {CCTV}, etc.) within the main(s) being bypassed.

FLOW CONTROL PRECAUTIONS

Where the raw sewage flow will be blocked during the Work as a result of the temporary bypass pumping operation, the Contractor shall take all necessary precautions to protect the public health. No septic conditions shall be allowed due to Contractor's operations. The sewer system (mains, manholes, laterals, etc.) shall also be protected from damage. The following occurrences shall not be allowed:

1. No sewage shall be allowed to back up into any homes or buildings.
2. No sewage shall overflow any manholes, cleanouts or any other access to the sewers.
3. Users upstream of the project area shall be able to use all their water and sewer utilities without interruption or limitations.

If any of the above occur or are expected to occur, the Contractor shall take immediate action to alleviate one or all of the conditions. Additionally, the Contractor is required to observe the conditions upstream of the plug and be prepared to immediately increase bypass pumping or release the flows, as required. Any damage claims resulting from the Contractor's failure to properly maintain sewer flows shall be the Contractor's responsibility.

All sump pumps, bypass pumps, trash pumps or any other type pump which pulls sewage or any type of material out of the sanitary sewer system shall discharge into another sanitary sewer manhole, or appropriate vehicle or container acceptable to the Fayetteville Public Works Commission. Under no circumstances shall untreated sanitary sewer be discharged, stored or deposited on the ground, swale, road or open environment. The Contractor shall not allow any flow of sewage onto private property, streets, or into creeks and drainage systems. Damage due to negligence of the Contractor, including, but not limited to, flooded dwellings, damaged property, damaged driveways, etc., shall be corrected immediately by the Contractor at no additional cost to the Fayetteville Public Works Commission.

PLUGGING AND BLOCKING

In some applications, the wastewater flow may be plugged and contained within the capacity of the collection system. This shall only be done when it has been determined the system can accommodate the surcharging without any adverse impact. The Contractor has the sole responsibility for determining whether the system can accommodate surcharging. If this option is selected, the Contractor shall be responsible for continuously monitoring the system to ensure no sewer spills or overflows occur.

A sewer line plug shall be inserted into the line at a manhole upstream from the section being surveyed or repaired. The plug shall be so designed that all or any portion of the operation flows can be released. The Contractor shall secure the plug, to prevent it from being dislodged and moving downstream. Flows shall be bypassed for the initial CCTV inspection and shall be bypassed throughout the duration of the work, to

include the final CCTV inspection. Flows shall be bypassed in accordance with the approved temporary bypass pumping plan. Upon acceptance of the work by the Fayetteville Public Works Commission, the temporary bypass pumping system shall be removed and flows restored.

PUMPING AND BYPASSING

The Contractor, when and where required, shall divert sewer flows for the sewer pipe rehabilitation process, cleaning, television inspection, pipe repairs, manhole replacement and/or rehabilitation, obstruction removals, or other related as required to complete the Work. The pumps and bypass lines shall be of adequate capacity and size to handle and prevent backup or overflow for all flows.

The temporary bypass pumping system shall be designed to maintain the flows necessary to meet the requirements of each particular location. The temporary sewer bypass system shall have the capacity to handle the flows outlined in these Contract Documents. The temporary sewer bypass system shall be sized to handle 2.5 times the average daily flow rate, or the specified peak flow – whichever is greater.

The Contractor shall be responsible for furnishing the necessary labor and supervision to set up, operate, and maintain the temporary bypass pumping system. A “set up” consists of the necessary pumps, conduits and other equipment to divert the flow of sewage, from the start to finish of work performed. Each “set-up”, regardless of location, shall have Contractor personnel on-site at all times (24 hours a day, 7 days a week) and stationed at the pumps, unless otherwise approved by the Fayetteville Public Works Commission. The temporary bypass pumping system shall include:

- A minimum of one (1) redundant pump so that the temporary bypass pumping system is capable of transmitting the peak flow with the largest duty pump out of service.
- Pumps shall be provided with a means of automatic control via level sensing. Systems requiring manual starting and/or stopping shall not be allowed.
- All equipment (primary and secondary pumps) shall be equipped in a manner to keep noise to a maximum of 65 dBA at 30 feet.
- An automatic dialer (or similar) to immediately notify (in a sequential operation) Contractor and Fayetteville Public Works Commission personnel in the event of equipment failure. The automatic dialer shall be set to issue notifications prior to flow level reaching critical elevations and having a spill occur. All bypass pumps (regardless of location) shall be equipped with an automatic dialer (or similar).

The temporary bypass pumping system shall be provided in such a way as to maintain access for businesses and residences. The Contractor shall be responsible for determining the best location for the bypass equipment, and the need for any special provisions to ensure access for the residents and businesses. Such special provisions include, but are not limited to: installation of ramps, excavation and burial of the bypass lines, etc. The Contractor shall use bridges over the bypass lines, temporary lines under driveways, alternate routes, or other means to accomplish this item. The bypass plan submittal shall indicate the means of maintaining access. The Contractor bears all responsibility for the maintenance of any trenches, ramps, etc. necessary for the bypass operation.

Pumps, equipment, and bypass lines shall be continuously (24 hours a day, 7 days a week) monitored by on site Contractor personnel capable of starting, stopping, refueling and maintaining these pumps during the Work. The temporary bypass pumping system shall be provided with an automatic dialer (or other similar device) that will immediately notify (in a sequential operation) the Contractor and the Fayetteville Public Works Commission in the event of equipment failure. All bypass pumps (regardless of location) shall be

equipped with an automatic dialer. This automatic dialer (or similar) shall be set to issue notifications prior to flow levels reaching critical elevations and having a spill occur.

The automatic dialer shall be set to issue notifications through a sequential operation. Automatic dialers that are not set up for sequential notifications shall not be acceptable. The Contractor's personnel shall be the first to receive any notifications from the automatic dialer. The automatic dialer shall only notify the PWC personnel after all Contractor notifications have been ignored and/or not responded to. The Contractor shall properly adjust the level at which the automatic dialer initiates notification to provide adequate time for the sequential notification to occur. If the PWC personnel are notified by the automatic dialer, the PWC personnel shall assume that a spill is occurring or is imminent, and respond accordingly. The Contractor shall be responsible for all costs for the PWC to mobilize and respond to the notification, regardless if a spill occurred or not.

In some applications, it may be necessary to surcharge the system in order to ensure proper pump operation. This shall only be done when it has been determined the system can accommodate the surcharging without any adverse impact. The Contractor has the sole responsibility for determining whether the system can accommodate surcharging. In the event surcharging is necessary, the Contractor shall be responsible for continuously monitoring the system to ensure no sewer spills occur.

All bypass piping shall successfully pass a hydrostatic test prior to bypassing the sewer flows. The hydrostatic test pressure shall be no less than the expected discharge pressures, and shall be held for a minimum of one (1) hour. All testing shall be observed by the Fayetteville Public Works Commission. Testing shall be coordinated with the Fayetteville Public Works Commission a minimum of 24 hours in advance.

SPILL RESPONSE

The Contractor shall not discharge or pump any sewage, solids, or debris on the ground, streets, storm water system, ditches, or streams. Any sewage spills shall be immediately reported to the Fayetteville Public Works Commission Water Resources Construction Department, (910) 223-4716. After normal business hours, the Contractor shall contact the Fayetteville Public Works Commission Dispatch Center, (910) 678-7400 or (910) 323-0178. The Contractor shall take complete responsibility for all costs related to the clean-up of the spill, including any fines issued by the North Carolina Department of Environmental Quality (NC DEQ).

In the event that raw sewage (in any quantity) is spilled, discharged, leaked or otherwise deposited in the open environment, due to the Contractor's work, the Contractor is responsible for any cleanup of solids and disinfection of the area affected. This work will be performed at the Contractor's expense with no additional cost to the Fayetteville Public Works Commission. The Contractor is also responsible for complying with any and all regulatory requirements in regards to the size spill with no additional cost to the Fayetteville Public Works Commission. The Contractor shall cooperate fully with the Fayetteville Public Works Commission and the applicable State agencies in responding to and cleaning up the spill. Any work completed by the Fayetteville Public Works Commission in responding to a spill caused by the Contractor's operations shall be billed to the Contractor.

Where sewage has backed up into a property due to any aspect of the Contractor's operation, the Contractor shall immediately notify the Fayetteville Public Works Commission, inspect the property with the Fayetteville Public Works Commission and agree on remedial measures. The Contractor shall be responsible for all cleaning, repair and/or replacement of damaged property, temporary relocation of all occupants of the affected properties, if required, all to the satisfaction of the property owner. These actions shall be undertaken

Revised September 2019

immediately upon learning of the backup. Cleaning shall be performed by firms specializing in this type of work. All costs associated with the cleaning, repair, replacement of damages, occupant accommodations, insurance and spill remediation shall be borne by the Contractor. All remediation measures required as part of a spill response are part of acceptance of the project, and final payment shall not be made until such time all required measures are addressed and approved by the appropriate regulatory agency.

*** END OF SECTION ***

APPENDICES

CONSULTANTS:

This drawing and the design shown are the property of Fleming & Associates, P.A. The reproduction, copying or other use of this drawing without their written consent is prohibited and any infringement will be subject to legal action.
© Fleming 2026

PROJECT NAME:

**CARGILL LIFT STATION
STRUCTURAL
REPAIR**



1798 RIVER ROAD, FAYETTEVILLE, NC 28312

SEALED



01/26/2026

DESIGNED BY: JK

DRAWN BY: DW/JK

CHECKED BY: JK

REVISIONS:

NO.	DESCRIPTION	DATE

SHEET TITLE:

PLANS, DETAILS, & NOTES

ISSUE DATE: 01/26/2026

PROJECT NO: 25-31

SHEET NUMBER: S1

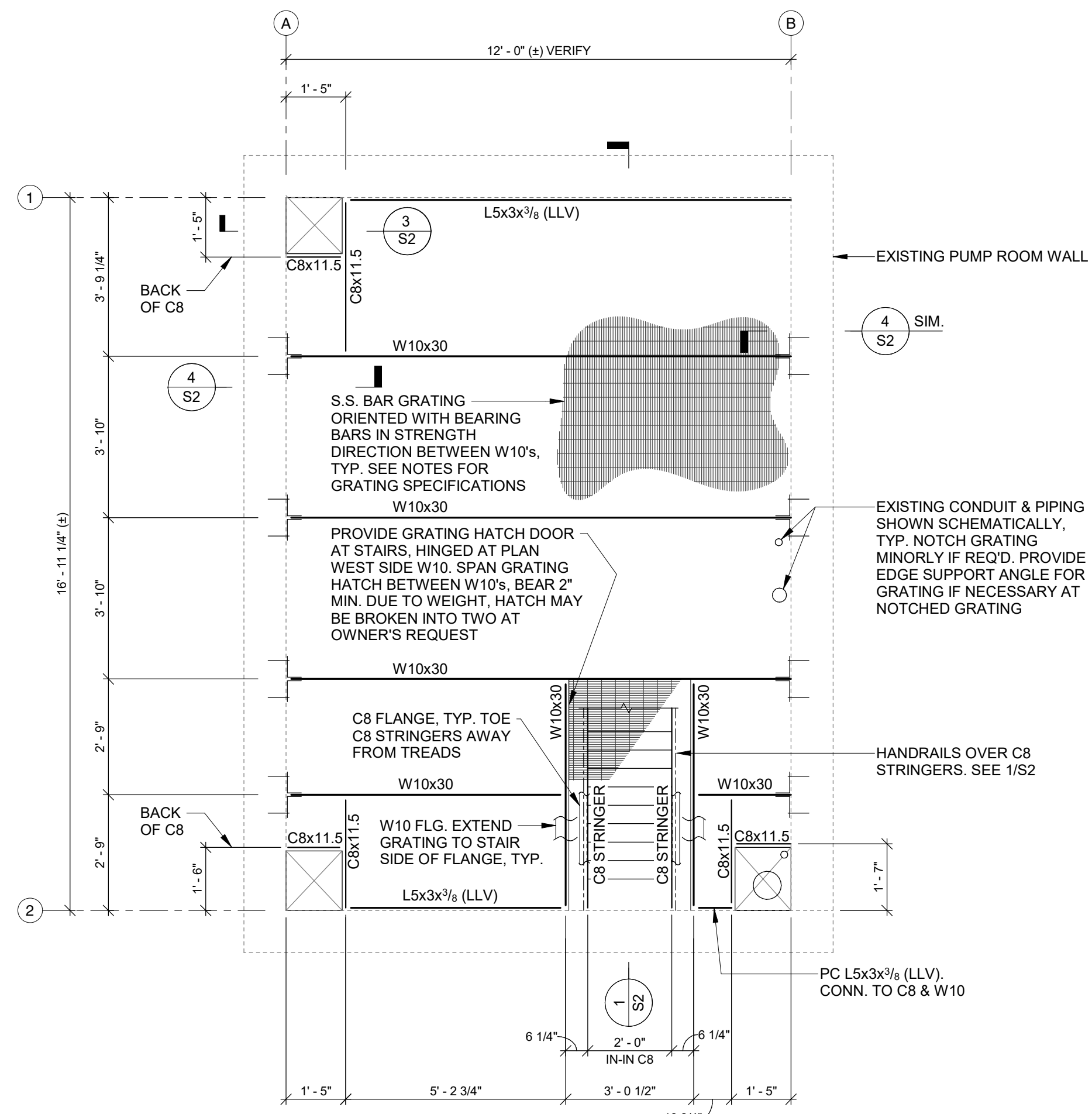

TOP OF WET WELL 1
3/8" = 1'-0" S1

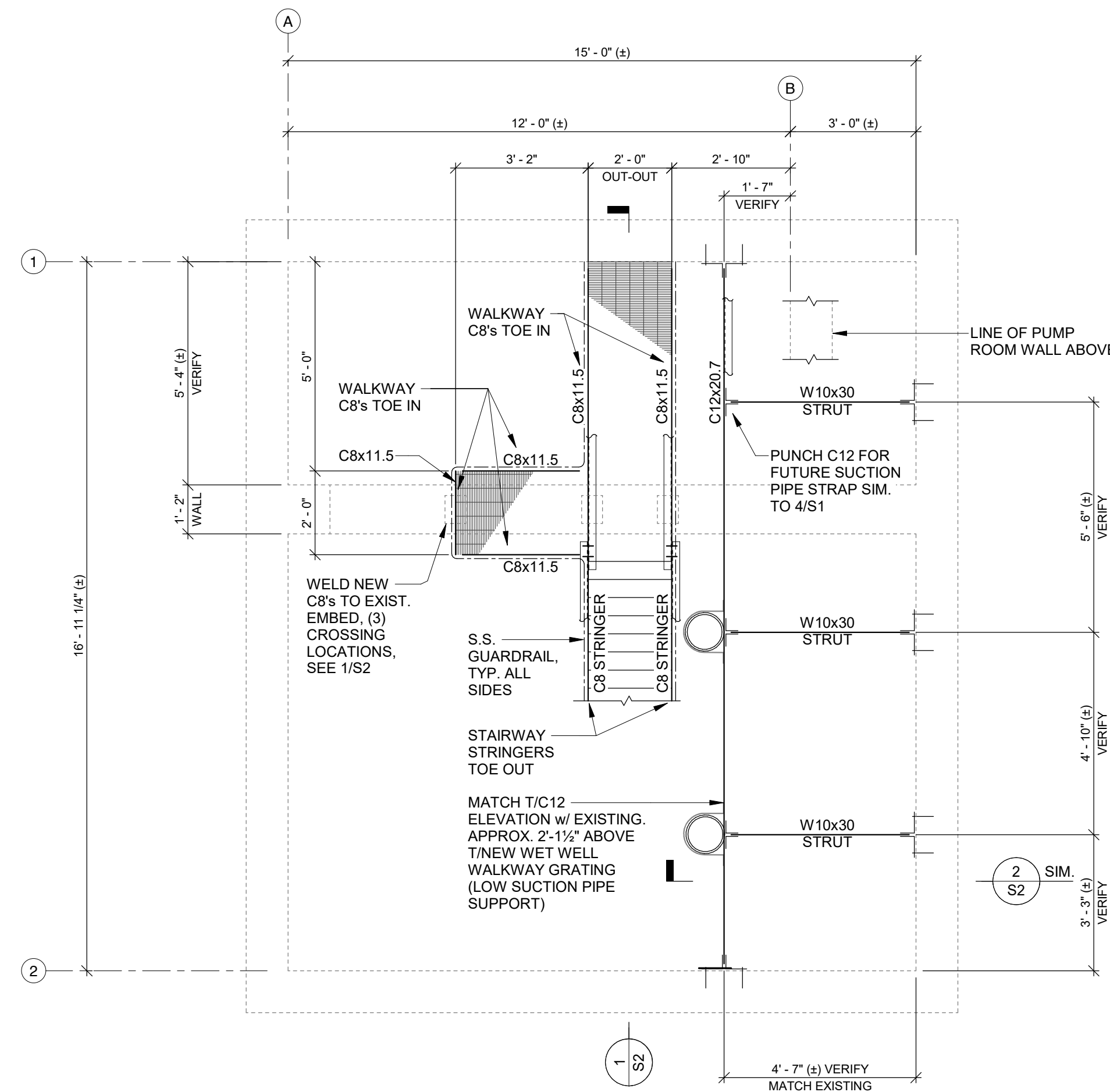

WET WELL AT CATWALK 2
3/8" = 1'-0" S1

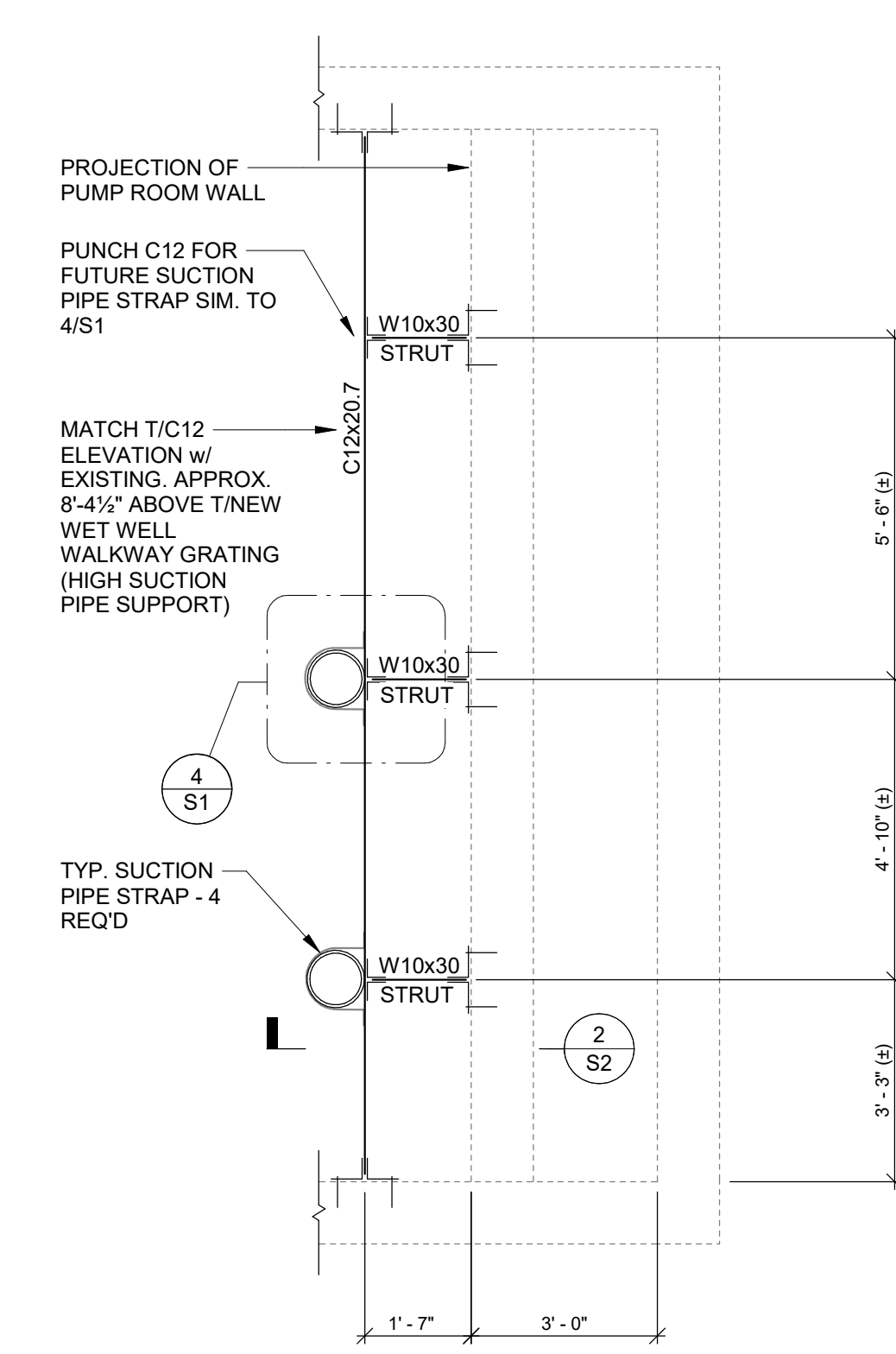

SUCTION PIPE SUPPORTS (HIGH) 3
3/8" = 1'-0" S1

GENERAL NOTES

- DESIGN LOAD DATA
LIVE LOADS:
TYPICAL ALL WALKING SURFACES..... 100psf UNIFORM, 300 lb CONCENTRATED
- MATERIALS
A. STRUCTURAL STEEL TYPE UNS S31603 (316L), F_y=25 ksi STAINLESS STEEL (HOT ROLLED) UNDER ASTM A240 (PLATES) AND ASTM A276 (CHANNELS & WIDE FLANGE)
B. BOLTS ASTM F593G-S31603 (ALLOY GROUP 2), NUTS TO BE ASTM F594 E316L-XX
C. WELD ELECTRODES Hilli Kwik Bolt III (OR EQUAL)
D. EXPANSION BOLTS Hilli HIT-RE 500 V3 (OR EQUAL) FOR ANCHORAGE TO CONCRETE
E. EPOXY ANCHORING SYSTEM TYPE 316L SS 195G4 WITH 1"x1/2" BEARING BARS
F. BAR GRATING
- SUPERSTRUCTURE
A. ALL WELDERS, SHOP AND FIELD, WILL BE CERTIFIED FOR THE TYPE OF WORK INVOLVED. SUBMIT CERTIFICATIONS.
B. ALL SHOP DRAWINGS WILL BE CHECKED BY THE FABRICATOR BEFORE BEING SUBMITTED TO THE ARCHITECT/ENGINEER FOR REVIEW. WHEN SUBMITTING ELECTRONIC SHOP DRAWINGS, ONE (1) HARD COPY MUST BE PROVIDED TO THE STRUCTURAL ENGINEER BEFORE REVIEW CAN BEGIN.
C. STRUCTURAL STEEL CONNECTIONS WILL BE DESIGNED BY THE FABRICATOR'S NC REGISTERED ENGINEER UNLESS SPECIFICALLY DETAILED ON THE STRUCTURAL DRAWINGS. ALL CONNECTIONS ARE TO BE DESIGNED AS SIMPLE CONNECTIONS EXCEPT WHERE INDICATED OTHERWISE ON PLANS OR IN SECTIONS.
D. CONNECTIONS: SHOP - BOLTED OR WELDED FIELD - BOLTED U.N.O.
E. BOLTS WILL BE 3/4" DIAMETER UNLESS OTHERWISE NOTED. ALL BOLTS WILL BE TIGHTENED BY A FEW IMPACTS OF AN IMPACT WRENCH OR THE FULL EFFORT OF A MAN USING AN ORDINARY SPUD WRENCH WITH A MINIMUM OF 200 FOOT POUNDS OF TORQUE AND A MAXIMUM OF 250 FOOT POUNDS OF TORQUE FOR A SNUG TIGHT CONDITION.
F. U.N.O. BOLT THREADS CAN BE EITHER CUT OR ROLLED. IF THREADS ARE ROLLED, DO NOT REDUCE BOLT DIAMETER. MAKE ADJUSTMENTS ON SHOP DRAWINGS FOR INCREASED SHANK DIAMETER AT THREAD LOCATION.
G. ALL STRUCTURAL BOLTS WILL HAVE HEAVY HEX NUTS.
H. UNLESS SHOWN OTHERWISE ALL FIELD WELDS WILL BE 3/16 INCH FILLET WELDS.
I. **GENERAL CONTRACTOR TO VERIFY ALL EXISTING DIMENSIONS, ELEVATIONS, AND CONDITIONS BEFORE FABRICATING STEEL.** NOTIFY ENGINEER OF ANY SIGNIFICANT DISCREPANCIES.
J. ALL DETAILING, FABRICATING, AND ERECTION SHALL CONFORM TO THE FOLLOWING SPECIFICATIONS (LATEST EDITIONS), EXCEPT AS OTHERWISE INDICATED:
AISC 360-10 - "SPECIFICATION FOR STRUCTURAL STEEL BUILDINGS."
AISC 303-10 - "CODE FOR STANDARD PRACTICE FOR STEEL BUILDINGS AND BRIDGES."
PARAGRAPH 4.4.1 OF THE ABOVE CODE IS HEREBY MODIFIED BY DELETION OF THE FOLLOWING SENTENCES:
A) "CONFIRMATION THAT THE FABRICATOR HAS CORRECTLY INTERPRETED THE CONTRACT DOCUMENTS IN THE PREPARATION OF THOSE SUBMITTALS";
B) "CONFIRMATION THAT THE OWNER'S DESIGNATED REPRESENTATIVE FOR DESIGN HAS REVIEWED AND APPROVED THE CONNECTION DETAILS SHOWN ON THE SHOP AND ERECTION DRAWINGS AND SUBMITTED IN ACCORDANCE WITH SECTION 3.1.2, IF APPLICABLE";
AWS D1.1 - "STRUCTURAL WELDING CODE - STEEL."
K. GENERAL CONTRACTOR SHALL HAVE SOLE RESPONSIBILITY FOR SITE SAFETY. FABRICATOR AND ERECTOR SHALL REVIEW CONTRACT DOCUMENTS AND IF THE STRUCTURE, AS SHOWN ON THOSE DOCUMENTS, IS IN CONFLICT WITH THE REQUIREMENTS OF ANY ERECTION SAFETY REGULATIONS, FABRICATOR SHALL NOTIFY STRUCTURAL ENGINEER PRIOR TO COMMENCING ERECTION SHOP DRAWING PRODUCTION. FABRICATOR AND/OR ERECTOR FAIL TO NOTIFY STRUCTURAL ENGINEER, AS STATED ABOVE, THEY SHALL BECOME RESPONSIBLE FOR ALL COSTS FOR CORRECTING SUCH CONFLICTS WITH THE REQUIREMENTS OF ANY AND ALL SAFETY REGULATIONS.
L. GENERAL CONTRACTOR WILL BE RESPONSIBLE FOR PROPERLY GUYING AND BRACING THE STRUCTURE TO RESIST LIVE, DEAD, WIND, AND CONSTRUCTION LOADS DURING CONSTRUCTION. AN UNSTABLE CONDITION EXISTS UNTIL ALL THE STRUCTURAL COMPONENTS ARE IN PLACE.
M. GENERAL CONTRACTOR IS RESPONSIBLE FOR COORDINATING LOCATIONS OF BRACES, BRIDGING, AND MISCELLANEOUS FRAMING TO AVOID CONFLICT WITH DUCTS, PLUMBING, OR ANY OTHER UTILITY.

- STAIRS
A. RISER & TREAD DIMENSIONS AND STAIR ORIENTATIONS ARE TO COMPLY WITH SECTION 1011.15 "SHIPS LADDERS" OF THE 2018 NC BUILDING CODE. CONTACT ENGINEER IF DISCREPANCIES ARE ENCOUNTERED WITH THE DETAILS CONTAINED HEREIN.
B. HANDRAILS ARE TO BE DESIGNED PER THE NORTH CAROLINA STATE BUILDING CODE.
 - MISCELLANEOUS
A. THE STRUCTURAL DRAWINGS TAKE PRECEDENCE WHEN A CONFLICT OCCURS BETWEEN THE STRUCTURAL DRAWINGS AND OTHER DRAWINGS.
B. GENERAL CONTRACTOR TO VERIFY ALL EXISTING BUILDING DIMENSIONS, ELEVATIONS, AND DETAILS WITH THE FIELD CONDITIONS. NOTIFY THE ARCHITECT AND ENGINEER OF ANY SIGNIFICANT DISCREPANCIES.
C. GENERAL CONTRACTOR TO NOTIFY OUR OFFICE DURING MAJOR PHASES OF CONSTRUCTION SO OBSERVATIONS CAN BE MADE BY OUR OFFICE AS REQUIRED.
D. PATCH AND REPAIR EXISTING EMBED HOLES AS REQUIRED AFTER DEMOLITION.
 - POST-INSTALLED ANCHORS (HILLI ANCHORS)
A. ANCHOR CAPACITY USED IN DESIGN IS BASED ON THE TECHNICAL DATA PUBLISHED BY HILLI. SUBSTITUTION REQUESTS FOR ALTERNATE PRODUCTS OR DRILLING METHODS MUST BE APPROVED IN WRITING BY THE STRUCTURAL ENGINEER OF RECORD PRIOR TO USE. CONTRACTOR SHALL PROVIDE CALCULATIONS DEMONSTRATING THAT THE SUBSTITUTED PRODUCT MEETS OR EXCEEDS THE PERFORMANCE CAPACITIES OF THE SPECIFIED PRODUCT. SUBSTITUTIONS WILL BE EVALUATED BY THEIR HAVING AN ICC ESR SHOWING COMPLIANCE WITH THE RELEVANT BUILDING CODE FOR SEISMIC USES, LOAD RESISTANCE, INSTALLATION CATEGORY, AND/OR AVAILABILITY OF COMPREHENSIVE INSTALLATION INSTRUCTIONS. ADHESIVE ANCHOR EVALUATION WILL ALSO CONSIDER CREEP, IN-SERVICE TEMPERATURE, AND INSTALLATION TEMPERATURE.
B. USE OF DIAMOND CORE BIT WITH ROUGHENING TOOL FOR ANCHOR HOLES REQUIRES APPROVAL FROM ENGINEER OF RECORD PRIOR TO DRILLING. UNLESS OTHERWISE SHOWN IN THE DRAWINGS, ALL HOLES SHALL BE DRILLED PERPENDICULAR TO THE CONCRETE SURFACE.
C. INSTALL ANCHORS PER THE MANUFACTURER'S PRINTED INSTALLATION INSTRUCTIONS, AS INCLUDED IN THE ANCHOR PACKAGING.
D. THE CONTRACTOR SHALL ARRANGE FOR AN ANCHOR MANUFACTURER'S REPRESENTATIVE TO PROVIDE ONSITE INSTALLATION TRAINING FOR ALL ANCHOR PRODUCTS SPECIFIED. THE STRUCTURAL ENGINEER OF RECORD MUST RECEIVE DOCUMENTED CONFIRMATION THAT ALL PERSONNEL WHO INSTALL ANCHORS ARE TRAINED PRIOR TO THE COMMENCEMENT OF ANCHOR INSTALLATION.
E. ANCHOR CAPACITY IS DEPENDENT UPON SPACING BETWEEN ADJACENT ANCHORS AND PROXIMITY OF ANCHORS TO EDGE OF CONCRETE/MASONRY. INSTALL ANCHORS IN ACCORDANCE WITH SPACING AND EDGE CLEARANCES INDICATED ON THE DRAWINGS.
- SCOPE OF WORK**
DESIGN REPLACEMENT FOR DETERIORATED STRUCTURAL STEEL AND ALUMINUM ELEMENTS @ EXISTING WET WELL. CONTRACTOR IS TO DEMOLISH EXISTING HANDRAILS, GRATING, GRATING SUPPORTS, PIPE SUPPORTS, ETC. AND PROPERLY DISPOSE. LEAVE EXISTING PUMP EQUIPMENT, PIPING, METERING DEVICES, ETC. IN PLACE BUT TEMPORARILY DETACH AS REQ'D BY PWC. COORDINATE MINOR RELOCATIONS OR TEMPORARY DETACHMENTS WITH PWC DURING PRE-CONSTRUCTION CONFERENCE WITH PWC.

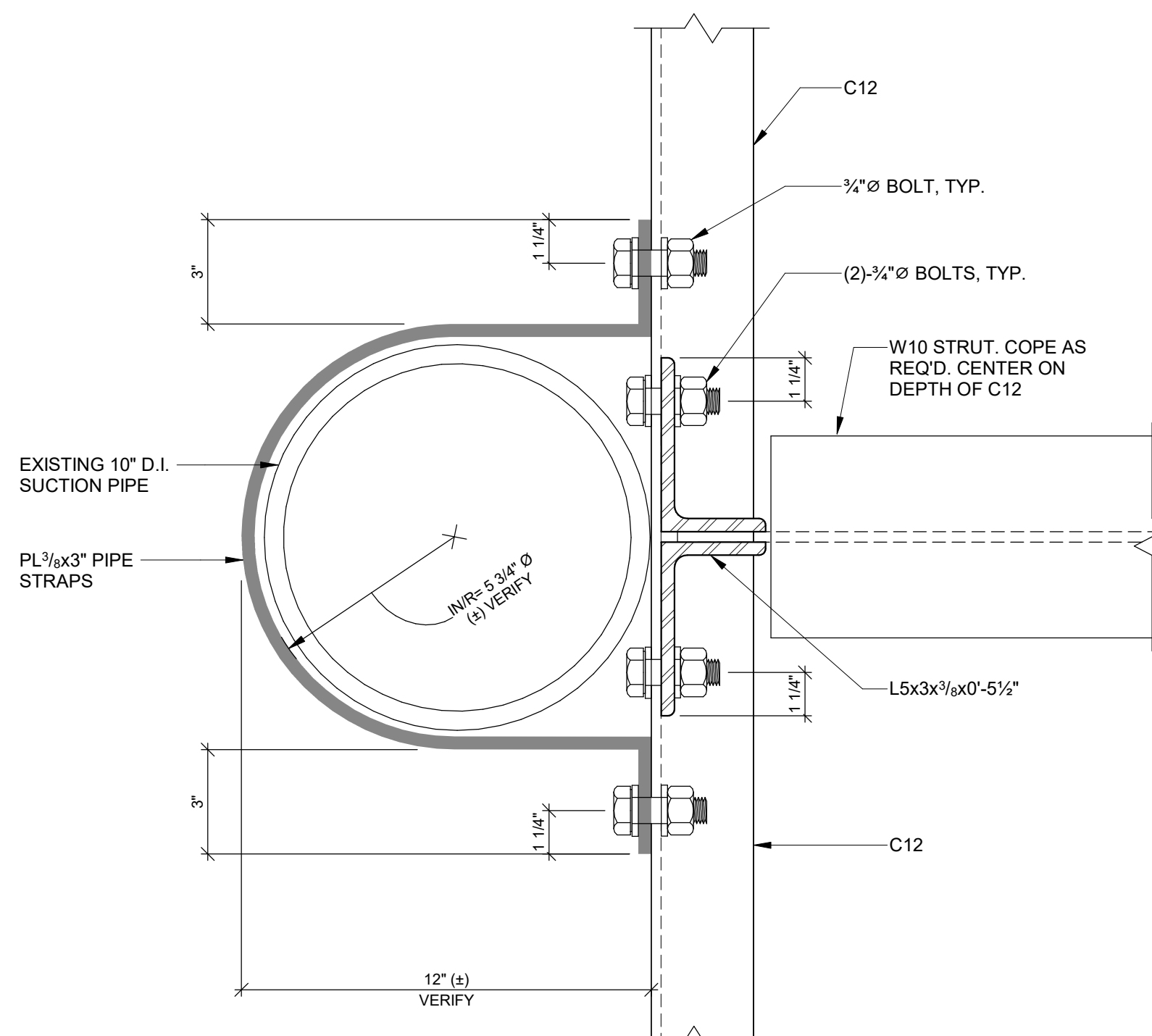

PLAN @ TYP. SUCTION PIPE STRAP 4
3" = 1'-0" S1

GENERAL NOTES

CONSULTANTS

This drawing and the design shown are the property of Fleming & Associates, P.A. The reproduction, copying or other use of this drawing without their written consent is prohibited and any infringement will be subject to legal action.
© Fleming 2026

PROJECT NAME

CARGILL LIFT STATION STRUCTURAL REPAIR



1798 RIVER ROAD, FAYETTEVILLE, NC 28312

SEA



01/26/2026

PROJECT TEAM

DESIGNED BY: JK
DRAWN BY: DW/JK
CHECKED BY: JK

REVISIONS

NO.	DESCRIPTION	DATE

SHEET TITLE

SECTIONS

ISSUE DATE SHEET NUMBER

01/26/2026 PROJECT NO. 25-31

S2

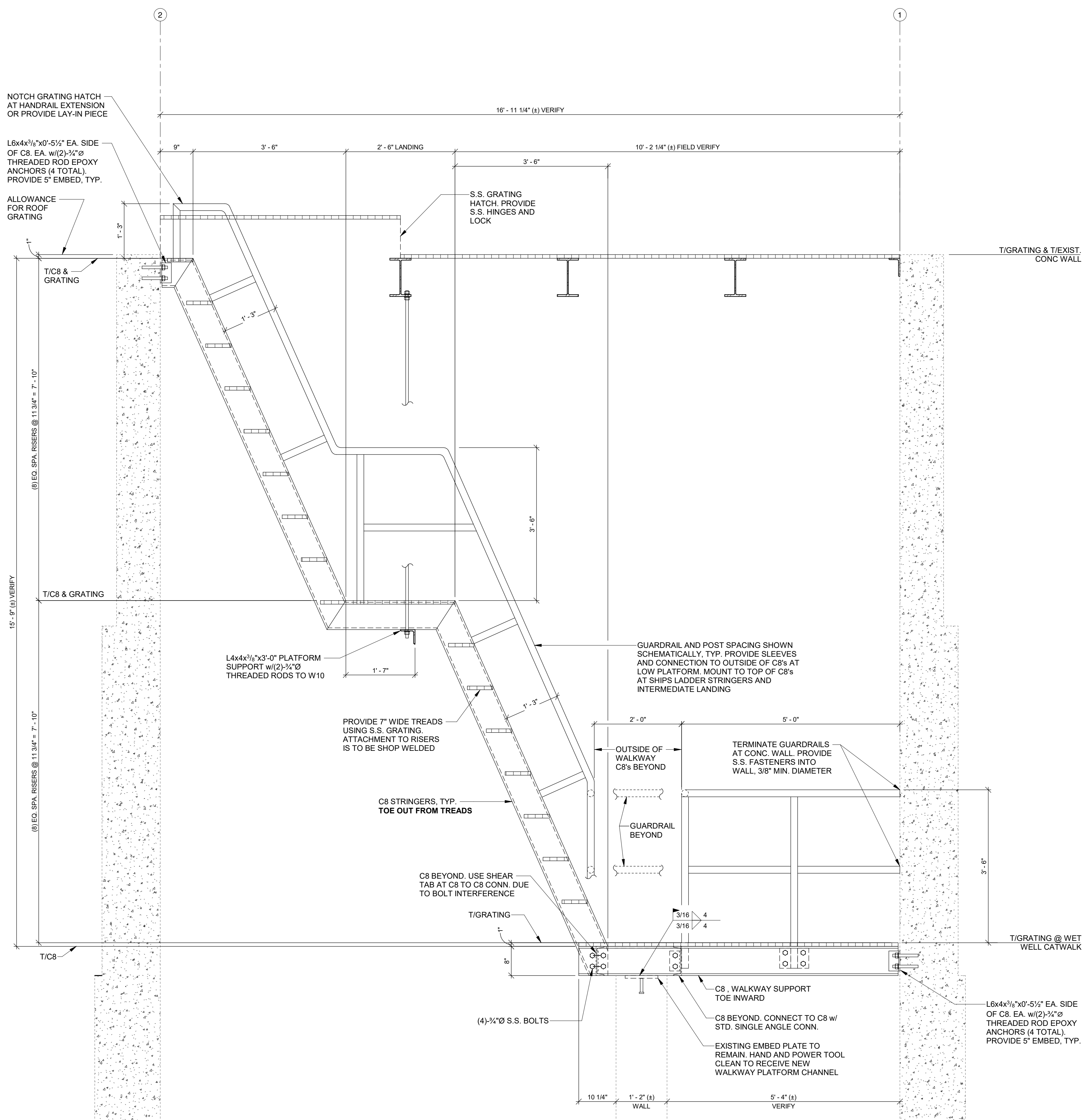

STAIR SECTION 1
3/4" = 1'-0" S2

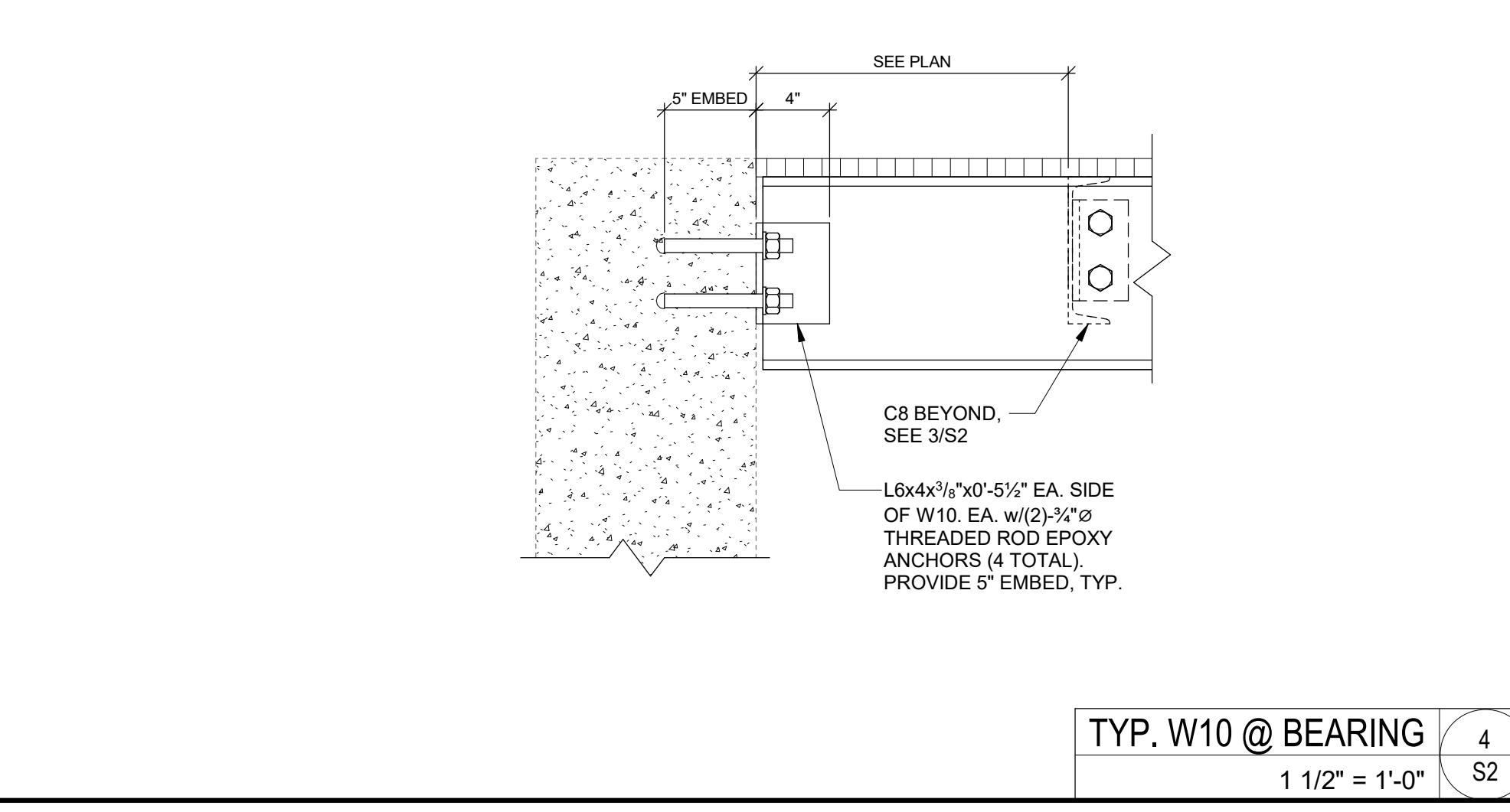
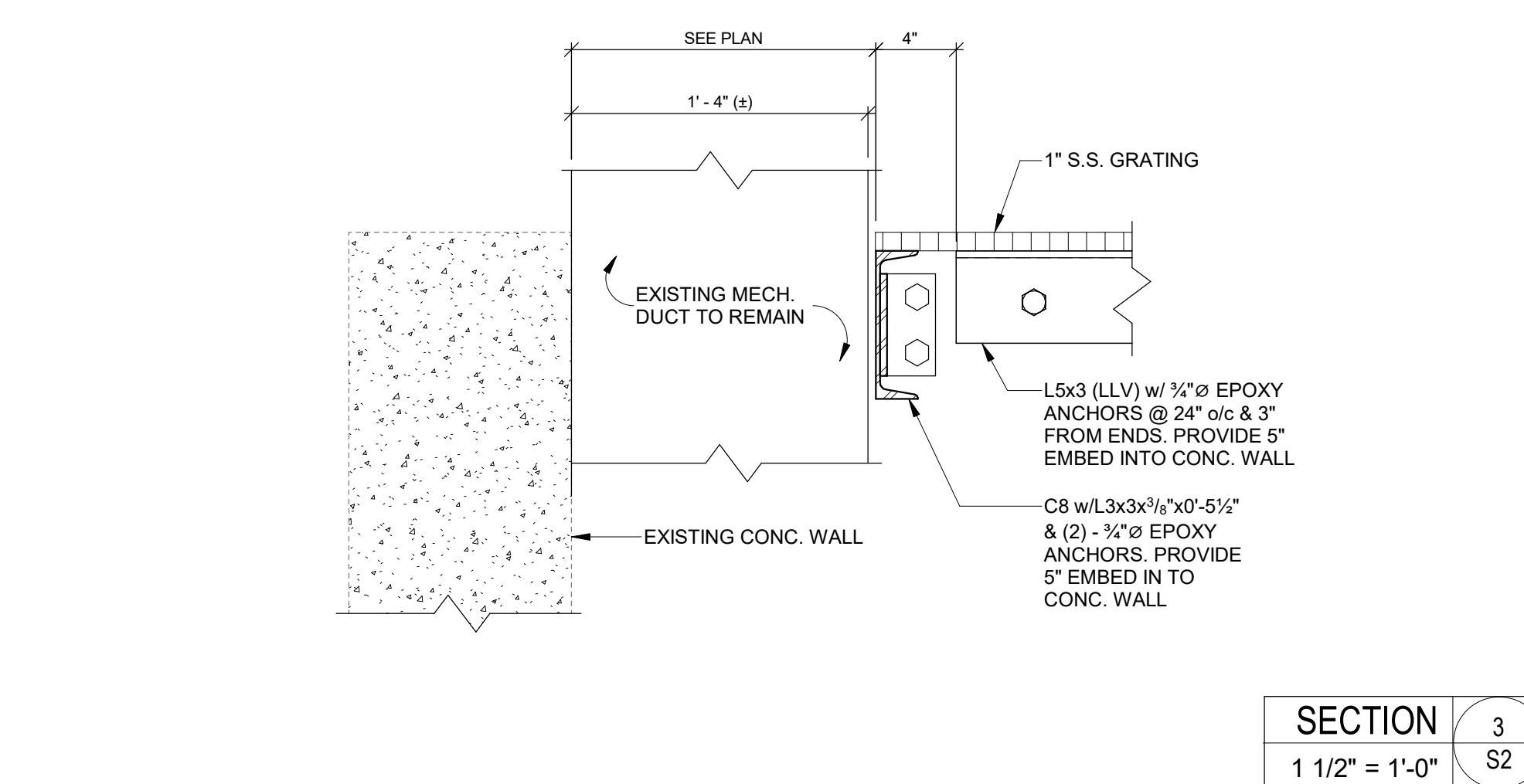
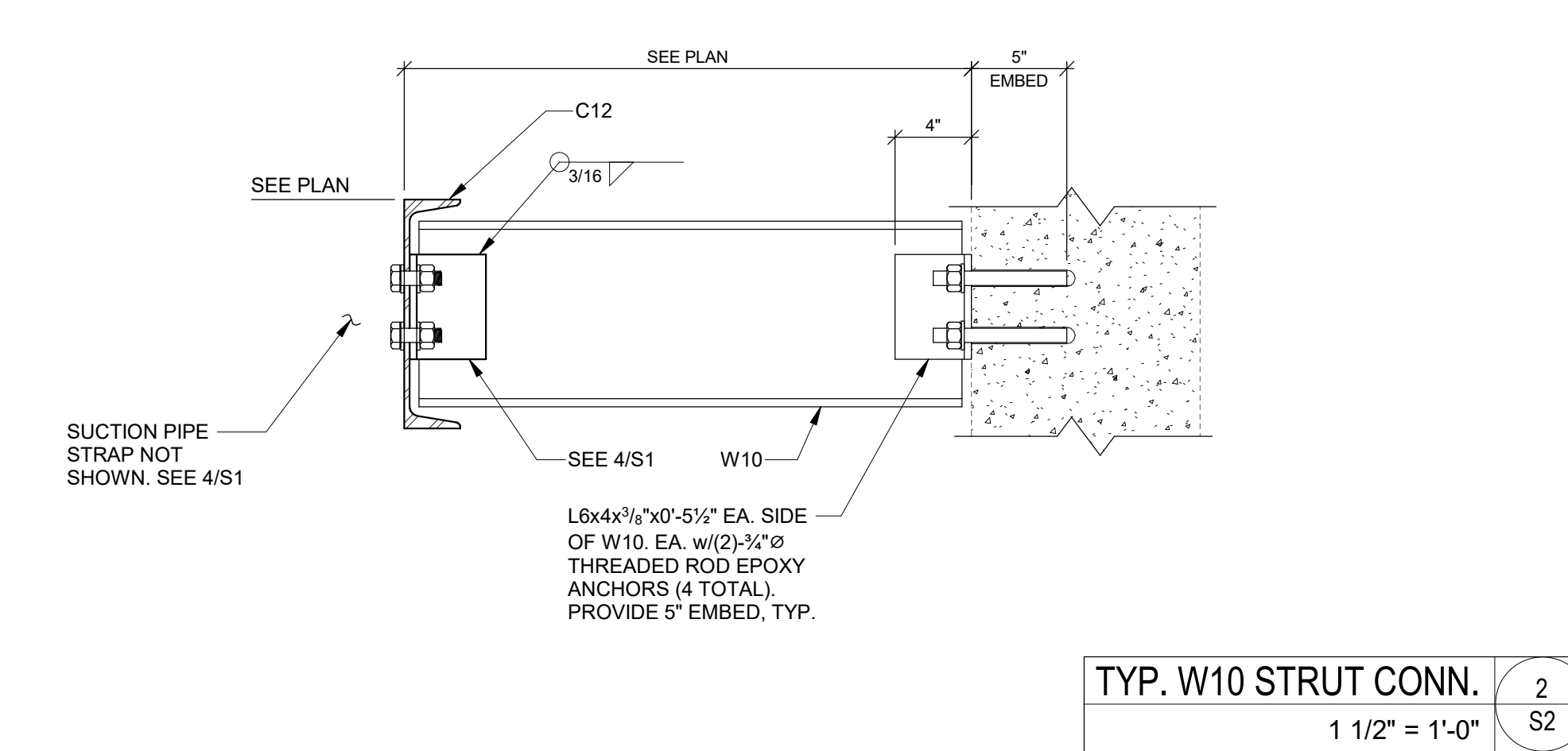

Access to Lift Station #33 Cargill



1/26/2026, 4:18:22 PM

- Street Names
- Cumberland County Parcel
- Site Address
- Septic Incidents

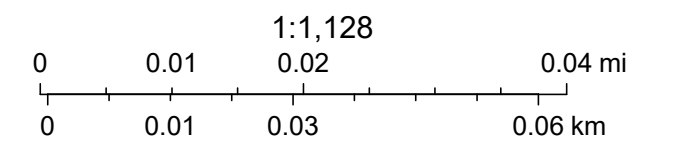

NC CGIA, Microsoft, Vantor

Access to Lift Station #33 Cargill

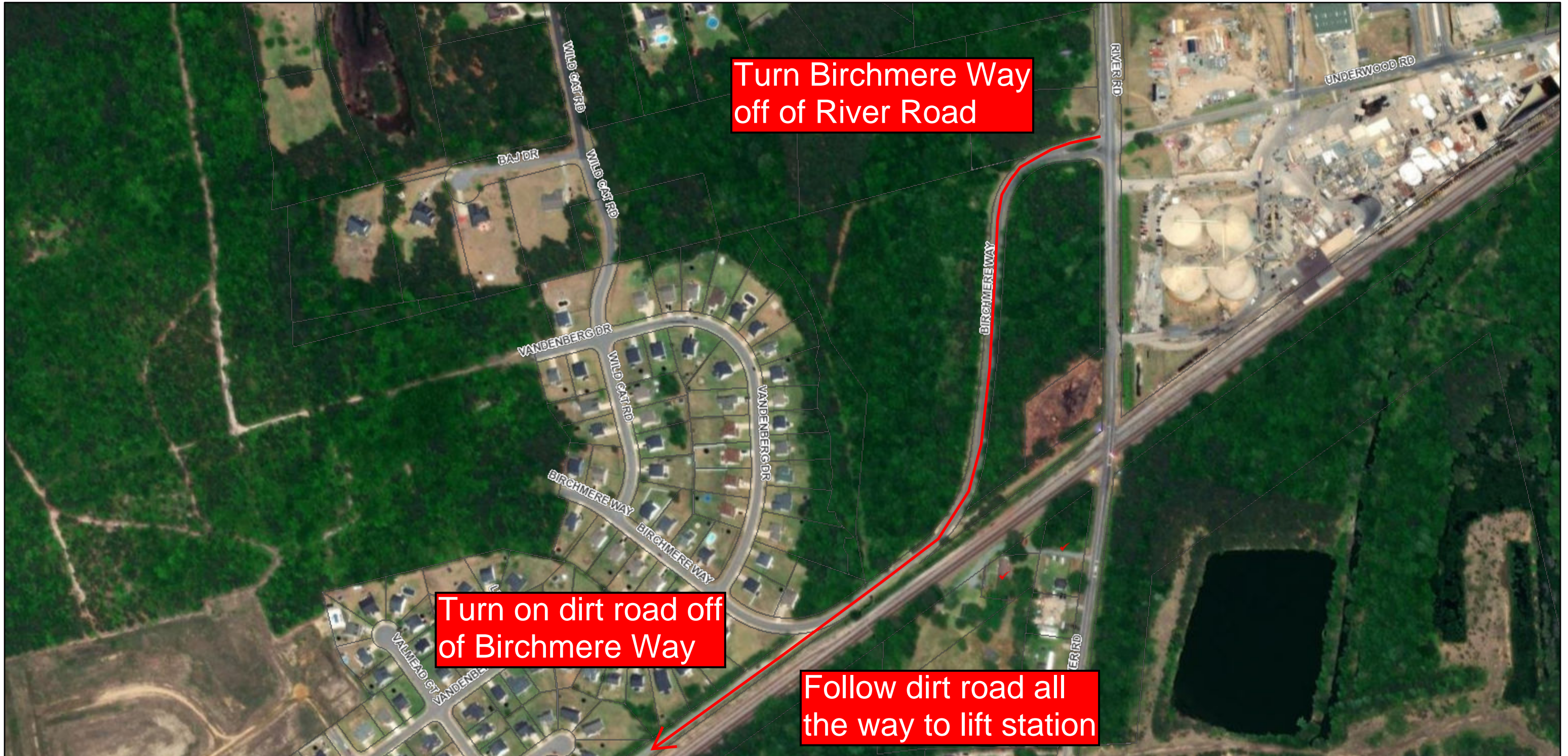

1/26/2026, 4:28:11 PM

- Street Names
- Cumberland County Parcel
- Septic Incidents

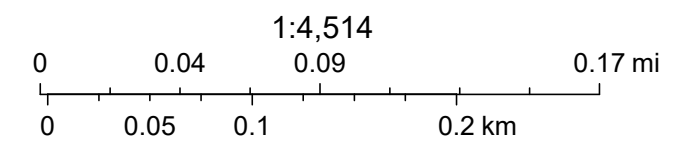

NC CGIA, Vantor